

DIGITALES ARCHIV

ZBW – Leibniz-Informationszentrum Wirtschaft
ZBW – Leibniz Information Centre for Economics

Zinko, Iryna; Kravchenko, Olha; Syvoglaz, Dmytro

Article

Designing an Internet of Things solution for monitoring vital signs

Technology audit and production reserves

Reference: Zinko, Iryna/Kravchenko, Olha et. al. (2024). Designing an Internet of Things solution for monitoring vital signs. In: Technology audit and production reserves 2 (2/76), S. 17 - 24.
<https://journals.uran.ua/tarp/article/download/300745/293825/696132>.
doi:10.15587/2706-5448.2024.300745.

This Version is available at:

<http://hdl.handle.net/11159/653932>

Kontakt/Contact

ZBW – Leibniz-Informationszentrum Wirtschaft/Leibniz Information Centre for Economics
Düsternbrooker Weg 120
24105 Kiel (Germany)
E-Mail: [rights\[at\]zbw.eu](mailto:rights[at]zbw.eu)
<https://www.zbw.eu/econis-archiv/>

Standard-Nutzungsbedingungen:

Dieses Dokument darf zu eigenen wissenschaftlichen Zwecken und zum Privatgebrauch gespeichert und kopiert werden. Sie dürfen dieses Dokument nicht für öffentliche oder kommerzielle Zwecke vervielfältigen, öffentlich ausstellen, aufführen, vertreiben oder anderweitig nutzen. Sofern für das Dokument eine Open-Content-Lizenz verwendet wurde, so gelten abweichend von diesen Nutzungsbedingungen die in der Lizenz gewährten Nutzungsrechte.



<https://zbw.eu/econis-archiv/termsfuse>

Terms of use:

This document may be saved and copied for your personal and scholarly purposes. You are not to copy it for public or commercial purposes, to exhibit the document in public, to perform, distribute or otherwise use the document in public. If the document is made available under a Creative Commons Licence you may exercise further usage rights as specified in the licence.

8. Mulesa, O., Melnyk, O., Horvat, P., Tokar, M., Peresoliak, V., Kumar, H. (2023). Modeling of Decision-Making Processes in the Service Management System. *2023 IEEE 18th International Conference on Computer Science and Information Technologies (CSIT)*. doi: <https://doi.org/10.1109/csit61576.2023.10324217>
9. Thaher, T., Chantar, H., Too, J., Mafarja, M., Turabieh, H., Houssein, E. H. (2022). Boolean Particle Swarm Optimization with various Evolutionary Population Dynamics approaches for feature selection problems. *Expert Systems with Applications*, 195, 116550. doi: <https://doi.org/10.1016/j.eswa.2022.116550>
10. Syan, C. S., Ramsobag, G. (2019). Maintenance applications of multi-criteria optimization: A review. *Reliability Engineering & System Safety*, 190, 106520. doi: <https://doi.org/10.1016/j.res.2019.106520>

✉ **Oksana Mulesa**, Doctor of Technical Science, Professor, Department of Software System, Uzhhorod National University, Uzhhorod, Ukraine, e-mail: Oksana.mulesa@uzhnu.edu.ua, ORCID: <https://orcid.org/0000-0002-6117-5846>

Evgen Yakob, Postgraduate Student, Department of International Economic Relations, Uzhhorod National University, Uzhhorod, Ukraine, ORCID: <https://orcid.org/0009-0002-3601-2882>

Petro Valko, Postgraduate Student, Department of Software System, Uzhhorod National University, Uzhhorod, Ukraine, ORCID: <https://orcid.org/0009-0001-9501-0126>

Oleksandra Sviezhentseva, Department of Information Systems and Technologies, Uzhhorod National University, Uzhhorod, Ukraine, ORCID: <https://orcid.org/0009-0001-8891-2594>

Dmytro Marhitych, Postgraduate Student, Department of Software System, Uzhhorod National University, Uzhhorod, Ukraine, ORCID: <https://orcid.org/0000-0003-0446-5238>

 ✉ Corresponding author

UDC 004.738.5:681.5.017

DOI: 10.15587/2706-5448.2024.300745

**Iryna Zinko,
Olha Kravchenko,
Dmytro Syvoglaz**

DESIGNING AN INTERNET OF THINGS SOLUTION FOR MONITORING VITAL SIGNS

The object of study is the process of monitoring vital signs using an automated system based on an Internet of Things (IoT) solution. The study investigates and analyses the best existing solutions for continuous monitoring of human health. The research is important in the context of a possible pandemic and general health monitoring.

An IoT model of a solution for monitoring and analyzing vital signs in patients is proposed. The project involves the creation of hardware and software for tracking vital signs. The interaction of the two parts will ensure that the main task is to obtain the result and analyze the indicators of vital functions of the human body. The hardware is implemented using devices for scanning data on heart rate, temperature, saturation, and the ability to track electrocardiograms. It is possible to transmit data on the state of the body. The position of the sensors attached to the body is taken into account in case they come off. The device itself should be placed on the human body in the area of the front chest wall, wrists, and ankles. The device is also programmed to respond to sudden changes in these values. The software implementation is based on a web-based interface. The design of the final solutions for the interaction between the local and intermediate server was implemented using Django and Python. The ability to administer the intermediate server of the client's time zone was written using HTML, CSS, and JavaScript. The use of the IoT solution allows monitoring the indicators of vital functions of the body and their analysis. A scheme of information exchange in the system for monitoring health indicators has been built.

Keywords: vital signs monitoring, client-server architecture, information system, Internet of Things, IoT.

Received date: 14.02.2024

Accepted date: 03.04.2024

Published date: 09.04.2024

© The Author(s) 2024

This is an open access article
under the Creative Commons CC BY license

How to cite

Zinko, I., Kravchenko, O., Syvoglaz, D. (2024). Designing an Internet of Things solution for monitoring vital signs. *Technology Audit and Production Reserves*, 2 (2 (76)), 17–24. doi: <https://doi.org/10.15587/2706-5448.2024.300745>

1. Introduction

Everyone faces health problems in their lives. It can be a common cold or a chronic illness. It is an important and integral part of our lives. This paper deals with the research side of continuous monitoring of vital signs. It is proposed

to simplify the conduct of such studies and better record information using the created database and sensors.

An analysis of existing solutions shows that there are some automated systems, such as an ECG system from Norav Medical [1] or a monitoring system from Cardiomo [2]. In today's world, many companies use microcomputers [3]

or microcontrollers [4] in their operations, which make it possible to work easily and quickly without any extra costs. Some devices contain an interface that can be accessed by connecting to a monitor, but microcontrollers do not have this feature, so it is firstly necessary to write a programme on your own computer and download it to the device. 4 types of devices for further use: Raspberry Pi [5], Asus Tinker Board [6], LattePanda [7], and Arduino [8] are analyzed in this paper. Two more well-known and two less well-known devices that can be used in the field of medicine were selected.

The research of various scientists from around the world is also considered, which also raises the issue of such a monitoring methodology [9, 10]. These studies provide a good overview of the problem of data monitoring and solutions.

Thus, the *object of research* is the process of monitoring vital signs of the body using an automated system based on the Internet of Things (IoT) solution. *The aim of research* is to build an IoT solution project for monitoring vital body functions and analyze them.

2. Materials and Methods

The analysis of microcontrollers and microcomputers was carried out, and the optimal hardware for the practical implementation of the IoT solution was selected. In Fig. 1 shows a graph of the popularity of well-known manufacturers of single-board computers: Raspberry Pi, Arduino, Asus Tinker Board, and Latte Panda.

The graph curves corresponding to Raspberry Pi and Arduino are marked with a value of 50 and over 75, respectively.

This indicates their relative popularity or usage. The Asus Tinker Board and Latte Panda are not as popular in use because they are little known. According to the data analyzed, the best decision was to choose Arduino for further work. In order to make sure of the choice, an analysis was carried out, which showed that the microcomputer is easy to use. Arduino is easy to install and use. Its simple language style and intuitive interface make it accessible even to beginners. There is a large active community of Arduino users who are happy to help and share their knowledge. This makes the product more convenient for learning and development. Arduino is easy to expand with additional components and modules (shields). This allows developers to change the functionality of the project according to their needs. A large number of Arduino-compatible components, modules, and sensors are available.

An additional platform was also selected to expand the capabilities of the e-Health sensor Shield controller, Fig. 2. The device is designed to be used with microcontroller platforms such as Arduino or Raspberry Pi, which makes it easy to integrate into a variety of health and wearable electronics projects. It provides the ability to capture real-world health data and use it for analysis, tracking, and storage.

In the process of creating medical instruments that can collect heart signals, it is of great importance to choose sensors that ensure measurement accuracy and reliability of the results (Fig. 3). In our case, it is possible to choose the JP400 body temperature sensor (China), the MAX30102 [12] pulse oximeter-saturator (China) and the AD8232 electrocardiograph (China).

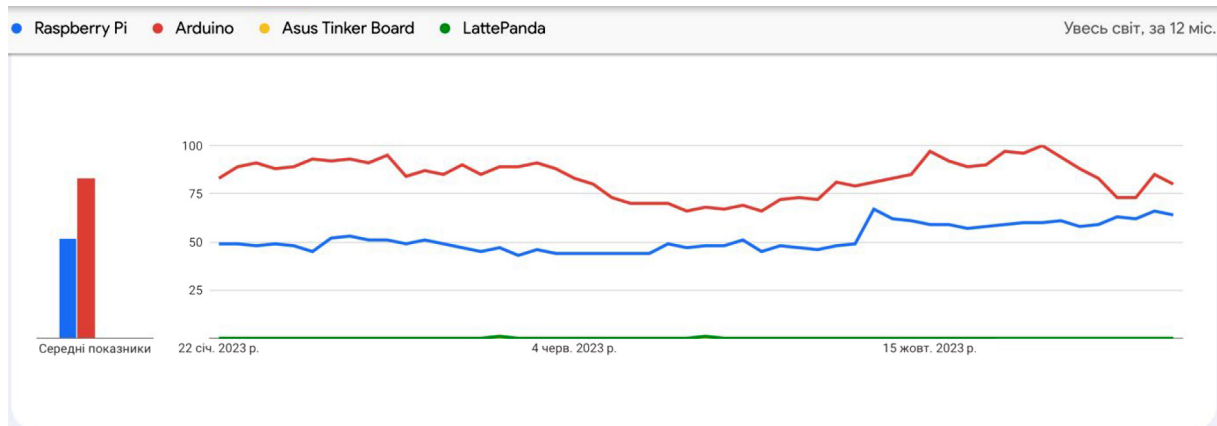

Fig. 1. Popularity of single-board computers in Google Trends [9]

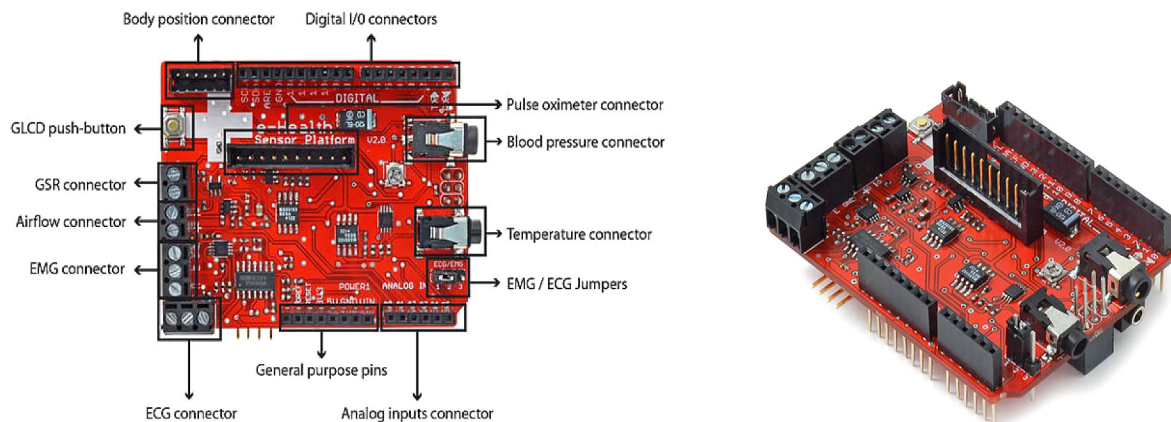

Fig. 2. E-Health Sensor Shield V2.0 for Arduino [11]

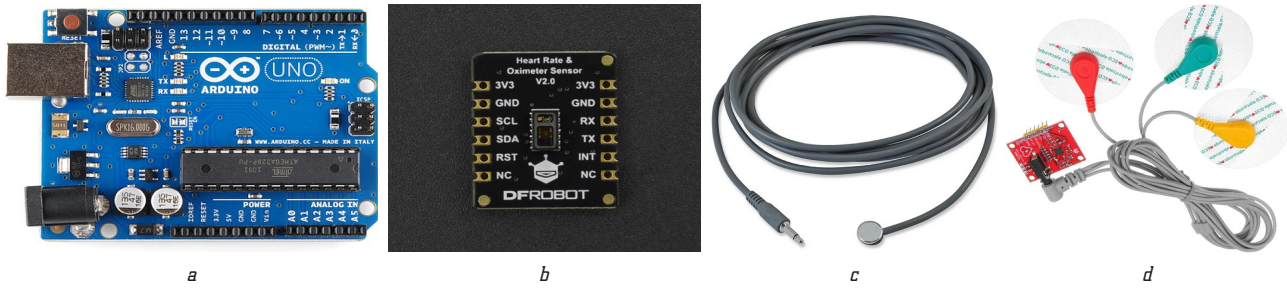

Fig. 3. Hardware for the IoT solution for monitoring vital signs:
a – Arduino UNO; b – DFRobot pulse oximeter-saturation monitor [13]; c – body temperature sensor [14]; d – ECG sensors [15]

For the following reasons, AD8232 was chosen as the main sensor for measuring the electrical activity of the heart: AD8232 is characterized by high accuracy and sensitivity, which guarantees clear electrocardiac signals. The sensor is used in many medical and home applications, so it is accessible and reasonably priced for our project. For the following advantages, it is chosen to use a heart rate monitor and thermometer (MAX30102) to measure heart rate and blood oxygen saturation: The MAX30102 shows the oxygen saturation of the blood, which is important for determining the efficiency of blood circulation and heart function. The sensors can accurately measure heart rate and oxygen saturation using infrared light and photodiodes. The JP400 sensor was chosen for body temperature measurement because of the following advantages: body temperature, which can be accurately determined by the sensor, is an important indicator for assessing the patient’s overall health and evaluating their condition. The JP400 is lightweight and compact, making it ideal for mobile medical applications, which is important for the development of portable monitoring.

The choice of AD8232, MAX30102, and JP400 transducers depends on their technical characteristics, measurement accuracy, availability, and ability to be used in medical research. These sensors work together to provide a complete set of data to monitor a patient’s cardiovascular health and overall health.

Working with the health monitoring sensors in Fig. 4 usually includes the following steps:

1. *Select and purchase sensors.* First, it is necessary to select the sensors that will be used for health monitoring. Depending on the goals and needs of the user, different types of sensors can be used, such as heart rate monitors, thermometers, motion sensors, sleep sensors, etc.
2. *Install the sensors.* Once the required sensors have been selected, they must be installed. Installation may vary depending on the type of sensor and its purpose. For example, for heart rate monitors, it is necessary to attach them to your body, and for motion sensors, it is necessary to place them in an appropriate location.
3. *Connect to the device.* Once the sensors have been installed, they must be connected to a suitable device. This can be a smartphone, tablet, or other medical device that can read data from the sensors.
4. *Sensor calibration.* Certain types of sensors, such as heart rate monitors, may need to be calibrated to ensure accurate data collection. Calibration is usually done using special software or by following the manufacturer’s instructions.
5. *Data collection and analysis.* Once the sensors have been connected and calibrated, they start collecting data about the user’s health status.

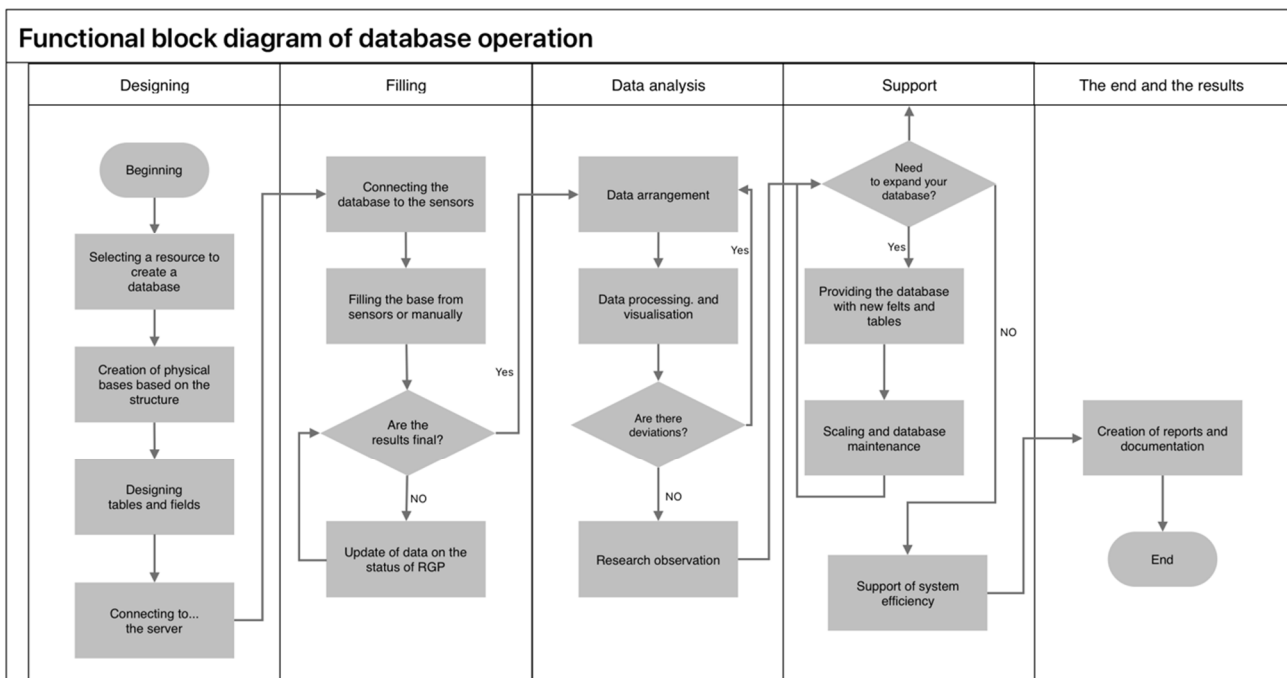

Fig. 4. Functional block diagram of working with sensors for monitoring

For the convenient use of virtual environments, let's use ANACONDA [14] as an auxiliary tool. Virtual environments are isolated environments that allow to create and manage separate Python installations for different projects.

The goal is to create your own «ecosystem» with the necessary frameworks, libraries and other components, so the use of virtual environments is an important aspect of the work. The application created using the Django framework is designed to receive data from the greeting sensors and store it in SQLite database. Using Django, this framework provides a simple mechanism for interacting with the database. Web technologies such as HTML, CSS and JavaScript were used to display information and interact with the user. HTML is used to create the structures of the web page, CSS is used to give it appearance and style, and JavaScript is used to implement dynamic elements and interact with the server. The webpage has an interface that displays data from vital signs sensors in a user-friendly format. JavaScript allows data to be constantly updated without reloading the page and allows users to interact with the application, for example, send commands or filter data.

In the digital age, the use of the IoT in healthcare is becoming increasingly important. Modern hospitals are implementing sophisticated IoT systems that allow them to collect and analyze data on patients' condition in real time. Let's look at a detailed architecture that uses wireless access (WAP) and includes four key layers in Fig. 5.

Perception Layer. This first layer plays a key role in collecting data from IoT devices in the hospital. Sensors placed on patients collect a variety of data, such as body temperature and heart rate. For doctors, this is important information for accurate diagnosis and effective treatment.

Network Layer. The use of a wireless Wi-Fi network ensures that this data is quickly transferred to the next steps. Additionally, Bluetooth technology allows clinicians to access the data when there is no network.

Middleware Layer. This layer uses cloud-based database storage to process and store large amounts of information. From the cloud storage, data is analyzed in real time,

allowing doctors to quickly identify anomalies and make information decisions.

Application Layer. The last layer provides the display and interaction with the processed data. The use of HTML pages makes the interface accessible on a variety of devices such as laptops, smartphones and PCs. Doctors can monitor and manage patients' condition using a user-friendly and efficient interface.

The architecture of the IoT system in medicine allows for efficient collection, transmission and processing of patient data. This innovative system contributes to improved diagnostics and the provision of quality medical care. In the future, the development and improvement of this architecture may lead to even greater opportunities in the field of medical technology.

3. Results and Discussions

3.1. Results. To develop the software part of the project, Anaconda and Python were installed on the Arduino UNO. The auxiliary Django framework downloaded [16] is also to conveniently configure data transmission, recording, and the server on which the system will run. The Arduino IDE [17] was chosen to work with the microcomputer. First of all, the sensors were connected to the Arduino in accordance with the instructions and the required connection foams. The availability of the necessary libraries for each sensor was ensured. To connect the Arduino with Python Django and transfer data, let's use the communication mechanisms between the Arduino and the Django server. One way is to use a data transmission medium, such as Wi-Fi, to send data from the Arduino to the Django server. A model was created that will be used to store the received data using django.db models and special classes. A view that will process the data from the microcomputer and a template for displaying it on the page in an attractive and intuitive way have been written. The URL route for the view has been added. Thus, the data from the Arduino is sent via Wi-Fi to the Django server, which stores the data in the database and displays it on the health_data page.

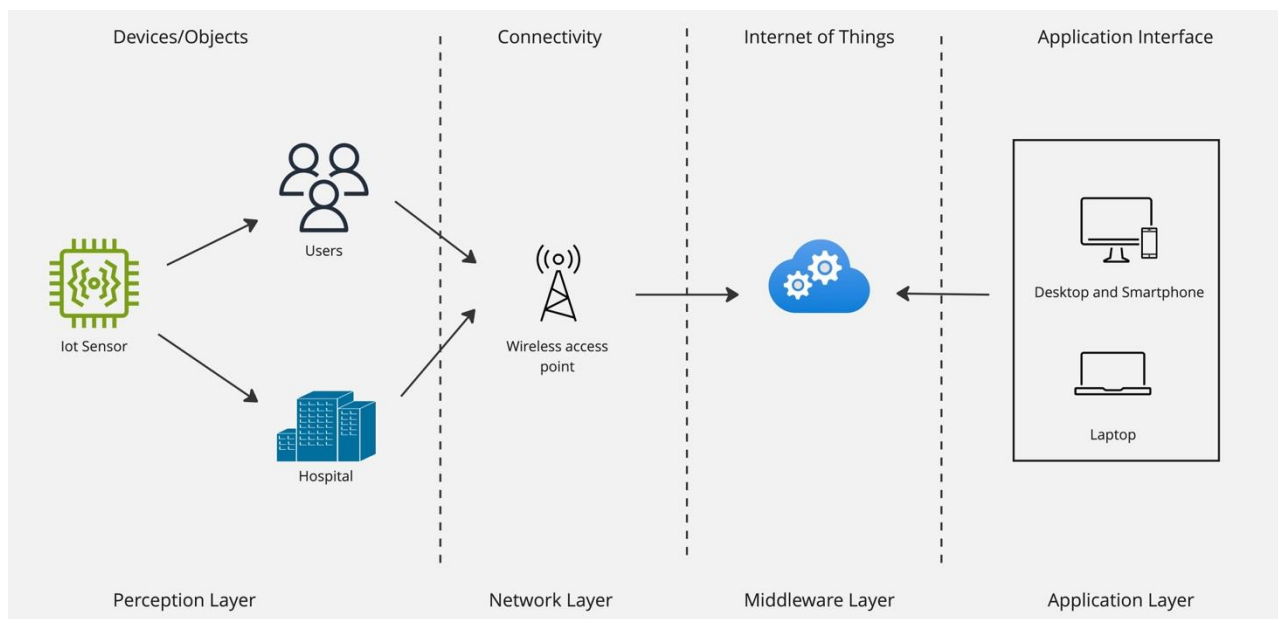

Fig. 5. IoT system architecture

Only inexpensive off-the-shelf chips and sensors with proven efficiency and stability are used in prototyping. Therefore, based on the information about each sensor of the device on the Internet, any part of the device can be easily replaced or repaired by a technician or an ordinary user.

The server was created and operated using Python and the Django framework. All information recorded and transmitted by the sensors was recorded and stored in SQLite databases [18]. This is a convenient and reliable solution that allows to view the recorded data and edit it if necessary.

Fig. 6 shows the physical model of the database for the IoT monitoring system. The physical database model provides detailed information about the data representation. This model is used to create the database itself, as it includes all the necessary data and details for its creation. The physical model specifies the types and directions of relationships between tables. The physical database model also takes into account the dimensionality and types of fields.

For easy access to information by ordinary users, healthcare professionals or scientists, a project website was created where they could view information, add patient data, and manually record readings if necessary (Fig. 7). The ability to view scientists or healthcare professionals was also added, as shown in Fig. 8, who are involved in patient monitoring, so each person is assigned a unique employee number.

Fig. 9 shows the patient’s home page, which contains their full information, such as their name and details. In the center is a table with the primary data: ID, test date, heart rate, body temperature, general condition, and additional notes. It is also possible to add data manually if there is any inaccuracy or additional information about the patient needs to be added.

To start the IoT device, it is connected to the micro-controller’s power supply. After loading the operating system, let’s use special software to connect to the Arduino UNO [19] and call the local Django server. The device is ready for data transmission and writing to the database. The website provides information on the status of the patient connected to the sensors. The information is sent in JSON format via the API, and the website receives visual information with the patient by downloading a CSV file.

The basis of the IoT device is the Arduino Uno and the optional E-Health Sensor Shield V2.0 module, which simplifies and improves the operation of the pulse oximeter-saturation, body temperature and ECG sensors. The micro-computer is designed with a Li-Po (lithium-ion-polymer) battery socket that is suitable for this type of battery. These types of batteries supply 3.7 V, can be recharged, and can provide more energy than other lithium batteries. This allows to make a completely portable device that does not need to be connected to power directly.

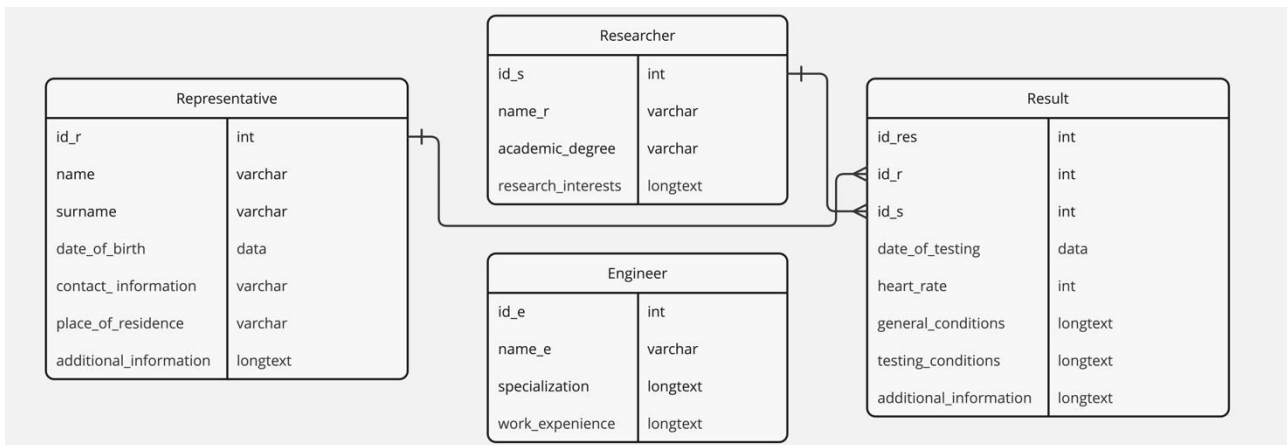

Fig. 6. Physical model of the monitoring service database

Representative group

Name	Surname	Date of birth	Contact details	Place of residence	Start
Gerald	Humphrey	Aug. 5, 2003	+380623971912	Shumsk, Ternopil Oblast	Go to research
Liam	Williamson	Jan. 2, 2002	+380718567772	Kyiv, UA	Go to research
Lily-Rose	Dante	Oct. 29, 2001	+380438385151	Zaporizhia, UA	Go to research
Julia	Kim	Feb. 8, 2002	+380579044873	Kyiv, UA	Go to research
Hayden	Wright	April 17, 2003	+380977536096	Kyiv, UA	Go to research
Seren	Meadows	April 14, 2001	+380671230934	Lviv, UA	Go to research
Kiona	Tyler	Dec. 12, 1000	+380912431623	Kyiv, UA	Go to research

Add new representatives?

[Add](#)

Fig. 7. Home page of the website of the project for monitoring vital signs

Researchers

Add new Researcher?

[Add](#)

Personal ID	Surname	Academic degree	Research interests
1	Smith	MD	Cognitive behavioral therapy for anxiety disorders
2	Johnson	MD, PhD	Genetic factors in the development of schizophrenia
3	Davis	MD	Cardiac rehabilitation and secondary prevention

Fig. 8. Page with data on employees under observation

Personal details of Lily-Rose Dante

Height: 165 cm; Weight: 75 kg; Chronic illnesses: none; Lifestyle: active; Not currently taking any medications; No excessive physical exertion for the body.

Results of motinoring

Personal ID	Date of testing	Heart rate	Body temperature	General conditions	Additional information
Name: Lily-Rose	April 26, 2023	70 BPM	36.6 °C	Good	Nothing special
Name: Lily-Rose	April 26, 2023	90 BPM	36.4 °C	Active	Nothing special
Name: Lily-Rose	April 26, 2023	76 BPM	36.6 °C	10-15 min after activity	Nothing special
Name: Lily-Rose	April 26, 2023	65 BPM	37 °C	Calm	Nothing special
Name: Lily-Rose	April 26, 2023	120 BPM	36.5 °C	Active	Nothing special
Name: Lily-Rose	April 26, 2023	75 BPM	36.5 °C	10-15 min after activity	Nothing special
Name: Lily-Rose	Dec. 12, 1222	123 BPM	36.6 °C	123	123

If you want to add new results:

[Add results](#)

Fig. 9. Display of patient data results

Since one of the key issues determining the success of the project is pricing, it is worth exploring the possibility of using a simpler and, therefore, cheaper version of the Arduino microcomputer [20]. Based on the data obtained, the Arduino UNO model was chosen because it provides sufficient power for the entire device and does not have any unnecessary functions or features. It was also important that the model was portable and did not tie a person to one place, which was achieved by using a battery.

3.2. SWOT analysis for an IoT-based vital signs monitoring system

Strengths:

1. *Real-time monitoring.* The system provides continuous and instantaneous monitoring of vital signs, allowing to respond immediately to any irregularities or emergencies.
2. *Comprehensive data collection.* The device collects a wide range of vital signs including heart rate, temperature and electrocardiograms, providing a holistic view of the patient's health.
3. *Adaptive equipment.* The device is programmed to respond to sudden changes in vital signs, improving its ability to detect and alert healthcare professionals to potential health problems.

4. *User-friendly interface.* The web interface offers an accessible and user-friendly platform for both healthcare professionals and patients to monitor and analyze vital signs data.

Weaknesses:

1. *Dependence on portable devices.* The accuracy and effectiveness of the system is highly dependent on the correct placement and attachment of the wearables to the patient's body. Any disconnection can lead to inaccurate measurements.
2. *Limited coverage.* Sensor placement on the front of the chest, wrists and ankles can limit coverage of certain vital signs, potentially missing important health indicators.
3. *Upfront costs.* Hardware and software development, especially the creation of an IoT infrastructure, can require significant upfront costs.
4. *Technological dependence.* The functionality of the system depends on a stable Internet connection and proper operation of both hardware and software components.
5. *Data security issues.* With the transmission of sensitive health data comes the inherent threat of data leakage or unauthorized access, requiring robust security measures.

Opportunities:

1. *Pandemic preparedness.* The constant threat of pandemics highlights the relevance of health monitoring systems.

The system can play an important role in identifying and managing health crises.

2. *Integration with healthcare systems.* The system can be integrated into existing healthcare infrastructure, providing a seamless flow of vital signs data into electronic health records for comprehensive patient management.

3. *Remote patient monitoring.* With the growth of telemedicine, the system can be adapted for remote patient monitoring, allowing healthcare professionals to track patients in real time from a distance.

4. *Customization and scalability.* The modular design allows to customize the system to meet specific healthcare needs and expand it for widespread implementation.

5. *Research and development opportunities.* Continued advances in sensor and data analysis technologies open up opportunities for further research and development, improving system capabilities.

Threats:

1. *Regulatory compliance.* Stringent regulatory requirements for medical technology can make it difficult to obtain the necessary approvals and certifications for a system.

2. *Privacy concerns.* Growing attention and concerns about data privacy may lead to patient resistance or reluctance to use such monitoring systems.

3. *Competitive environment.* The growing interest in health monitoring technologies may lead to increased competition, requiring the company to maintain leadership in innovation and functionality.

4. *Technological obsolescence.* Rapid technological change can make some system components obsolete over time, requiring regular updates and upgrades.

5. *Unforeseen technical problems.* Unexpected technical problems or issues with hardware or software components can disrupt system performance and affect reliability.

3.3. Discussion. The research on the development of a system for collecting and processing medical data using the IoT has significant practical potential and can contribute to the improvement of medical practice. The system developed as part of this research allows for the efficient collection, transmission and processing of patient data, which opens up opportunities for improved diagnostics and the provision of quality medical care. For example, the collected data can be used to monitor patients' condition in real time, as well as to analyze the duration and effectiveness of treatment.

The limitations of the study include technical limitations associated with the selected hardware and software, as well as the possibility of the need for further optimization of the system for optimal functioning in real medical practice. For example, it may be necessary to develop additional measures to ensure the security and confidentiality of patient data.

The conditions of martial law in Ukraine may have an impact on the implementation of the findings of this study. For example, in the context of a military conflict, it may be more difficult to ensure the stable functioning of the communication network for the transmission of medical data, and there may be additional requirements to protect data confidentiality due to potential cybersecurity threats.

In summary, the system developed in this study is only the first step towards the development of medical technologies based on the Internet of Things. Further research can be aimed at expanding the system's functionality, improving its efficiency and safety, and exploring the possibilities of

its integration with other medical technologies to achieve an integrated approach to medical diagnosis and treatment.

4. Conclusions

The research is dedicated to the development of a system for collecting and processing medical data using the IoT. The analysis of microcontrollers and microcomputers revealed that the best solution for this system is to use Arduino. The IoT device is based on the Arduino Uno and the E-Health Sensor Shield V2.0 add-on module, which simplifies the operation of the sensors. AD8232, MAX30102, and JP400 sensors with high accuracy and sensitivity were used for data collection. To process the data, a server based on Python and the Django framework was created, which stores information in SQLite databases. The project website allows to view and add patient data.

The created system efficiently collects, transmits and processes medical data, which helps to improve diagnostics and provide quality medical care. The modular design of the device makes it easy to replace or repair its parts.

The main contribution of the study is the development and implementation of an innovative system for collecting and processing medical data based on the Internet of Things. Further research can focus on expanding the functionality, improving the efficiency and security of the system, as well as integrating it with other medical technologies for an integrated approach to medical diagnosis and treatment.

Conflict of interest

The authors declare that they have no conflict of interest in relation to this research, whether financial, personal, authorship or otherwise, that could affect the study and its results presented in this paper.

Financing

The study was performed without financial support.

Data availability

The paper has no associated data.

Use of artificial intelligence

The authors confirm that they did not use artificial intelligence technologies when creating this work.

References

1. *Norav medical.* Available at: <https://www.noravmedical.com>
2. *Cardiomo monitoring heart health.* Available at: <https://www.cardiomo.com>
3. Shea, S. (2018). *Microcomputer.* Available at: <https://www.techtarget.com/iotagenda/definition/microcomputer>
4. Lutkevich, B. (2019). *Microcontroller.* Available at: <https://www.techtarget.com/iotagenda/definition/microcontroller>
5. *Raspberry Pi.* Available at: <https://www.raspberrypi.org>
6. *Asus Tinker Board.* Available at: <https://www.asus.com/networking-iot-servers>
7. *LattePanda.* Available at: <https://www.lattepanda.com>
8. *Arduino.* Available at: <https://www.arduino.cc>
9. *Google Trends.* Available at: <https://trends.google.com/trends/>
10. *e-Health Sensor Shield.* Available at: <https://www.arrow.com/en/products/10269/libelium-comunicaciones-distribuidas-sl>

11. *The DFRobot heart rate and oximeter sensor integrates the Maxim MAX30102 chip.* Available at: https://wiki.dfrobot.com/Heart_Rate_and_Oximeter_Sensor_V2_SKU_SEN0344
12. *Model JP403 – Medical Temperature Sensor of Adult Body Surface.* Available at: <https://www.medical-xprt.com/products/model-jp403-medical-temperature-sensor-of-adult-body-surface-673919>
13. *ECG Monitoring with AD8232 ECG Sensor & Arduino.* Available at: <https://how2electronics.com/ecg-monitoring-with-ad8232-ecg-sensor-arduino/>
14. *ANACONDA.* Available at: <https://www.anaconda.com/>
15. *Django framework.* Available at: <https://www.djangoproject.com>
16. *Arduino Software.* Available at: <https://www.arduino.cc/en/software/>
17. *SQLite.* Available at: <https://www.sqlite.org/index.html>
18. *Python Developer's Guide.* Available at: <https://devguide.python.org/>
19. *What is Arduino.* Available at: <https://www.kanda.com/what-is-arduino.php>
20. *Microcomputer-controlled devices for human implantation.* Available at: <https://secwww.jhuapl.edu/techdigest/Content/techdigest/pdf/V04-N02/04-02-Fischell.pdf>

Iryna Zinko, Department of Information Systems and Technologies, Taras Shevchenko National University of Kyiv, Kyiv, Ukraine, ORCID: <https://orcid.org/0009-0000-6118-0023>

✉ **Olha Kravchenko**, PhD, Associate Professor, Department of Information Systems and Technologies, Taras Shevchenko National University of Kyiv, Kyiv, Ukraine, ORCID: <https://orcid.org/0000-0002-9669-2579>, e-mail: kravchenko.olga0803@gmail.com

Dmytro Syvoglaz, Postgraduate Student, Department of Information Technologies, Cherkasy State Technological University, Cherkasy, Ukraine, ORCID: <https://orcid.org/0000-0002-6806-839X>

✉ Corresponding author