

DIGITALES ARCHIV

ZBW – Leibniz-Informationszentrum Wirtschaft
ZBW – Leibniz Information Centre for Economics

Kabanyachyi, Volodymyr; Ibrahimoglu, Beycan

Article

Consideration of the problem of motion cueing along angular degrees of freedom on flight simulators

Reference: Kabanyachyi, Volodymyr/Ibrahimoglu, Beycan (2023). Consideration of the problem of motion cueing along angular degrees of freedom on flight simulators. In: Technology audit and production reserves 6 (1/74), S. 6 - 12.
<https://journals.uran.ua/tarp/article/download/293498/287360/679942>.
doi:10.15587/2706-5448.2023.293498.

This Version is available at:
<http://hdl.handle.net/11159/653449>

Kontakt/Contact

ZBW – Leibniz-Informationszentrum Wirtschaft/Leibniz Information Centre for Economics
Düsternbrooker Weg 120
24105 Kiel (Germany)
E-Mail: [rights\[at\]zbw.eu](mailto:rights[at]zbw.eu)
<https://www.zbw.eu/econis-archiv/>

Standard-Nutzungsbedingungen:

Dieses Dokument darf zu eigenen wissenschaftlichen Zwecken und zum Privatgebrauch gespeichert und kopiert werden. Sie dürfen dieses Dokument nicht für öffentliche oder kommerzielle Zwecke vervielfältigen, öffentlich ausstellen, aufführen, vertreiben oder anderweitig nutzen. Sofern für das Dokument eine Open-Content-Lizenz verwendet wurde, so gelten abweichend von diesen Nutzungsbedingungen die in der Lizenz gewährten Nutzungsrechte.
<https://zbw.eu/econis-archiv/termsfuse>

Terms of use:

This document may be saved and copied for your personal and scholarly purposes. You are not to copy it for public or commercial purposes, to exhibit the document in public, to perform, distribute or otherwise use the document in public. If the document is made available under a Creative Commons Licence you may exercise further usage rights as specified in the licence.



**Volodymyr Kabanyachyi,
Beycan Ibrahimoglu**

CONSIDERATION OF THE PROBLEM OF MOTION CUEING ALONG ANGULAR DEGREES OF FREEDOM ON FLIGHT SIMULATORS

The object of research is motion cueing along angular degrees of freedom on flight simulators of non-maneuvering aircraft. One of the most problematic places is lack of statement and effective solution of the problem to ensure high-quality motion cues along angular degrees of freedom on flight simulators, which would correspond to motion cues along angular degrees of freedom in real flight with the same control actions. In the course of the research, on the basis of the peculiarities of human movement perception, a set of characteristic attributes of perception of motion cues is determined: character, direction, duration, intensity and time of motion perception (according to Gibson's perception theory). Based on the system approach principles, the mathematical formulation of the solution to the problem of motion cueing along angular degrees of freedom on flight simulators of non-maneuvering aircraft is used. Such approach made it possible, taking into account the existing constructive resource of flight simulator motion system, to bring as close as possible motion cueing along angular degrees of freedom on flight simulators of non-maneuvering aircraft to motion cues along angular degrees of freedom in real flight with the same control actions. Due to this the character and direction of motion cues fully correspond to the real motion cues, the difference between the perception time of motion cues on airplane and simulator is minimal and meets the current requirements. The duration and intensity of the motion cue perception on simulator are proportional duration and intensity of motion cue perception on airplane. Such approach significantly improves the quality of training and retraining of pilots on flight simulators. Implementation of the developed problem formulation on aircraft simulators, in particular on An-74TK-200, showed its high efficiency. In the future, the proposed approach can be used on flight simulators of aircraft developed in Ukraine and modernization of operated flight simulators.

Keywords: *flight simulator, motion system, motion cueing, character, direction, duration, intensity and time of motion perception.*

Received date: 26.10.2023

Accepted date: 15.12.2023

Published date: 19.12.2023

© The Author(s) 2023

This is an open access article

under the Creative Commons CC BY license

How to cite

Kabanyachyi, V., Ibrahimoglu, B. (2023). Consideration of the problem of motion cueing along angular degrees of freedom on flight simulators. *Technology Audit and Production Reserves*, 6 (1 (74)), 6–12. doi: <https://doi.org/10.15587/2706-5448.2023.293498>

1. Introduction

Flight simulation may be defined as creating, in real time under non-flight conditions, the performance and operation of a specific aircraft including its environment, which will respond to a pilot with the required fidelity to elicit pilot behavior as if he or she were flying the actual aircraft. Flight simulators have been applied principally to two applications: aircraft research and development and aircrew training.

When the pilot applies control forces to maneuver the aircraft, he or she perceives the changes motion cues associated with maneuvering of the aircraft. Motion cueing along angular degrees of freedom on flight simulators is of great importance, first of all, for pilot training. All the early pilot training devices from the Wright Brothers' simulator to Link's «blue box» tried to simulate airplane angular movements. Currently, motion cueing along angular degrees of freedom is a mandatory component of all full flight simulators. The importance of motion cueing along angular degrees of freedom

is due to the problem faced by the first pilots: the need to respond adequately to the atmospheric turbulence that caused aircraft angular movements.

Many investigations of motion cueing were conducted. Thus, spectral density of control column deviations, piloting error and used displacement resource of control lever without and with motion system is described in [1]. The paper describes assessment of motion cueing influence on piloting. This assessment show worsening of piloting characteristics on simulators without a motion system.

Paper [2] discusses mathematical problems of dynamic flight simulation on the basis of theoretical mechanics. On the basis of this approach, it is shown that six-degrees of freedom motion systems with 2 m jack length are unsuitable for motion cueing.

In [3], the need for use of vestibular models for design and evaluation of flight simulator motion is shown due to influence of motion perception on pilot training on flight simulators.

Study [4] discusses motion cueing in piloted flight training simulators, and presents the factors that must be taken into account when assessing the need for, and benefits of, a motion platform so that informed decisions can be taken as to its training value. These factors include the role of the simulator, the handling qualities of the vehicle concerned, the tasks the pilot is required to fly, the performance it is expected to achieve and whether training considerations require it to use a similar control strategy and control activity in the simulator as in the aircraft.

In study [5], determination of force cueing requirements for tactical combat flight training devices is shown. The use of force cueing requirements is necessary to significantly improve the quality of flight training devices.

Paper [6] prescribes the rules governing the initial and continuing qualification and use of all aircraft flight simulation training devices used for meeting training, evaluation, or flight experience requirements for flight crewmember certification or qualification. No sponsor may use or allow the use of or offer the use of an flight simulator for flight crewmember training or evaluation or for obtaining flight experience to meet any requirement unless the sponsor has established and follows a quality management system, currently approved by the National Simulator Program Manager, for the continuing surveillance and analysis of the sponsor's performance and effectiveness in providing a satisfactory flight simulator for use on a regular basis.

In [7], a story of evolution of motion in flight simulators is considered and analyzed. It is shown that human body senses accelerations using the vestibular apparatus within the inner ear. The vestibular apparatus senses two kinds of acceleration, rotational and linear. Rotational acceleration is that produced by movement of the head in any of the planes so familiar to us. Otoliths sense translation of movement (accelerations) in vertical and lateral planes, including gravity.

Paper [8] reports that development of the Link Flight Trainer was a worldwide contribution. It was among the first mechanical devices used to simulate actual processes. The legacy of the Link Flight Trainer continues today, with simulators being used for a wide range of training activities, including commercial, military and space flight.

Paper [9] gives preliminary results of a study on the effect of simulator platform motion on initial training of airline pilots that have never flown the simulated airplane. Two earlier studies were conducted in the framework of the Federal Aviation Administration/Volpe Flight Simulator Human Factors Program examining the effect of simulator motion on recurrent training and evaluation of airline pilots have found that in the presence of a state-of-the-art visual systems, motion provided by a six-degree-of-freedom platform-motion system only minimally affected evaluation, and did not benefit training, of pilots that were familiar with the airplane.

The authors of [10] report a presents the FAA/Volpe Center's Flight Simulator Fidelity Research Program, which is part of the Federal Aviation Administration's effort to promote the effectiveness, availability and affordability of flight simulators. This initiative will become increasingly critical with the anticipated regulatory changes mandating the use of simulators in airline pilot training and evaluation, dramatically reduced pilot new-hire experience levels and growing operational complexity. Initial research on the training effectiveness of a fixed-base simulator with a wide field-of-view visual system compared to a like system having platform motion failed to find an operationally significant ef-

fect of motion. This paper is declared a work of the U.S. Government and is not subject to copyright protection in the United States.

Results of a number of simulator investigations were critically reviewed in [11]. Fidelity is defined in this context as a degree to which simulator accurately reproduce motion cues. The importance of providing motion information for the specific ranges of aircraft dynamics has long been recognized. From the pilot's point of view, motion adds realism and helps the execution of its task. Useful cues produced through motion to assist the pilot and improve its performance.

Motion cueing as in real flight is possible only with accurate reproduction of aircraft spatial motion. Due to limited constructive resources of flight simulator in comparison with aircraft resources, it is impossible to continuously monitor an aircraft movement. On the other hand, motion perception is important for pilot. Therefore, during motion cueing, it is important not movement of motion system itself, but created motion cues and how much their perception on flight simulator corresponds to real ones with same control actions.

The vestibular apparatus has several features that significantly effect on motion cue perception. First, an important parameter of vestibular analyzer functional state is latent period (latency time) – a time delay between a motion cue beginning and a motion sensation appearance. Second, due to the presence of specific formations in vestibular system receptors that function as threshold devices there is a threshold of vestibular analyzer sensitivity receptors. It is the minimum value of motion cue, which causes a noticeable motion sensation. In other words, below this threshold a person does not feel motion. Third, the human vestibular apparatus is characterized by adaptation to motion cues. Due to adaptation, perceived motion parameters may differ from the actual ones. Fourth, the vestibular response can be changed significantly with a person's mental state.

In Ukraine, there is a need to design flight simulators for designed aircraft and upgrading of existing flight simulators, which should meet modern requirements. So, problem of motion cueing along angular degrees of freedom is actual.

The aim of the research is to develop an effective method of motion cueing along angular degrees of freedom on non-maneuvering aircraft. This is necessary due to high cost of motion system and growing requirements for motion cues fidelity. Perception of motion cueing should be so close as possible to perception of real motion cues.

2. Materials and Methods

The impact of motion cueing on flight simulator effectiveness is determined by the piloting quality. Examples of its use in the process of roll stabilizing on flight simulator with and without motion system [1] are shown in Fig. 1–3. An increase in the deviations of control levers in the absence of motion cueing shows the difficulty of piloting on a flight simulator without motion system. The results of the assessment of the impact of the motion cueing on piloting on the flight simulator when the pilot parrying a stepped disturbance of high intensity (30 deg/s^2) and duration (over 5 s) show a significant decrease in the roll angle (Table 1). The delay of the pilot's reaction in the absence of motion system (0.7 s) is significantly greater than in the presence of motion system (0.4 s).

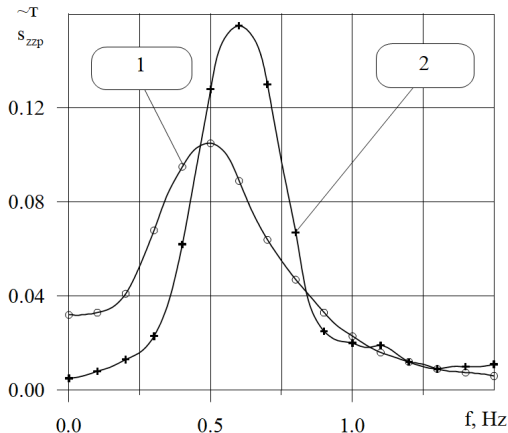

Fig. 1. Spectral density of control column deviations [1]:
1 – without motion system; 2 – with motion system

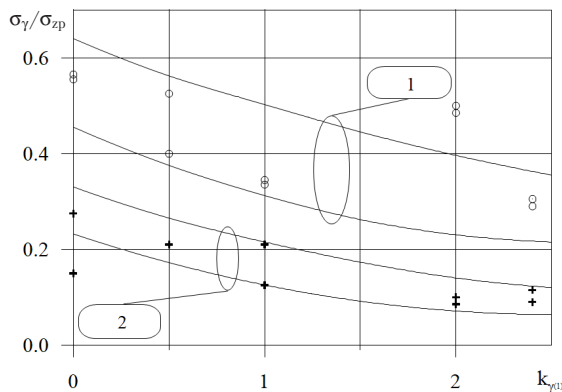

Fig. 2. Piloting error [1]:
1 – without motion system; 2 – with motion system

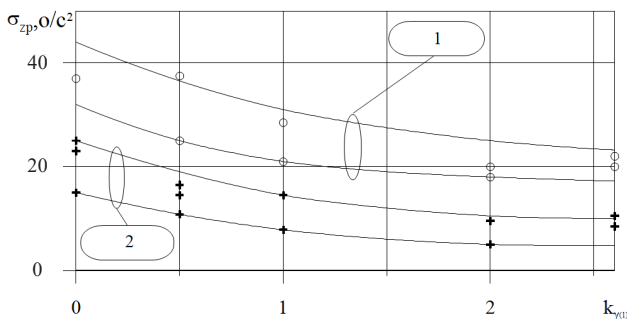

Fig. 3. Used displacement resource of control lever [1]:
1 – without motion system; 2 – with motion system

Assessment of motion cueing influence on piloting [1]

No. test		1	2	3	4	5	6	7	8	9	10	Average
Reaction time	with motion system	0.43	0.44	0.43	0.39	0.3	0.39	0.45	0.38	0.43	0.4	0.4
	without motion system	6.4	4.4	5.6	4.6	5.2	6.4	5.4	4.8	4.8	4.7	5.2
Roll deviation	with motion system	0.66	0.79	0.8	0.78	0.72	0.71	0.9	0.88	0.7	0.8	0.77
	without motion system	11.2	12.8	14.5	16.1	14	16	15.2	17	14	17	14.8

A motion cue is a physical action which can be perceived by human vestibular system according to aircraft position and motion in space. The vestibular system includes the

otolith organs and the semi-circular canals (Fig. 4). The otolith organs are sensitive to gravity and linear acceleration of the head. The semi-circular canals include three fluid-filled tubes oriented roughly at right angles to one another that are also circular and are imbedded in the temporal bones on each side of the head near the inner ear. The semi-circular canals respond to angular acceleration and velocity and aid in maintaining body equilibrium.

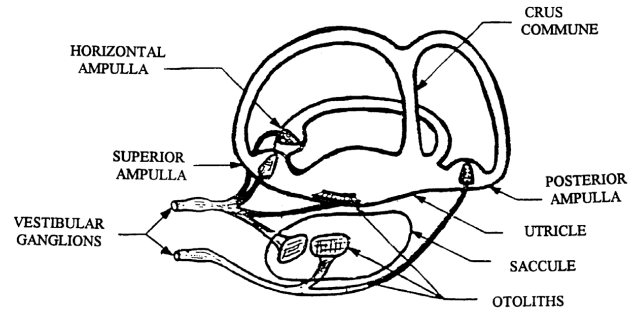

Fig. 4. Schematic sketch of the vestibular apparatus

For motion cueing a flight simulator compartment is mounted on a mobile basis – motion system. The movement of motion system creates motion cues.

3. Results and Discussion

The first mathematical model of semicircular canals was developed by Steinhausen. Subsequent works are a development of Steinhausen’s ideas for a satisfactory explanation of experimental data. Van Egmond, Groen, and Jonkins made attempts to model semicircular canals that perceive motion cues along angular degrees of freedom. Currently, Young’s model is the best in the form of a linear operator and a serially connected nonlinear element of the insensitivity zone type, which describes the perception threshold:

$$\ddot{\Omega} = a_0 \ddot{s} - a_1 \dot{\Omega} - a_2 \Omega \Omega_t, \quad (1)$$

where Ω , $\dot{\Omega}$, $\ddot{\Omega}$ are function of linear motion perception (indication of motion cue perception is exceeding of perception threshold with motion perception function), its first and second derivatives; Ω_t is motion perception threshold; \ddot{s} is angular acceleration; a_0 , a_1 , a_2 are coefficients of motion perception mathematical model.

Table 1

So far, it has not been possible to build a mathematical model of the vestibular analyzer that would describe all 100 % of its reactions. A problem in the vestibular system study is the lack of a mathematical description of adaptation (a decrease in sensitivity to repeated motion cue). A mathematical model that takes into account the neurological nature of the vestibular system and the processing of receptor signals in the human brain can accurately describe human perception of motion cueing.

A purely mechanical approach made it possible to create a mathematical model of the acceleration analyzer as a whole, which reflects more than 95 % of vestibular reactions.

However, the use of models describing only the perception threshold and the motion perception dynamics from motion cues can lead to the appearance of false motion cues. To avoid this, they need updating.

The research was conducted both on flight simulator and on non-maneuverable aircraft in real flight. Appropriate models of motion perception along linear degrees of freedom were constructed:

$$\Omega_\gamma(p) = \frac{9.8}{(p+0.055)(p+10)} \ddot{\gamma},$$

$$\Omega_{\gamma\dot{\gamma}} = 2.65^{+0.68}_{-0.74},$$

$$\Omega_\psi(p) = \frac{9.8}{(p+0.11)(p+10)} \ddot{\psi},$$

$$\Omega_{\psi\dot{\psi}} = 1.70^{+0.41}_{-0.48}, \tag{2}$$

where γ, ψ are roll and yaw respectively.

These models are acting as nonlinear filters and reflecting the peculiarities of human motion perception and dynamic properties of human vestibular system, quantify a motion sensation depending on kinematic parameters of aircraft motion and are suitable for effective use in motion cueing. Due to same essence of human motion perception regardless of angular degree of freedom, they have identical structure and represent a differential equation of the second order, input of which receives kinematic motion parameters, and output of which allows to assess a motion perception by a pilot.

The values of the differential thresholds of motion cue perception on flight simulator were experimentally determined along individual degrees of freedom (Table 2).

Table 2

Forecast time along individual degrees of freedom

Degree of freedom	Roll	Yaw
Differential perception threshold	2.5 degree/s ³	0.5 degree/s ³

The determination problem of maximum motion cue occurrence frequency along the vertical degree of freedom was solved for identification of motion cue occurrence peculiarities. The mathematical model of non-maneuverable aircraft was used in calculations. The control signal calculations were based on rudder driving actuator characteristics: sinusoidal control law was significantly distorted, and impulse law straight front was transformed into an inclined one, angle of which was determined by energy drive capabilities. The deflection speed of control column was accepted as maximum. The deflection amplitude was limited with the control column excursion, the ability to maintain the control law shape for a given control frequency and the allowable overload. To create limit flight modes, it was assumed that pilot did not have regulated piloting techniques.

Fig. 5 shows relative amplitudes of motion perception function ($\bar{A}_\Omega = \Omega/\Omega_c$) of the system «aircraft-ideal pilot» along the roll. (The condition for a motion cue perception is achievement of unit with relative amplitude of motion perception function: $\bar{A}_\Omega \geq 1$). Calculated roll rate, motion perception functions and control column turn angles are shown in Fig. 6. As can be seen from this figure, the maximum frequency of perceived motion cue along the roll is 0.6 Hz.

Thus, the minimum time interval between the appearances of perceived motion cues along roll is 1.7 s.

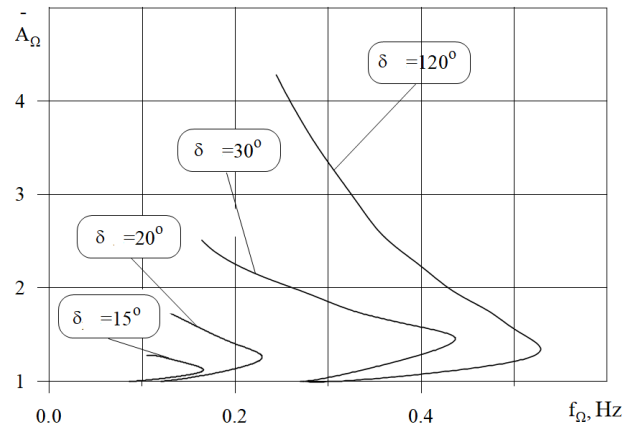

Fig. 5. Dependence of relative amplitude of motion perception function on motion cue frequency along the roll

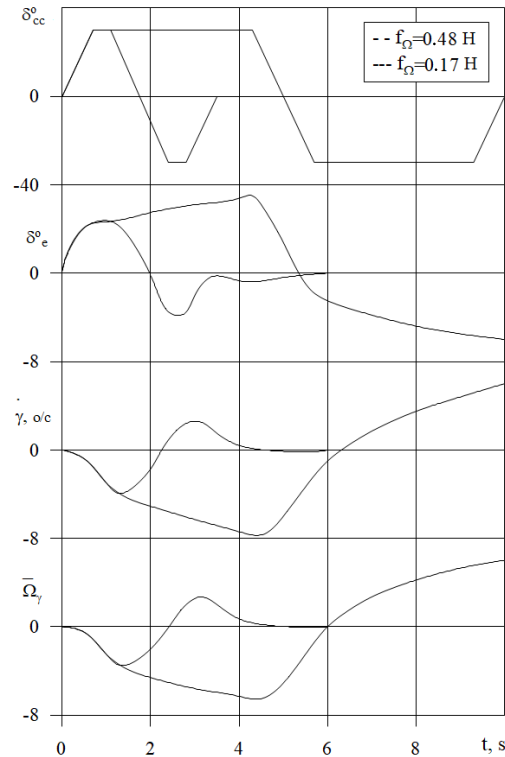

Fig. 6. Reaction of non-maneuverable aircraft model along the roll at different aileron deviations

There are dynamic (over 0.3 Hz) and static (up to 0.3 Hz) motion cues along the angular degrees of freedom, namely:

- dynamic motion cues along the roll and yaw;
- static motion cues along the longitudinal and lateral degrees of freedom;
- simulation of aircraft movement along pitch.

Conditions which serve as the basis for high-quality motion cueing may be formulated on the peculiarities of human motion perception:

- characteristics attributes of perceived motion cues: a beginning time, a direction, an intensity and a duration of perception should be simulated;
- nature of motion perception on flight simulator should be such as real (during motion cueing should be absent false motion cues);

- difference between a beginning time of motion perception on aircraft and flight simulator should be minimum and be within the requirements;
- direction of motion perception on flight simulator should correspond to real;
- intensity and duration of motion cues should be proportional to intensity and duration of motion cues occurring in actual flight.

Due to the finite speed of processes on flight simulators, motion cues have some time delays, which can worsen pilot’s activity on flight simulator. Due to limited constructive resources of flight simulator in comparison with aircraft resources, it is impossible to continuously monitor an aircraft motion perception function Ω_a and motion perception function on flight simulator Ω_{fs} has gaps and differs from an aircraft motion perception function Ω_a (Fig. 7).

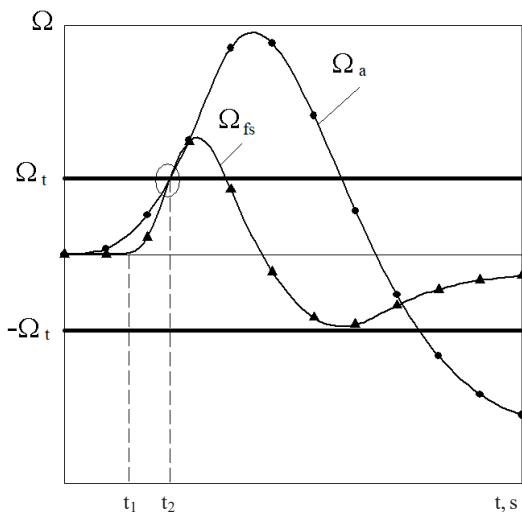

Fig. 7. Perception of motion cues on aircraft and flight simulator

To ensure a coincidence of a perception beginning time on a flight simulator and aircraft, an aircraft forecast motion perception function is calculated (predictive values of aircraft motion perception function at the time $t+\Delta\tau$):

$$\begin{aligned} \bar{\Omega}_{a\gamma} &= \Omega_{a\gamma} + \Delta\tau \dot{\Omega}_{a\gamma} + 0.5\tau^2 \ddot{\Omega}_{a\gamma}, \\ \bar{\Omega}_{a\psi} &= \Omega_{a\psi} + \Delta\tau \dot{\Omega}_{a\psi} + 0.5\tau^2 \ddot{\Omega}_{a\psi}. \end{aligned} \quad (3)$$

Forecast times on flight simulator of the An-74TK-200 aircraft along individual degrees of freedom are given in Table 3.

Table 3

Forecast time along individual degrees of freedom

Degree of freedom	Roll	Yaw
Forecast time	0.3 s	0.3 s

Realization of forecast time along roll on flight simulator shows (Fig. 8) very good results.

An aircraft motion perception function Ω_a begins to differ from zero at time $t=0$. At time t_1 , a forecast motion perception function of aircraft Ω_a reaches a threshold Ω_n value and motion cueing start on flight simulator. To coincide the times of motion perception beginning on aircraft and flight simulator (time t_2) a starting movement of flight simulator should be more intense than aircraft movement, and value of forecast time of aircraft motion perception function (with control signals of different intensity, creating motion cues in a range from the minimum that almost little different from perception threshold, to the maximum that can be created on this flight simulator) for a particular flight simulator and a specific aircraft (i. e., taking into account the dynamic characteristics of flight simulator and aircraft) for each degree of freedom $\Delta\tau=[\Delta\tau_x, \Delta\tau_y]^T$ is selected so that difference between motion perception on aircraft and flight simulator should be minimal and within current requirements.

Vector of derived predictive aircraft motion perception function $\bar{\Omega}_a = [\bar{\Omega}_{a\gamma}, \bar{\Omega}_{a\psi}]^T$ is calculated for determination of perceived motion intensity:

$$\begin{aligned} \bar{\Omega}_{a\gamma} &= \dot{\Omega}_{a\gamma} + \Delta\tau \ddot{\Omega}_{a\gamma}, \\ \bar{\Omega}_{a\psi} &= \dot{\Omega}_{a\psi} + \Delta\tau \ddot{\Omega}_{a\psi}. \end{aligned} \quad (4)$$

Methodologically, the motion cueing on flight simulator is very complex problem, which can be solved only with careful agreement of information about movement of aircraft and flight simulator. Due to presence of system factor – quality of motion cueing (which means degree of approximation of motion perception on flight simulator and aircraft) – the problem motion cueing should be formulated on basis of systematic approach.

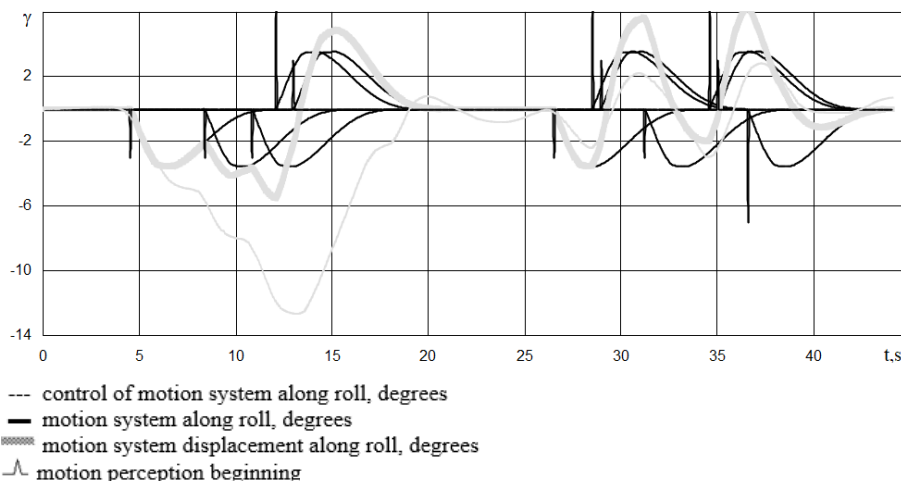

Fig. 8. Motion cueing along roll

Signs of motion perception function of aircraft Ω_a and flight simulator Ω_{fs} should coincide if modules of motion perception function of aircraft Ω_a and flight simulator Ω_{fs} are higher than the perception threshold Ω_t , and module of predictive motion perception function of aircraft $|\bar{\Omega}_a|$ has reached or exceeded the perception threshold Ω_t , and if modules of motion perception function of aircraft $|\bar{\Omega}_a|$ and flight simulator $|\bar{\Omega}_{fs}|$ are greater than the perception threshold Ω_t , and may not coincide when motion perception function of aircraft Ω_a is higher than the perception threshold Ω_t , and module of motion perception function of flight simulator Ω_{fs} lower than the perception threshold Ω_t :

$$\text{sign}\Omega_{fs} = \begin{cases} \text{sign}\Omega_a & \left| \bar{\Omega}_a \right| \geq \Omega_t, \left| \Omega_a \right| < \Omega_t, \left| \Omega_{fs} \right| < \Omega_t; \\ \left| \Omega_a \right| \geq \Omega_t, \left| \Omega_{fs} \right| \geq \Omega_t; \\ \pm \text{sign}\Omega_a & \left| \bar{\Omega}_a \right| \geq \Omega_t, \left| \Omega_a \right| \geq \Omega_t, \left| \Omega_{fs} \right| < \Omega_t, \end{cases} \quad (5)$$

where $\Omega_{fs} = [\Omega_{fs\gamma}, \Omega_{fs\psi}]^T$ is vector of motion perception function of flight simulator.

As assessment criterion of perceived motion cues it is natural to use the functionality $J = [J_\gamma, J_\psi]^T$ that evaluates the error of coincidence of motion cueing perception on aircraft and flight simulator:

$$J = \int_0^T \left| \Omega_a(t) - \Omega_{fs}[u(t)] \right| dt \left| \Omega_a(t) \right| \Omega_t, \quad (6)$$

where $u = [u_\gamma, u_\psi]^T$ is the vector of program signal, and reduce the problem of motion cueing to the synthesis of program signal that minimizes the functionality:

$$\begin{aligned} J(u) &= \min \Rightarrow u(t), \\ \Omega_{fs} &\rightarrow \Omega_a, \\ \text{sign}\Omega_{fs} &= \text{sign}\Omega_a, \\ |t_{fs} - t_a| &= \min < t_r, \end{aligned} \quad (7)$$

where t_a , t_{fs} are beginning time of motion perception on aircraft and flight simulator respectively; t_r is requirement difference between beginning time of motion perception on aircraft t_a and flight simulator t_{fs} .

Such results are explained by system approach principles of motion perception. They are differing from those known from the literature and from practical experience due to taking into account the peculiarities of human movement perception: character, direction, duration, intensity and time of motion perception.

Based on the system approach principles, the mathematical formulation of the solution to the problem of motion cueing along angular degrees of freedom on flight simulators of non-maneuvering aircraft is used.

The results obtained during the study *can be applied in practice* for motion cueing on flight simulator motion system.

Limitations of conducting research are motion system constructive resource that affects the results obtained.

The conditions of martial law in Ukraine have not influenced the conduct of the study and the results obtained through absence of electric power and air raid sirens in Kyiv.

Further research will be aimed at the development of effective methodology for motion cueing along separate angular degrees of freedom.

4. Conclusions

The proposed formulation of the problem of motion cueing along angular degrees of freedom shows the main directions of increasing of motion cue fidelity. These results are explained by system approach principles. The use of these results practically can bring success in motion cueing along angular degrees of freedom. Quantitative assessments of the results consist in that the character and direction of motion cues fully correspond to the real motion cues, the difference between the perception time of motion cues on airplane and simulator is minimal and within 150 ms according to requirements of Synthetic Training Device of Joint Aviation Administration, the duration and intensity of the motion cue perception on simulator are proportional duration and intensity of motion cue perception on airplane.

Conflict of interest

The authors declare that they have no conflict of interest in relation to this study, including financial, personal, authorship, or any other, that could affect the study and its results presented in this article.

Financing

The study was conducted without financial support.

Data availability

The manuscript has no associated data.

Use of artificial intelligence

The authors confirm that they did not use artificial intelligence technologies when creating the current work.

References

1. *Predvaritelnaia otsenka vlianiia podvizhnosti aviatrenazhera na protsess pilotirovaniia i analiz sposobov upravleniia dvizheniem otseka* (1970). Otchet NII/TcAGI, No. GR 015110-1, inv. No. 655. Moscow, 34.
2. Aleksandrov, V. V., Sadovnichii, V. A., Chugunov, O. D. (1986). *Matematicheskie problemy dinamicheskogo modelirovaniia poleta*. Moscow: MGU, 181.
3. Bussolari, S., Young, L., Lee, A. (1989). The use of vestibular models for design and evaluation of flight simulator motion. *Flight Simulation Technologies Conference and Exhibit*. Washington, 86–93. doi: <https://doi.org/10.2514/6.1989-3274>
4. Hall, J. R. (1989). *The Need for Platform Motion in Modern Piloted Flight Training Simulators*. Tech Memo FM 35. Royal Aerospace Establishment. Bedford, 16.
5. Heintzman, R. J. (1996). *Determination of Force Cueing Requirements for Tactical Combat Flight Training Devices*. SIMTEC, Inc., ASC-TR-97-5001, 153.
6. 14 CFR Part 60 (2016). NSP Consolidated Version, 639.
7. Davison, P. J. (2018). *Motion in Flight Simulators – A story of Evolution. Suite D, 6/F*. Ho Lee Commercial Building, 17.
8. Chesebrough, D. (2000). *The Link Flight Trainer*. Binghamton, 12.
9. Bürki-Cohen, J., Go, T. H. (2005). The Effect of Simulator Motion Cues on Initial Training of Airline Pilots. *AIAA Modeling and Simulation Technologies Conference*. AIAA-2005-6109. doi: <https://doi.org/10.2514/6.2005-6109>

10. Longbridge, T., Burki-Cohen, J., Go, T. (2001). Flight Simulator Fidelity Considerations for Total Airline Training and Evaluation. *AIAA Modeling and Simulation Technologies Conference. AIAA-2001-4425*. doi: <https://doi.org/10.2514/6.2001-4425>
11. White, A. D. (1994). *The Impact of Cue Fidelity on Pilot Behavior and Performance*. FDS Dept., Defence Research Agency. Bedford.

Volodymyr Kabanyachyi, Doctor of Technical Sciences, Department of Aircraft and Rocket Engineering, National Technical University of

Ukraine «Igor Sikorsky Kyiv Polytechnic Institute», Kyiv, Ukraine, ORCID: <https://orcid.org/0000-0003-0170-3923>

✉ **Beycan Ibrahimoglu**, Postgraduate Student, Department of Aircraft and Rocket Engineering, National Technical University of Ukraine «Igor Sikorsky Kyiv Polytechnic Institute», Kyiv, Ukraine, e-mail: beycanibrahimoglu@gmail.com, ORCID: <https://orcid.org/0009-0003-1368-0498>

✉ Corresponding author