

# DIGITALES ARCHIV

ZBW – Leibniz-Informationszentrum Wirtschaft  
ZBW – Leibniz Information Centre for Economics

Veselica, Rozana (Ed.); Dukic, Gordana (Ed.); Hammes, Khalid (Ed.)

## Conference Paper

Economic and social development : 36th International Scientific Conference on Economic and Social Development - "Building Resilient Society" : book of proceedings : Zagreb, 14-15 December 2018

## Provided in Cooperation with:

Varazdin Development and Entrepreneurship Agency

*Reference:* (2018). Economic and social development : 36th International Scientific Conference on Economic and Social Development - "Building Resilient Society" : book of proceedings : Zagreb, 14-15 December 2018. Varazdin, Croatia : Varazdin Development and Entrepreneurship Agency.

This Version is available at:

<http://hdl.handle.net/11159/2488>

## Kontakt/Contact

ZBW – Leibniz-Informationszentrum Wirtschaft/Leibniz Information Centre for Economics  
Düsternbrooker Weg 120  
24105 Kiel (Germany)  
E-Mail: [rights\[at\]zbw.eu](mailto:rights[at]zbw.eu)  
<https://www.zbw.eu/econis-archiv/>

## Standard-Nutzungsbedingungen:

Dieses Dokument darf zu eigenen wissenschaftlichen Zwecken und zum Privatgebrauch gespeichert und kopiert werden. Sie dürfen dieses Dokument nicht für öffentliche oder kommerzielle Zwecke vervielfältigen, öffentlich ausstellen, aufführen, vertreiben oder anderweitig nutzen. Sofern für das Dokument eine Open-Content-Lizenz verwendet wurde, so gelten abweichend von diesen Nutzungsbedingungen die in der Lizenz gewährten Nutzungsrechte.

<https://zbw.eu/econis-archiv/termsfuse>

## Terms of use:

*This document may be saved and copied for your personal and scholarly purposes. You are not to copy it for public or commercial purposes, to exhibit the document in public, to perform, distribute or otherwise use the document in public. If the document is made available under a Creative Commons Licence you may exercise further usage rights as specified in the licence.*

Varazdin Development and Entrepreneurship Agency  
in cooperation with  
University North  
Faculty of Management University of Warsaw  
Faculty of Law, Economics and Social Sciences Sale - Mohammed V University in Rabat



# Economic and Social Development

36<sup>th</sup> International Scientific Conference on Economic and Social Development –  
"Building Resilient Society"

## Book of Proceedings

Editors:

Rozana Veselica, Gordana Dukic, Khalid Hammes



ISSN 1849-7535

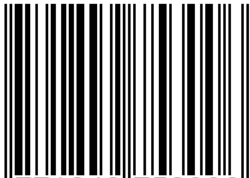

9 771849 753006 >

Zagreb, 14-15 December 2018

**Varazdin Development and Entrepreneurship Agency**  
in cooperation with  
**University North**  
**Faculty of Management University of Warsaw**  
**Faculty of Law, Economics and Social Sciences Sale - Mohammed V University in Rabat**

Editors:  
**Rozana Veselica, Gordana Dukic, Khalid Hammes**

**Economic and Social Development**  
36<sup>th</sup> International Scientific Conference on Economic and Social Development –  
"Building Resilient Society"

Supported by: **President of Croatia, Kolinda Grabar - Kitarovic**



**Book of Proceedings**

Zagreb, 14-15 December 2018

**Title** ■ Economic and Social Development (Book of Proceedings), 36<sup>th</sup> International Scientific Conference on Economic and Social Development – "Building Resilient Society "

**Editors** ■ Rozana Veselica, Gordana Dukic, Khalid Hammes

**Scientific Committee / Programski Odbor** ■ Marijan Cingula, University of Zagreb, Croatia (President); Sandra Raquel Alves - University of Aveiro, Portugal; Ayuba A. Aminu, University of Maiduguri, Maiduguri, Nigeria; Anona Armstrong, Victoria University, Australia; Gouri Sankar Bandyopadhyay, The University of Burdwan, Rajbati Bardhaman, India; Haimanti Banerji, Indian Institute of Technology, Kharagpur, India; Alla Bobyleva, The Lomonosov Moscow State University, Russia; Leonid K. Bobrov, State University of Economics and Management, Novosibirsk, Russia; Rado Bohinc, University of Ljubljana, Slovenia; Elisabeth de Jesus Oliveira Brito - University of Aveiro, Portugal; Zeki Atıl Bulut, Dokuz Eylül University, Turkey; Adnan Celik, Selcuk University - Konya, Turkey; Angelo Maia Cister, Federal University of Rio de Janeiro, Brasil; Mirela Cristea, University of Craiova, Romania; Sreten Cuzovic, University of Nis, Serbia; Oguz Demir, Istanbul Commerce University, Turkey; T.S. Devaraja, University of Mysore, India; Onur Dogan, Dokuz Eylül University, Turkey; Darko Dukic, University of Osijek, Croatia; Gordana Dukic, University of Osijek, Croatia; Alba Dumi, Vlora University, Vlora, Albania; Ksenija Dumcic, University of Zagreb, Croatia; Galina Pavlovna Gagarinskaya, Samara State University, Russia; Fran Galetic, Zagreb University, Croatia; Mirjana Gligoric, Faculty of Economics, Belgrade University, Serbia; Mehmet Emre Gorgulu, Afyon Kocatepe University, Turkey; Liudmila Guzikova, Peter the Great Saint-Petersburg Polytechnic University, Russia; Anica Hunjet, University North, Koprivnica, Croatia; Oxana Ivanova, Ulyanovsk State University, Ulyanovsk, Russia; Irena Jankovic, Faculty of Economics, Belgrade University, Serbia; Lara Jelenc, University of Rijeka, Croatia; Myrl Jones, Radford University, USA; Gorazd Justinek, Graduate School of Government and European Studies, Slovenia; Hacer Simay Karaalp, Pamukkale University, Turkey; Grzegorz Karasiewicz, University of Warsaw, Poland; Dafna Kariv, The College of Management Academic Studies, Rishon Le Zion, Israel; Salih Katircioglu, Eastern Mediterranean University, Northern Cyprus, Turkey; Hilal Yildirim Keser, Uludag University, Bursa, Turkey; Martina Dragija Kostic, Sophia Khalimova, Institute of Economics and Industrial Engineering of Siberian Branch of Russian Academy of Science, Novosibirsk, Russia; Marina Klacmer Calopa, University of Zagreb, Croatia; Vladimir Kovsca, University of Zagreb, Croatia; Goran Kozina, University North, Koprivnica, Croatia; Dzenan Kulovic, University of Zenica, Bosnia and Herzegovina; Robert Lewis, Les Roches Gruyère University of Applied Sciences, Bulle, Switzerland; Ladislav Lukas, Univ. of West Bohemia, Faculty of Economics, Czech Republic; Pascal Marty, University of La Rochelle, France; Vaidotas Matutis, Vilnius University, Lithuania; Marjana Merkac Skok, GEA College of Entrepreneurship, Ljubljana, Slovenia; Daniel Francois Meyer, North West University, South Africa; Marin Milkovic, Rector, University North, Koprivnica, Croatia; Zlatko Nedelko, University of Maribor, Slovenia; Gratiela Georgiana Noja, West University of Timisoara, Romania; Zsuzsanna Novak, Corvinus University of Budapest, Hungary; Alojzy Z. Nowak, University of Warsaw, Poland; Tomasz Ochowski, University of Warsaw, Poland; Mislav Ante Omazic, University of Zagreb, Croatia; Vera Palea, Università degli Studi di Torino, Italy; Dusko Pavlovic, President DIU Libertas International University, Zagreb, Croatia; Igor Pihir – University of Zagreb, Croatia; Dinko Primorac, University North, Koprivnica, Croatia; Zeljka Primorac, University of Split, Croatia; Mirosław Przygoda, University of Warsaw, Poland; Nicholas Recker, Metropolitan State University of Denver, USA; Kerry Redican, Virginia Tech, Blacksburg, USA; Humberto Ribeiro, University of Aveiro, Portugal; Robert Rybnicek, University of Graz, Austria; Joanna Stawska, University of Lodz, Poland; Elzbieta Szymanska, Bialystok University of Technology, Poland; Katarzyna Szymanska, The State Higher School of Vocational Education in Ciechanow, Poland; Jan Turyna, University of Warsaw, Poland; Ilaria Tutore, University of Naples Parthenope, Italy; Claudia Miranda Veloso - University of Aveiro, Portugal; Rebeka Danijela Vlahov, University of Zagreb; Ilko Vrankic, University of Zagreb, Croatia; Stanislaw Walukiewicz, Bialystok University of Technology, Poland; Thomas Will, Agnes Scott College, USA; Li Yongqiang, Victoria University, Australia; Peter Zabielskis, University of Macau, China; Tao Zeng, Wilfrid Laurier University, Waterloo, Canada; Snezana Zivkovic, University of Nis, Serbia.

**Review Committee / Recenzentski Odbor** ■ Marina Klacmer Calopa (President); Ana Aleksic; Sandra Raquel Alves; Ayuba Aminu; Mihovil Andjelinovic; Josip Americ; Lidija Bagaric; Tomislav Bakovic; Sanja Blazevic; Leonid Bobrov; Ruzica Brečić; Anita Ceh Casni; Mirela Cristea; Oguz Demir; Jasmina Dvorski; Stjepan Dvorski; Robert Fabac; Ivica Filipovic; Sinisa Franjic; Fran Galetic; Mirjana Gligoric; Tomislav Globan; Anita Goltnik Urnaut; Tomislav Herceg; Irena Jankovic; Emina Jerkovic; Dafna Kariv; Oliver Kesar; Hilal Yildirim Keser; Tatjana Kovac; Vladimir Kovsca; Angelo Maia Cister; Katarina Marosevic; Vaidotas Matutis; Marjana Merkac Skok; Josip Mikulic; Ljubica Milanovic Glavan; Daniel Francois Meyer; Natanya Meyer; Guenter Mueller; Ivana Nacinovic Braje; Zlatko Nedelko; Gratiela Georgiana Noja; Zsuzsanna Novak; Alka Obadic; Claudia Ogorean; Igor Pihir; Najla Podrug; Vojko Potocan; Dinko Primorac; Zeljka Primorac; Sanda Renko; Humberto Ribeiro; Vlasta Roska; Souhaila Said; Armando Javier Sanchez Diaz; Tomislav Sekur; Lorena Skufflic; Mirko Smoljic; Petar Soric; Mario Spremic; Matjaz Stor; Tomasz Studzieniecki; Lejla Tijanic; Daniel Tomic; Boris Tusek; Rebeka Daniela Vlahov; Ilko Vrankic; Thomas Will; Zoran Wittine; Tao Zeng; Grzegorz Zimon; Snezana Zivkovic; Berislav Zmuk.

**Organizing Committee / Organizacijski Odbor** ■ Sime Vucetic (President); Domagoj Cingula; Marina Klacmer Calopa; Spomenko Kesina; Erlino Koscak; Goran Pavelin; Mirosław Przygoda; Michael Stefulj; Rebeka Danijela Vlahov.

**Publishing Editor** ■ Domagoj Cingula

**Publisher** ■ **Design** ■ **Print** ■ Varazdin Development and Entrepreneurship Agency, Varazdin, Croatia / University North, Koprivnica, Croatia / Faculty of Management University of Warsaw, Warsaw, Poland / Faculty of Law, Economics and Social Sciences Sale - Mohammed V University in Rabat, Morocco

**Printing** ■ Online Edition

**ISSN 1849-7535**

The Book is open access and double-blind peer reviewed.

Our past Books are indexed and abstracted by ProQuest, EconBIZ, CPCI (WoS) and EconLit databases and available for download in a PDF format from the Economic and Social Development Conference website: <http://www.esd-conference.com>

© 2018 Varazdin Development and Entrepreneurship Agency, Varazdin, Croatia; University North, Koprivnica, Croatia; Faculty of Management University of Warsaw, Warsaw, Poland; Faculty of Law, Economics and Social Sciences Sale - Mohammed V University in Rabat, Morocco. All rights reserved. Authors are responsible for the linguistic and technical accuracy of their contributions. Authors keep their copyrights for further publishing.

## **CONTENTS**

### **OLIVE OIL FOR HEALTHY CONSUMERS AND WEALTHY ECONOMIES: THE CASE OF SELECTED EUROPEAN UNION COUNTRIES SINCE ACCESSION ..... 1**

Humberto Ribeiro, Sandra Raquel Alves, Vlasta Roska, Carla Lousas

### **ENTERPRISE IN TURBULENT ENVIRONMENT – INFLUENCE OF ENVIRONMENTAL POLICY IN POLAND..... 19**

Aleksandra Ferens

### **FORECASTING THE DEVELOPMENT INDICATORS OF MECHANICAL ENGINEERING IN RUSSIA..... 28**

Yuliya V. Razvadovskaya, Anton A. Afanasyev, Inna K. Shevchenko, Anna V. Khanina, Ekaterina V. Kaplyuk, Anna A. Marchenko

### **EFFECTIVE WAYS TO COMMUNICATE ENTREPRENEURSHIP CONCEPTS TO MOROCCAN MILLENIALS..... 37**

Houda Jorio, Samira Kasmi, Mustapha Machrafi

### **CORRELATION ANALYSIS OF SEARCHING TREND OF THE TERM VIRTUAL REALITY IN SELECTED SEGMENTS IN CONDITIONS OF THE SLOVAK MARKET ..... 56**

Radovan Bacik, Ľudovít Nastisin, Richard Fedorko

### **STATE AID IN THE EU AGRICULTURE ..... 61**

Barbara Wieliczko

### **TWO SCENARIOS OF FINANCIAL ACTIVATION OF THE GUARANTEED MINIMUM INCOME RECIPIENTS, IN TERMS OF REDUCING POVERTY IN ROMANIA..... 69**

Cristina Stroe, Codruta Dragoiu, Andreea Cambir

### **AUDIT OF PUBLIC PROCUREMENT EFFORTS AND REVIEW OF RECOMMENDATIONS..... 79**

Dubravka Mahacek, Aleksandar Vcev, Damir Sebo

### **CHATBOT EVALUATION METRICS: REVIEW PAPER..... 89**

Dijana Peras

### **“GREEN” MANAGERIAL DELEGATION AND ENVIRONMENTAL CORPORATE SOCIAL RESPONSIBILITY IN DIFFERENT MARKET STRUCTURES ..... 98**

Domenico Buccella, Michal Wojna

### **THE PROBLEMATICS OF USING MOBILE DEVICES FOR E-COMMERCE IN THE V4 COUNTRIES ..... 109**

Radovan Bacik, Richard Fedorko, Maria Olearova

### **CORPORATE GOVERNANCE IN INDIA: AN ANALYSIS..... 119**

Meghna Thapar

<b>ANALYSIS OF INVESTOR BEHAVIOR: MARKET FEELING AND HERDING BEHAVIOR IN THE PORTUGUESE STOCK MARKET.....</b>	<b>124</b>
Gabriela Leite, Humberto Ribeiro, Carlos Machado-Santos, Amelia Ferreira da Silva, Jose Manuel Pereira	
<b>ONLINE SHOPS AND ONLINE SHOPPING FROM THE POINT OF VIEW OF THE SLOVAK CONSUMER.....</b>	<b>134</b>
Jaroslava Gburova, Richard Fedorko	
<b>GAME MECHANICS DIFFERENCES FOR KOSOVANS SOCIAL MEDIA PURCHASERS.....</b>	<b>141</b>
Fortesa Haziri, Miloslava Chovancova	
<b>SUPPRESSION OF CORRUPTION AND SPECIAL INVESTIGATION TECHNIQUES IN CROATIA WITH REFERENCE TO STANDARDS OF EUROPEAN COURT OF HUMAN RIGHTS.....</b>	<b>150</b>
Barbara Herceg Paksic	
<b>GEO-ECONOMICS TO FIGHT AGAINST HUNGER IN AFRICA: WHAT ROLE FOR EMERGING COUNTRIES? .....</b>	<b>160</b>
Abdelhamid Nechad, Mohammed Ezznati, Taoufik Daghri	
<b>THE USE OF ICT POTENTIAL IN V4 COUNTRIES .....</b>	<b>169</b>
Joanna Kos-Labedowicz	
<b>SPACE-TIME CLASSIFICATION OF THE COUNTRIES OF THE EUROPEAN CONTINENT IN THE CONTEXT OF THE DEVELOPMENT OF GLOBALIZATION .....</b>	<b>179</b>
Monika Hadas-Dyduch	
<b>WHY REVENUES FROM PAYROLL TAXES DO NOT FOLLOW TRENDS IN TAXATION OF INCOME OF CORPORATIONS?.....</b>	<b>190</b>
Andrzej Karpowicz	
<b>SHADOW CASHING SCHEMES IN THE CONTEXT OF JUDICIAL EXPERTISE</b>	<b>203</b>
Evgenia V. Baturina, Aleksandr N. Litvinenko, Liudmila A. Guzikova	
<b>CORRELATION BETWEEN MOBILE GAMES MARKET AND THE DEVELOPMENT OF VIDEO GAME MARKET IN CHINA.....</b>	<b>208</b>
Josko Lozic, Marin Milkovic, Ines Lozic	
<b>THE PRINCIPLE AND THE DEVELOPMENT OF VAT GAP IN SELECTED EU COUNTRIES .....</b>	<b>217</b>
Jaroslav Korecko, Alzbeta Suhanyiova	
<b>THE LIABILITY OF LEGAL ENTITIES FOR CRIMINAL ACTS IN CROATIAN COURT PRACTICE.....</b>	<b>225</b>
Nina Misic Radanovic	

<b>A MULTIDIMENSIONAL APPROACH TO VALUE MANAGEMENT IN A SMALL AND MEDIUM-SIZED ENTERPRISE.....</b>	<b>235</b>
Ewa Mackowiak, Iwona Kumor	
<b>HAPPINESS AS A RESILIENCE RESOURCE FOR THE SOCIAL REPRODUCTION OF HUMAN CAPITAL IN THE PRIVATE SPHERE.....</b>	<b>241</b>
Claudiu Coman	
<b>PRICE COMPETITION AND ENTRY UNDER CORPORATE SOCIAL RESPONSIBILITY PRODUCT DIFFERENTIATION .....</b>	<b>248</b>
Michal Wojna, Domenico Buccella	
<b>ANALYSIS OF THE EFFECTS OF APPLYING THE NEW IFRS 16 LEASES ON THE FINANCIAL STATEMENTS.....</b>	<b>255</b>
Mirjana Hladika, Ivana Valenta	
<b>FACTORS EFFECTING MARKET ACTIVITIES THAT LEADS TO INVESTOR'S OVERCONFIDENCE: PAKISTAN STOCK EXCHANGE CASE.....</b>	<b>264</b>
Fareeha Javed Qureshi, Murat Ertugrul	
<b>HOBBY CULTURE AS A SOURCE OF ENTERPRENEURSHIP – INNOVATION AND RISK MANAGEMENT .....</b>	<b>273</b>
Niko Komljenovic, Nenad Rancic, Ozren Pilipovic	
<b>NON-FINANCIAL INFORMATION DISCLOSURES AND CSR REPORTING VERSUS THE INFORMATION ASYMMETRY PROBLEM.....</b>	<b>282</b>
Ewelina Papaj-Wlislocka	
<b>TECHNOLOGY, ORGANISATION AND STRETEGY AS THE TOOL TO OVERCOME NEGATIVE EXTERNALITIES.....</b>	<b>290</b>
Mario Lesina, Lovorka Gotal Dmitrovic, Marko Stojic	
<b>DISPARITIES IN DEVELOPMENT BASED ON TAXONOMIC RESEARCH – THE CASE OF SELECTED LATIN AMERICAN COUNTRIES .....</b>	<b>300</b>
Iwona Pawlas	
<b>SETTING BID PRICES IN CONSTRUCTION: CASE STUDY OF FORMWORKS. 310</b>	
Petr Aigel, Miloslav Vyskala, Patrik Janas	
<b>COMPARING CUSTOMER MANAGEMENT OF THE NEW CUSTOMER GENERATION USING DESKTOP VERSUS SMARTPHONE IN E-COMMERCE CONDITIONS.....</b>	<b>317</b>
Radovan Bacik, Jakub Horvath, Richard Fedorko	
<b>ECONOMIC ASPECT OF COUNTERING THE FINANCING OF TERRORISM ...</b>	<b>324</b>
Aleksandr N. Litvinenko, Liudmila A. Guzikova	
<b>YOUTH AND THE LABOUR MARKETS IN THE EUROPEAN UNION .....</b>	<b>330</b>
Roman Klimko, Eva Rievajova	

<b>THE RELEVANCE AND DISTRIBUTION OF CERTIFIED B CORPORATIONS IN THE EUROPEAN UNION ECONOMY .....</b>	<b>337</b>
Sabina Lacmanovic, Dario Milec	
<b>THE IMPACT OF SHAREHOLDER PERCEPTION OF CAPITAL ON OWNERSHIP STRUCTURE IN THE CONTEXT OF SHAREHOLDER DEMOCRACY - CASE OF THE CROATIAN CAPITAL MARKET.....</b>	<b>347</b>
Ante Samodol, Sonja Brlecic Valcic	
<b>THE CHARACTERISTICS OF MERGERS AND ACQUISITIONS AND THEIR IMPACT ON PERFORMANCE IN EMERGING COUNTRIES: A SAUDI ARABIAN STUDY .....</b>	<b>357</b>
Sara Khotbi	
<b>PUBLIC CONSULTATIONS IN THE LIGHT OF CO-MANAGEMENT IN LOCAL GOVERNMENT .....</b>	<b>366</b>
Agnieszka Smalec, Marzena Wanagos	
<b>POTENTIAL OF CROWDFUNDING AS A FINANCIAL AND MARKETING INSTRUMENT IN THE REPUBLIC OF CROATIA.....</b>	<b>376</b>
Jadranka Ivankovic, Diana Plantic Tadic, Matea Fiser	
<b>INVESTIGATING CONSUMERS' BRANDS CONNECTION ON FACEBOOK .....</b>	<b>386</b>
Ivana Bilic, Milena Jelic Dzepina, Ana Cuic Tankovic	
<b>CLASSIFICATION OF R&amp;D ACTIVITY COSTS IN FINANCIAL ACCOUNTING</b>	<b>395</b>
Anna Dyhdalewicz	
<b>AN ANALYSIS OF THE LEVEL OF INTERNET-BASED INFORMATION PROCESSING IN THE USA AGAINST A BACKGROUND OF GLOBALIZATION .....</b>	<b>405</b>
Anna Janiga-Cmiel	
<b>THE POLITICAL AND ECONOMIC INTEGRATION OF LATIN AMERICA.....</b>	<b>410</b>
Miroslaw Przygoda	
<b>INFLUENCE ON DECISION-MAKING PROCESS FOR MOBILE MODELS AND PHONE TARIFF OPTIONS: CASE OF CHILDREN POPULATION.....</b>	<b>419</b>
Diana Plantic Tadic, Jadranka Ivankovic, Zrinka Mrkonjic	
<b>THE DECISION-MAKING ON INVESTMENT IN INDUSTRIAL ENTERPRISES – CASE STUDY.....</b>	<b>428</b>
Eva Malichova	
<b>STAKEHOLDER COLLABORATION: IMPLICATIONS FOR IMPROVING TOURIST DESTINATION MARKETING ACTIVITIES.....</b>	<b>436</b>
Marina Perisic Prodan	



<b>THE LEGAL ENVIRONMENT OF BUSINESS – REMEDIAL PROCEEDINGS IN CASE OF INSOLVENCY OF THE ENTERPRISE IN POLAND (SELECTED ISSUES)</b> .....	<b>445</b>
Monika Smusz - Kulesza	
<b>THE IMPACT OF WRITTEN CORRESPONDENCE ON BUILDING CUSTOMER RELATIONSHIP</b> .....	<b>454</b>
Izabela Ostrowska, Grazyna Rosa, Kamila Slupinska, Leszek Gracz	
<b>FIGHT AGAINST DOMESTIC VIOLENCE IN REPUBLIC OF CROATIA AND THE REPUBLIC OF SERBIA</b> .....	<b>464</b>
Vanda Bozic, Zeljko Nikac	
<b>EXAMINING THE EFFECTS OF TRAVEL CONSTRAINTS, TOURIST SATISFACTION AND WEBSITE IMAGE ON TOURIST LOYALTY IN DEVELOPING COUNTRIES CONTEXT</b> .....	<b>478</b>
Samar Rahi	
<b>THE DEVELOPMENT OF TRADE WITH WHEAT AT THE GLOBAL LEVEL</b> ....	<b>488</b>
Dragos Ion Smedescu, Alexandru Fintineru, Valentina Constanta Tudor, Cosmina Carbarau, Beatris Vasile-Tudor	
<b>THE VIRTUAL PRODUCTION LINE AS A MODEL FOR A CREATIVE LABOUR ANALYSIS</b> .....	<b>496</b>
Stanislaw Walukiewicz	
<b>POST-FORDISM AS A SOCIO-ECONOMIC CHANGE IN “TRANSITION” SOCIETIES</b> .....	<b>508</b>
Wieslaw Tadeusz Poplawski	
<b>SIMULATION OF THE INTEREST ON SAVINGS IMPACT ON THE CONSTRUCTION COMPANY VALUE DURING THE ECONOMIC CRISIS PERIOD</b> .....	<b>520</b>
Katerina Bozikova, Tomas Hanak	
<b>EFFECTIVENESS OF THE REVIEW OF PUBLIC PROCUREMENTS IN SELECTED COUNTRY</b> .....	<b>529</b>
Veronika Linhartova, Aneta Machackova	
<b>WOMEN IN MANAGEMENT - RESEARCH IN REPUBLIC OF CROATIA</b> .....	<b>539</b>
Igor Klopotan, Vesna Sesar, Ivana Martincevic	
<b>QUALITY IN MANAGING A HOTEL ON THE EXAMPLE OF GDYNIA</b> .....	<b>550</b>
Marzena Wanagos, Izabela Grajek-Czabajnska	
<b>COOPERATION OF ENTITIES IN THE MARKET OF REGIONAL TOURIST PRODUCTS</b> .....	<b>559</b>
Marzena Wanagos, Barbara Marciszewska	

<b>EVALUATION OF EU GRANT SCHEME USING WEBSITE PERFORMANCE MEASURES.....</b>	<b>567</b>
Lukasz Konopielko, Jacek Wytrebowicz	
<b>WOMEN IN THE SLOVAK IT SECTOR: FROM EDUCATION TO LABOR MARKET .....</b>	<b>573</b>
Peter Psenak, Urban Kovac, Jan Kacer, Miroslava Skypalova	
<b>MODELING ECONOMIC IMPACT OF NUCLEAR POWER PLANT FOR POLAND .....</b>	<b>582</b>
Mariusz Plich, Lukasz Konopielko	
<b>THEORETICAL POSSIBILITIES FOR CREATION OF ERASMUS+ PROGRAMME FOR NAVAL STUDIES AT THE UNIVERSITY OF SPLIT .....</b>	<b>590</b>
Goran Pavelin	
<b>PROTECTION OF INTELLECTUAL PROPERTY RIGHT IN POLAND .....</b>	<b>601</b>
Dominika Bochaczyk-Kupka	
<b>CUSTOMERS` REACTION TO UNETHICAL COMPANIES` BEHAVIOUR – COMPARING WEST VERSUS EAST EUROPE.....</b>	<b>605</b>
Valeryia Chouhun, Raquel Meneses, Humberto Ribeiro	
<b>FACTORS OF COMPETITIVENESS OF THE EUROPEAN MARKETS TO SUPPORT BUSINESS DECISION MAKING .....</b>	<b>620</b>
Laura Juznik Rotar	
<b>THE EFFECT OF SYSTEMIC STRESS IN THE UNITED STATES ON BILATERAL EXPORTS .....</b>	<b>628</b>
Dejan Romih, Peter Mikek, Alenka Kavkler, Silvo Dajcman	
<b>RETHINKING THE NEOLIBERAL PRESCRIPTIONS OF STATE-BUILDING: THE CASE OF BOSNIA AND HERZEGOVINA .....</b>	<b>636</b>
Bora Besgul, Melek Aylin Ozoflu	
<b>IMPACT OF UNIVERSITY DEGREE ON THE LABOR MARKET IN SLOVAKIA .....</b>	<b>644</b>
Peter Paenak, Urban Kovac, Jan Kacer, Miroslava Skypalova	
<b>WEALTH OR HAPPINESS OF THE EUROPEAN UNION– THE DILEMMA OF THE NORMATIVE ECONOMICS .....</b>	<b>653</b>
Tomasz Studzieniecki	
<b>SUSTAINABLE DEVELOPMENT OF AGRICULTURAL PRODUCTION IN BALTIC STATES.....</b>	<b>661</b>
Zofia Koloszko-Chomentowska	
<b>PROFIT AND ITS CORRELATED RISK APPEARING WHILE INVESTING IN 2008-2018.....</b>	<b>667</b>
Rafal Parvi	

<b>POTENTIAL CONSEQUENCES OF WORKING AND STUDYING TOURISM AND HOSPITALITY: THE CASE OF STUDENTS' BURNOUT.....</b>	<b>674</b>
Aleksandra Grobelna, Anna Tokarz-Kocik	
<b>CAN ORGANIZATIONAL CULTURE PREDICT DEVIANCE AT WORK: EXPLORING THE CAUSE EFFECT RELATION.....</b>	<b>686</b>
Ana Aleksic, Ivana Nacinovic Braje, Sanda Rasic Jelavic, Lovorka Galetic	
<b>CREATIVE TOURISM AND RURAL DEVELOPMENT IN CROATIA .....</b>	<b>694</b>
Barbara Franic, Danijela Grubisic	
<b>ANALYSIS OF ROAD FREIGHT MARKET IN CROATIA.....</b>	<b>699</b>
Dora Naletina	
<b>THE ANALYSIS OF COMPANIES OF THE FUEL SECTOR BASED ON THE EXAMPLE OF COMPANIES QUOTED ON THE WARSAW STOCK EXCHANGE IN POLAND AND THEIR FAIR VALUE BETWEEN 2008-2018 .....</b>	<b>710</b>
Rafal Parvi	
<b>CONSUMER POLICY AND ITS TOOLS IN CONDITIONS OF THE SLOVAK REPUBLIC .....</b>	<b>718</b>
Daniel Halaj, Zuzana Dobsinska	
<b>THE CONVERGENCE OF AGRICULTURAL GROWTH.....</b>	<b>725</b>
Cezary Klimkowski	
<b>IMPLEMENTATION OF FLEXICURITY THROUGH CORPORATE SOCIAL RESPONSIBILITY .....</b>	<b>732</b>
Kristina Afric Rakitovac, Marija Buselic	
<b>COUNTRY OF ORIGIN IN FASHION INDUSTRY – A LITERATURE REVIEW ..</b>	<b>741</b>
Paula Gargoles Saes, Lana Lovrencic Butkovic, Alica Grilec	
<b>MARKETING INNOVATIONS IN POLISH SMALL AND MEDIUM ENTERPRISES .....</b>	<b>749</b>
Paula Pypłacz, Katarzyna Liczmanska – Kopcewicz, Katarzyna Mizera	
<b>FORECASTING CORRECTNESS OF INCURRING CREDIT WITH THE AID OF E.I. ALTMAN'S, J. GAJDKA'S AND D. STOS'S DISCRIMINANT ANALYSIS MODELS ON THE EXAMPLE OF 200 STUDIED COMPANIES FROM OPOLE AND POMORSKIE PROVINCES WITHIN 2010-2018 .....</b>	<b>758</b>
Rafal Parvi	
<b>BUSINESS INTELLIGENCE SYSTEM FOR MANAGING NATURAL GAS CONSUMPTION OF PUBLIC BUILDINGS .....</b>	<b>769</b>
Zlatko Tonkovic, Sasa Mitrovic, Marijana Zekic-Susac	
<b>CRITICAL ANALYSIS OF THE MEASUREMENT OF POVERTY: THE CASE OF EMERGING COUNTRIES .....</b>	<b>779</b>
Abdelhamid Nechad	

<b>EU INTRA-MOBILITY CAPACITY OF RESILIENCE.....</b>	<b>791</b>
Solange Maslowski	
<b>A COST ANALYSIS OF ALTERNATIVE THERAPEUTIC OPTIONS FOR CHRONIC KIDNEY DISEASE: A CASE STUDY .....</b>	<b>798</b>
Sara Pinto da Silva, Anabela Martins Silva, Amelia Ferreira da Silva, Humberto Ribeiro	
<b>PRICE AS THE STRONGEST MARKETING MIX TOOL IN THE BUYING PROCESS FROM A CONSUMER PERSPECTIVE .....</b>	<b>807</b>
Jaroslava Gburova, Radovan Bacik	
<b>GENDER PAY GAP IN THE ICT SECTOR IN POLAND IN 2010-2016.....</b>	<b>813</b>
Agata Gomolka	
<b>THE SYMBIOTIC RELATIONSHIP BETWEEN STARTUPS AND INCUBATORS</b>	<b>823</b>
Joao Sousa, Raquel Meneses, Humberto Ribeiro, Sandra Raquel Alves	
<b>MAINTAINING UNION REGULATIONS IN THE FORM OF SECTOR EXCLUSIONS WITH THE DETERMINANT OF THE DEVELOPMENT OF COMPETITIVENESS OF THE EUROPEAN AND EUROPE AUTOMOTIVE MARKET .....</b>	<b>835</b>
Wojciech Lewicki	
<b>THE IMPACT OF NEW TECHNOLOGY ADOPTATION IN BUSSINES .....</b>	<b>842</b>
Ivana Martincevic, Goran Kozina	

# **OLIVE OIL FOR HEALTHY CONSUMERS AND WEALTHY ECONOMIES: THE CASE OF SELECTED EUROPEAN UNION COUNTRIES SINCE ACCESSION**

**Humberto Ribeiro**

*GOVCOPP, ESTGA, University of Aveiro, Portugal*  
*hnr@ua.pt*

**Sandra Raquel Alves**

*CIC.DIGITAL, ESTG, Polytechnic Institute of Leiria, Portugal*  
*raquel.alves@ipleiria.pt*

**Vlasta Roska**

*University North, Koprivnica, Croatia*  
*vlasta.roska@unin.hr*

**Carla Lousas**

*ESTG, Polytechnic Institute of Bragança, Portugal*  
*carlalousas@gmail.com*

## **ABSTRACT**

*Since the dawn of the civilisations that olive has been playing a critical role on both the society and the economy. Indeed, one can argue that olive, and olive oil, were as critical as they shaped a form of culture, a seminal pillar that supported the Mediterranean civilisations and that has since then spread worldwide, influencing others. Taking into consideration this framework, the research presented in this paper is focused on the examination of the main trends on olive and olive oil in the Iberian Peninsula, from production to retail and consumption, by analysing several datasets covering recent decades. Ultimately, this research intends to examine whether olive oil production is effectively thriving in spite of the sector efforts, as the challenges being faced cannot be disregarded as well. In terms of findings for more recent years, it was possible to conclude that despite the increasing recognition of the benefits of olive and olive oil by the society, and despite the increase in olive production, the consumption of olive oil has been decreasing internally, being replaced by increases in exports. This is most probably due to the economic conditions that have deteriorated due to the 2008's financial crisis, which, together with an increase in olive oil prices, has prevented a considerable portion of the population to have financial conditions to access to the consumption of such an important component of the Mediterranean diet.*

**Keywords:** *Olive and Olive Oil, Production, Consumption and Retailing, Iberian Peninsula, European Union Accession*

## **1. INTRODUCTION**

For millennia that olive oil has been supporting the development of a pan-Mediterranean way of living. From gastronomic to religious use, to body care and healthcare even, olive oil is no longer an exclusive from Mediterranean countries as it is increasingly renowned worldwide in recognition to its qualities. Despite the benefits of olive and olive oil, its production is complex and defying, being furthermore subject to the nature caprices, as any generic agricultural good. Considering this complexity, the research examined here is focused on the examination of the main trends on olive and olive oil in the Iberian Peninsula, from production to retail consumption. The production of olive oil is sensitive to many factors, starting with the fate of the olive harvesting seasons.

In broad terms, it is known that production depends on many factors, being some of the most important, the olive production level, as endogenous, but also exogenous factors, such as the economic and social levels. Having this reality into consideration, in this paper the factors that possibly influence the olive oil production in recent decades are examined, with particular emphasis on more recent years, in Portugal and Spain. To achieve this goal, several agricultural and atmospheric conditions that relate with production, together with socio-economic factors that can be related to production, are going to be considered, observed, and examined. It is also important to highlight the importance of consuming trends to the olive oil production. This strand of analysis links also to corporate strategies designed to possibly attract more customers. This includes exploratory Corporate Social Responsibility and Social Media Marketing strategies and practices which are being used in the olive oil markets by major market players. Nevertheless, there is always the question to assess whether such strategic positioning is effectively influencing the public, boosting consumption and driving therefore olive oil production. The reality is that olive oil faces not only complexity, but also concrete and hard challenges. They can be severe to the point that such challenges related to issues such as olive oil quality and consumption conditions. Indirectly, this research relates to such conditions by the means of olive oil production as a proxy. Therefore, the research considers a comprehensive analysis, combining several factors, from olive oil production to consumption. The production conditions of olive and olive oil are considered to be the driving proxy that leads everything. Being true that olive oil consumption influences olive oil production, the opposite is true as well. Nevertheless, this reverse axiom is a stronger assumption, as the amount that is effectively possible to produce from each harvesting season is going to be determinant in the short and medium term, namely for the quality and prices that will determine the final consumption conditions. Ultimately, this research intends to examine whether olive oil production is effectively thriving in spite of the sector efforts, as the challenges being faced cannot be disregarded as well. It is important to note that this paper is partially supported by some existing literature, being particularly relevant the seminal work of Lousas et al. (2017), focused on the examination of the oil prices determinants in the olive oil industry in Portugal and Spain. Nevertheless, rather than focusing on prices, this research has an emphasis on the existing olive producing sector, having olive oil production as centrepiece of analysis. Several datasets covering recent decades were examined, allowing to examine the evolution of the olive oil production in a very long term period, namely since when the Iberian countries have assessed the European Union (EU). Since Portugal and Spain have joined the EU in 1986, this means that the determinants of olive oil production in the Iberian Peninsula countries were studied for a long period, covering a few decades. Therefore, very long time series were gathered, being the data obtained subject to examination. This paper starts with some insights about olive and olive oil. Then the production of olive oil is examined with particular focus on the Iberian, analysing the main determinants that may justify its variations. Finally, following the analysis of datasets collected and subject to basic statistics, as publication constrains limit the scope of analysis to be presented here, the results of the research are shown and discussed, ending the paper with the conclusions.

## **2. OLIVE OIL PRODUCTION**

The olive oil production is always challenging as it depends on the olive production conditions. Consequently, the production of olive oil may be greatly affected by random circumstances, such as atmospheric conditions or pests, being reasons like these ones justifying why production necessarily fluctuates every year (Pinto, 2003; Guerra, 2010). The EU is being producing about three-quarters of the total world production, with Spain, Greece and Italy figuring not only as the largest producers of olive oil in the EU, but worldwide as well (Tasdogan et al., 2005; IOC, 2018a).

This sector is very important for the European economy as it is one of the main industries (Guerra, 2010). As shown in Figure 1, in the most recent figures available for Europe, for 2017/18 crop season, Spain accounted about 57.5% of total production, followed by Italy with 19.7% and then Greece with 15.9%, and, finally, Portugal with 6.2%. The distance from these four major producers to the following ones is overwhelming, as then follows Cyprus with a mere 0.3%.

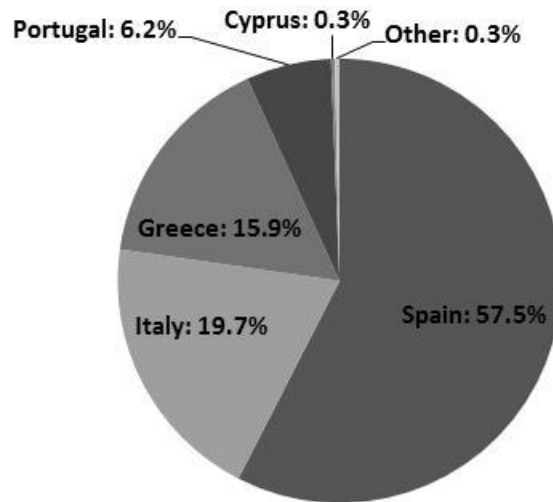

Figure 1: Main European olive oil producers in 2017/18's crop  
Source: Adapted from the IOC (IOC, 2018a)

The main contributor to the dominating Spanish production scenario is the region of Andalusia, which contributes with a producing value of around 179 million euros (Foundation for the promotion and development of olive groves and olive oil, 2009). In Portugal, the regions that produce the most olive oil quantities are the Trás-os-Montes and Alentejo, which are witnessing a great increase in recent years (Ministry of Agriculture for Rural Development and Fisheries, 2007; Sovena, 2017).

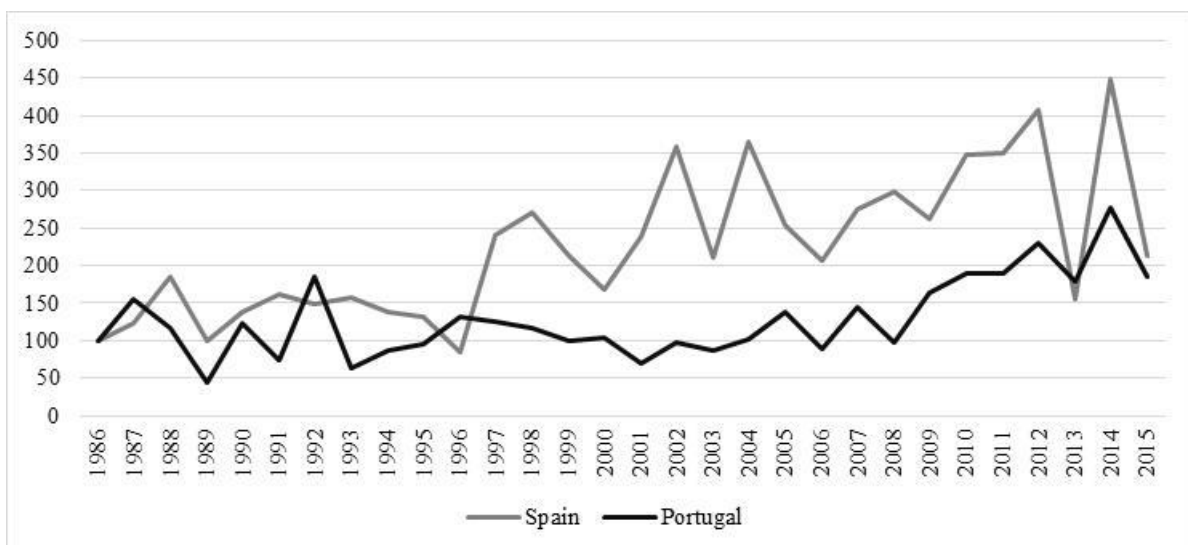

Figure 2: Evolution of olive oil production in Iberian Peninsula countries since EU accession  
Source: Adapted from collected data from INE (Statistics Portugal) and MARM (Ministry of Environment and Rural and Marine Affairs)

Nevertheless, while one could assume that the accession of the Iberian Peninsula countries, Portugal and Spain, to the EU in 1986 would provide good conditions for a strong increase in olive oil production, that did not occur, particularly in Portugal, where production remained stagnated in the first two decades from inception. As shown in Figure 2, Spain recorded a steep increase in production from mid-nineties, while Portugal only started to record a meaningful increase in recent years. In terms of classification, the IOC identifies several types of olive oil according to different distinguishing features, which include different degrees of acidity of the olive oil, the techniques used to produce it, the type of olives used, the types of olive groves and their chemical composition (Kiritsakis, 1992; Pires, 2005; IOC, 2018c). The acidity of olive oil is considered one of the basic criteria for differentiating types of olive oils (Kiritsakis, 1992). Furthermore, most consumers and buyers of olive oil do not recognize the quality of this product through the chemical analysis, or other evaluating processes, but rather simply through their degree of acidity (Pires, 2005). Accordingly, as IOC considers, the main types of the olive oil classes in Spain, and for most countries, are denominated by the following forms: extra virgin olive oil; virgin olive oil; ordinary virgin olive oil; lampante virgin olive oil (not fit for consumption); and refined olive pomace oil (Kiritsakis, 1992; Guerreiro, 2005; IOC, 2018c). According to the aforementioned classification, the best olive oil for human consumption will be the non-lampante olive oil (Observatory of Agricultural Markets and Agro-Food Imports, 2010; IOC, 2018c). For this reason, the extra virgin olive oil and virgin olive oil (non-lampante olive oil) have been conquering the market (Pinto, 2003; IOC, 2018c). As for Portugal, the quality standards consider that special extra virgin olive oil has a degree of acidity equal to or less than  $0.7^\circ$ , whereas the same olive oil type, by the IOC standards, may be recognized as below  $1^\circ$  acidity, most typically below  $0.8^\circ$  (Pires, 2005; IOC, 2018c). For the purpose of this research, the olive oil production is understood as the level of production, i.e. the quantity of agricultural product that is available, being in this case the quantity of product processed and available for sale (Statistics Portugal, 1999).

## 2.1. Climate

Climate is a major conundrum for the olive oil producers. Ordinary climate dynamics are itself puzzling, and the more recent climate change phenomena are just adding to the problem. For the oil producer the climate is the element over which he has no influence, and the only way to mitigate this obstacle is to have a good knowledge of the soil and thus to understand whether the olive trees are in proper vegetative condition (Eliard, 1988). Despite the uncertainty issue, it is important to note that when the climate conditions are favourable the olive oil production is favoured (Boel, 2009). Air and soil temperature, together with humidity conditions, affects the plants development process and the olive trees are no exception. The best temperatures for the olive tree to develop the photosynthesis phenomenon are between  $15^\circ\text{C}$  and  $30^\circ\text{C}$  (degree Celsius), as above these values the photosynthesis begins to be limited, producing between 70 to 80% of the normal level only (Eliard, 1988). The climate is one of the most important determinants impacting the formation of olives and therefore of the olive oil, both in quantity and quality terms. The climate factor affects its development, producing better or worse olive oil quality, depending on the atmospheric conditions affecting each harvest year (Kiritsakis, 1992). An olive grove with little water over a long period of time significantly limits the fruit and tree development. Ensuring proper irrigation for the olive groves is one of the crucial variables for better productivity, because every adequate olive tree development depends on proper water supply (Rodrigues & Correia, 2009).



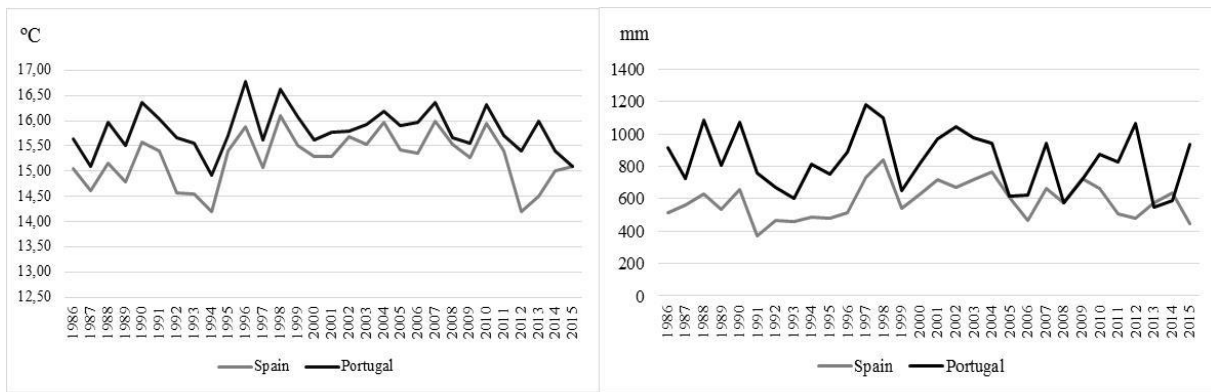

*Figure 3: Temperature in degree Celsius (left) and Precipitation in mm (right)  
Source: Adapted from collected data from INE (Statistics Portugal and Spain, 2016)*

In Figure 3 is shown the volatile whether conditions for Portugal and Spain in recent decades, with average temperature measured in degree Celsius (°C), and precipitation in millimetres (mm). The data exhibits a very random behaviour, full of peaks and downturns, resembling a random walk pattern, signalling very different crop conditions from year to year.

## **2.2. Olive production**

Somewhat similarly to the situation examined for the olive oil production, one could suppose that the accession to the EU would provide better conditions that could result on an increase of olive production, both in Portugal and Spain. As shown in Figure 4, that did not happen for the most of the 30 years timespan examined, being the situation particularly anaemic for Portugal. Overall, the performance of olive production was worst that the olive oil one, i.e. the growth on olive oil production was clearly superior, suggesting that both countries imported olives to support the increase of oil produced and traded. This production situation may be considering somewhat puzzling, as the official entities confirm the support to production. For example, according to the Portuguese Ministério da Agricultura do Desenvolvimento Rural e das Pescas, in mid-2000's it was found a slight increase in the level of olive production, due to the planting of new olive trees, because there was financial supporting coming from EU funds. Nevertheless, despite this increase, this was not sufficient for a positive progress in terms of the size of olive production (Ministry of Agriculture for Rural Development and Fisheries, 2007). Indeed, while Spain recorded a significant increase in olive production from mid-nineties, the production situation in Portugal was lacklustre.

*Figure following on the next page*

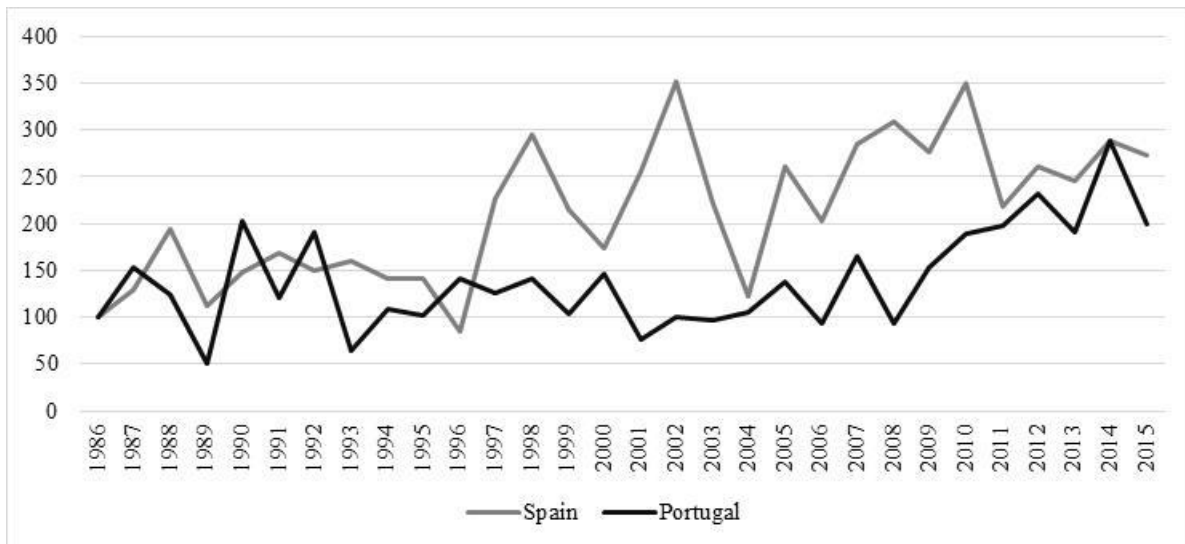

*Figure 4: Evolution of olive production in Spain and Portugal since EU accession*  
*Source: Adapted from collected data from INE (Statistics Portugal) and MARM (Ministry of Environment and Rural and Marine Affairs)*

Curiously, the olive production in Portugal appeared to have been enhanced from the financial crisis eventually, as since 2008 the production seems to have been consistently increasing, despite some decreases, as in the case of 2014/2015's crop, which can be attributed to bad weather conditions though (Statistics Portugal, 2016). The Mediterranean countries suffered particularly with the debt crisis, with Greece and Portugal being offered financial aid, while other countries have implemented austerity measures as well, as is the case of Spain and Italy. Such financial distressed situation, forced countries to improve their debt and deficit imbalances, which helped to refresh the focus on basic sectors of activity, as agriculture, to compensate the downturn registered in other economic sectors.

### **2.3. Olive groves area**

Following the discussion made about the olive and oil production conditions, remains to be examined the evolution in terms of agricultural area that has been devoted to olive groves. This research considers the cultivated area as the sum of utilized agricultural area for the cultivation of olive trees (Office of planning and agri-food policy & Directorate of plant production services, 2001; Statistics Portugal, 2010b), being available for observation, in Figure 5, the olive groves area evolution since 1986 for Portugal and Spain.

*Figure following on the next page*

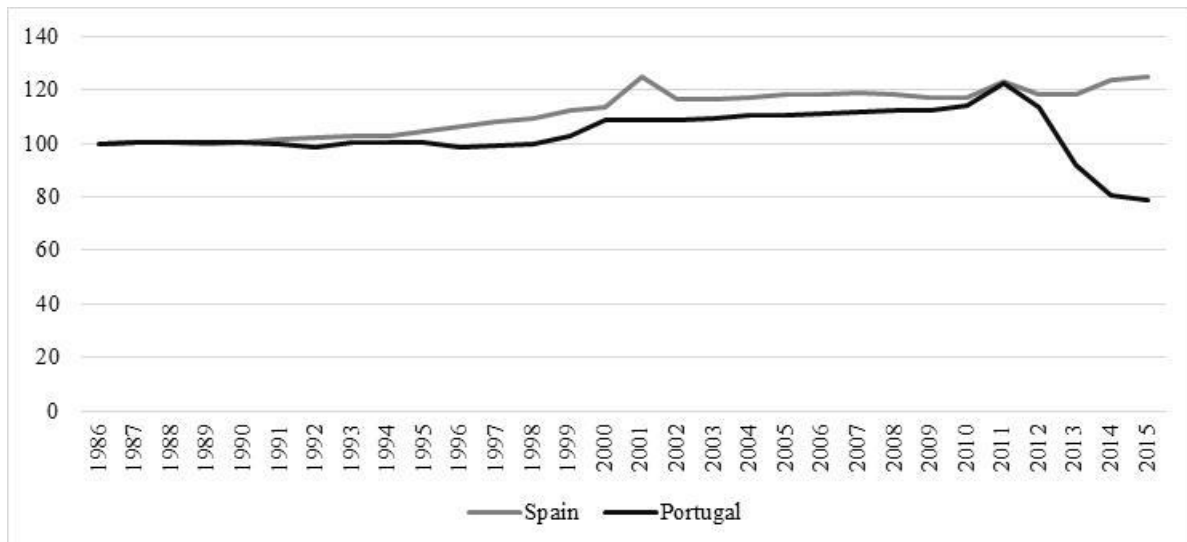

*Figure 5: Evolution of olive groves area in Spain and Portugal since EU accession*  
 Source: Adapted from collected data from INE (Statistics Portugal) and MARM (Ministry of Environment and Rural and Marine Affairs)

Likewise olive and oil production, the olive cultivated area did not record a very significant increase immediately after the EU accession. Furthermore, if on the very long run, i.e. for the thirty years analysed, the performance of the olive oil production growth was interesting, but not so much in terms of olive production, then in terms of olive area cultivated such performance is clearly the worst of all. Nevertheless, from mid-nineties that the area is been slowly increasing in Spain. For Portugal, only from late-nineties the area started increasing. However, is intriguing to observe that since 2012 the olive groves area has been decreasing sharply. Maybe this is a direct consequence of the extreme austerity measures that Portugal had to implement since 2011, when the international financial rescue plan started to be in place. That probably delayed the EU funds execution, leading farmers to freeze the investment in new olive groves, or even divesting, or moving to other more rentable farming types.

#### **2.4. Olive oil consumption**

In the case of this study, as it refers to the consumption of olive oil, it technically considers all the olives processed into mills, and every types of oil consumed are included as well (Statistics Portugal, 2010b). Expansion of olive oil worldwide was notorious from 1990 to 2009, as the world consumption of olive oil grew by 72.4%. Nevertheless, between 1994 and 2005 there was a worldwide increase olive oil consumption of around 3.5% per year (Ministry of Agriculture for Rural Development and Fisheries, 2007). As an example, globally, the 2009/10 harvest consumption reached 2,873 thousand tons and the forecast for 2010/11 was 2,978 thousand tons, surpassing thus the highest historical value of 2,923 thousand tons in the 2004/05 campaign (Ministry of Agriculture and Fisheries, Food and Environment, 2011). Portugal, Spain and France were among the Member States where the consumption of olive oil has grown more (Ministry of Agriculture for Rural Development and Fisheries, 2007). The increase in the consumption of olive oil by these countries may suggest that the concern of people with health and well-being is really a fact, because, as has been mentioned previously, olive oil is a product that may prevent the appearance of some diseases (Guerra, 2010). The European Union (EU) represents the part of the world with the highest production and consumption of olive oil (General Direction of Agriculture, 2002; Guerra, 2010). In the EU the consumption of olive oil in the period from 1990 to 2009 increased to 1,831.5 thousand tons in the 2009/10 season.

Within Communitarian Europe, Spain consumed 550 thousand tons, which meant 30% of the total EU consumption (Ministry of Agriculture and Fisheries, Food and Environment, 2011). In Figure 6 is represented the consumption of olive oil for Portugal and Spain. When analysing the graphs, we can observe that in Portugal, there has been a roughly constant growth, relative to the consumption of olive oil in the last 30 years. While for Spain consumption had some peaks, but it was not the case of such a constant trend.

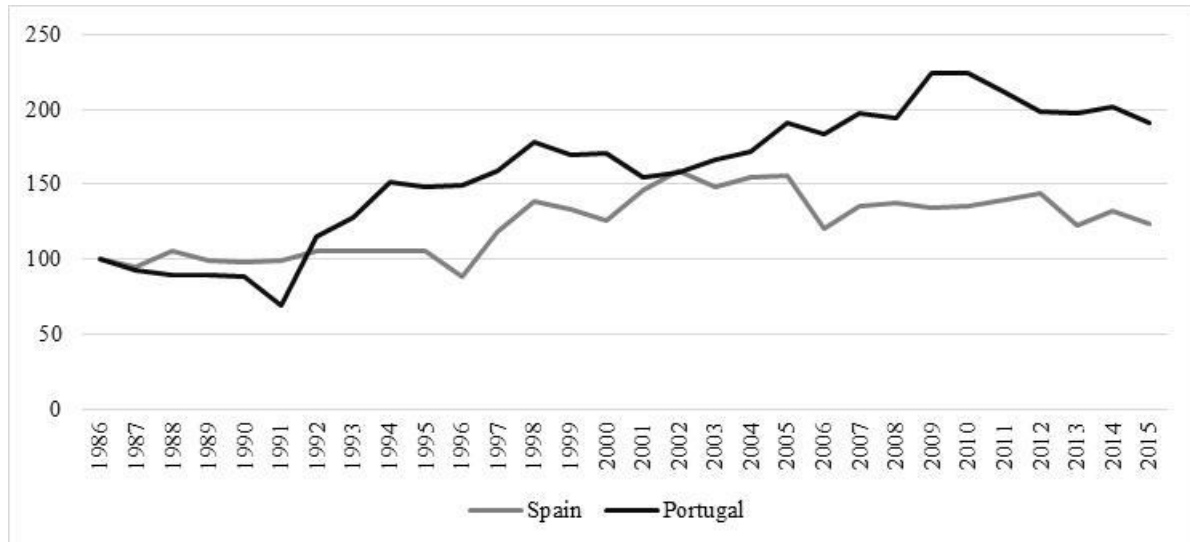

Figure 6: Evolution of olive oil consumption in Spain and Portugal since EU accession  
 Source: Adapted from International Olive Oil Council (IOC) data

During the campaign of 2014/15 consumption of olive oil in Spain reached 492,200 tons (Ministry of Agriculture and Fisheries, Food and Environment, 2015). In Portugal, the consumption of olive oil, according to the data shown in figure 6, in the 2014/2015 season was 74,450 tons (Statistics Portugal, 2016).

## 2.5. Olive oil prices

Data evolution examined hitherto did not revealed to be so much impressive. It is true that some data series for the Iberian Peninsula countries revealed doubling, tripling, and even quadrupling figures as in the case of olive oil production in Spain. However, such evolution reports to the time when both Spain and Portugal joined the EU and that was 30 years ago, according to the timespan examined. Furthermore, other variables did not present such growth performance, or needed many years since EU membership to finally record some meaningful increases. Not to mention the olive groves area case, that recorded a puzzling reduction for Portugal, or the very poor growth of oil consumption in Spain, where 30 years later the consumption is only 23% higher. Therefore, overall, we could empirically observe some impact from EU accession hitherto, but not a shocking one. That is not the case of the variables yet to be examined in this paper, starting with the current one, the evolution of olive oil prices. In technical terms, this research considers the price of olive oil as the amount received per unit sold, in monetary terms, being added to this amount every additional cost incurred for its preparation (Statistics Portugal, 2003). The olive oil market in the Iberian Peninsula improved when both Portugal and Spain joined the European Union in 1986. The factors that contributed mostly over time for this market to develop and grow were a mix of: a) reference prices; b) production subsidised; c) consumption promoted; d) protection of the domestic market through import taxes, refunds, and export subsidies (European Commission for Agriculture and Rural Development, 2003). By doing the analysis about the olive oil sector in Portugal, according to INE reports, when an

increase in the base price occurs, it usually turns out to be coincident with a bad agricultural year, meaning there were decreases in production volumes. When the harvest season is good, as in 2009, the production volume typically increases, thus achieving a high supply level, and therefore a lowering prices (Statistics Portugal, 2010a). Although the European Union market is increasingly integrated in terms of the olive oil trade, it is necessary to consider the specificities of the olive oil market. Despite this complexity, it is noted that there is a large difference between the prices of various types of olive oil, and among diverse producers as well, with large differences in some cases, as, for example, in the case of the price of extra virgin olive oil, which is much more expensive in Italy than in Spain (General Direction of Agriculture, 2003).

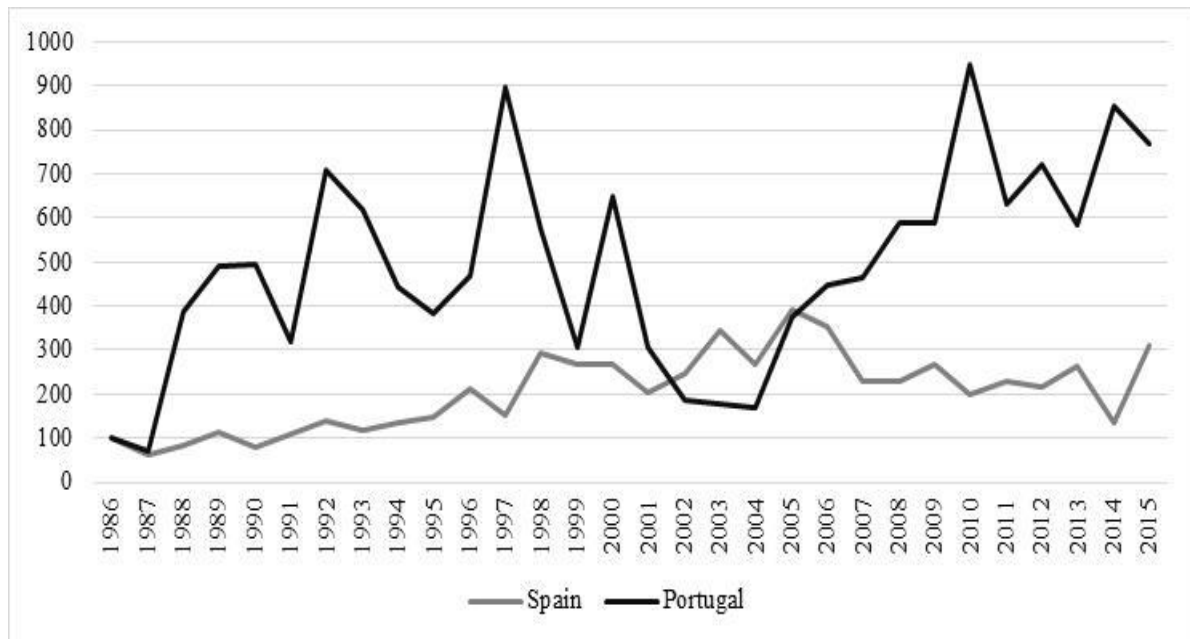

Figure 7: Evolution of olive oil prices in Spain and Portugal since EU accession  
Source: Adapted from INE and International Olive Oil Council (IOC) data

Figure 7 depicts the evolution in oil prices in the Iberian Peninsula. The “seasonality” for the different harvest conditions is well reflected in the continuing peaks, followed by immediate sharp decreases in data. Nevertheless, overall is clear that average prices rose since EU membership.

## 2.6. Imports and exports

The international trade consists essentially of imports and exports of olive and, most importantly. The European Union in terms of imports is at the top of the world scale, as it has a group of countries with high consumption of olive oil, such as the USA, Japan, Canada, Australia and Brazil (Ministry of Agriculture for Rural Development and Fisheries, 2007).

Imports of a product represent the entry of any goods into a country (Statistics Portugal, 1999), being the balance of trade of olive oil in Portugal of about 73,500 tons of olive oil imports. The quantity of olive oil produced by Portugal just satisfies about 50% to 60% of the needs of the Portuguese consumption (Observatory of Agricultural Markets and Agri-Food Imports, 2010). The oil imports to the Spanish economy, for example in the 2009/10 harvest, were only about 49.8 thousand tons (Ministry of Agriculture and Fisheries, Food and Environment, 2011), i.e. much less than for Portugal.

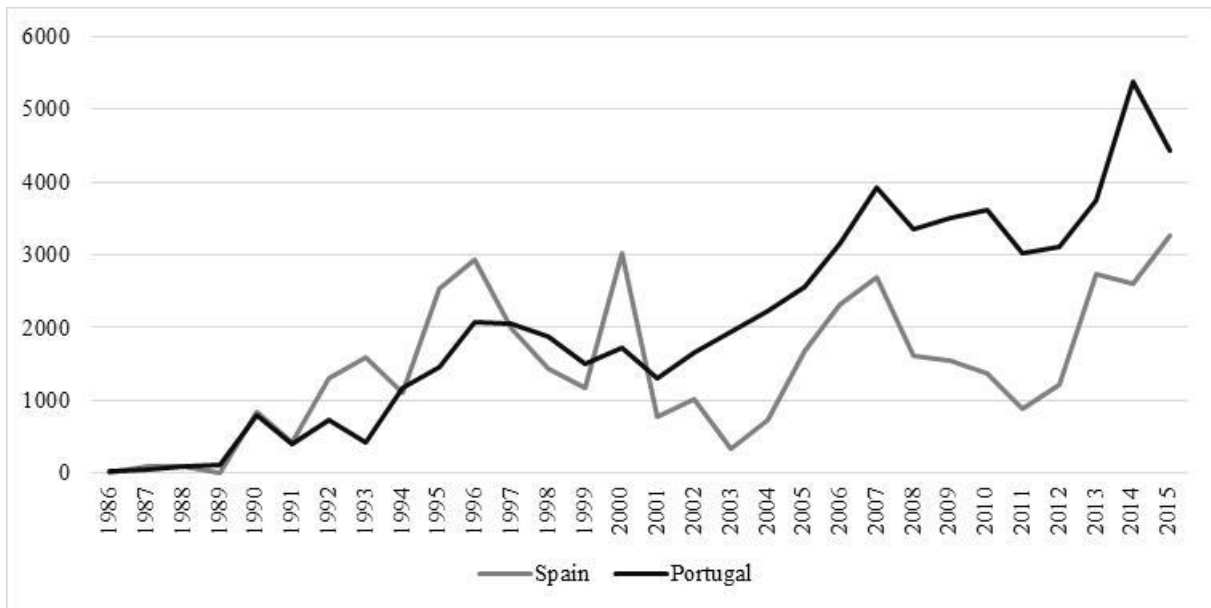

Figure 8: Imports of olive oil in Portugal and Spain since EU accession (Base year 1988 = 100)

Source: Adapted from collected data from INE and MARM (Ministry of Environment and Rural and Marine Affairs)

For a long time that the European Union is one of the main producers and as such is one of the main exporters, with around 90% of world exports, with Italy being the largest exporter followed by Spain, Portugal and Tunisia (Observatory of Agricultural Markets and Agri-Food Imports, 2010). When Greece, Portugal and Spain joined the EU, it became the first producer, importer, importer and exporter of olive oil. From this moment the EU has become the main agglomeration of countries in the world olive oil market (Ministry of Agriculture for Rural Development and Fisheries, 2007). In Portugal the trade balance of olive oil registers exports with around 33 thousand tons but, compared with the data described in the previous point (imports), it is possible to perceive that there is a deficiency, since imports are much higher than exports (Observatory of Agricultural Markets and Agri-Food Imports, 2010). The difference between imports and exports indicates the interest of imports to satisfy the consumption of olive oil of the Portuguese people (Ministry of Agriculture for Rural Development and Fisheries, 2007). Exports are equivalent to the outputs for international trade, i.e. is the trade of products for international countries (Statistics Portugal, 1999), being the European Union one of the main producers and as such is also one of the main exporters. Spain is one of the main exporters. During the harvest of 2014/15, the exports were about 831,194 tonnes (Ministry of Agriculture and Fisheries, Food and Environment, 2016). The country with the largest portion of Portuguese exports is Brazil, about 60% of total exports (Observatory of Agricultural Markets and Agri-Food Imports, 2010).

Figure following on the next page

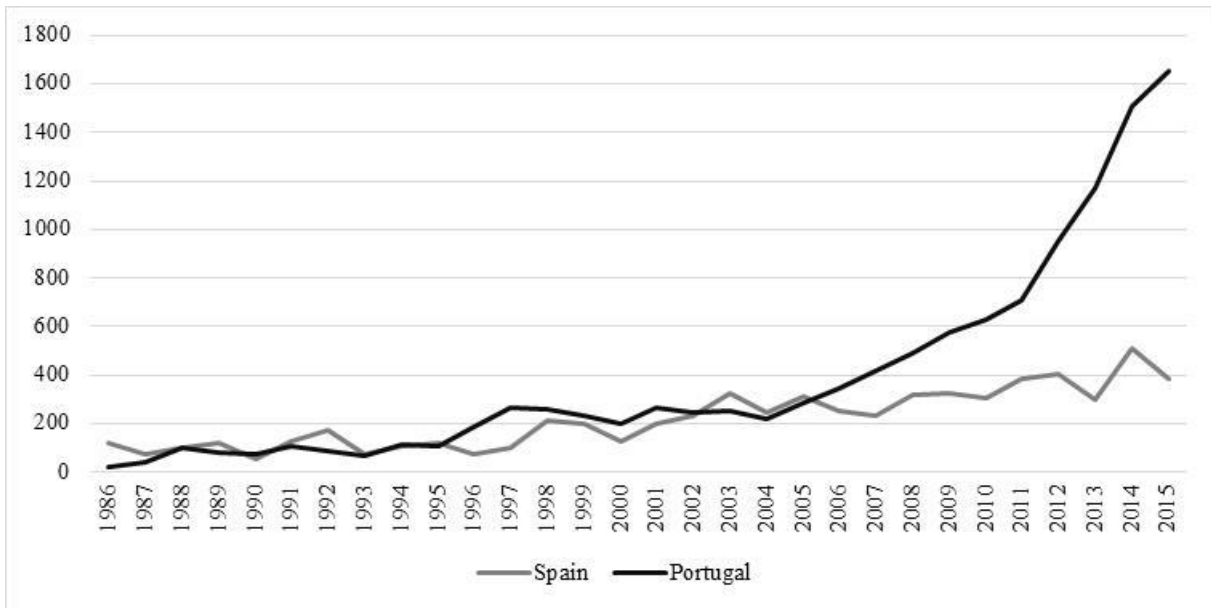

Figure 9: Exports of olive oil from Portugal and Spain since EU accession (Base year 1988 = 100)

Source: Adapted from collected data from INE and MARM (Ministry of Environment and Rural and Marine Affairs)

## 2.7. Domestic income

The domestic income is regarded here as gross national income, i.e. the total domestic and foreign income claimed by residents of a country. A number of factors may determine the socio-economic conditions of families. In this research we give particular emphasis to household income, olive oil prices and olive oil consumption, together with the health benefits and social trends, as discussed earlier. In this case the household income is the total income acquired through any social benefits, wages, and other net amounts received and resulting from work or capital activities, such as interest received (Rosa, 2010).

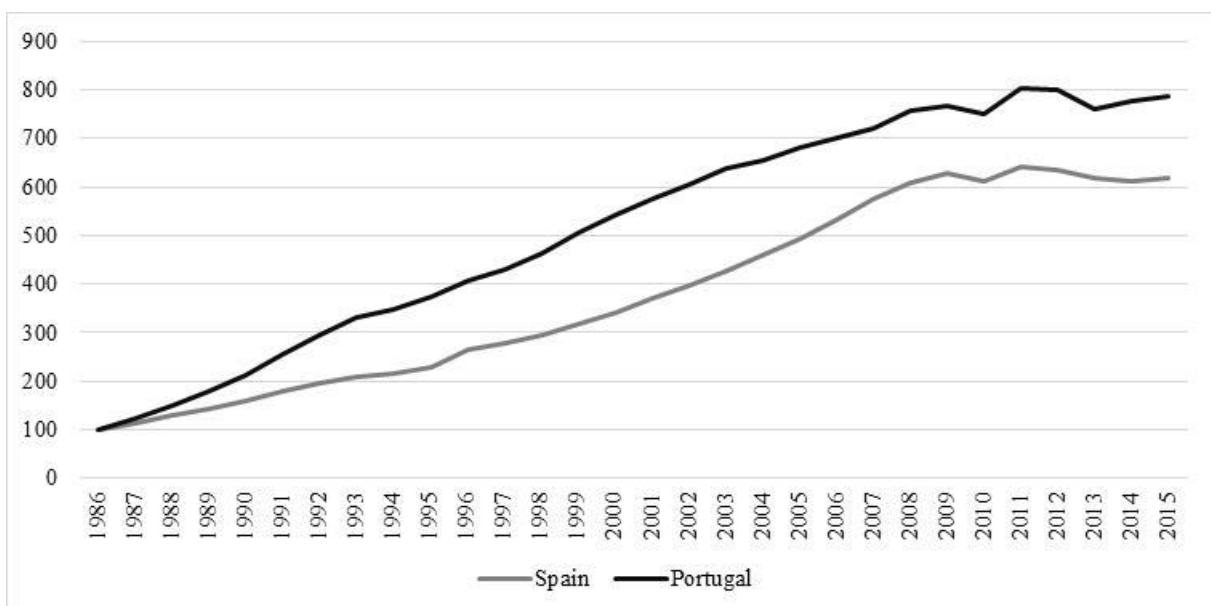

Figure 10. Evolution of Gross National Income in Spain and Portugal since EU accession  
 Source: Adapted from collected data from INE (Portugal and Spain).

Due to the economic crisis in Europe, families are becoming more indebted and therefore increasingly less sustainable. They are therefore more limited to the consumption of quality goods. An example that can be considered for this case is when there is a decrease in the income of the families that may cause a decrease in the amount sought of a higher quality product, as olive oil, which may be replaced by other types of cheaper oil, but of less quality and less healthy also.

### **3. METHODOLOGY**

This section provides the methodological tools used, consisting of the description of the problem, and the initial question definition, the construction of the research model with the hypotheses, the data and variables definition, and the main statistics employed.

#### **3.1. Description of the problem**

The initial question of this research was prepared as a scientific question, which includes the study of several variables and relationships between them, with the purpose to try achieving new theoretical and scientific contributions. In concrete, the research question prepared for this paper is: "Which factors significantly contribute to the variations on the production olive oil across the Iberian Peninsula?". For the exploration of this topic, research was made on some subjects within the theme, such as: what are the biggest oil producers in Europe; the main factors that influence the production in the countries covered by the research; and how the changes in the production olive oil in the Iberian Peninsula occurred over the last 30 years. With this research, we carry an analysis of the variables that may influence the evolution of the consumption of olive oil, and from this basis, an analysis model has been prepared enabling to understand, assess the possible determinants, and to study the factors that may explain the dynamics of production olive oil in the Iberian Peninsula. The data needed for this analysis was obtained from diverse literature reviews, consultations of various documents, and collections from some statistical databases such as the Portuguese and Spanish INE, Pordata, IOC (International Olive Council), and MARM, among others.

##### *3.1.1. Construction of the analysis model and research hypotheses*

The analysis model considers several factors that possibly influence the production olive oil (dependent variable) in the Iberian Peninsula. The independent variables were grouped into four main groups, as can be observed in figure 11, shown below, together with a set of research hypotheses. The following figure describes the research model that suggests the possible influence of several independent variables in the consumption of olive oil in order to try to assess the validity of the initial research question.

*Figure following on the next page*



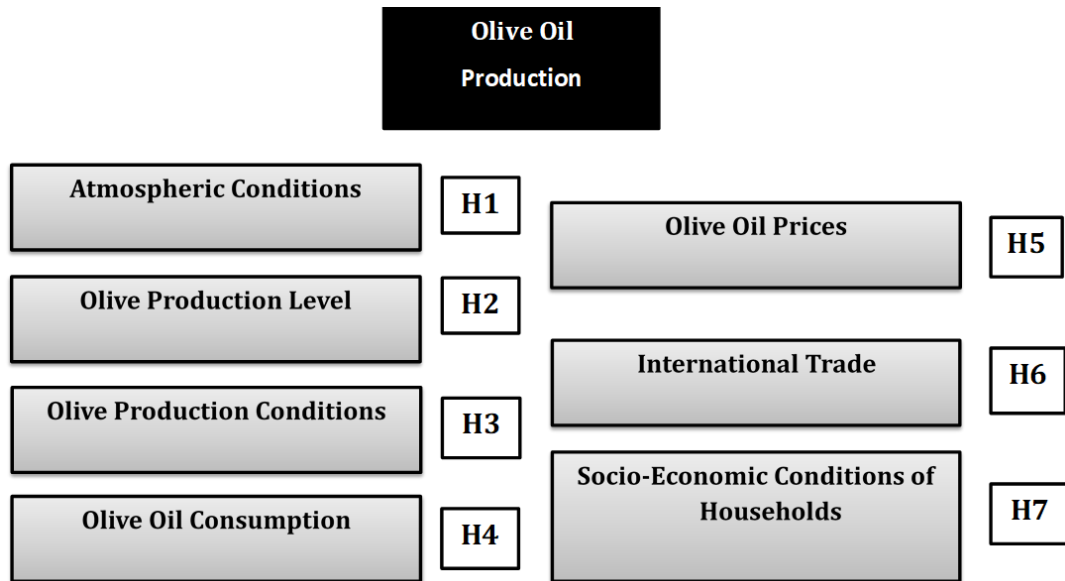

Figure 11: Research Model

Following to the research model that has been designed, as shown in Figure 11, the following research hypotheses are to be tested:

- H1: The production olive oil is influenced by weather factors, having as proxies: C (Weather in Celsius degrees centigrade (°C)); and PM (Average precipitation in millimetres (mm)), in the Iberian Peninsula;
- H2: Production olive oil is influenced by the level of production, taking into account the following factor: PAO (Production of olives as thousand tonnes (1000t)) in Spain and Portugal;
- H3: The production olive oil is influenced by the olive production conditions, having as proxies the factors: SC (Cultivation of olive trees measured in thousand hectares (ha)); and LA (Number of mills)) in Spain and Portugal;
- H4: The production of olive oil is influenced by the consumption of olive oil by Portuguese and Spanish households, measured by the variable: CA (Consumption of olive oil in metric tonnes (t));
- H5: The production olive oil is influenced by the Portuguese and Spanish families' olive oil prices, measured by the variable: PCA (Olive oil prices in thousands of euros (10<sup>6</sup>€));
- H6: The production olive oil in the Iberian Peninsula is influenced by international trade: E (Exports of olive oil from Portugal measured in euros (€), while for Spain they measured in tonnes (t)); and I (Imports of olive oil to Portugal that are measured in euros (€), while for Spain they are measured in tonnes (t));
- H7: The production olive oil is influenced by socio-economic conditions of households the Portuguese and Spanish families, measured by the variable: RNB (Gross national income in thousands of euros (10<sup>6</sup>€)).

Table 1, shown below, resumes the acronyms used for the variables constructed for the research presented in this paper.

Table following on the next page

*Table 1: Variables description*

<b>Code</b>	<b>Description</b>
• C	Weather in degrees centigrade (°C)
• CA	Consumption of olive oil in metric tonnes (t)
• PM	Average precipitation in millimetres (mm)
• PA	Oil production in tonnes (t) in Spain and Portugal in hectolitres (hl)
• PAO	Production of olives as thousand tonnes (1000t)
• SC	Cultivation of olive trees measured in thousand hectares (ha)
• LA	Number of mills
• E	Exports of olive oil to Portugal are measured in euros (€), while for Spain are measured in tonnes (t)
• I	Imports of olive oil to Portugal are measured in euros (€), while for Spain are measured in tonnes (t)
• RNB	Gross national income in thousands of euros (10 <sup>6</sup> €)
• PCA	Olive oil prices in thousands of euros (10 <sup>6</sup> €)

The data collected was preliminarily analysed, and several steps were further run in order to obtain valid results. The main step was the preparation of the datasets for the period to be examined, together with the research variables, which allowed later to calculate descriptive statistics, correlation matrices, and other statistics. The final step was the evaluation of the relationship between variables.

## **4. RESULTS**

In this section we present the major results obtained, concerning the proposed research hypotheses testing. Due to space constrains, this section is focusing on the results obtained using basic statistics, as shown in the appendices.

### **4.1. Preliminary analysis of the data**

The research faced some difficulties throughout the due process. Some may be considered as limitations of the research. Most noteworthy, in the first place, it was not always possible to find similar variables across the two countries; and, secondly, to obtain these variables calculated with the same numerical metrics/quantities. Accordingly, two further stages followed: the first, was to study the variables for the years 1986 to 2015, being this study carried out for both countries, but separately. The second step was to study every common variable for both countries. With this second step, we intended to get better results, having a better understanding of the variables that influence the production olive oil for both countries, simultaneously.

### **4.2. Descriptive statistics**

In Table A1 are depicted the descriptive statistics for Portugal, for the years 1986 to 2015; and Table A2 shows the descriptive statistics for Spain, for the same period of 1986 to 2015, as well. Both tables A1 and A2 can be found in the appendices. These tables analyse the changes that have occurred in recent years, showing descriptive statistics according to the study steps listed previously in this paper. Over the years of study, concerning Portugal, as depicted in Table A1, are shown some decreases in percentages, standing out variable I as the sharpest. Regarding the more recent ten years examined, there are some increases, although in some cases negligible, being possible distinguishing CA as the most significant increase. Continuing to observe Table A1, it appears that every final percentage are positive, while only three variables have negative percentages: C, SC and LA. Regarding the variations registered for Spain, available in Table A2, the oscillations are globally and substantially positive.

Secondly, it is observed that there is only a negative percentage, regarding the climate-atmospheric variables (C, PM), although the percentage significance is negligible. By taking into account the overall variation is denoted that the percentage is always positive, with the exception, again, of the PM variable.

### 4.3. Correlation Matrices

Tables B1 and B2, which are shown in appendices, represent the correlation coefficients matrices for the hypotheses tested. In Table B1, depicting Portugal correlation matrices for the years 1986 to 2015, are highlighted the variables pairs with the highest correlations values: PAO and PA; being another examples RNB with CA; and RNB with I. As for the Spanish country, according to Table B2, depicting correlation matrixes for 1986 to 2015, are underlined the variables SC and RNB, as the ones with the highest correlation values.

## 5. CONCLUSIONS

Throughout this paper were studied factors possibly influencing the determination of the production olive oil in Spain and Portugal. To achieve results, it was necessary to find an appropriate dataset, supported by reliable sources. Due to space constrains, this section is focusing on the main results obtained from basic statistics, which were employed to test the hypotheses developed and depicted before in this paper. The trifling number of correlations obtain suggest that most research hypotheses cannot be accepted. We have found evidence to do not reject Hypothesis two, i.e. the production of olive is likely to influence the yearly amount of olive oil produced. Another limitation of this study is concerning some difficulties to obtain data for variables that should be equal or similar for both countries analysed. As a consequence of this lack of data uniformity we could not use the same variables for Spain and Portugal. This lack of consistency within the time series also forced the authors to reduce the period of analysis. This paper aimed to achieve more knowledge about the determinants of the production olive oil, in particular to understand which variables influence more the production, in a statistically manner, and to examine whether such variables would produce similar results for the two countries under study. As a suggestion for further research, we would like to recommend expanding the scope of analysis, possibly increasing the number of years of study. Furthermore, studying other olive oil-producing countries, such as Italy and Greece, would increase the dataset, possibly adding further interesting insights. It would also be interesting to add some other research variables, such as the income of farmers, subsidies and aid for production, or the number of olive trees negotiated. The use of such variables is obviously depending of an enhancement of the statistical databases across the major countries producing olive oil. In terms of findings for more recent years, it was possible to conclude that despite the increasing recognition of the benefits of olive and olive oil by the society, and despite the increase in olive production, the consumption of olive oil has been decreasing internally, being replaced by increases in exports. This is most probably due to the economic conditions that have deteriorated due to the 2008's financial crisis, which, together with an increase in olive oil prices, has prevented a considerable portion of the population to have financial conditions to access to the consumption of such an important component of the Mediterranean diet.

### LITERATURE:

1. Boel, M. F. (2009). Retrieved April 22, 2015, from Europarl:  
<http://www.europarl.europa.eu/sides/getAllAnswers.do?reference=P-2009-2359&language=PT>
2. Eliard, J.-L. (1988). *Manual global da agricultura* (2<sup>a</sup> ed.). (F. L. Castro, Ed.) Portugal: Publicações Europa-América.

3. European Commission for Agriculture and Rural Development. (2003). *Agriculture and Rural Development*. Retrieved March 24, 2016, from European Commission: [ec.europa.eu/agriculture/eval/reports/oliveoil/sum\\_en.pdf](http://ec.europa.eu/agriculture/eval/reports/oliveoil/sum_en.pdf)
4. Foundation for the promotion and development of olive groves and olive oil. (2009). *Olive oil: Proceedings of the scientific-technical symposium EXPOLIVA 2007*. (p. 660). Jaén, Spain: Foundation for the promotion and development of olive groves and olive oil.
5. General Direction of Agriculture. (2002). *European Commission*. (E. L. Lacroix, Ed.) Retrieved April 22, 2015, from europa.eu: [http://ec.europa.eu/agriculture/publi/fact/oliveoil/2003\\_pt.pdf](http://ec.europa.eu/agriculture/publi/fact/oliveoil/2003_pt.pdf)
6. General Direction of Agriculture. (2003). *Agriculture and Rural Development*. Retrieved May 30, 2011, from European Commission: [http://ec.europa.eu/agriculture/markets/olive/reports/rep\\_en.pdf](http://ec.europa.eu/agriculture/markets/olive/reports/rep_en.pdf)
7. Guerra, I. R. (2010). *Análisis cuantitativo y cualitativo del significado del aceite de oliva. Una aproximación desde el punto de vista del consumidor*. Granada: Editorial de la universidad de Granada.
8. Guerreiro, A. G. (2005). *Cultivo moderno do olival*. Mem Martins, Portugal: Publicações Europa-América.
9. IOC. (2018a). *World olive oil figures*. Retrieved June 30, 2018, from International Olive Oil Council: <http://www.internationaloliveoil.org/estaticos/view/131-world-olive-oil-figures>
10. IOC. (2018b). *International Olive Council Mario Solinas Quality Award: Prize winners and finalists*. Madrid: International Olive Council.
11. IOC. (2018c). *Designations and definitions of olive oils*. Retrieved June 29, 2018, from International Olive Council: <http://www.internationaloliveoil.org/estaticos/view/83-designations-and-definitions-of-olive-oils>
12. Kiritsakis, A. K. (1992). *El aceite de oliva*. Madrid: A. Madrid Vicente.
13. Lousas, C., Ribeiro, H., Alves, S., & Veloso, C. (2017). The Olive Oil Prices Determinants from Production to Retail: A Study of the Olive Oil Sector in Portugal and Spain. *Annual EuroMed Academy of Business Book Proceedings*, pp. 857-872.
14. Ministry of Agriculture and Fisheries, Food and Environment. (2011). *Análisis de mercado del aceite de oliva. Campaña 2009/2010*. Retrieved May 31, 2015, from Junta de Andalucía: <http://www.juntadeandalucia.es/agriculturaypesca/portal/export/sites/default/comun/galerias/galeriaDescargas/cap/servicioestadisticas/Estudioseinformes/agricultura/olivar/oli11021400.pdf>.
15. Ministry of Agriculture and Fisheries, Food and Environment. (2015). *Encuesta sobre superficies y rendimientos de cultivo*. Madrid: Ministry of Agriculture, Food and Environment. Retrieved June 20, 2016, from Ministerio de Agricultura y Pesca, Alimentación y Medio Ambiente: <http://www.mapama.gob.es/es/agricultura/temas/producciones-agricolas/aceite-oliva-y-aceituna-mesa/>
16. Ministry of Agriculture and Fisheries, Food and Environment. (2016). *Comercio Exterior del aceite de oliva español-campaña 2014/2015*. Madrid: Gobierno de España.
17. Ministry of Agriculture for Rural Development and Fisheries. (2007). *Olivicultura - diagnóstico sectorial*. Retrieved April 18, 2015, from MADRP: [http://www.gppaa.min-agricultura.pt/pbl/diagnosticos/Azeite\\_\\_Diagnostico\\_Sectorial.pdf](http://www.gppaa.min-agricultura.pt/pbl/diagnosticos/Azeite__Diagnostico_Sectorial.pdf)
18. Observatory of Agricultural Markets and Agri-Food Imports. (2010). *Evolution of the balance of payments in the olive oil sector between 2000 and 2009*. Retrieved June 01, 2015, from Confagri: <http://www.confagri.pt/Download/Balan%C3%A7aAzeite.pdf>

19. Office of planning and agri-food policy & Directorate of plant production services. (2001). *Common organization of the market in olive oil*. Lisbon: Office of Planning and Agri-Food Policy.
20. Pinto, L. (2003). *Azeite e ambiente*. Retrieved April 13, 2015, from Confederação Nacional da Agricultura: em: <http://www.cna.pt/atautor.htm>.
21. Pires, D. R. (2005). *Estudo de Valorização Comercial do Azeite*. Mirandela: Instituto Politécnico de Bragança - Escola Superior Agrária.
22. Rodrigues, M. Â., & Correia, C. M. (2009). *Manual da safra e contra a safra do olival*. Bragança: Polytechnic Institute of Bragança.
23. Rosa, M. J. (2010). *Rendimento e poupança das famílias*. Obtido em 06 de June de 2015, de Pordata - Base de dados Portugal contemporâneo: <http://www.pordata.pt/Site/Workspace.aspx>
24. Sovena. (2017). *Sustainability Report 2016*. Algés, Portugal: Sovena Group.
25. Statistics Portugal. (1999). *Portuguese food balance 1990-1997*. Lisbon: INE-Instituto Nacional Estatística.
26. Statistics Portugal. (2003). *Agricultural Statistics 2002*. Lisbon: INE-Instituto Nacional Estatística.
27. Statistics Portugal. (2010a). *Economic accounts for agriculture 1980-2009*. Lisbon: INE-Instituto Nacional Estatística.
28. Statistics Portugal. (2010b). *Agricultural Statistics 2009*. Lisbon: INE-Instituto Nacional Estatística.
29. Statistics Portugal. (2016). *Agricultural Statistics 2015*. Lisbon: INE-Instituto Nacional Estatística.
30. Tasdogan, C., Tsakiridou, E., & Konstadinos, M. (2005). Country market power in UE olive oil trade. *Vol. 2*, pp. 211-219.

**APPENDIX**

*Table A1: Descriptive statistics of Portugal for several periods from 1986 to 2015*

Year	PA	C	PM	PAO	SC	LA	I	E	RNB	PCA	CA
Δ 1986-90	23,70%	4,68%	17,04%	103,43%	0,54%	2,45%	1942,12%	231,46%	111,99%	392,94%	-11,54%
Δ 1990-00	-15,30%	-4,62%	-23,58%	-28,11%	8,36%	-37,72%	113,32%	153,84%	155,95%	31,50%	92,75%
Δ 2000-10	80,35%	4,48%	6,37%	29,24%	4,84%	-36,50%	109,60%	218,90%	38,08%	46,28%	31,58%
Δ 2011-15	-2,42%	-7,44%	7,46%	5,62%	-30,98%	-15,66%	23,16%	162,98%	5,12%	-19,11%	-14,91%
Δ 1986-2015	84,39%	-3,45%	2,23%	99,61%	-21,16%	-65,83%	11145,02%	6955,97%	687,60%	667,06%	90,90%
Average	464001	15,81	836,98	306,47	350,81	854,77	108468,00	87837,10	1,12E+08	4,17	61,95
Median	424210	15,74	824,44	287,92	340,63	770,00	101198,00	56704,20	1,21E+08	4,07	61,50
Std.-Deviation	190198	0,43	180,18	118,00	31,48	338,34	75783,40	95303,50	5,04E+07	1,96	17,14
Minimum	157293	14,91	551,00	110,33	267,01	474,00	2090,02	5285,92	2,16E+07	0,59	27,00
Maximum	999853,00	16,77	1180,21	634,21	441,34	1700,00	284100,00	372973,00	1,74E+08	8,06	87,50

*Table A2: Descriptive statistics of Spain for several periods from 1986 to 2015*

Year	PA	C	PM	PAO	SC	I	E	RNB	PCA	CA
Δ 1986-90	38,67%	3,45%	27,41%	48,06%	0,60%	299557,14%	-56,52%	60,61%	-21,80%	-2,49%
Δ 1990-00	21,20%	-1,71%	-3,67%	17,46%	12,64%	254,17%	135,07%	112,17%	241,30%	29,50%
Δ 2000-10	107,39%	4,25%	4,92%	101,50%	3,60%	-54,28%	140,10%	79,21%	-24,95%	7,32%
Δ 2011-15	-39,16%	-5,33%	-32,45%	-22,26%	6,34%	137,75%	26,70%	1,13%	54,34%	-8,75%
Δ 1986-2015	112,04%	0,36%	-13,02%	172,44%	24,85%	1153442,86%	210,92%	517,57%	209,15%	23,67%
Average	893,98	15,24	588,08	4219,40	2334,80	71337,00	469840,00	6,40E+05	1661,30	493,07
Median	839,55	15,33	575,75	4314,60	2396,90	66216,00	447940,00	6,00E+05	1729,70	497,40
Std.-Deviation	385,76	0,52	112,63	1478,20	179,46	47756,00	257430,00	3,22E+05	714,10	81,13
Minimum	336,08	14,19	373,00	1694,20	2086,70	14,00	116242,00	1,69E+05	499,87	352,10
Maximum	1781,50	16,09	841,00	6982,52	2605,20	161500,00	1102900,00	1,08E+06	3176,10	631,20

*Table B1: Correlation matrix for Portugal for the period from 1986 to 2015*

PA	C	PM	PAO	SC	LA	I	E	RNB	PCA	CA	
1,000	-0,135	-0,079	0,944	-0,204	-0,249	0,653	0,740	0,481	0,557	0,497	PA
	1,000	0,230	-0,043	0,231	-0,028	0,030	-0,238	0,036	-0,079	0,047	C
		1,000	0,004	0,105	0,139	-0,187	-0,154	-0,163	-0,045	-0,153	PM
			1,000	-0,261	-0,162	0,584	0,689	0,388	0,554	0,368	PAO
				1,000	-0,253	-0,028	-0,367	0,272	-0,174	0,287	SC
					1,000	-0,791	-0,647	-0,918	-0,302	-0,808	LA
						1,000	0,841	0,906	0,545	0,880	I
							1,000	0,713	0,554	0,632	E
								1,000	0,404	0,936	RNB
									1,000	0,465	PCA
										1,000	CA

*Table B2: Correlation matrix for Spain for the period from 1986 to 2015*

PA	C	PM	PAO	SC	I	E	RNB	PCA	CA	
1,000	0,250	0,393	0,722	0,719	0,093	0,777	0,726	0,340	0,791	PA
	1,000	0,509	0,281	0,259	0,111	0,059	0,176	0,383	0,360	C
		1,000	0,400	0,277	-0,079	0,126	0,169	0,268	0,539	PM
			1,000	0,705	0,251	0,675	0,711	0,465	0,724	PAO
				1,000	0,436	0,848	0,916	0,704	0,798	SC
					1,000	0,271	0,474	0,399	0,071	I
						1,000	0,890	0,549	0,694	E
							1,000	0,649	0,697	RNB
								1,000	0,713	PCA
									1,000	CA

## ENTERPRISE IN TURBULENT ENVIRONMENT – INFLUENCE OF ENVIRONMENTAL POLICY IN POLAND

**Aleksandra Ferens**

*University of Economics in Katowice, Poland*  
*aleksandra.ferens@ue.katowice.pl*

### **ABSTRACT**

*Growing competition, increased complexity of internal and external processes as well as changing customer expectations force managers to adapt to new market conditions. The response to the growing turbulence of the environment is the adoption of a process management model in the enterprise that takes into account environmental aspects that support an important process - gathering and presenting environmental information in the form of management environmental reports. Environmental reports prepared by energy sector companies are obligatory, but there is also a second group of reports that the entity draws up, resulting from voluntary environmental management instruments that include ISO standards systems. According to the author, the environmental policy of the State exerts a huge influence on the environmental strategy of enterprise development, which is based on environmental management. Thanks to the implementation of this management model, it is possible to efficiently and comprehensively generate environmental information in the entity, contributing to limiting and rectifying adverse business impacts, assessing the company's environmental impact and adapting to environmental law, etc.*

**Keywords:** *environmental information, state's environmental policy, turbulent business environment*

### **1. INTRODUCTION**

Nowadays, organizations function in a constantly and rapidly changing environment, which influences and shapes their activities to a smaller or larger degree. This environment is characterized by high volatility, competitiveness, strong position of customers and tends to accelerate, which is why it is described as turbulent. Changes in the environment regarding the political, market, economic, social, as well as technological and ecological sphere, force organizations to constantly adapt to it through the use of appropriate adaptation processes. The turbulent business environment forces the organizations to constantly monitor the changes taking place as well as the high flexibility of action and quick response to emerging signals from the environment. The answer to these phenomena is, among others the adoption of a process management model by enterprises, taking into account ecological aspects. The increase in the importance of environmental information generated and presented by individual enterprises is caused by the development of environmental and ethical standards. Environmental information is interpreted differently in the literature. In accordance with the Act on sharing information about the environment and its protection (Journal of Laws 2008 no. 199, item 1227, paragraph 9), this information refers to:

- the condition of individual elements of the environment
- emissions, pollutants that affect or may affect particular elements of the environment, measurement techniques,
- reports on the implementation of environmental legislation,
- cost-benefit analyzes and other economic analyzes,
- legal regulations concerning the environment and water management, activities aimed at protecting the environmental elements,
- health, safety and living conditions of people.

As it follows from the presented definition, the scope of environmental information is very wide and involves not only its identification, but also presentation in the form of environmental reports. The content of these reports concerns the current and desired status regarding individual elements of the environment (e.g. information on the emission volume of pollutants). It should be emphasized, however, that the need to present this information stems primarily from recommendations and obligations regarding the protection and shaping of the natural environment to the extent which is affected by the environmental policy of the state, conducted in Poland in accordance with the principle of balanced and sustainable development. The aim of the paper is to present the role of the state's environmental policy in shaping the scope of environmental information resulting from selected obligatory and optional sources of law regarding entities in the energy sector that shape the position of an enterprise operating in a turbulent business environment. The basic research method is the meta-analysis of environmental regulations (obligatory and optional) applicable to energy sector companies and selected environmental reports prepared by energy sector entities.

## **2. STATE'S ENVIRONMENTAL POLICY**

The state's environmental policy sets out the rules, ways, limits of using the environment by enterprises and responsibility for damage caused (Lisiecka, Kubasik, 2001, p. 45). The growing importance of the state's environmental policy resulted in the feedback existing at different times and in varied scope between the natural environment and the enterprise, as well as the need to manage these relations in terms of threats and opportunities for the development of the organization. Policy is a concept that has many meanings. According to K. Opalek (2007), policy is an activity determined by a decision center of a formalized social group (organization), aiming at achieving set goals by means of specific measures. Policy is also defined as the art of governing the state, i.e. the general activity of state power, directed at achieving or defending specific goals. The most common are: general policy of the state (dependent on the socio-economic system and existing reality), departmental and instrumental policies and problem policies, among which we distinguish environmental policy (Górka, Poskrobko, Radecki, 2001, p. 63). Environmental policy is defined as the conscious and purposeful activity of the state, self-government authorities and economic entities in the field of environmental management, that is, the use of its resources and assets, protection and shaping of ecosystems or selected elements of the biosphere (Górka, Poskrobko, Radecki, 2001, p.64). The environmental policy should fulfill its proper functions, define environmental protection objectives, indicate the means for their implementation and specify the methods of implementation, including the necessary organizational instruments and solutions. The nature of environmental policy depends on the adopted functions, objectives, priorities, preferred rules, type of actions taken and measures necessary to achieve these goals. The basic functions of environmental policy in the literature are (Górka, Poskrobko, Radecki, 2001, p.65):

- indication of the objectives of pro-ecological activities,
- defining the basic conditions for achieving goals, including:
  - ✓ principles of functioning of environmental policy,
  - ✓ hierarchy of goals,
  - ✓ tasks ensuring the achievement of goals,
- indication of factors facilitating and hindering the achievement of the assumed goals,
- indication of the most advantageous ways (means, tools, instruments) to achieve the set goals.

The state environmental policy is continuous and is updated depending on the conditions and needs. One of the first documents that played a significant role in shaping the functions, objectives of environmental policy and pro-environmental activities in Poland was 'the State



Environmental Policy', which was adopted by the Sejm in 1991. The assumptions of this policy include ecological and social aspects (Pakulska, Rutkowska, 2000, pp. 104-105). In this document, ecological criteria began to be treated equally with economic ones. Environmental protection and social needs become an element of management and ensured the foundations of sustainable economic development. The overriding objective of environmental policy was therefore to preserve or improve the natural environment's assets<sup>1</sup>. Changes in the socio-economic and political situation, Poland's accession to international conventions and agreements, unfavourable indicators of the consumption of natural resources and the state of the environment in Poland contributed to drawing up another document which is the 'the Second Environmental Policy of the State'. It is a document adopted in 2001, of a conceptual and strategic character, in which the assumptions and objectives of this policy were established in the 2025 perspective. The overriding priority of the Second Environmental Policy of the State, which is continued in subsequent documents, was to ensure ecological security for the Polish society and to create the basis for the preparation and implementation of the country's sustainable development strategy<sup>2</sup>. Another document updating the Second National Environmental Policy and indicating the directions of activities in the field of the environment was 'National Environmental Policy for 2007-2010, taking into account the outlook for 2011-2014' and the country's environmental policy in 2009-2012 with the 2016 perspective, as well as ongoing work on the 'Environmental Policy of the State 2030'. These documents can be treated as a medium-term and long-term program of activities, which is related to the implementation of obligations related to the need to effectively implement the requirements resulting from the European Union's environmental protection regulations. It is assumed that the objective of environmental policy resulting from its subject and function should be the achievement and then preservation of the environment that will ensure the development of society, minimize or completely eliminate environmentally-conditioned diseases, and improve the environmental state in the areas that are degraded or significantly damaged (Górka, Poskrobko, Radecki, 2001, p. 65, Pakulska, Rutkowska, p. 99). The overriding principle in accordance with the Second Ecological Policy of the State is the principle of sustainable development, which in terms of policy should treat equally: social, economic and ecological goal, which involves the integration of environmental issues with sectoral policies. Tactical (implementation) tasks related to the documents concern, among others, improving legal, administrative and economic mechanisms for regulating the use of the environment, which are both laws and regulations in the field of environmental protection, among others Environmental Protection Law (Journal of Laws 2018, item 1722), the Waste Act (Journal of Laws 2018, item 1522), the Water Law Act (Journal of Laws 2017, item 1722), the Act on packaging and packaging waste, Journal of Laws 2013, item 888), the Act on the obligations of entrepreneurs in the management of certain waste and the product fee (Journal of Laws 2018, item 1932), regulations regarding environmental quality standards, emission and sewage standards, technical standards, as well as tax acts, Penal Code, Accounting Act, International Accounting Standards, etc. These sources of law affect and define the scope of environmental information created by individual business entities.

---

1 In a similar way, the objective of environmental policy can be formulated on the basis of the Environmental Protection Law – as creating conditions necessary to implement environmental protection in accordance with the principle of sustainable development, see: Environmental protection law (Journal of Laws 2018, item 1722, paragraph 13)

2 Providing citizens with environmental security, social infrastructure and natural resources means the necessity of the greening of sectoral policies, which consists in integrating approaches to formulating goals, strategies, policies and executive programs with the objectives of environmental policy. Through the ecologicalisation of sectoral policies and taking into account ecological policy recommendations in all strategic documents and programs, it is possible to implement the constitutional principle of balanced and sustainable development. In addition, it should be noted that this objective is one of the objectives of the European Union's environmental policy.

### 3. ENVIRONMENTAL LEGAL ACTS APPLICABLE TO ENERGY SECTOR ENTERPRISES

The business operations of energy sector enterprises are to a large extent determined by the state's ecological policy and international agreements, guidelines, standards and norms. The possibility of staying in the market is connected not only with the necessity of applying Polish legal regulations, but also with adapting to the requirements of the European energy market by meeting certain environmental standards. The impact of energy sector enterprises on the natural environment applies to a wide range of factors including air, noise, waste, water, sewage, radiation, etc. A list of the most important legal regulations, standards and guidelines applicable to energy sector entities, including the subject of regulations, is provided in Table 1.

*Table 1: Environmental legal acts, agreements, permits, administrative decisions applied in the energy sector entity (own elaboration)*

TYPE OF NORMS	SUBJECT OF REGULATIONS
<ul style="list-style-type: none"> <li>• Regulation of the Minister of the Environment of 1 March 2018 regarding emission standards for certain types of installations, fuel combustion sources and waste incineration or co-incineration devices (Journal of Laws of 2018, item 680)</li> <li>• Regulation of the Minister of the Environment on the requirements for the measurement of emissions (Journal of Laws 2018, item 1022)</li> <li>• Integrated permit for fuel combustion installations granting permits for emission of gases and dusts to air,</li> <li>• Act of 12 June 2015 on the greenhouse gas emission allowance trading scheme (Journal of Laws 2015 item 1223)</li> <li>• Regulation of the Minister of the Environment of 12 September 2008 on the method of monitoring the emissions of substances covered by the EU Emissions Trading Scheme (Journal of Laws 2008, No. 183, item 1142)</li> <li>• Regulation of the Minister of Environment of 6 June 2018 on the scope and manner of providing information on air pollution (Journal of Laws 2018, item 1120)</li> <li>• Regulation of the Minister of the Environment of 27 September 2011 on the percentage share of emission allowances, which in the settlement period starting from 1 January 2013 may be granted to installations covered by the greenhouse gas emission allowance trading scheme (Journal of Laws 2011, No. 203, item 1944)</li> <li>• Act of 20 February 2015 on renewable energy sources (Journal of Laws 2015, item 478)</li> </ul>	<p style="text-align: center;"><b>Air - dust emission, SO<sub>2</sub> emission, NO<sub>x</sub>, CO<sub>2</sub> emission</b></p>
<ul style="list-style-type: none"> <li>• Decree of the Minister of the Environment of 15 October 2013 on the publication of a uniform text of the Regulation of the Minister of the Environment regarding permissible noise levels in the environment (Journal of Laws 2014, item 11)</li> <li>• Integrated permit for fuel combustion installations</li> </ul>	<p style="text-align: center;"><b>Noise</b></p>
<ul style="list-style-type: none"> <li>• Act of 14 December 2012 on waste (Journal of Laws 2018, item 1592),</li> <li>• Integrated permit for fuel combustion installations</li> <li>• Regulation on the implementation of the 'Waste Management Manual'</li> <li>• Commission Regulation (EU) 2015/830 of 28 May 2015 amending Regulation (EC) No 1907/2006 of the European Parliament and of the Council on the Registration, Evaluation, Authorization and Restriction of Chemicals (REACH)</li> <li>• Contract for the collection of metal scrap, electronic and electro-technical equipment, cables, lead-acid batteries</li> <li>• Regulation of the Minister of the Environment of December 9, 2014 regarding the waste catalog (Journal of Laws of 2014 item 1923)</li> <li>• Regulation of the Minister of the Environment of 10 November 2015 on the list of waste types that a waste holder may provide to natural persons or organizational units that are not entrepreneurs, and acceptable methods of their recovery (Journal of Laws of 2016, item 93)</li> <li>• Regulation of the Minister of the Environment of 11 May 2015 on the recovery of waste outside installations and equipment (Journal of Laws 2015 item 798)</li> <li>• Regulation of the Minister of Economy and Labor of 5 October 2015 on the detailed ways of treatment of waste oils (Journal of Laws 2015 item 1694)</li> <li>• Act of 13 June 2013 on the management of packaging and packaging waste (Journal of Laws 2013, item 888)</li> <li>• Regulation of the Minister of the Environment regarding the permissible levels of electromagnetic fields in the environment and methods of checking compliance with these levels. (Journal of Laws 2003, No. 192, item 1883)</li> <li>• Act on the prohibition of the use of asbestos-containing products. (Journal of Laws 2017, item 2119)</li> </ul>	<p style="text-align: center;"><b>Waste: furnace waste, used sorbents, foils and packaging, filters, protective clothing, used mineral wool, used screen monitors, tires, oil, construction rubble, sand deposits, waste from sewage treatment plants, waste gypsum</b></p>

<ul style="list-style-type: none"> <li>• Regulation of the Minister of the Environment of 18 November 2014. on conditions to be met when introducing sewage into waters or into the ground, and on substances particularly harmful to the aquatic environment (Journal of Laws 2014, item 1800)</li> <li>• Integrated permit for fuel combustion installations</li> </ul>	<b>Water and effluents</b>
<ul style="list-style-type: none"> <li>• The Environmental Protection Law</li> <li>• Act on Energy Law (Journal of Laws 2018, item 755)</li> <li>• Act on Chemical Substances and Their Mixtures (Journal of Laws 2011, item 322)</li> <li>• Permission of the National Atomic Energy Agency to perform activities consisting of: turnover, transport, storage in the warehouse of isotope smoke detectors,</li> <li>• Regulation on the implementation of the 'Waste Management Manual'</li> <li>• Regulation of the Minister of the Environment of 19 November 2008 on the types of measurement results carried out in connection with the operation of an installation or device and other data and dates and ways of presenting them (Journal of Laws 2008, item 1366)</li> <li>• Introductory instruction on 'Manual for handling waste oils from devices supervised by the TNU Department'</li> <li>• Regulation on the implementation of 'Monitoring instructions for annual emission of carbon dioxide in a power plant for the purposes of the Community emission allowance trading scheme' with the addition of 'Methodology for determining carbon dioxide emissions from the use of carbonates in the Wet Waste Gas Desulphurisation (WWGD) system'</li> <li>• Act on public statistics of 29 June 1995 (Journal of Laws.2018, item997)</li> <li>• Regulation (EC) No. 1907/2006 concerning the Registration, Evaluation, Authorization and Restriction of Chemicals (RECH) and establishing a European Chemicals Agency</li> <li>• Regulation of the Minister of Energy of 9 June 2016 on granting public aid for investment projects aimed at improving energy efficiency under the Operational Program Infrastructure and Environment 2014-2020 (Journal of Laws 2016.poz.866)</li> <li>• Act of 3 October 2008 on access to information on the environment and its protection, public participation in environmental protection and environmental impact assessments (Journal of Laws 2008, No. 199, item 1227)</li> <li>• Regulation of the Minister of the Environment of 19 April 2018 on detailed conditions for granting regional public investment aid for environmental protection purposes (Journal of Laws 2018, item 787)</li> <li>• Act on maintaining cleanliness and order in communes (Journal of Laws1996, No. 132, item 622)</li> <li>• Regulation of the Minister of Economy and Labor on the way of labeling products, equipment and installations containing controlled substances, as well as containers containing these substances (Journal of Laws 2004 No. 195 item 2007)</li> </ul>	<b>Others</b>

The presented most important legal acts, contracts, permits and administrative decisions are obligatory or optional. Adapting to their requirements shows, on the one hand, care and responsibility towards the environment, and on the other, means realization of benefits of shareholders, creditors, clients, employees, the entire company and society.

#### **4. THE SCOPE AND IMPORTANCE OF ENVIRONMENTAL INFORMATION PRESENTED BY ENERGY SECTOR COMPANIES**

Analyzing environmental legal acts applicable to entities of the energy sector, it should be noted that they concern the creation of environmental information about the current state of the natural environment – this is mainly information on the size of pollutant emissions, resource management (water, sewage, other waste), and environmental information about plans related to environmental investments. A list of selected environmental reports prepared by energy sector enterprises resulting from obligatory legal regulations is presented in Table 2.

*Table following on the next page*

*Table 2: Obligatory, selected environmental reports prepared by energy sector entities (Own study based on selected statements, summaries, reports prepared by the examined entity)*

no	Report	Legal act	Other
1.	Report on the emission of air pollutants and on the state of cleaning devices	Act on Public Statistics	
2.	Report on the fractional analysis of dust emitted from the installation	Environmental Protection Law	
3.	Report on the management of water, sewage, pollution loads	Act on Public Statistics	
4.	Report on waste	Act on Public Statistics	Excluding municipal waste
5.	Summary of data on the types and amount of waste, on how to manage it and on installations and equipment used for recovery and disposal of waste	Act on Waste	
6.	Report on the core operations of the thermal power plant for 2016	Act on Public Statistics	
7.	Report on environmental impact	Environmental protection law, EIA procedure, Act on access to information about the environment and its protection	
8.	Report on the scope of using the environment, including the results of measurements of surface and underground water intake as well as the quantity and quality introduced	Environmental Protection Law	Data on the volume of pollutant emissions to air, data transferred in order to determine the amount of environmental charges
9.	Report on emissions measurements	Environmental Protection Law	
10	Report on fees for the use of the environment	Environmental Protection Law	Fees for: introduction of gases or dust into the air, effluent to water or soil, water intake, waste storage

Reports prepared by energy sector companies present non-financial information about the amount of water collected and purchased, sediments generated during the year, the amount of effluent discharged into water or into the ground, the amount of treated effluent, pollutant loads in effluent, quantities of waste generated by their types, and on ways of managing them and about installations and devices used for recovery and disposal of waste, the amount of fuels used and their origin. The report on the core power plant activity also presents quantitative and physical environmental information, and it concerns the amount of fuel used, including hard coal, heating oil, other solid fuels – biomass purchased domestically and abroad, the amount of flue gas emitted, emission limit values, etc. information on environmental costs is limited to fees and penalties for using the environment and costs of consumption of coal and other raw materials. Information on the predicted state of the natural environment is included mainly in reports on the environmental impact of planned projects, which constitute a comprehensive expertise on the effects of the planned investment on individual components of the natural environment. These reports contain a description of the environmental elements within the scope of the anticipated impact of the planned project during its construction, operation and decommissioning with possible cross-border environmental impact. The environmental information presented in the above reports is obtained primarily from ongoing environmental

monitoring and is of non-financial nature (information on the impact of the project on the quality of atmospheric air, land surface, water quality, landscape, people, animals, etc.). It should be noted that in the report on the scope of use of the environment and the report on emission measurements performed, apart from non-financial information, financial information pertains to – the amount of environmental fees charged for the introduction of gases or dusts into the air, collection of surface and groundwater, introduction of effluent into waters – at these quantities are determined on the basis of ongoing emission reports, a list of quantities and types of gases or dust entering the air, and a list containing information about the quantity and quality of surface and underground water taken, the quantity, condition and composition of effluent entering the waters. In these reports, information on fees and penalties for the use of the environment is presented by: emission to the atmosphere of dust, SO<sub>2</sub>, NO<sub>2</sub>, others, use of water, effluent disposal, waste storage, penalties broken down into air pollution, effluent disposal to waters and earth and others. The above information is obtained through the integrated SAP Information System. These data are originally collected from systems recording the emission of relevant substances into the atmosphere, and then properly converted into numerical data.

## 5. CONCLUSION

Presented environmental reports prepared by a energy sector company are obligatory, but there is also a second group of reports that the entity draws up, resulting from voluntary environmental management instruments and a third group of environmental management reports. They are prepared in relation to respecting individual principles of balanced and sustainable development – Corporate Social Responsibility (CSR) report, environmental costs report, etc. The number and scope of environmental reports and reports prepared by entities of the energy sector, required or recommended by ecological regulations, is high. Collecting and presenting environmental information required by environmental legislation is easier when there is a monitoring system of the entity's impact on the natural environment, as well as a well-functioning system for identifying, generating and presenting environmental reports. As the analysis carried out by the author of the paper showed, the environmental policy of the State exerts a huge influence on the environmental strategy of enterprise development, which is based on environmental management. Thanks to the implementation of this management model, which in the analyzed companies of the energy sector is conducted on the basis of a process management model, it is possible in these entities to efficiently generate comprehensive environmental information, mainly through environmental reports, contributing to:

1. Building a good reputation and trust in the company
2. Improving the image of the company and customer relations
3. 'Attracting' more effectively new investors and creditors
4. Efficient cost-benefit analysis of a pro-environmental development strategy
5. Estimating the effects of the impact on the environment and, as a consequence, limiting and rectifying of the adverse effects of the activity
6. Assessing compliance with legal provisions
7. Increasing opportunities for development and survival in a competitive world (Stępień, 2013, p. 286)
8. Increasing transparency of operations
9. Defining the strategy for the future development of the entity, in particular the strategy of corporate social responsibility.

Such a large number of positive features of generating and presenting environmental information stimulated by the state's environmental policy 'strengthens' the company's position in the turbulent and changing environment of the company.

## LITERATURE:

1. Górka K., Poskrobko B., Radecki W, (2001), Ochrona środowiska, PWE, Warszawa.
2. Górka K., Poskrobko B., Radecki W., (2001), Ochrona środowiska. Problemy społeczne, ekonomiczne i prawne, Warszawa.
3. Lisiecka K., Kubasik A., (2001), Środowisko w globalnej orientacji zarządzania przedsiębiorstwem, AE, Katowice.
4. Opałek K., (2007), Zagadnienia teorii prawa i teorii polityki. PWN, Warszawa.
5. Pakulska J., Rutkowska M., (2000), Cele i zasady polityki ekologicznej w Polsce i Unii Europejskiej. [w] Integracja Polski z Unią Europejską w dziedzinie ochrony środowiska red. M. Burchard-Dziubińska, Wyd. Biblioteka, Łódź.
6. Obwieszczenie Ministra Środowiska z dnia 15 października 2013 r. w sprawie ogłoszenia jednolitego tekstu rozporządzenia Ministra Środowiska w sprawie dopuszczalnych poziomów hałasu w środowisku. Dz. U. 2014, poz.112.
7. Rozporządzenie (WE) nr 1907/2006 w sprawie rejestracji, oceny, udzielania zezwoleń i stosowanych ograniczeń w zakresie chemikaliów (RECH) i ustanawiające Europejską Agencję Chemikaliów.
8. Rozporządzenie Komisji (UE) 2015/830 z dnia 28 maja 2015 r. zmieniające rozporządzenie (WE) nr 1907/2006 Parlamentu Europejskiego i Rady w sprawie rejestracji, oceny, udzielania zezwoleń i stosowanych ograniczeń w zakresie chemikaliów (REACH).
9. Rozporządzenie Ministra Energii z dnia 9 czerwca 2016 r. w sprawie udzielania pomocy publicznej na projekty inwestycyjne służące poprawie efektywności energetycznej w ramach Programu Operacyjnego Infrastruktura i Środowisko 2014–2020. Dz.U.2016, poz.866.
10. Rozporządzenie Ministra Gospodarki i Pracy w sprawie sposobu oznakowania produktów, urządzeń i instalacji zawierających substancje kontrolowane, a także pojemników zawierających te substancje. Dz.U. 2004 nr 195 poz. 2007.
11. Rozporządzenie Ministra Gospodarki i Pracy z dnia 5 października 2015 r. w sprawie szczegółowego sposobu postępowania z olejami odpadowymi. Dz.U. 2015, poz. 1694.
12. Rozporządzenie Ministra Środowiska w sprawie dopuszczalnych poziomów pól elektromagnetycznych w środowisku oraz sposobów sprawdzania dotrzymania tych poziomów. Dz.U. 2003, nr 192, poz. 1883.
13. Rozporządzenie Ministra Środowiska z dnia 1 marca 2018 w sprawie standardów emisyjnych dla niektórych rodzajów instalacji, źródeł spalania paliw oraz urządzeń spalania lub współspalania odpadów. Dz.U. 2018, poz. 680.
14. Rozporządzenie Ministra Środowiska w sprawie wymagań w zakresie prowadzenia pomiarów wielkości emisji. Dz.U. 2018, poz. 1022.
15. Rozporządzenie Ministra Środowiska z 09 grudnia 2014 r. w sprawie katalogu odpadów. Dz.U. 2014, poz. 1923.
16. Rozporządzenie Ministra Środowiska z dnia 11 maja 2015 r. w sprawie odzysku odpadów poza instalacjami i urządzeniami. Dz.U. 2015, poz. 798.
17. Rozporządzenie Ministra Środowiska z dnia 12 września 2008 r. w sprawie sposobu monitorowania wielkości emisji substancji objętych wspólnotowym systemem handlu uprawnieniami do emisji. Dz. U. 2008, nr 183, poz. 1142.
18. Rozporządzenie Ministra Środowiska z dnia 6 czerwca 2018 r. w sprawie zakresu i sposobu przekazywania informacji dotyczących zanieczyszczenia powietrza. Dz.U. 2018, poz. 1122.
19. Rozporządzenie Ministra Środowiska z dnia 19 listopada 2008 r. w sprawie rodzajów wyników pomiarów prowadzonych w związku z eksploatacją instalacji lub urządzenia i innych danych oraz terminów i sposobów ich prezentacji. Dz.U. 2008, nr 215, poz. 1366.

20. Rozporządzenie Ministra Środowiska z dnia 27 września 2011 r. w sprawie procentowego udziału uprawnień do emisji, jakie w okresie rozliczeniowym rozpoczynającym się od dnia 1 stycznia 2013 r. mogą zostać przyznane instalacjom objętym systemem handlu uprawnieniami do emisji gazów cieplarnianych. Dz. U. 2011, nr 203, poz.1194.
21. Rozporządzenie Ministra Środowiska z dnia 19 kwietnia 2018 r. w sprawie szczegółowych warunków udzielania regionalnej pomocy publicznej inwestycyjnej na cele z zakresu ochrony środowiska. Dz. U. 2018, poz.787.
22. Rozporządzenie Rady Ministrów w sprawie przypadków, w których działalność związana z narażeniem na promieniowanie jonizujące nie podlega obowiązkowi uzyskania zezwolenia albo zgłoszenia oraz przypadków, w których może być wykonywana na podstawie zgłoszenia. Dz.U. 2004, nr 98, poz. 980.
23. Ustawa o utrzymaniu czystości i porządku w gminach. Dz.U. 1996, nr 132, poz. 622.
24. Ustawa o statystyce publicznej z 29 czerwca 1995. Dz.U.2018, poz. 997.
25. Ustawa o substancjach chemicznych i ich mieszaninach (Dz.U. 2011, poz. 322)
26. Ustawa o zakazie stosowania wyrobów zawierających azbest. Dz.U. 2017, poz. 2119.
27. Ustawa Prawo energetyczne. Dz.U. 2018, poz. 755.
28. Ustawa z dnia 11 maja 2001r. o obowiązkach przedsiębiorców w zakresie gospodarowania niektórymi odpadami oraz o opłacie produktowej. Dz. U. 2018, poz. 1932.
29. Ustawa z dnia 12 czerwca 2015 r. o systemie handlu uprawnieniami do emisji gazów cieplarnianych. Dz.U. 2015, poz. 1223.
30. Ustawa z dnia 13 czerwca 2013 r. o gospodarce opakowaniami i odpadami opakowaniowymi. Dz.U. 2013, poz. 888.
31. Ustawa z dnia 14 grudnia 2012 r. o odpadach. Dz.U. 2018, poz. 1592.
32. Ustawa z dnia 20 lipca 2017r. - Prawo wodne. Dz.U. 2017, poz.1722.
33. Ustawa z dnia 20 lutego 2015 r. o odnawialnych źródłach energii. Dz. U. 2015, poz. 478.
34. Ustawa z dnia 27 kwietnia 2001r. Prawo ochrony środowiska. Dz.U. 2018, poz. 1722.
35. Ustawa z dnia 3 października 2008 r. o udostępnianiu informacji o środowisku i jego ochronie, udziale społeczeństwa w ochronie środowiska oraz o ocenach oddziaływania na środowisko. Dz.U. 2008, nr 199 poz. 1227

## FORECASTING THE DEVELOPMENT INDICATORS OF MECHANICAL ENGINEERING IN RUSSIA

**Yuliya V. Razvadovskaya**

*Research Center "Instrumental, Mathematical and Intellectual Support of Economy" (IMISE)  
Southern Federal University, Rostov-on-Don, Russia  
yuliyaraz@yandex.ru*

**Anton A. Afanasyev**

*Research Center "Instrumental, Mathematical and Intellectual Support of Economy" (IMISE)  
Southern Federal University, Rostov-on-Don, Russia  
afanasyevanton@sfedu.ru*

**Inna K. Shevchenko**

*Research Center "Instrumental, Mathematical and Intellectual Support of Economy" (IMISE)  
Southern Federal University, Rostov-on-Don, Russia  
ikshevchenko@sfedu.ru*

**Anna V. Khanina**

*Department of management and innovation technologies  
Southern Federal University, Rostov-on-Don, Russia  
ahanina@sfedu.ru*

**Ekaterina V. Kaplyuk**

*Research Center "Instrumental, Mathematical and Intellectual Support of Economy" (IMISE)  
Southern Federal University, Rostov-on-Don, Russia  
evkaplyuk@sfedu.ru*

**Anna A. Marchenko**

*Research Center "Instrumental, Mathematical and Intellectual Support of Economy" (IMISE)  
Southern Federal University, Rostov-on-Don, Russia  
aamarchenko@sfedu.ru*

### ABSTRACT

*Structural approach to economic development represents a radical transformation of the production structure of the economy in terms of increasing the complexity of production and increasing labor productivity. In this regard, the development of the mechanical engineering for the national economy is important in terms of increasing labor productivity through the growth of mechanization and automation of production. This paper provides an overview of the main trends in the development of the mechanical engineering in Russia, including availability of state programs for modernization of the industry. To forecast the parameters of the development of the mechanical engineering market, we use the model of interspecies interaction Lotka-Volterra. Such choice in this study is due to its ability to predict the parameters of interaction between market participants taking into account the change in ownership. The findings of the study show that large-scale projects of public-private partnerships and/or joint joint ventures and foreign enterprises may determine the key trends and main growth directions of industrial enterprises.*

**Keywords:** *Innovation potential, mechanical engineering, form of ownership, Lotka-Volterra, Russia*



## **1. INTRODUCTION**

Mechanical engineering reflects and largely determines the technical level of all branches of the national economy, being a supplier of fixed capital, namely its active elements. In the process of innovative development of the economy, the mechanical engineering complex plays a key role in ensuring the technological level of production. Analysis of the structure, the main changes, as well as the forecasting the proportions of the mechanical engineering in the Russian economy in the process of developing innovative capacity is particularly interesting and complex. Since many factors contributed to the development of mechanical engineering in the Russian economy, its structure was controversial. On the one hand, the development of the Russian economy was accompanied by profound structural changes associated with the diminishing role of the manufacturing industry, and with another transformation of property relations to industrial resources. As a result of the internal transformations that have taken place, as well as the universal patterns of scientific and technological development, the mechanical engineering has fallen out of the focus of state industrial policy, as well as investment interests of economic entities. In this article, we attempt to analyze and simulate the dynamics of the development of enterprises of the mechanical engineering from the point of view of the transformation of ownership forms into the capital of these companies. In the first part, we analyze the theoretical foundations in the sphere of changing ownership of resources and productivity. The second part provides an overview of the development of mechanical engineering in the Russian economy. Further, modeling of the process of transformation of ownership forms using the Lotka-Volterra model is presented. The final part discusses the results obtained and draws conclusions.

## **2. THEORY AND HYPOTHESES**

The process of innovative development of the economy is determined by a variety of factors. Among such factors, M. Porter highlights the following: 1. Conditions for factors. The country's position in the factors of production, such as the availability of skilled labor or infrastructure, necessary to compete in the industry. 2. The state of demand. The nature of demand in the domestic market for an industrial product or services. 3. Related and supporting industries. Presence or absence in the given country of branches-suppliers or other accompanying branches, competitive internationally. 4. Stable strategy, structure and rivalry. Existing conditions in the country for the creation, organization and management of companies, as well as the nature of internal competition. From this point of view, the mechanical engineering can be considered as the main (from the point of view of the production of new final goods for consumers) and the supporting industry (in terms of producing improved active elements of fixed capital). In the process of innovative development, mechanical engineering products are the main element of automation and mechanization of production processes and serve as the main condition for increasing the competitiveness of medium-tech sectors. An important condition and factor of innovative development are property relations, which at every stage of the world economy development take a form characteristic of the technological level of production. If during the period of early industrialization, the predominant form of organization of production were large manufactory of private ownership, a more acceptable form of transnational corporations are mixed ownership for the current stage of globalization. That is, an important factor in the development of the industry and opportunities for the production of innovations is both cooperation between the public and private sectors, and interaction with foreign companies. In this regard, we assume that improving the efficiency of companies in the field of mechanical engineering will be associated with a change in ownership, namely the development of mixed forms of ownership. As noted above, to predict the parameters of the development of the mechanical engineering market, we use the model of interspecies interaction Lotka-Volterra. This choice in this study is due to its ability to predict

the parameters of interaction between market participants taking into account the change in ownership. The model was proposed in 1925 by A. Lotka (Lotka A.J. 1925), and independently, in 1926, by V. Volterra (Volterra V., 1976). The Lotka-Volterra model was originally applied in the field of mathematical ecology, specifically for modeling the interspecies interaction of biological populations, but later became widely used in the field of economics. The Lotka-Volterra model is used to predict the main environmental trends. For example, I.R. Geijzendorffer, W. Van der Werf, F.J.J.A. Bianchi used the model to predict long-term trends in the development of meadow species of crops under the influence of external threats (I.R. Geijzendorffer, W. Van der Werf, F.J.J.A. Bianchi, 2011). In order to analyze the dynamics of biodiversity L. Roques, M. Chekroun investigated the competition of several species using the Lotka-Volterra model, and estimated the degree of chaos and risk in the biosphere. Outside the field of biology and ecology, the Lotka-Volterra model is widely used to analyze competitive behavior in the market. For example, S.J. Lee, D.J. Lee, H.S. investigated the trading values of two Korean stock exchanges, the Korean stock exchange and securities dealers, predicted trends in the development of selected objects through this model (S.J. Lee, D.J. Lee, H.S., 2005). J. Kim, D.J. Lee, J. Ahn, using the Lotka-Volterra model, investigated the dynamics of the development of the Korean mobile phone market (J. Kim, D.J. Lee, J. Ahn, 2006). V.B. Kreng, H.T. Wang used the Lotka-Volterra model to research competitive interaction of the liquid crystal and plasma displays market in Taiwan, which allowed them to determine the dynamics of the development of these markets and determine the equilibrium parameters (V.B. Kreng, H.T. Wang, 2011). C. Lin using the theory of systems predicted the parameters of mobile communication in Taiwan, and then applying the Lotka-Volterra model determined the basic conditions of competitive relations in this market (C. Lin, 2013). Using the improved Lotka-Volterra model H.B. Duan, L. Zhu, Y. Fan studied the evolution of wind energy and solar energy technologies, and the dissemination of these technologies in the world (H.B. Duan, L. Zhu, Y. Fan, 2013). Thus, wide application of this model allows us to consider it as a tool for drawing up forecasts of the capacity of the engineering market taking into account the specific nature of the form of ownership of the enterprises under study. We assume that in the forecast period the share of the market of enterprises with a share of state property, as well as enterprises of mixed ownership, will increase. This assumption is due to the fact that the current trends in the development of strategically-oriented industries, namely, investment goods in the world economy, are mainly associated with the formation of large multinational corporations of mixed ownership.

### **3. MECHANICAL ENGINEERING IN RUSSIA**

The structure of the Russian economy was formed in such a way that the mechanical engineering complex functions as the technological core of the industrial sector. Such important macroeconomic indicators as the level of labor productivity, material consumption and energy intensity of production all depend on the level of development of engineering industry. Currently, the list of the largest companies includes 22 enterprises, 11 of which are private (Fig. 1).

*Figure following on the next page*

Figure 1: Distribution map of mechanical engineering enterprises by forms of ownership



The development of mechanical engineering enterprises in the Russian economy is associated with a number of characteristic features: low profitability, high wear and tear of equipment, low investment attractiveness. Against the background of the above problems, extremely low rates of innovation of the industry companies are observed. The costs of technological innovation despite the positive dynamics in the period from 2010 to 2015 remain critically low (Table 1). Enterprises of mechanical engineering basically have low rates of capital productivity, high level of specialization, and are also characterized by the need for high-tech expensive equipment and highly qualified personnel.

Table 1: The main characteristics of the type of economic activity "Production of machinery and equipment" (Industrial production in Russia. 2016)

Index	2010	2011	2012	2013	2014	2015
Number of firms in the industry, pcs.	44630	43898	43729	42528	42348	43163
Profit, %	111,7	113,9	125,0	102,5	85,2	121,0
The share of organizations that carried out technological innovations in the total number of organizations surveyed, %	14,8	15,3	14,8	14,9	14,6	12,9
The volume of shipped innovative goods, works, services, million rub.	47272,7	58384,1	62289,4	68797,0	56181,6	56552,2
Costs for technological innovation, mln. Rub.	10639,5	11740,9	12280,5	14642,7	19241,1	18012
Average annual number of employees of organizations in the industry, thousand people.	649,5	639,1	623,8	592,4	547	511,4

The solution of the problems of the mechanical engineering is planned to be provided both by stimulating the investment activity of the private sector, developing public-private partnership projects, and at the expense of direct state support of the companies. For this purpose, at the federal level, programs are being developed to support the mechanical engineering as a whole and individual industries. In accordance with the state program "Development of Industry and Enhancing Its Competitiveness" of April 15, 2014 (Decree of the Government of the Russian Federation of April 15, 2014), the efforts of the state are aimed at outstripping the creation of innovative infrastructure for the development of new industries, the removal of regulatory barriers and the formation of parity conditions for bringing innovative products to the market. With regard to industries oriented to investment demand, the main tasks are: renewal of the technological base, stimulation of research and development, increase of competitiveness and increase in the share of exports and the share of domestic machinery and equipment in the

domestic market. This state program includes the following branches related to the sphere of engineering: agricultural machinery, mechanical engineering for the food and processing industry; mechanical engineering for light industry, mechanical engineering of specialized industries (road construction and municipal engineering, fire, airfield, forestry equipment); transport engineering; machine-tool industry; heavy engineering; electrical power engineering and power engineering. The volume of appropriations in accordance with the subprogram of industrial development for the transport and special mechanical engineering industry (Passport of subprogram 1 "Development of transport and special mechanical engineering ", 2014) provides for funding of 861,836,768.7 thousand rubles from the federal budget; the production development subprogram provides financing in the amount of 60,956,964.1 thousand rubles (Passport of subprogramme 2 Development of production of means of production Decree of the Government of the Russian Federation, 2014). According to the website of the Ministry of Industry and Trade, in order to stimulate the development of the mechanical engineering, programs are envisaged that include full or partial compensation of costs for the purchase of equipment and machinery of domestic production, compensation of costs associated with the export of goods, compensation of costs of credit institutions associated with the application of a reduced interest rate for the organizations of the mechanical engineering complex. In aggregate, according to the website of the Ministry of Industry and Trade (<https://gisp.gov.ru/support-measures/>) there are 219 programs, including 39 programs that provide financial support at the federal level. Despite the existence of state support programs, the industry is experiencing problems related to the availability of investments and qualified personnel.

#### 4. MODELING

To predict the parameters under study, namely the market capacity of the mechanical engineering, taking into account the form of ownership, the Lotka-Volterra model of interspecies interaction was used, by adapting the classical equations:

$$\begin{aligned}\frac{dN_1}{dt} &= X + t * (-b * X + k * X * Y) \\ \frac{dN_2}{dt} &= Y + t * (a * Y + k * X * Y)\end{aligned}\quad (1)$$

Where, X is the capacity of the market, a private form of property attributed to predators;  
Y - The capacity of the market, by forms of property attributed to the victims;  
a – the coefficient of reproduction of predators in the classical model, while adapting the forecast values of the rate of return for the form of ownership under study;  
b – the reproduction ratio of victims in the classical model, while adapting the forecasted values of the rate of return for the form of ownership under study;  
k – the nutritional factor calculated on the basis of statistical data, and denoting the value of the changed forms of ownership of the private;  
t – time interval.

The Modeling was carried out on the basis of the dynamic data of PJSC "Moscow Exchange" on quotations and tradable objects of the 26 largest enterprises of mechanical engineering industry with the volume of trades of 4897692904.58 rubles. The list of companies is presented in Appendix 1. The modeling was carried out according to the following options:

- Option 1: Private property (predator, X) - joint federal and foreign property (victim, Y).
- Option 2: Private property (predator, X) - Joint private and foreign ownership (victim, Y).
- Option 3: Private property (predator, X) - other mixed Russian property (victim, Y).

- Option 4: Private property (predator, X) - mixed Russian property with a share of federal property (victim, Y).

The initial data for forecasting the capacity of the engineering industry by the types of property under study are presented in Table 2.

Table 2: Baseline data for forecasting the market capacity of the mechanical engineering according to the Lotka-Volterra model

Symbol	The numerical value			
	Option 1	Option 2	Option 3	Option 4
X	2228503162,51	2228503162,51	2228503162,51	2228503162,51
Y	1404294141,3	157279155,0	357843094,19	357843094,19
A	1,13	1,13	1,14	1,14
B	1,1	1,12	1,1	1,1
K	0,000002	0,000002	0,000002	0,000002
T	1 year	1 year	1 year	1 year

## 5. RESULTS

As a result of the calculations, we obtained data that indicate an increase in the market capacity indicators of enterprises of mixed ownership in the forecast period. By recursive solution of the system of equations (1), we obtain the forecast value of the market capacity of the mechanical engineering by private, joint federal and foreign ownership (Figure 2-5).

Figure 2: The forecast value of market capacity of the mechanical engineering by private and joint federal and foreign forms of ownership

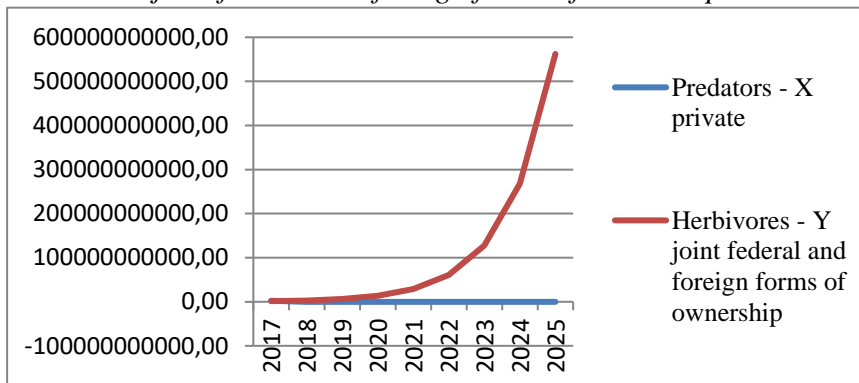

Figure 3: The forecast value of market capacity of mechanical engineering by private and joint private and foreign ownership

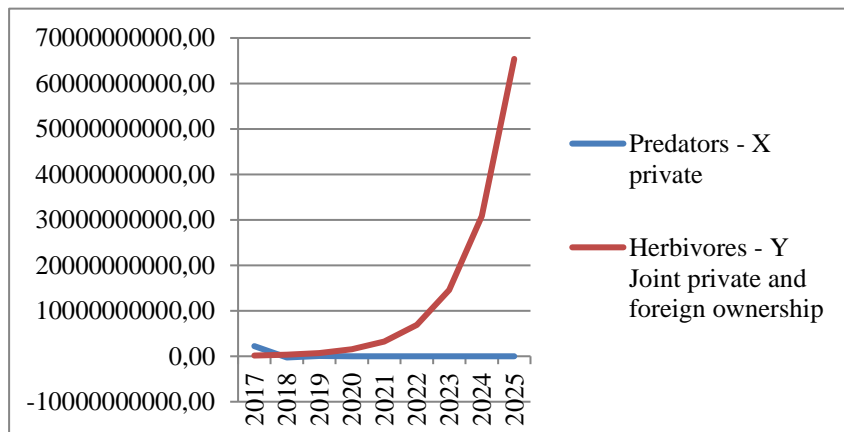

Figure 4: The forecast value of market capacity of the mechanical engineering for private and joint private and other mixed Russian property

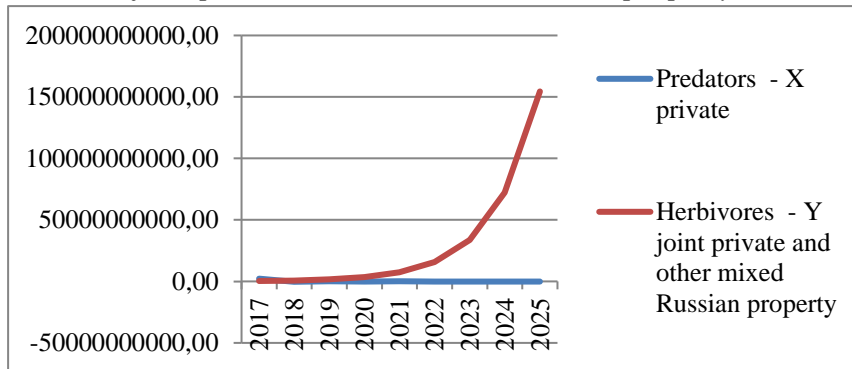
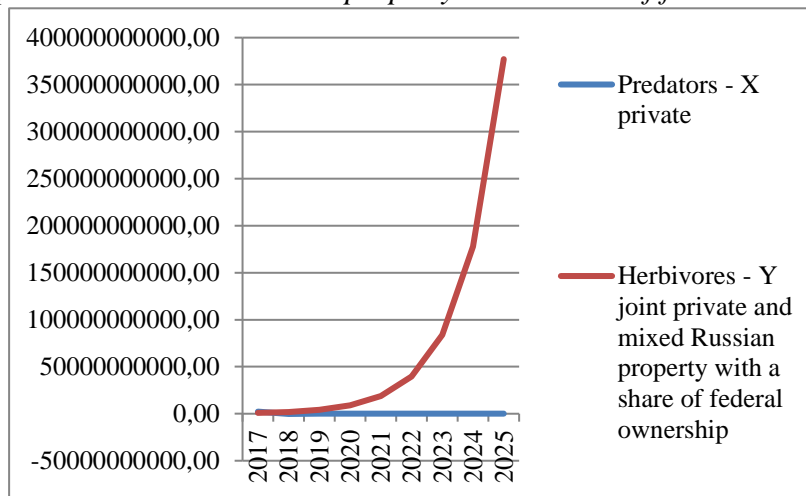

Figure 5: The forecast value of market capacity of the mechanical engineering for private and joint private and mixed Russian property with a share of federal ownership



The growth in the output of mechanical engineering on the one hand is a positive fact, however on the other hand it does not indicate an increase in the competitiveness of the enterprises of the industry. In most cases, the growth in production volumes is due to its simplification and adaptation to secondary market niches. Thus, small and medium-sized enterprises of the industry generate a large share of profits through the provision of services, including service control. This is because it is becoming increasingly difficult for Russian enterprises to compete with the products of Chinese companies that are cheaper to manufacture. Secondly, high wear of existing equipment leads to problems associated with the quality of products. The current passive trends in the investment and innovation sphere that are observed in the Russian mechanical engineering are impossible without large-scale long-term projects, which under current conditions can only be applied to large state-owned companies or transnational corporations.

## 6. CONCLUSION

The analysis and modeling of trends in the engineering market make has shown that large-scale projects of public-private partnership and/or joint Russian-foreign enterprises can become the main options for the development of enterprises working in this area. Despite the fact that at present the majority of enterprises in the industry are private, positive trends in the future are demonstrated by enterprises of mixed ownership. According to the Russian Expert-400 rating, the top 50 Russian companies include 3 engineering companies, two of which are state-owned and one with foreign participation (Table 3).

Table 3: Rating of the enterprises of mechanical engineering according to Expert 400 for 2017

№ in the rating	Company name	Type of ownership	Sales volume (million rubles)	Profit before taxation (million rubles)
23	United Aircraft Corporation	Federal property	416 926,0	- 5 078,0
39	United Shipbuilding Corporation	Federal property	301 940,0	8 222,0
43	Toyota Motor	Property of foreign legal entities	277 539,0	5 750,0
56	Russian Helicopters	Private property	214 360,0	24 876,0
57	Concern Almaz-Antey	Federal property	212 439,0	1 381,0
62	Volkswagen Group Rus	C Property of foreign legal entities	191 108,0	- 5 590,0
63	United Engine Corporation	Private property	189 579,0	23 085,0
66	AvtoVAZ Group	Joint ownership of the subjects of the Russian Federation and foreign ownership	184 931,0	- 48 057,0
80	GAZ Group	Private property	150 196,9	2 189,2
83	Autotor Holding	Private property	149 000,0	N/A

In the first case, the creation of joint ventures with state participation will contribute to the development of medium and long-term investment and innovation programs in the industry. This practice is common in many countries, where the private sector cannot provide financing for major investment modernization projects. In the second case, the creation of large Russian-foreign companies will contribute to the emergence of effects from foreign direct investment. Foreign investments allow enterprises to purchase new technologies, however, domestic companies may suffer from negative effects, including a decrease in the market share of local enterprises in the industry, and the loss of qualified personnel. Nevertheless, according to the UN (2001), the positive effect of foreign competition exceeds the negative effects in most cases (World Investment Report 2001). Modernization of enterprises is possible through borrowing new technologies in developed countries. Enterprises of the host country receive new technologies through transnational corporations, since it is difficult to obtain new technologies in any other way<sup>1</sup>. The spread of technology leads to an increase in the productivity of enterprises of the host country (Caves, Richard E., 1999). In general, it should be noted that at the current stage of the development of the Russian economy, bearing in mind restricted access to foreign capital, state support will be the most important condition for the growth of innovation for engineering companies.

<sup>1</sup> Caves, Richard E. (1999) *Multinational Enterprise and Economic Analysis*, second ed. Cambridge Univ. Press, Cambridge.

We assume that in the medium term, the most successful companies will be public sector companies that have state guarantees, and the possibility of using state capital. The calculations carried out using the Lotka-Volterra model confirm our assumptions.

**ACKNOWLEDGEMENT:** *The study was carried out with the financial support of the Russian Foundation for Basic Research in the framework of the scientific project No. 16-29-12995 "Modeling and forecasting the dynamics of the development of the innovative potential of the national economy."*

**LITERATURE:**

1. Caves, Richard E. (1999) *Multinational Enterprise and Economic Analysis*, second ed. Cambridge Univ. Press, Cambridge.
2. Decree of the Government of the Russian Federation of April 15, 2014. No. 328 (as amended on 30.03.2018) "Development of industry and increase of its competitiveness".
3. Duan H.B., Zhu L., Fan Y. A (2013) A cross-country study on the relationship between diffusion of wind and photovoltaic solar technology *Technological Forecasting & Social Change* 10.1016/j.techfore.2013.07.005.
4. Finance of Russia. 2016: STAT.SB./ROSSTAT. - M., 2016. - 343 P.
5. Geijzendorffer I.R., Van der Werf W., Bianchi F.J.J.A., (2011) Schulte R.P.O. Sustained dynamic transience in a Lotka–Volterra competition model system for grassland species *Ecological Modelling*, 222, pp. 2817-2824.
6. Industrial production in Russia. 2016: STAT.SB./ROSSTAT. - M., 2016. - 347 P.
7. Jones, Derek C. Klinedienst, Mark, Rock, Charles. (1998) Productive efficiency during transition: evidence from Bulgarian panel data. // *Journal of Comparative Economics*. 26 (3), 446–464.
8. Kim J., Lee D.J., Ahn J. (2006) A dynamic competition analysis on the Korean mobile phone market using competitive diffusion model *Computers & Industrial Engineering*, 51, pp. 174
9. Kreng V.B., Wang H.T. (2011) The competition and equilibrium analysis of LCD TV and PDP TV *Technological Forecasting & Social Change*, 78, pp. 448-457.
10. Lee S.J., Lee D.J., Oh H.S. (2005) Technological forecasting at the Korean stock market: A dynamic competition analysis using Lotka–Volterra model *Technological Forecasting & Social Change*, 72, pp. 1044.
11. Lotka A.J. *Elements of Physical Biology*. 1925.
12. Passport of subprogram 1 "Development of transport and special machine engineering" Decree of the Government of the Russian Federation of April 15, 2014 N 328 Resolution of the Government of the Russian Federation of April 15, 2014. No. 328 (as amended on 30.03.2018) "Development of industry and increase of its competitiveness".
13. Passport of subprogramme 2 Development of production of means of production Decree of the Government of the Russian Federation of April 15, 2014 N 328. United Nations, (2001) *World Investment Report 2001*. United Nations, Geneva.
14. Volterra V. (1976) *Mathematical theory of fight against existence*. M.: Science



## EFFECTIVE WAYS TO COMMUNICATE ENTREPRENEURSHIP CONCEPTS TO MOROCCAN MILLENIALS

**Houda Jorio**

*Professor, IIHEM, Morocco  
hjorio@iihem.ac.ma*

**Samira Kasmi**

*Professor, University Mohamed V, Morocco  
samira.kasmi@gmail.com*

**Mustapha Machrafi**

*Professor, University Mohamed V, Morocco  
mustapha.machrafi@gmail.com*

### **ABSTRACT**

*Entrepreneurship, as a course, is a debatable issue. As a discipline, there exist lots of ways and or methods of evaluating the level of students' success. It is one of the newest disciplines assigned in many fields not only in business schools. There is an on-going debate in the entrepreneurship academy about whether it can actually be taught and when it is the case, is it an art or a science? Its resolution is connected with some theoretical assumptions because they affect how and what is taught within Entrepreneurship.*

**Keywords:** *Entrepreneurship, business plans, venture, learning by doing, pitching*

### **1. INTRODUCTION**

As a discipline, entrepreneurship has always been a subject of arguments, should it be taught or not? If yes, is there enough research to back it up? If not, how would the new generations establish a foundation of knowledge about this contemporary field of study? There are and will always be lots of arguments into the above. It is unsurprising that the development, and indeed the pervasion, of Entrepreneurship as a course have attracted academic interest. Since the 1980s the number of entrepreneurship courses available to students has been increasing but this raises issues of what precisely we expect to be the outcome of our efforts [1]. Can we possibly satisfy all these different expectations? Indeed, is this an appropriate role for academic institutions? Entrepreneurship is not new, however, compared to other disciplines it is. During the past number of years it has gained increased interest and research. This increased interest has emerged for a number of reasons, namely the recognition of the contribution of the small firm sector to economic development and job creation. Much of the economy's, ability to innovate, diversify, and create new jobs comes from the small business sector. Other reasons are mainly related to the diversified fields of study of today's higher level education, the absolute need of the millennials to independent lifestyles, and the awareness of young adults to make a difference, without forgetting the fact that there is a great shift of today's economy to service industry. The urgency of the entrepreneurship education has given birth to the startup era. Building the culture of entrepreneurship has become the ultimate objective for most nations' young generations. In fact, it is also a sign of development, the reason why startups could be born in uncivilized, non-educated, and poor countries and target the complete opposite, highly developed and emerging big industries. Within this work, my aim is summed up into two main parts: the first one is to clarify via some more refined and cumulative theory different methods on how and what to teach to students in Entrepreneurship course. The second one is to build in the entrepreneurship mindset through "learning by doing", which is the key to succeed and

master not only the course but also the practical side of this discipline, summarized in a crucial document called “business plan”.

## **2. ENTREPRENEURSHIP RESEARCH**

### **2.1. Entrepreneurship theories**

As I have mentioned in my introduction, Entrepreneurship is one of the newest disciplines considered to be taught not only in business schools but in other majors and academic careers, as well. It is until 1940 that this field of study has seen the light of research. All the researchers have developed theories based on their own perceptions which make it clear that entrepreneurship in itself is start up and its theories are in their growth phase and that gives more space for the new generation of entrepreneurs, scholars, and researchers to build new theories based on their life living experiences [2]. Entrepreneurship course is a cumulative one, the last course to be taught simply because it gathers the entire previous learned subjects. The reason behind Entrepreneurship being cumulative is because it groups all previously learned theories and also it is a pure application of the major theory of “learning by doing”. It comes also at a time to prove that the student has reached a certain maturity level in which he/she can think rationally and develop a detailed analysis on how to connect his business venture to his environment, a challenging process. The theories involved within this field of knowledge are varied, among them are:

#### *2.1.1. The sociological theory*

Stating that entrepreneurship is likely to get a boost in a particular social culture, in which the individual’s behavior could positively influence a society’s values, beliefs, cultures, customs, and taboos. That is linked to the fact that the entrepreneur himself is the role performer according to the roles expected by the society. As a result, this answers one of the most confusing questions about Entrepreneurship being an art or science, since there exist a great emphasis on sociology and individuals’ behavior, at this point, one could evaluate it as an art. Within this measure, comes the organizational behavior which is the process of evaluating how individuals behave toward themselves, others, the society, and the imposed legal and political environments. This is a discipline that gathers lots of theories and social sciences.

#### *2.1.2. The psychological theory*

As being part of the organizational behavior stated above, entrepreneurship is heavily tied up to how people behave as individuals, here comes the call for a self-evaluation survey, personality testing, and observer rating. One major part of teaching this discipline is to establish a mindset; this cannot be achieved without having to analyze the potential business creator’s personality, values, attitudes, and social skills. The theory of planned behavior (TPB) is most appropriate to be the theoretical basis of entrepreneurship’s mindset building process because it provides most information about the conception process of entrepreneurial intention at both personal and social level [3]. Further, entrepreneurship is a planned behavior that a new business is seldom created suddenly without planning, and thus it is best predicted by entrepreneurial intention. The so called (TPB) theory is applied to compare and study the relationship between entrepreneurship students and control group students, testing the effect of specific education components on entrepreneurial intention, and exploring the results from the theoretical and practical perspectives. Based on the (TPB) and elaboration of entrepreneurship education into different components, a comprehensive analysis is to be developed. Entrepreneurship also gets a boost when society has sufficient supply of individuals with necessary psychological characteristics which include need for high achievement, a drive, a risk taking mind, a vision, and the ability to face opposition. The list is long and will be developed as we progress in this framework.

The characteristics are formed during the individual's upbringing which stress on standards of excellence, self-reliance, and low father dominance. Within this theory, comes also the achievement motivation theory that suggests that there exist two needs among the highest level on the Maslow's hierarchy of needs, the first one is self-actualization; this later is not achieved unless the individual gets to the point of having to improve his self-existence by fulfilling his full potential. The second one is self-esteem, which is the level at which the individual is respected by others and is motivated by an increase of his own esteem. It is the point of time at which the person feels a sense of self admiration. Maslow identified self-actualizing people as individuals who are highly creative, who have peak experiences, and who are able to resolve the dichotomies inherent in opposite contraries such as those constituted by "freedom and determination", "the conscious and the unconscious", as well as "intentionality and a lack of intentionality." Creativity, a hallmark of a self-actualizing person, may be perceived to reside within a dialectical relationship. While most dichotomies cannot be explicitly understood as resolvable, the above dichotomies can be seen to be resolved through creative activity. Using the one aspect of each of these dichotomies as a "thesis", and another as an "antithesis", art may represent the "synthesis" of the dichotomous relationship [4].

#### *2.1.3. The Entrepreneurship Innovation theory*

This theory is developed by Joseph Schumpeter in which he believes that the entrepreneur helps the process of development of an economy, he adds that he is the source of innovation, creativity, and foresight. According to him, innovation occurs when the entrepreneur introduces a new product, a new process, or a new organization in any industry. He also adds that an entrepreneur's mission is to find out a new market and a new source of supply. For him, an entrepreneur is a role model to imitate in a society rather than to follow on an existing strategy [5]. Within this framework, the entrepreneur is ought to see success not only in profits more than the innovation on how to achieve profit. It stands also on the basis that the entrepreneur has to understand the difference between innovation and invention. An entrepreneur, under this theory, is more of a leader than an owner. He is to focus on continuous improvement to build the mindset of a serial entrepreneur rather than a onetime business venture builder. Schumpeter's theory suggests also that the entrepreneur has to be creative and creativity is drawn from three main points. The first one is from a personal story, an entrepreneur has to invest in something he loves and of which he could build a lifelong connection. The second one is drawn from the processing of the personal story into the brain to create a mindset, and the last one compiles a set of activities to merge the personal story with the mindset. The third one comes from the perseverance that the entrepreneur holds as one who is able not only to understand the risks undertaken but also cope with potential threats to come on the way. The entire three combined make a great unique value which ends up drawing the innovation line within the entrepreneur's thought and ends up making his business venture unique [6].

#### *2.1.4. Risk bearing theory*

This latter is suggested by Knights. He has based his theory on economic principles implying that an entrepreneur is a risk taker, profit and risks taking for him are interdependent. One cannot happen without the other, in other words, the higher the risk the higher the profits. However, to some degree there should some controllable factors of the risks. This is effective when the entrepreneur is good at anticipating the future via forecasting models [7]. Uncertainty bearing is essential to production, it is factor of production and the reward of it is a part of normal cost and the profit is a payment for the assumption of risks the entrepreneur undertakes. Knights' theory states that success is heavily tied up to challenges and uncertainties. At the point of time when doubts are escalating on the entrepreneur's mind, there is a great call for anticipation of future outcomes of "what ifs".

This, in fact, is a call of a deeper thought that goes hand in hand with innovation since it does not stop at thoughts but could extend itself into actions. Knights' theory also suggests that the entrepreneur in the ideal owner-managed firm is providing guarantees to the workers. But Knight is just as clear that the guaranteeing function is not necessary to entrepreneurship, and is in fact separable from it. As a result, the more the risk he is seeing, the greater he is at diminishing its effects in front of his employees and coworkers, and by doing so; he is a motivator and a positive influencer. Within the managerial framework, there are numerous theories which are all applied at the entrepreneurship process but at different levels. The reason behind this field being a pure application of the learning process in all areas, bringing together three skills: conceptual described as the ability for the entrepreneur to view the future and trace a vision, technical, related to the ability of the individual to apply all the learned and acquired skills previously learned through education, and human skills which are the general abilities contributing to the individual's ability to communicate, interact and be part of a group.

## **2.2. History of entrepreneurship**

Enterprise education is becoming, and will continue to become, an integral element of any future academic programs in schools, universities and colleges, where it will expand into an established and ultimately accepted field of academic inquiry. Courses in entrepreneurship have merged as the settlement of markets all throughout the world, mainly in industrialized countries that have become aware of the necessity behind teaching this course. There have been debates over this discipline to be thought only in business schools or should be generalized into other disciplines. With the increase need of independent lifestyles and highly professional jobs, the call of teaching this course has emerged. People are more in need to prosper and increase their self-existence, knowledge, awareness, and independency, the call for teaching entrepreneurship has become a challenge. Before coming into the era of teaching entrepreneurship as a discipline, the phenomenon of business venture has emerged as the beginning of trade. The original entrepreneurs were, of course, traders and merchants [8]. The first known instance of humans trading comes from New Guinea around 17,000 BCE, where locals exchanged obsidian, a black volcanic glass used to make hunting arrowheads for other needed goods. These early entrepreneurs exchanged one set of goods for another [9]. Then comes the era on new cities where human civilizations began to spring up near rivers like the Nile, the Tigris and Euphrates. In the first cities, writing was developed to keep track of crops. In this period, the first armies developed and the first city governments were formed. Agricultural settlements had put humanity on a rapidly developing path toward intellectual and scientific advancement. After that came the expansion of the trade route. With the importance of Atlantic trade, power shifts toward the West as Europeans colonized and laid the foundations for a globalized world. The reconnection of the hemispheres marked a major turning point for the species. The next era is the creation of money; early forms of money (called specie) are often commodities like seashells, tobacco leaves, large round rocks, or beads. While the money system still had much development to go through (credit and paper money did not yet exist), its invention over four thousand years ago was of crucial importance to the world we live in today. The use of money, an accepted medium to store value and enable exchange, has greatly enhanced our world, our lives, our potential, and our future. Right before the industrial age, the west has lived the phase of the markets creation. With a population spurt starting around 1470, cities, markets, and the volume of trade grew. Banking, initially started by Ancient Mesopotamians, grew to new heights and complexities; the guild system expanded; and the idea that a business was an impersonal entity, with a separate identity from its owner, started to take hold. Silver imports from the new world drove expanded trade and bookkeepers created standardized principles for keeping track of a firm's accounts based on Luca Pacioli's accounting advances.

Early entrepreneurs, called merchants and explorers, began to raise capital, take risks, and stimulate economic growth. Capitalism had begun. The last period that has marked the lead of the entrepreneurship birth is the start of the industrial age. It truly began in 1712 with the invention of Thomas Newcomen's steam engine in Devon, Britain. But it wasn't until James Watt's steam engine in 1763 that things really got moving, enabling work to be done through the movement of pistons rather than the movement of muscle. While critical governance institutions are required for the effective functioning of capitalism, the market system has been one of the most significant innovations in the history of humankind [10].

### 2.3. Shift to entrepreneurship education

Based on the above milestones of entrepreneurship history and trends, we see the emergence of an SME (Small and Medium Enterprise) economy, which leads to the need to prepare and educate potential entrepreneurs to identify opportunities in the environment, and provide them with the knowledge and skills necessary to capitalize and manage these opportunities. In the education field, this remarkable shift in the human mindset concerning innovation, shift from one situation to another, the evolution of human relationship for the sake to making living comfortable, that has ended with the great system of governance called capitalism has raised issues into putting into emphasis entrepreneurship as a discipline. It was not until the forties that the notion of business building and entrepreneurship came into place. The following table describes the evolution of the teaching of entrepreneurship course.

Year	University	Subject	Professor/ Author
1947	Harvard Business School	Mngt of new enterprises	Myles Mace
1953	New York University	Entrepreneurship and Innovation	Peter Drucker
1954	Stanford	Small Business Management	
1965	University of Oklahoma and Purdue	Entrepreneurship	Arnold Cooper
1967	Stanford & NYU.	Contemporary MBA Entrepreneurship	
1972	University of Southern California	First entrepreneurship concentration	
1976	University of Southern California	First undergraduate concentration	

*Figure 1: Early Classes of Entrepreneurship Education in US Universities*

The statistics of entrepreneurship teaching has shown the following evolution:

By 1975, there were 104 colleges/universities with entrepreneurship courses. In 1979, 127 undergraduate schools offered small business formulation courses. In 1982, 315 undergraduate schools included entrepreneurship courses within their business field. In 1986, 253 colleges/universities had entrepreneurship courses and 590 undergraduate schools offered the course. In 1987, the first undergraduate entrepreneurship course in a Marketing Department was offered at the University of Illinois- Chicago. Since then the spread of the course teaching was in upswing until today where other developing countries have adopted the course teaching within both business fields and other disciplines. Up to today more than 3000 universities worldwide are emphasizing on teaching this discipline among its major studies [11]. The next step is about the nature of teaching entrepreneurship. It is apparent that management approaching the twenty-first century faces formidable challenges both nationally and internationally necessitating the need to accept uncertainty, an ability to cope with change and a quest for creativity.

## 3. TEACHING METHODOLOGIES OF ENTREPRENEURSHIP

### 3.1. Traditional approach of teaching entrepreneurship

Earlier, business schools have opted for a basic methodology of teaching this course. It was also called "small business strategy".

This has given it a more of a theory base form in which the course load relies heavily on talking about the history of businesses, how the human kind has evolved, how it has built a convenient surrounding to make life hassles less difficult. The main course objective is to understand the fundamentals behind starting a business, the reasons behind the rising of the entrepreneurship awareness, and the strategies used to make a business successful, assuming other conditions being stable. The course includes lots of managerial disciplines such as business management strategies, operations management, human resources, marketing, and finance. The student is assumed to understand partially all the stated disciplines. This makes the course have more of a sense of a comprehensive subject because it groups lots of subject areas already studied. The other side is market economics which gives a detailed analysis on the effectiveness of market and industry studies enabling students to have a grasp on how to study industry elements and distinguish between the business and its industry. The notion of “learning by doing” has seen the light due to the increase and emphasis of entrepreneurship course solely on theory. While students are learning all the theoretical concepts of entrepreneurship, time has come for them to embrace real life adventure. They want to dive into the reality, get out of the slow course motion and get into the adventure of starting their own business ventures from a single idea. The following table summarizes the course process. The inputs column relates to the acquired knowledge and foundation by the students prior to taking the course. Entrepreneurship programs should not be assumed generic in nature but rather take into consideration the requirements and needs of students. Examination of the various antecedent criteria allow us to customize content, assessment, teaching methodologies more specific to student requirements. The Content focus describes the variation of topics which are incorporated into an enterprise program, which again will be varied according to student profile. More specific content is to be reviewed within the contemporary fashion of lecturing this course being covered later within this article. Teaching focus is described into three different types:

- Didactic methods include lectures, provision of selected readings, text books, and seminars allowing for the provision of new information which achieves the cognitive objectives of the program. The use of didactic methods helps students to become accustomed to using immediate data, analysis and interpretation of these data.
- Skills building methods are used to generate increased effectiveness in the behavior of students, which result in existing skills enhancement and the development of new skills. Active case studies, group discussions, brainstorming, etc., are used to achieve the objectives of these methods.
- Discovery methods encourage learning through discovery and experiential learning. This involves learning by doing, by involving students in problem solving in real-world situations including the solution and action component. Contact with external organizations provides a greater opportunity for the building up of networks which have potential for career enhancement. Students also work on a consultancy basis in teams with small firms, which is very effective approach in providing hands-on experience with the small firm sector [12].

The outputs can be assessed on a tangible and intangible basis. The tangible effects are the development of products, prototypes, drawings etc. It is critical to ensure behavioral and skills outcomes also exist in the context of personal skills, behavior and career outcomes. The table below does not include the environment which is the elements that affect positively and or negatively the business industry. It is a deep research study enabling potential business owners to assess the opportunities and threats. This requires student to go out to the field and explore the real industry under which the business operates. It is also a tactic that will be greatly detailed later in this work within the contemporary teaching methods. Traditionally speaking, lots of emphasis is put on the course load, books cover content that is already viewed and theories that

talk about the birth of entrepreneurship era and history. Getting students to be deeply involved is what is missing in the standardized form. The course itself is a business venture, in other words, it is an application of all disciplines reviewed in the content focus part of this table. Another element that is not to be forgotten is the students' entrepreneurship spirit which is the most critical factor contributing to the success of the business venture.

Below is a summary table:

<b>Inputs Students</b>	<b>Content focus</b>	<b>Teaching focus</b>	<b>Outputs</b>
Prior knowledge base Motivation Personality Needs/interests Independence Attitudes Parental influence Self-esteem Values Work experience	Entrepreneurship defined Intrapreneurship Innovation New product development Idea generation Market research Feasibility of idea Finance Production Regulations People management Teamwork Business Marketing Management	Didactic (reading/lectures)  Skill building (case studies group discussions) presentations, problem solving, simulations, teamwork, projects)  Discovery (brainstorming, personal goalsetting, career planning, consultancy)	Personal (confidence communication)  Knowledge (enterprise, initiative, self-employment, business, management and market skills, analytical, problem solving, decision making, communication, presentation, risk taking)  Career (improved knowledge, broader career options, broader less structured career perspective)

Figure 2: Input, Content, Teaching Focus, and Output

### 3.2. Contemporary tools

In today's highly competitive environment, the methodology used in teaching entrepreneurship course is definitely subject to change and innovation. As mentioned previously, it is a business venture in itself. The focus is not only on theory and previously learned chapters of management, human resources, accounting, finance, and marketing. Potential students willing to learn about this subject area have to get the grasp of the "action learning theory" known as "learning by doing". The fact that the basics are acquired is a known fact; however, they all should be applied at some points during the teaching of the course. If the disciplines are taken separately, each subject could be practiced with a specific project. When all combined, they call for a single project with a presentation and an academic report called business plan. The following are all examples of teaching methods adopted in the entrepreneurship course.

#### 3.2.1. Cases

Case studies are about real stories illustrated in companies' files. They portray how people and or organizations tackle specific business situations; the critical thinking is a major effort looked up by students in order to succeed in analyzing the case studies. They are a great illustration of real and effective business events. They could relate to the implementation of new strategies, the introduction of new products and or services, and a future step up such as an expansion plan or a globalization. Students, while studying case studies are involved in theory understanding, application, and further research. From one side, cases make them be creative and innovative, from another side, since they are most of the time centered on groups; students get to learn how to be effective team members. Cases also call for two outputs: a report that focuses on writing about the strategy adopted and a presentation that illustrates the research done. As a result, a case analysis evaluation stands on five main points: research, theory fundamentals, strategy implementation, creative thinking skills adopted, writing skills through a report, and

presentation and communication skills. An increased focus on the context and learning by doing implies greater student involvement during the study. Involving the students in working on real business cases could range from case-based teaching, to involving the students in real start-ups [13], and finally by letting the students start their own company. In addition to the degree of individual involvement from the students, the nature of the opportunity or business idea is important in entrepreneurship [14]. The students could work on projects ranging from practical exercises which do not have any business potential, to real business projects with limited potential (e.g. regional scope), and finally high-potential global business ideas. The case analysis process occurs at a certain time in the learning process, it gives a chance for students to start thinking about the bright side of starting or thinking about a business idea. While other tools come as the course progresses, cases should be covered during the high potential phase and the active mindset for student involvement phase. The degree of student involvement and opportunity or business idea potential are illustrated in the following figure:

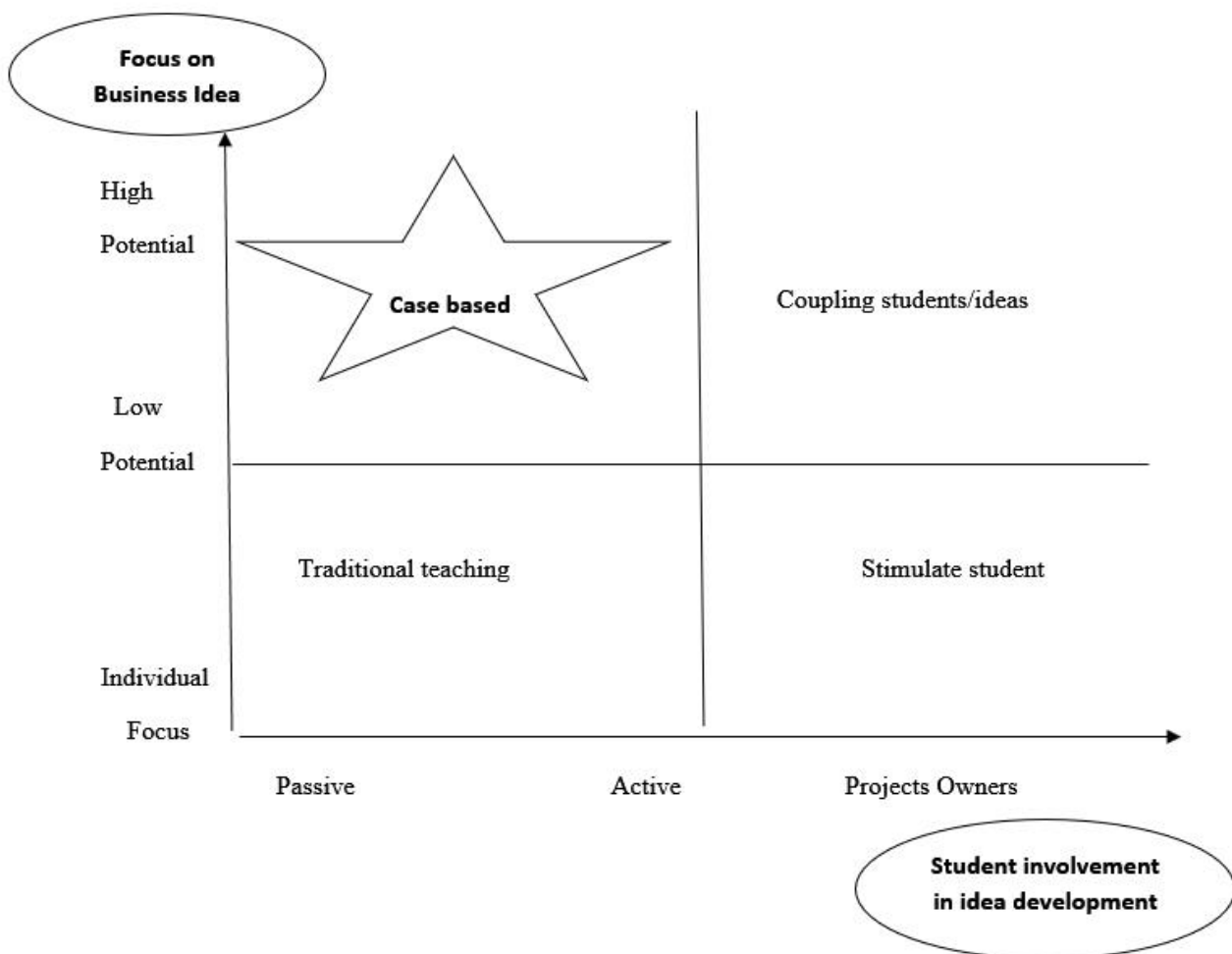

Figure 3: University Strategies for Entrepreneurship Education

Case studies are a good training method that gets students involved in problems and resolutions findings. They get them to understand how businesses operate in real life because they are extracted from reality. Cases are tools that gather managerial issues related to how people and or business venture get started, implement new products and services, market them and even set prices. They deal with critical problems and ensure that students use their imagination enough to come up with crucial solutions. They mirror the existing situations of businesses.



### *3.2.2. Conferences*

Conferences where learners spend time together learning collaboratively can build learning communities of a sort. To meet the spirit of the standards, participants in academic communities commit to not only to learning together but also to integrating the learning into an ongoing cycle of continuous improvement. Because conference leaders are essential for effective professional learning that impacts all teachers and students in systems and schools, standards-based learning must include opportunities for leaders to engage in deep learning. Leaders benefit from attending conferences with others in their system. Education leaders have a responsibility to document the impact of that investment for those who support it. Any initiative at work in school systems today has a data aspect associated with it. Implementing student standards, for example, requires constant assessment of progress. Therefore, any effective learning experience encourages individuals to use data to guide decisions about learning and determine how new learning is assessed. Different designs are used to promote different outcomes. Gaining clarity about the outcomes an individual intends to achieve with a learning opportunity is key to success. Exceptional learning opportunities recognize that individuals arrive with different backgrounds, expectations, and goals. Therefore, conferences offer a wide range of learning options that lead to different outcomes. Attending conferences with colleagues can lead to more sustained learning in teams or through school-based coaching. Others may find support in joining communities launched during the conference experience. The first question to ask in weighing a potential conference is, "How will this learning experience help better ensure improved system growth, educator practice, and student outcomes?" Any professional learning-conferences included--must help educators boost their knowledge and skills to better reach students.

### *3.2.3. Success stories*

Success stories are brought to the classroom to recall on the bright ideas that were born from scratch and been developed into successful business ventures. Business owners, for most cases, are students or young entrepreneurs. They are great example of real business cases who come to share their startup stories with the willingness to help, give insights on how things operate in the outside world. By this, students encounter people from the industry and get to learn from their experiences. They are knowledgeable about rules, policies, failures, and remediation strategies. They are in the spirit of "been there, done that". I believe that success stories are a resource because they have so much potential for the students. The art of sharing is such a powerful learning tool simply because personal lives are everyone's interest and it touches the students' hearts more than their brains. If merged with other methods, success stories tend to have positive effects on the minds of entrepreneurs. It is considered like a boost to the students' ideas and could drive them in believe even more in what they are hoping to achieve in their future business ventures.

### *3.2.4. Market studies*

One other way to get students out in the real world is via market studies. This does not limit itself in the customer interviews only but also on the industry research. Students have lots of questions concerning their industries, policies, regulations, statistics, key success factors, opportunities, and threats. There exist centers that help students promote different kinds of businesses, however, for most cases, students have to build their own industry networks, look for stakeholders and partner themselves with potential industry leaders. Market studies are great source of information when it comes to the legal and political system. Entrepreneurs have a tendency to ignore this area as the laws are complex and their usefulness is limited to different types of businesses.

Solid partnership with legal, political, social, and economic sectors is fundamental to the success of teaching and building the potential business venture. As all this fall into the “learning by doing” theory, market studies are effective.

#### **4. BUILDING ENTREPRENEURSHIP MINDSET**

One of the most crucial steps in the entrepreneurship thinking is to build the mindset. Some people think they are or have the spirit of entrepreneurship innate, once they do live the real moments of having to face obstacles, they notice that they have the perseverance to face or even cope with the threats and or the weaknesses jeopardizing their business. Within this part, I will go into explaining the process of building the entrepreneurial mindset then I will proceed by giving some tools before writing about business plans.

##### **4.1. Process**

The building of the entrepreneurship process starts by thinking about a personal story that relates to the environment needs. A true entrepreneur thinker has got to first think far beyond over what is missing simply because while he is doing so others are thinking about the same idea. Merging a personal story to the external environment makes up the start of the mindset process building. The foundation of the entrepreneurial mindset is the cognitive adaptability, which is defined simply as the ability to be dynamic, flexible, and self-regulating in one's cognitions given dynamic and uncertain task environments. Adaptable cognitions are important in achieving desirable outcomes from entrepreneurial actions [15]. A metacognitive model of the entrepreneurial mindset integrates the conjoint effects of entrepreneurial motivation and context, toward the development of metacognitive strategies applied to information processing within an entrepreneurial environment. Social cognition literatures describe the entrepreneur as a ‘motivated tactician’, representative of “a fully engaged thinker who has multiple cognitive strategies available, and chooses among them based on goals, motives, and needs [16] to act (or not) in response to perceived opportunities [17]. This perspective is known as metacognition which is the deep thinking” [18] to develop a model that concomitantly describes the process through which the goals and motivations of the entrepreneur, as well as the attributes of the entrepreneurial context, are represented and ultimately serve to define metacognitive strategies which are responsible for framing how one senses, reflects, and adapts strategies to ‘think’ about entrepreneurial action. The model of the entrepreneurial mindset makes three primary contributions.

- **Personal story:** an entrepreneur has to sense his needs and relate them to the environment, he sure is a dreamer but somehow a realistic dreamer that could envision all the pitfalls before they occur and relate to what he has got within his reach, a good entrepreneur should have beforehand some qualities quite different from other individuals. Self-confidence comes upfront; self-awareness is as important and then comes the passion, a quality that drives the entrepreneur’s ability to bypass his rivals in a world full of uncertainties.
- **Metacognition:** is a deep understanding of self-worth and capacities. As mentioned previously, it is the driving force of the entrepreneur actions. By mastering one’s capacities, likes, dislikes, and abilities, an entrepreneur can choose from a set of available options, given what the individual understands his own motivations, assumptions, strengths, and weaknesses [19]. To acquire that state of mind, think one should think out loud, reflect, be strategic, and plan. Importantly, metacognition is a dynamic, learned response that can be enhanced through education, experience, and training [20]. In essence, metacognition represents the control that the individual has over his own cognitions as a function of a differing ability (between individuals or within an individual over time or from training) to consider alternative cognitive strategies in light of a changing environment. Given this conceptualization, it follows that control over one's cognitions that results in an ability to

consider alternative cognitive strategies makes for more dynamic information processing; the normative implications of metacognition are potentially important in entrepreneurship. Alternatively, studies have demonstrated that individuals constrained in their metacognitive abilities are less likely to engage alternative strategies, and are therefore less adaptable when the decision-context changes, or when it is novel and uncertain [21].

- Training on the process: this is acquired through education using contemporary methods like cases, success stories, and market analysis. People have a tendency to learn from others and each other. Entrepreneurship education is a deliberate attempt tailored towards the building of knowledge and skills about entrepreneurship. This is part of the recognized education programs at primary, post basic and tertiary levels. Educational institutions at all levels adopt approaches aimed at encouraging creativity, innovation, critical thinking, opportunity recognition, and social/self-awareness. Entrepreneurship thrives in an economic system where diverse stakeholders play key roles. Central to providing entrepreneurship education are academic institutions. Through entrepreneurship education young people, including entrepreneurship facilitators that have been trained, even those with disabilities learn organizational skills, time management, leadership development and interpersonal skills needed to organize a venture, the conglomeration of which are needed to give effect to economic growth and development.

#### **4.2. Idea conception**

Once the mindset is developed and is ready to operate and give output, the idea conception has to be installed. To create an idea, the entrepreneur has first to think about a value proposition. The value proposition has the bypass the idea itself in a way that one should think about how to impress. The heart of the idea is the value proposition because entrepreneurs do not think about what they have to sell but rather the value of what they are selling. Sustainability of the idea is to be considered. The idea should bypass the good and or the service to be offered, the potential business owner has to make sure that he or she is selling an experience simply because he is thinking at something that everyone else is thinking about. What distinguishes his idea from the rest is the value that he is suggesting within this experience, again, not his good. The value proposition is to be seen not by himself only but by others whom he encounter on everyday basis. The source of the idea comes from three different and yet interdependent sources. The first one is a personal story that suggests that the business venture idea comes from a desired passion that the potential entrepreneur carries. No individual will think of building an IT firm without mastering IT tools and knowledge. The same goes for a kindergarten being owned by someone who does not love children. A personal story carries on the dream that the entrepreneur would like to put into reality. It holds so many important tools that drive individuals into a huge imagination to the point that they start even forecasting for positive and or negative effects of the business venture. The second source of the idea comes from the mindset, within this framework curiosity holds the biggest portion, the “ifs, how’s, and whys” start to build up within the minds, the answers at that stage would require market studies, experts, counseling, and other stakeholders with the ability to direct, orient, and give information. This falls into the type of mindset framework that the idea holder carries. The third source is the set of activities; they call for the different actions to be done in order to make the idea more stable in the heads and ready to be framed. Entrepreneurs to be cannot wake up one day and say they will make profit simply because outcomes are outside their control and the only thing they can promise are efforts rather than results. In this case, the set of activities are the efforts and means to drive the output. They are also dependent on the mindset and the human story which make the three components interdependent, all together. They are also intertwined. The three buckets that fall under the set of activities are the thinking, the cognitive box of the activity, the sensing such as speaking, listening, feeling, intuiting, and the moving which

includes typing an email, setting up a meeting, asking questions. The significance of knowing the above buckets help idea holders organize their time, efforts, and evaluate themselves as future entrepreneurs. The following figure summarizes the idea conception model:

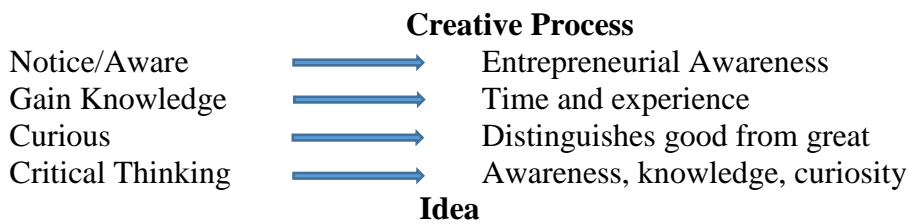

*Figure 4: Creative Process Thinking of Entrepreneurship*

### 4.3. Tools

The next step is to draw the thought into a platform. There exist so many tools to help entrepreneurs put down their ideas into readable and clear sheets enabling them and potential lenders and investors to view their ideas. Some of them are very formal and academic, however, are very detailed and considered the source of the bulky work. They are a backup source of information and could be looked at any time during the startup, building, growth, or decline phase. Some tools are used for a single time and others more often. They serve as little documents carrying thoughts and actions mentioned earlier. By this time, idea is set; megatrends are reviewed as part of the market study. It is time for value proposition to be tested. The individuals and or parties interested in value proposition are potential customers. What is needed to do is to go out and do brief customer interviews. They could take the form of observation, brief question and answers, internet small surveys, and for some cases, a prototype. They rise up information coming for the consumers, showing their likes, dislikes, acceptance of the value proposition, or the complete opposite. Besides customer interviews, there is exist a special form called CUSB canvas, “Customer Unsatisfied need, Solutions, and Benefits” allowing idea holders to brief up their thoughts into an organized sheet covering the above said element, thoughts, activities, value proposition, results of surveys, and could go all the way to element related to funds and sources of income. CUSB models have made it simpler for idea holders to put own the major points about their business venture into life. They are useful also for students taking a workshop of few days going to weeks just like for an academic semester where students have to go beyond CUSB canvas and develop an entire plan. In this case, the canvas is just a startup of the work process [22].

### 4.4. Business plans

For academic purposes, business plans are considered the most classical output of an entrepreneurship course. Through business plans, students get to write down all their courses of actions mentioned above, the personal story, the set of activities, the mindset, the CUSB detailed into all parts, the megatrends, industry analysis and so on. Business plans are varied and could come in different versions depending on their readers, time requested for them, and the functionality of their content. However, their power resist in their purpose, which is in most cases, to get funds. The other one reside on them being a roadmap on how to dig in a new venture in a world full of uncertainties. Business plans are the most common form of ensuring that students have gone into a deep analysis of their business venture. During the course lecture, students have encountered during the learning process.

#### 4.4.1. *Elements of a business plan*

Business plans have been used universally in all entrepreneurship courses offered worldwide. Each professor has the right to modify few of its elements but they have a consistent format. The elements of a common business plans are the following:

- **Executive summary:** the first part that appears in the plan but the last one to be written. It is a consistent part of the whole work through which even a decision to invest in a particular venture could be made. An executive summary is written last for the simple reason that it summarizes all major parts of the business to be discussed in the business plan. It gathers and briefly five main elements which are the personal story, followed by the megatrends, the strategy the business venture is willing to pursue, the target market analysis with the tools appropriate, the sources of funds, and the projected income scenarios.
- **The business mission, vision, values, principles, and value proposition:** These are the points that help outsiders have an idea of what the business is about without reading the details that follow. A concise mission has to answer three questions: the first one is about the purpose of the business, the second one is about the way the company will achieve that purpose, and the third one is the value driving the success of the venture. A vision is the intended mission of the future of the business venture. It is more of a dream, it is so important that it enables to extend the imagination mind of the idea holder. The value proposition holds the uniqueness that the business holds enabling it to transform the good and or the service into an experience.
- **The industry analysis:** is all about the megatrends, the economic background of the business, made up from other players which are existing businesses within the industry, statistics, growth phase, legal restrictions, other stakeholders potentially connected to the business and future of the industry. Within this part, students are called to do extensive research, focused around the market study previously mentioned.
- **The business analysis:** in this part, students are called to apply managerial tools studied in previous courses. The business analysis includes a SWOT analysis, its defensive strategy highlighting ways to overcome its weaknesses and others to cope with threats, company's goals and objectives, the competitive strategy, and the products and or services features. The competitive strategy could be a differentiation, basing its success on uniqueness only, a cost leadership competing on cost, or a focus via concentrating the efforts on a single target market. This part includes also a comprehensive analysis of products and service features.
- **The marketing analysis:** here come all the curiosity effects of the mindset built up in the idea process development. Within the marketing part, there is a big focus on the target market done via the customer interviews, enabling the potential entrepreneur to understand their needs, wants, desires, spending habits, consumption measures, likes, dislikes, quality attributes, and other factors like psychographics, demographics, and social factors. Marketing analysis does not focus solely focus on customers but touches also competitors with their strengths, weaknesses, along with the bypassing strategy. Before location, layout and distribution strategy, there is the advertising part. The most crucial tactics are to be developed within advertising campaign ensuring that the product, the service, and the experience reach the target market.
- **The financial analysis;** focuses of three main point. The first is about the sources of funds which are multiple. Some are internal, within the reach of the idea holder and others require deep research, making them external and out of reach. There exist within this measure angel investors, friends, families, organizations whose needs are within the business with the willingness to help and empower the business at least at its startup phase. Potential entrepreneurs should reach financial agencies; however, these last ones are the last to involve in a startup. The second major component of the financial is the projected income

statement, where the price is set up depending on the market price floor and ceiling, allowing for a profit margin to be in place. There are three simulations: the first one is an optimistic scenario, projected an image of overestimating the revenues while holding external conditions stable, the second is the realistic scenario, assuming that things will go as projected for. The last one is a pessimistic scenario, underestimating all factors and overestimating the risks of failure. Students, at this age, have a grasp of the financial measures to be considered and with the three scenarios take in consideration lots of factors that could jeopardize the success of their business venture. The estimation is not supposed to not exceed one year of operations because once the business starts, there is a clearer forecast of the near future. The third element is about the cash flow statement making sure the entrepreneur is able to rotate the incoming and the outgoing liquidity of his investment.

- The human resource: this part is as important as the others simply because it deals with the employees, being considered in most cases, as source of inspiration. They are to inspire and being inspired from. A good selection, training, and compensation are the key to holding them liable and committed to the business. Students are to understand that employee involvement gives them a feeling of belonging and ends up being the number motivational factor driving their satisfaction and in return their productivity.

From the above elements, business plans are and will stay the solid output behind succeeding entrepreneurship, as course.

#### *4.4.2. Pitch and presentations*

The pitching of the business venture is a very important part of the whole process. Pitching help business owners speak up about their potential venture, otherwise, their work will hold up another spot in their desks. There are three tests entrepreneurs have to keep in mind. The audience and or the interested parties are looking for weaknesses, threats, and risks management techniques. They are analyzing the business venture based on three main points. The first one is the feasibility test, proving that there is an existing market for the product, service, and experience that is to be sold. The second one is competition test checking for the different signals for an existing competition for the offering along with a bypassing strategy over the rivals. The last one is the value test. It is the financial simulation that should ensure that the business is financially profitable, guaranteeing to the audience that their investment is worth more in the future and will have a great return. Once students accomplish the plan, there is a call for lenders, investors, potential parties affecting directly and or indirectly a business. These parties have to be part of the work; they need to be involved, to share their opinions, experiences, backgrounds. They are scholars, business owners, financial experts, lender, marketers, quality experts, and advertising agents. The list is long and can reach even external parties, having or willing to build a connection with the involved students. For some universities or educational institutes, this is the beginning of startup actions going around the country and even abroad. The pitching of the business ideas is the moment of truth. Business plan presentations can take different forms. The academic presentation is the longest, most concise, and detailed. It lasts for 20 minutes, presented in front of a panel of jury, namely individuals from the business field. The most crucial timing of this presentation is the first two minutes. They enable the audience to have a clear idea about the business venture to be and make the follow up smooth and clear to analyze. This presentation is followed by a question and answer session where the practitioners from the panel get to dig in the thoughts and get students involved into the weaknesses and threats, which, are not mentioned in the presentation but are cases prepared for by the presenters. Innovation and creativity are also important factors in succeeding the presentation because it has to fulfill the other mission which is the sales persuasion. Besides attracting lenders and investors, presentations are the biggest sales pitches that potential entrepreneurs have to consider. The other type of presentation that is not

necessarily academic is the “elevator pitch”. It is the least one in terms of timing. However, if well done, it has great impact of persuasion simply because its success rate tends to be either high or inexistent. The listener has no time to argue, his analysis is very limited to the amount of time spent with the potential entrepreneur. The idea is either highly sold or doomed to failure. The elevator pitch is the best way to present a CUSB model because it is the quickest to model as a speech and include the basic elements that the listener looks for in a short amount of time. The third type is tailored toward a specific target audience. In this case, the judgment over the pervasiveness, the uniqueness, and the feasibility is judged by the interested party. In most cases, potential business owners prepare the presentation ahead of time and include only information requested and believed to be useful to the audience. It is one of the most formal ones. It is prepared to get some legal documents set and in some cases to acquire a source of funds. There exist also some special forms that are provided to the entrepreneur in order to fill out and submit along with the presentation. All in all, presenting business plans or any business idea pitch, as it takes various forms, is part of the creative work that is to be delivered by the business owner. While creativity has to take place all throughout the process, as stated above, it is a major component to be carried by the entrepreneur to be. Communication with all its elements is as important in the entrepreneurial work as other disciplines. It is the completing component of the mindset, the business plan. They are all interdependent and complementary. As we notice that ideas not well presented end up by failing, not considered, or picked by others.

## **5. CONCLUSION**

This article highlights the growing need to create an enterprise culture which will encourage and foster greater initiative and entrepreneurial activity. Although there have been efforts provided over entrepreneurship education, currently the focus and process of education is too mechanistic and does not promote or encourage entrepreneurial behavior. Therefore a considerable challenge faces educators and trainers to derive programs which are appropriate for preparation for learning in the world outside. It is important to distinguish between education in terms of theory and in the external environment. In order to ensure the correct objectives, focus content and teaching methodologies are used. The process for entrepreneurial mindset and education facilitates this. The current methods of entrepreneurship education provide for multiple alternative structures and learning mechanisms to ensure learning is targeted to accommodate students’ requirements. It provides for an integrated approach to enterprise education. Enterprise education should be incorporated into business disciplines, where students should be taught the knowledge and skills required. The provided methodologies provide an important set of guidelines which can be used by educators when designing programs to suit different student groups. It is critical that entrepreneurship education is adopted in an integrated manner where interdisciplinary teams and project work are encouraged. This allows educational institutions to benefit from the expertise and synergies that can be obtained from cross-functional learning. This integrated learning by students will create an improved awareness of the reality of working in progressive organizations, but perhaps more importantly it will provide students with the awareness, interest, and preparation for self-employment as a career alternative. For education institutions to adopt this integrated approach it is critical that faculty endorse it and are prepared to allocate resources and time to ensure this enterprise culture is evident in their institution. The fruit of entrepreneurship education is and will prosper as the globe is progressing.

## **6. SURVEY ANALYSIS**

A survey was provided to master students taking the entrepreneurship course for one semester. The group gathers 100 students; all of them are preparing Master degrees in Management with different areas of concentration: Management Information, Finance, and Marketing. They are in their last year.

Their ages are ranging between 21-25 years old. The survey objective is to analyze their feelings, perceptions, impressions, and expectations from Entrepreneurship course. It tackles different points that are to be taken in consideration when it comes to teaching the course.

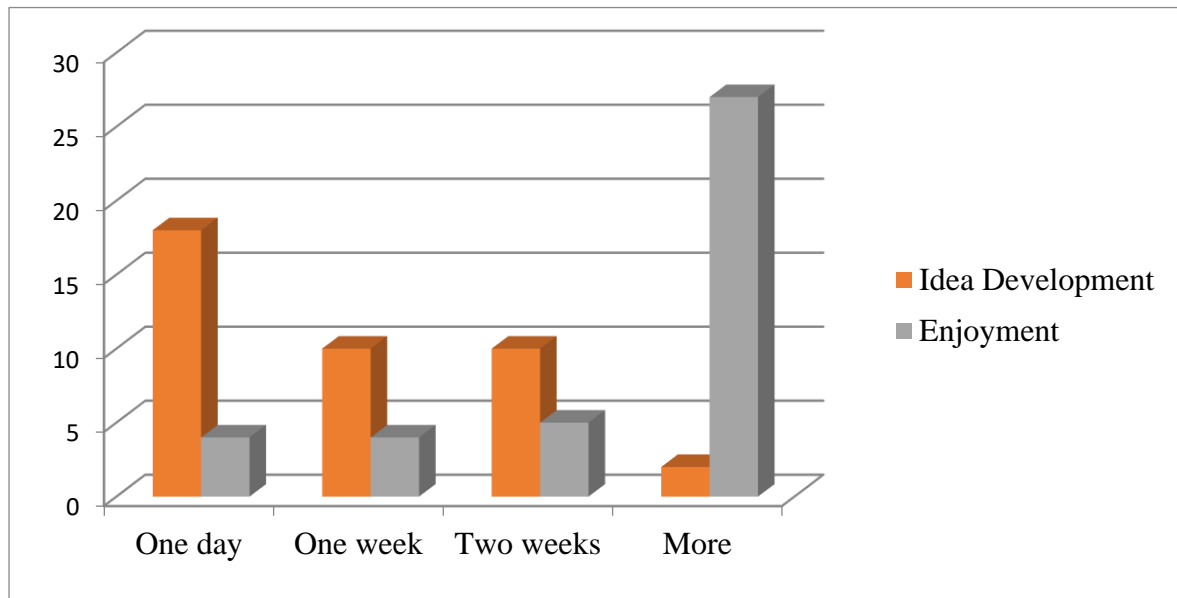

*Analysis 1: Idea dev vs. Enjoyment*

Individuals who take more time to develop their ideas enjoy the course more. This implies that students should be given more time. One semester is not enough; the course should be taken in two consecutive semesters. Also, the mindset building process, if well established and set, will influence positively the smoothness of the course teaching. As a result, students will enjoy the course more.

*Analysis 2: Readiness vs Obstacles*

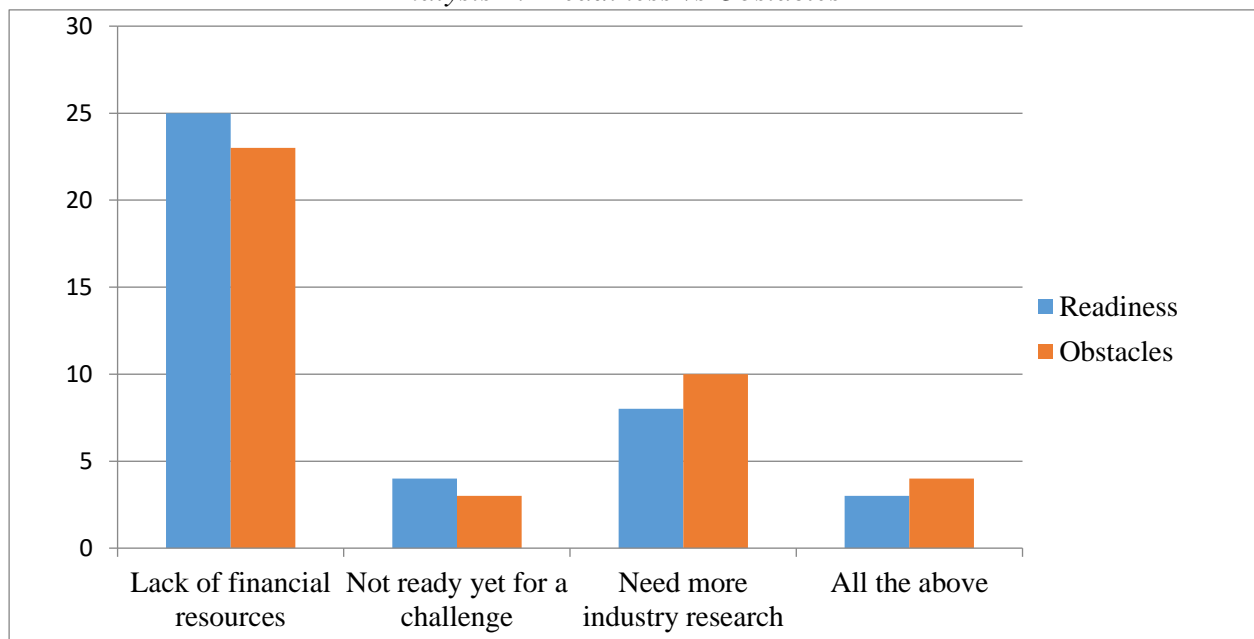

From the above chart, we can conclude that the highest percentages of students who are ready to make in effect their business ideas are also facing the obstacle of lack of financial resources.



This explains that the greatest need is to open up more funding resources and make them available to young individuals.

*Analysis 3: Factors contributing to the course success*

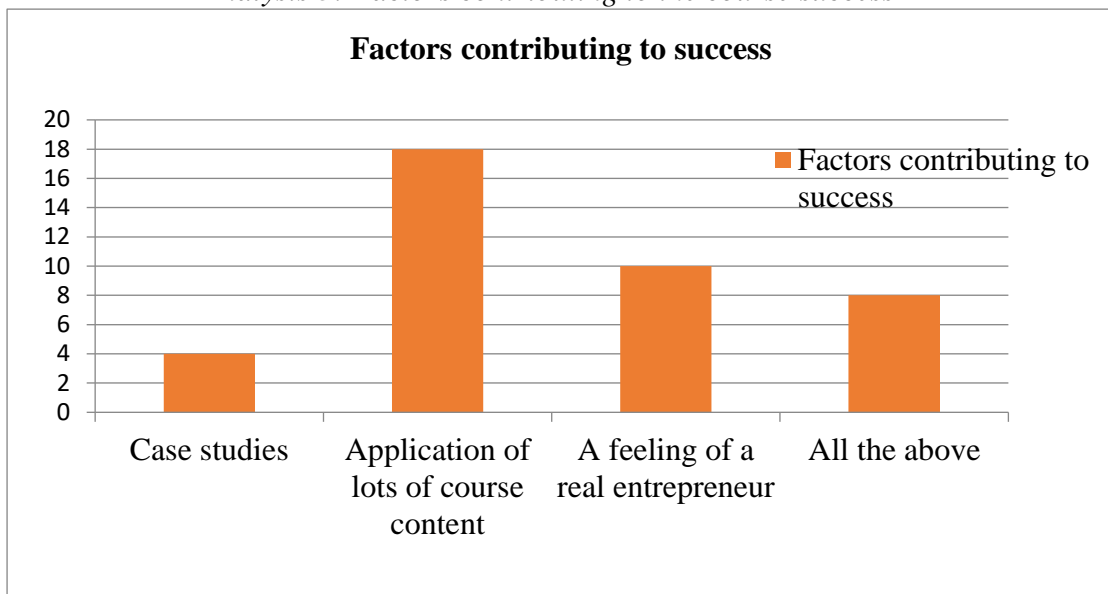

We can conclude that the major two factors contributing to the course success are the application of previous course content followed by the feeling of a real entrepreneur. While students are able to apply some of the courses content, they improve their self-esteem and thus the feeling of being real entrepreneurs start to build in within their profile. A big portion of the course content reside on setting up and improving the self-worth of students enabling them to take initiatives and face the challenge of embracing the nature and launch their business venture, or at least consider it.

*Analysis 4: Factors to prosper vs. Expectations*

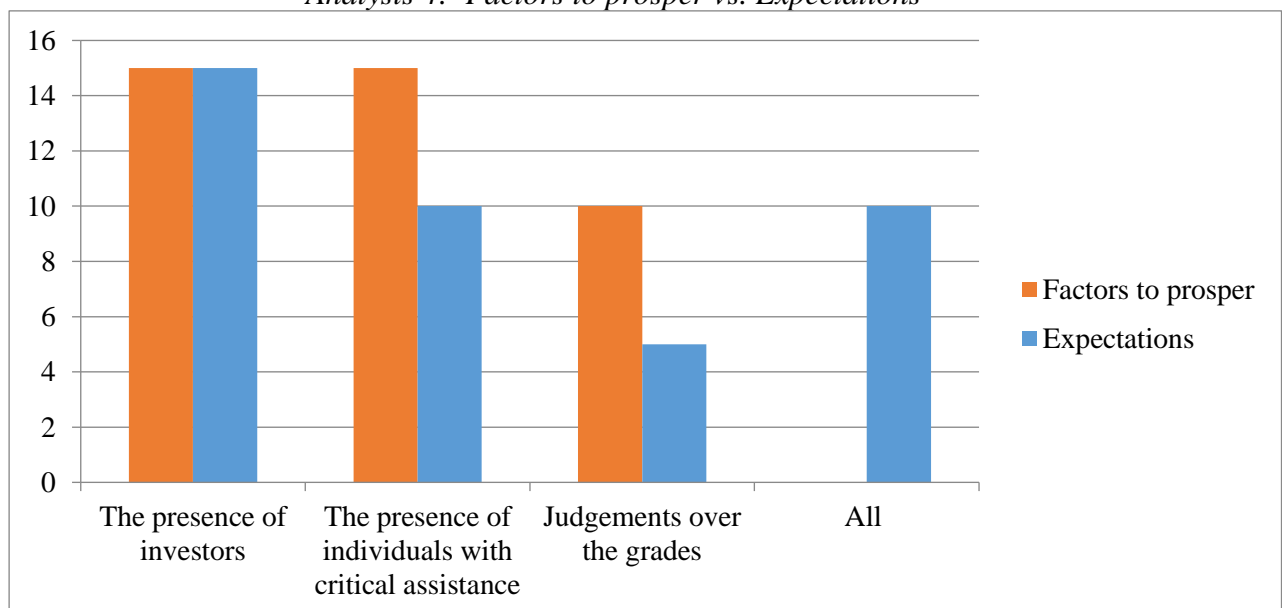

From the above, we can conclude that students who consider the sources of fund as factors to prosper are exactly the ones who recommend the presence of investors while presenting their

business plans. This factor is so important to consider because the lack of funds is inhibiting students from taking the challenge of getting into the real spirit of entrepreneurship.

Analysis 5: Enjoyment of the course vs Recommendations

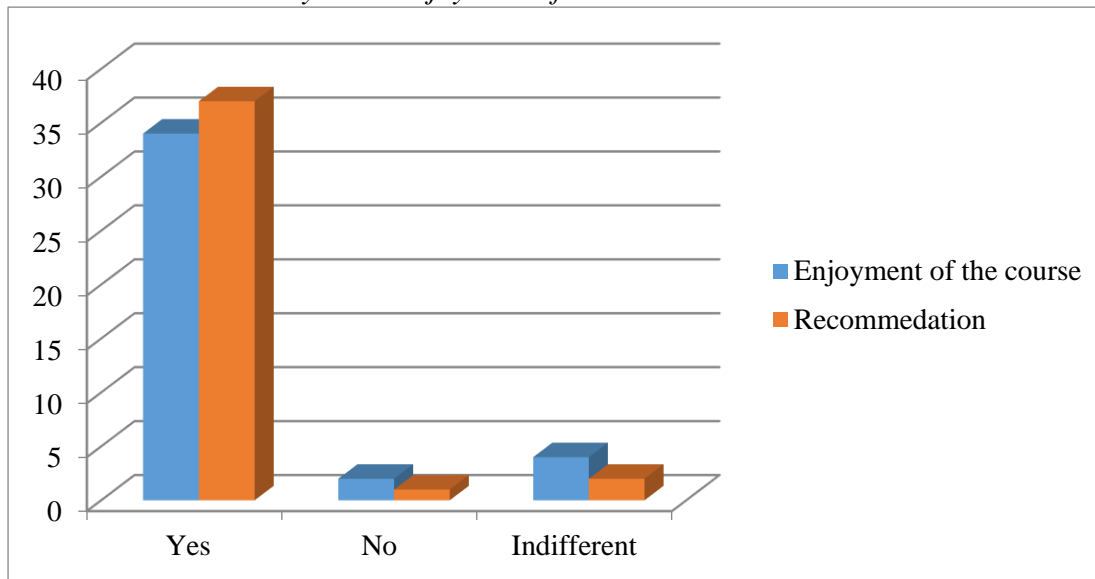

The above chart justifies that the number of students who have enjoyed the entrepreneurship course are highly recommending it to others. The survey has come to prove that students are in need to learn about entrepreneurship as a course in which they are able to use and apply previous courses related content. They are seeking external research, a way to enable them not only to step out of the theory covered in class but also a form of seeking investors and lenders or other parties who may display some interest in their business ventures.

#### LITERATURE:

1. Ronstadt, R., "The educated entrepreneurs: a new era of entrepreneurial education is beginning", *American Journal of Small Business*, Vol. 10 No. 1, 1985.
2. Acs, Zoltan J., and Audretsch, David B. (eds.) (2003). *Handbook of Entrepreneurship Research*. Boston: Kluwer.
3. Alvarez, S. A., & Barney, J. B. (2007). Discovery and creation: Alternative theories of entrepreneurial action. *Strategic entrepreneurship journal*, 1(1-2), 11-26.
4. Baumol, W.J. 1993. Formal entrepreneurship theory in economics: Existence and bounds. *Journal of Business Venturing* 8:197–210
5. Bull, I., and Willard, G.E. 1993b. Toward a theory of entrepreneurship. *Journal of Business Venturing* 8(3):183–195.
6. Curran, J. and Stanworth, J., "Education and training for enterprise – some problems of classification, education and policy research", *International Small Business Journal*, Vol. 7
7. Gartner, W.B. 1985. A conceptual framework for describing the phenomenon of new venture creation. *Academy of Management Review* 10(4):696–706.
8. Gartner, W.B. 1985. A conceptual framework for describing the phenomenon of new venture creation. *Academy of Management Review* 10(4):696–706.
9. Gartner, W.B. 1990. What are we talking about when we talk about Entrepreneurship? *Journal of Business Venturing* 5(1):15–28.
10. Hill, G.E. and Welsh, H.P., "Entrepreneurship behavioral intentions and student independence characteristics and experiences", in Ronstadt, R., Hornaday, J.A., Peterson, R. and Vesper, K.H. (Eds), *Frontiers of Entrepreneurial Research*, Center for Entrepreneurial Studies, Babon College, MA, 1986.

11. Hills, G.E., "Variations in university entrepreneurship education: an empirical study of an evolving field", *Journal of Business Venturing*, Vol. 3 No. 1, 1988.
12. J. Chamard, Public education: its effect on entrepreneurial characteristics, *Journal of Small Business and Entrepreneurship*, 6, 1989, pp. 23–30.
13. Jay Markiewicz, Jay, an Entrepreneurship professor at VCU and coach of Henry Ford Entrepreneurship Academy
14. Marchesnay, M., and Julien, P.A. 1989. Small business as space of transaction. *Journal of Entrepreneurship and Regional development* 2(3):267–277.
15. McMullan, W.E. and Long, W.A., "Entrepreneurship education in the nineties", *Journal of Business Venturing*, Vol. 2 No. 3, 1987.
16. Scott, M.G. and Anderson, A.R. (1994), "Entrepreneurology: the study of the creation and extraction of value from an environment", paper presented at the 14th Babson Entrepreneurial Conference, Wellesley, MA.
17. Sexton, D. 1988. The field of entrepreneurship: Is it growing or just getting bigger? *Journal of Small Business Management* 26(1):4–8.
18. Solomon, G.T. and Fernald, W. (1991), "Trends in small business management and entrepreneurship education in the United States", *Entrepreneurship Theory and Practice*, spring, pp. 25-39
19. Van de Ven, A.H. 1993. The development of an infrastructure for entrepreneurship. *Journal of Business Venturing* 8(3):211–239.
20. Weihe, H.J. and Reiche, F. (1993), "Entrepreneurship interest among business students: results of an international survey", in Klandt, H. (Ed), *Entrepreneurship and Business Development*.
21. Young, J.E. (1997), "Entrepreneurship education and learning for university students and practicing entrepreneurs", in Sexton, D.L. and Smith, R.W. (Eds), *Entrepreneurship 2000*, Upstart Publishing, Chicago, IL, pp. 215-38.
22. Zeithaml, C.P. and Rice Jr, G.H. (1987), "Entrepreneurship/small business education in American universities", *Journal of Small Business Management*, Vol. 25 No. 1, pp. 44-50.

# **CORRELATION ANALYSIS OF SEARCHING TREND OF THE TERM VIRTUAL REALITY IN SELECTED SEGMENTS IN CONDITIONS OF THE SLOVAK MARKET**

**Radovan Bacik**

*University of Prešov, Faculty of Management, Slovakia  
radovan.bacik@unipo.sk*

**Ludovit Nastisin**

*University of Prešov, Faculty of Management, Slovakia  
ludovit.nastisin@gmail.com*

**Richard Fedorko**

*University of Prešov, Faculty of Management, Slovakia  
richard.fedorko@gmail.com*

## **ABSTRACT**

*In this article, we tried to analyse search trends for virtual reality keywords. When looking at the search trend, we have first drawn attention to the most searched terms for 2016 and 2017. The most searched expression was subjected to a correlation analysis of Spearman's specific test within the various available search engine categories. In the last part we pointed out what influences the search trend related to virtual reality in Slovakia and we also described suggestions to support the overall perception of this new platform on the Slovak market.*

**Keywords:** *Virtual reality, Search trend, Correlation analysis, Slovak market*

## **1. INTRODUCTION**

In today's world virtual reality is becoming a step-by-step mainstream and that in a number of industry sectors. The development of virtual reality focuses on gaming, entertainment, marketing, education, fashion, art and many other areas. The trend of improving these technologies is visible on a daily basis. It should be noted that even in 2014, the number of users of virtual reality tools was less than one million. This year, however, there are already over 150 million users with expected continued growth. According to the Zion Market study (2017), the virtual reality market in 2016 was estimated at over 2 billion dollars. On the spot there is also their prediction that by 2022 it should be up to 26.8 billion dollars. The return on investment in virtual reality has a really high rate and in the future there will be companies that make the most of these technologies with a significant competitive advantage. Companies should therefore, to the fullest possible extent, be aware of the importance and potential of virtual and expanded reality and count on investment in this direction. Technology in this area will be getting better and faster. The growing share of virtual and expanded reality in the market is being promoted as both private consumers and companies. Smart glasses or virtual headsets are now used in healthcare, education, manufacturing, logistics and real estate sales. As more technologies come into the market, they are becoming more and more available to the consumer as well. When Oculus Rift was on the market for 799 dollars in 2016, the Oculus Go was for only 199 dollars. Virtual reality is the future and being unprepared for this wave will be a huge disadvantage for anybody.

## **2. VIRTUAL REALITY AND THE EXTENT OF SEARCHING IN THE WORLD OF THEORY**

Today we recognize the importance of virtual reality because the form of virtual reality brings a new dimension. Virtual reality allows us to overcome the limitations of standard interfaces

between man and computer. Virtual reality technologies open our doors to new types of applications that use real world simulation capabilities. The environment in which virtual reality is transmitted can now be defined (Rovaglio, Scheele, 2010) as:

- Fully-immersive: in which to create the feeling that we are in a virtual reality, we use individual components such as glasses and gloves.
- Semi-immersive: in such an environment, the object is looking at the computer screen, and the interaction is caused by the use of the computer's input peripherals such as a mouse or a joystick.

Virtual Reality technology makes it easy to create simulations in real life and creates experience for every user and they really interact with their digital environment. Enhanced reality, on the other hand, creates digital enhancements to enrich the existing environment (Augment, 2016). While many companies are expanding their business with these two technologies, the AR and VR capabilities help businesses in different but important ways. Here are some of the different ways companies use different technologies to fuel growth and development. The upcoming trick for traders will be the strength that the VR holds because a strong sense of physical presence in the virtual world creates a reality that does not interfere with external influences and also makes it possible to gain more information about customers. (Alfalah, 2018). When we think about marketing, everyone will think about ads for detergents or ads that interrupt TV shows. Marketing is now more than an old lady who yells that what we offer is the best product on the market. Marketing is a means through which thought is spread, it is the most important product of our civilization (Godin, 2006). But marketing is not just advertising. Through marketing, we identify the needs and requirements that customers want and we offer them a product that is valuable to them and the company will make a profit (Vilčeková, Štarchoň, 2017). The interesting side-effects of our rapid technological development helped us to realize that reality is fluid. With a communication tool that is as powerful and disturbing as the internet, we received a telescope and a microscope so that we can see how varied is each person's idea of reality (Fraga, 2017). Content marketing is evolving very quickly. Successful brands are starting to be interested in new technologies to positively influence the strategy of their content marketing. There is no doubt that the year 2016 was the year of the VR and AR. Managers are given the opportunity to produce content that is intended for the VR and the idea is not the boundary because the VR is to some extent still an unexplored field. Virtual Reality is an incredible technology with infinite possibilities for market research, from store layout research, through advertising campaigns to product development. Search Volume is defined by the number of searches for the expected keyword for a certain period (Bramley et al, 2018). Search Volume is also used as a keyword analysis metric to help us reach potential search traffic for a specific keyword. However, this volume can never be recorded without any deviation, so we are talking about the estimate or projection of the search volume. We should bear in mind that when working with these data, there may be considerable fluctuations in time. The most common reason is the seasonality of the topic we are looking for if it is relevant only to a specific region (Ryte, 2016; Štefko, Gavurová, Korony, 2016). Keywords allow the user to get a rough idea of the attractiveness of specific search terms and also suggests related, often extended, terms that could improve the search results. From a search engine optimization perspective, search volume is an important criterion that the website should be optimized for. The difficulty lies in whether it is better to use words with a high or a lower search volume for the given case. (Kim, Kang, Taylor, 2018). With a high volume of searches, high competition is often present, as well as high potential traffic from which the business can benefit. However, with a lower search volume, competition from other websites is much lower and so it is easier to get the majority of traffic, which is generally lower than for highly competitive terms.

It is therefore important to analyse carefully which strategy is best suited for the purpose. In practice, however, the most common combination is of both variations. The website should be optimized for strong keywords, but it should also integrate keywords with less competition that are part of the long-tail strategy (Ryte, 2016; Mura et al, 2017).

### **3. METHODOLOGY, RESEARCH FILE AND MAIN FINDINGS**

In this research, we focused on the analysis of the search trend in relation to the virtual reality in the conditions of the Slovak market. Since the data obtained from google trends did not fit the normal distribution, we used non-parametric variants in our correlation analysis (Spearman's test). Looking at the search trend, we first looked at the most searched expressions for 2016 and 2017 on virtual reality. The result was subjected to a correlation analysis that was supposed to provide us with answers to certain hypotheses. We compared the dependencies among the most searched terms within all available search categories with pre-selected subcategories. The subcategories have been defined after the analysis of the subject matter, which is found in the theoretical part. The correlation analysis was processed in IBM SPSS Statistics.

#### **3.1. Research hypotheses**

The analysis of the subject matter allowed us to formulate the following hypotheses:

- H1: In connection with the search for the term (vr) within the category internet and telecommunication, there is a statistically significant dependence.
- H2: In connection with the search for the term (vr) within the category shopping, there is a statistically significant dependence.
- H3: In connection with the search for the term (vr) within the category real estates, there is a statistically significant dependence.
- H4: In connection with the search for the term (vr) within the category business and industry, there is a statistically significant dependence.
- H5: In connection with the search for the term (vr) within the category games, there is a statistically significant dependence.
- H6: In connection with the search for the term (vr) within the category computers and electronics, there is a statistically significant dependence.

#### **3.2. Searching trend in Slovakia for virtual reality**

Google Trends has allowed us to focus on searching for concepts related to virtual reality that were most often searched for in Slovakia and whether or not the concepts were growing in the course of time. The most common criterion was defined as follows. These are the most popular themes. The scores were reported on a relative scale, where 100 indicates the most frequently searched topic, 50 represents the topic searched for by less than half the most popular topic. The Growth criterion was defined for related topics with the highest increase in search frequency since the last time period. The results marked by a huge change have made a huge increase. This criterion is also based on the assumption that the search for new themes in comparison with the past differs substantially with the subsequent increase in search. The Google trends website also offered choices from certain categories. The first was to focus on specific countries and we could then determine the time span of searches. Another category was the opportunity to choose from individual interest groups (e.g games, business and industry, computers and electronics, internet and telecommunication, business and real estates). Last but not least, we could also focus on the type of web search that has made us able to search for images, search in the news, google shopping, and youtube search.

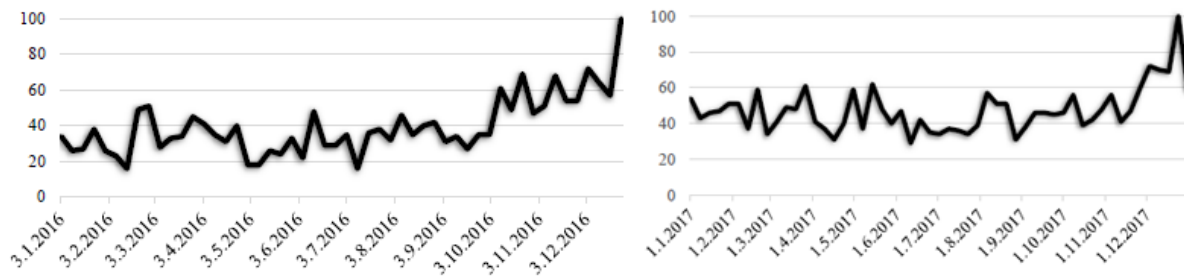

Chart 1: Development of the trend searching the 'VR' term in 2016 and 2017 on the Slovak market (own elaboration)

The individual values in the chart tell us how people have been dealing with the virtual reality over time. Individual values are in a relative shape where the value of 100 represents the highest popularity of the term. 50 means represent half popularity. Zero popularity means that there was not enough data for that term. The analysis of google trends has shown that 'VR' is clearly the most searched expression in the initials compared to other variants, such as 'virtual reality'. This difference was almost fourfold in favour of the term 'VR'. Since the data obtained from Google Trends did not meet the normal distribution, in our correlation analysis we used non-parametric variants, more specifically the Spearmen test. Google Trends offers us the opportunity to choose from the different interest subcategories, which in our case were subcategories such as the Internet and telecommunications, shopping, real estates, business and industry, games, computers and electronics. We have decided to determine the relevance of each subcategory in all categories.

Table 1: Correlation coefficients of selected categories for search term 'VR' (own processing)

VR in general	Correlation coefficient	Statistical significance
VR – Internet and telecommunication	0.186	0.183
VR – shopping	0.364	0.007
VR – reals estates	-0.097	0.489
VR – business and industry	0.173	0.216
VR – games	0.355	0.009
VR – computers and electronics	0.367	0.007

In all observed categories except for the property category, the correlation coefficient represents a positive correlation because the coefficient  $> 0$ . We have assumed such a result as we compared values across all categories including our selected subcategories. We must realize that the strong correlation between the two variables does not yet cause a causal relationship. Although a strong correlation can support the statement of a causal relationship, it is only one part of all the necessary evidence. Statistical significance level  $p = 0.05$ . Since for three categories the value of statistical significance is less than 0.05, we accept the H2, H5, H6 hypotheses and reject the H1, H3 and H4 hypotheses.

#### 4. CONSLUSION

In the analysis, we focused on the search trend through Google Trends. We were focusing on 2016 and 2017 because we have come to this end with a more integrated trend over the years. Firstly, we had to find out which concept was most searched for. The most searched term in connection with virtual reality was the term (vr). In Google Trends, we chose several of the most common categories that we suppose that had the most impact on search in the coming years. These were categories of games, business, industry, computers, electronics, the Internet and telecommunications, business and real estate. The result should indicate how much the term was searched for in selected interest groups. Only three categories were statistically significant.

It is clear from the correlation analysis that the topics that were searched for in virtual reality were mainly focused on games, computers, electronics and shopping. Being able to present our products or services through virtual reality became costly in recent years. In the coming years, this situation should change. That is why we support our view that companies will be able to take advantage of the overall potential of virtual reality in marketing in a relatively short time. This should be even more highlighted in those sectors that have proved to be the most significant in our research.

**ACKNOWLEDGEMENT:** *This article is one of the partial outputs under the scientific research grant VEGA 1/0806/16 – “Research on issues of consumer behaviour of a new generation of customers with emphasis on identifying preferences and usability of mobile platforms in the process of e-commerce of the subjects localized predominantly on the Central European Market” and VEGA 1/0789/17 – “Research of e-commerce with relation to dominant marketing practices and important characteristics of consumer behaviour while using mobile device platforms.”*

#### **LITERATURE:**

1. Alfalah, S. (2018). *Perception toward adopting Virtual Reality as a Teaching Aid in Information Technology*. USA: Springer. Journal of education and information technologies. 23(6). ISSN 1360-2357.
2. Augment, (2016). *The Difference Between Virtual Reality and Augmented Reality for Enterprise*. Retrieved 02-11-2018 from <http://www.augment.com/blog/difference-virtual-reality-augmented-reality-enterprise/>
3. Bramley, I. et al (2018). *Researching in-Store, at Home: Using Virtual Reality within quantitative Surveys*. London: Sage Publications. International Journal of Market Research, 60(4), ISSN 1470-7853.
4. Fraga, D. (2017). *The Story of Your Life is a Virtual Reality*. Retrieved 02-11-2018 from <https://vrscout.com/news/the-story-life-is-vr/>
5. Godin, S. (2006). *All Marketers are Liars*. USA: Portfolio. ISBN 80-7261-151-8.
6. Kim, J., Kang, S., Taylor, C.R. (2018). *Technology driven Experiences from Mobile Direct to Virtual Reality*. Oxon: Routledge Journals. Journal of Global Scholars of Marketing Science, 28(1), ISSN 2163-9159.
7. Mura, L. et al. (2017). *Empirical Results of Entrepreneurs' Network: Case Study of Slovakia*. University of Belgrade, Serbian Journal of Management, 12(1), ISSN 1452-4864.
8. Rovaglio, M., Scheele, T., (2010). *The Role of Virtual Reality in the Process Industry*. Retrieved 03-11-2018 from <http://software.schneiderelectric.com/pdf/white-paper/the-role-of-virtual-reality-in-the-process-industry/>
9. Ryte, W. (2016). *Search Volume*. Retrieved 04-11-2018 from [https://en.ryte.com/Search\\_Volume](https://en.ryte.com/Search_Volume)
10. Štefko, R., Gavurova, B., Korony, S. (2016). *Efficiency Measurement in Healthcare Work Management using Malmquist Indices*. Czestochowa, Poland. Polish Journal of Management Studies, 13(1), ISSN 2081-7452.
11. Vilčeková, L., Štarchoň, P. (2017). *Consumer Perception of Selected Brands Explored through Archetypes*. 4th International Conference on Education and Social Sciences (INTCESS), Istanbul. ISBN 978-605-64453-9-2.
12. Zion Market. (2017). *Global Smart Eyewear Technology Market Report*. Retrieved 04-11-2018 from [www.zionmarketresearch.com/report/smart-eyewear-technology-market](http://www.zionmarketresearch.com/report/smart-eyewear-technology-market)



## STATE AID IN THE EU AGRICULTURE

**Barbara Wieliczko**

*Institute of Agricultural and Food Economics – National Research Institute, Poland*

*Barbara.Wieliczko@ierigz.waw.pl*

### **ABSTRACT**

*The EU agriculture receives substantial support from the common agricultural policy. Yet, there are also member state instruments that are applied to remedy for certain market failures. To ensure fair competition on the EU single market the state aid offered by member states is subject to strict regulations limiting its scope and amount. The aim of the state aid for agriculture is to make up for market failures and to offer support in specific problematic situations faced by agricultural sector. The aim of this paper is to present the current rules related to the EU state aid in agriculture and show its extent and scope. Moreover, the paper tries to answer the question of the necessity of changes in the agricultural state aid given the planned alterations in the CAP and the challenges faced by the EU agriculture. The paper is based on the analysis of regulations related to state aid and the data on the scope and scale of the state aid applied by the EU member states. The results of the study show that there is still much room for simplification of the rules. Moreover, especially in the cases of plant and animal diseases it is worth considering whether the support should not be limited only to SMEs. Such situations are a serious problem not only to SMEs but to any enterprise and when not tackled properly can spread to other entities and endanger agricultural activity in whole regions or countries.*

**Keywords:** *common agricultural policy, EU agriculture, state aid*

### **1. INTRODUCTION**

The EU agricultural sector is mainly supported through the EU budget. Common agricultural policy (CAP) offers the same set of policy instruments for farmers from each of the EU member states. Yet, the member states have a certain freedom in choosing the measures they implement under pillar 2 of the CAP and the elements of the system of direct payments operating under pillar 1. Yet, apart of the EU funds for the agriculture individual member states offer their farmers some national policy instruments supporting this sector of the economy. In order to ensure fair competition on the EU single market granting of the state aid is strictly limited by the EU regulations<sup>1</sup>. Treaty on the Functioning of the European Union (TFEU) stipulates what is considered state aid in the EU. In its article 107 it is stated that following types of state aid are compatible with the EU internal market:

1. Aid having a social character, granted to individual consumers, provided that such aid is granted without discrimination related to the origin of the products concerned;
2. Aid to make good the damage caused by natural disasters or exceptional occurrences;
3. Aid granted to the economy of certain areas of the Federal Republic of Germany affected by the division of Germany, in so far as such aid is required in order to compensate for the economic disadvantages caused by that division.

---

<sup>1</sup> The safeguards for ensuring fair competition, apart from rules on state aid, include also regulations concerning prohibited forms of cooperation among economic entities. Treaty on the Functioning of the European Union in its article 101 prohibits agreements between two or more independent market operators which restrict competition. Yet, in the case of agricultural sector some forms of cooperation are exempt from this stipulation as the ones that improve the production or distribution of goods. Moreover, the article 42 of TFUE gives agriculture a special status. Therefore, certain forms of cooperation, not allowed in other sectors, are allowed in agriculture. Currently, detailed rules on these forms of cooperation are stipulated in the Regulation (EU) 1308/2013. In October 2018, based on this regulation the European Commission presented a report concerning the application of competition rules in the agricultural sector (European Commission 2018, COM(2018) 706).

This shows that only social care instruments for individual citizens and support offered to entities suffering damages caused by natural disasters is allowed. Yet, the same article also lists types of state aid that may be considered compatible with the internal market. These include:

- aid to promote the economic development of areas where the standard of living is abnormally low or where there is serious underemployment, and of the regions referred to in Article 349, in view of their structural, economic and social situation;
- aid to promote the execution of an important project of common European interest or to remedy a serious disturbance in the economy of a Member State;
- aid to facilitate the development of certain economic activities or of certain economic areas, where such aid does not adversely affect trading conditions to an extent contrary to the common interest;
- aid to promote culture and heritage conservation where such aid does not affect trading conditions and competition in the Union to an extent that is contrary to the common interest;
- such other categories of aid as may be specified by decision of the Council on a proposal from the Commission.

This list of support cases that may be compatible with the EU internal market shows that there is a whole range of situations when the state aid can be granted. However, it also hints at the need to prove that the support will not affect the functioning of the EU single market. Therefore, apart from these stipulations there are detailed rules related to state aid. Moreover, the European Commission (EC) has a set of common assessment principles for state aid applied to evaluate the compatibility of a proposed state aid instrument with the TFUE. These principles, inter alia, include verification of the proportionality, transparency and avoidance of major undue negative effects on competition and trade between member states. The EU rules on state aid are subject to periodic modifications. They include general rules and principles as well as sector specific rules taking into account the specificity of different parts of the EU economy. Generally, they specify how economic entities can be supported by member states when the natural or economic conditions hinder or endanger continuation of their economic activity. The aim of this paper is to present the current rules related to the EU state aid in agriculture and show its extent and scope. Moreover, the paper tries to answer the question of the necessity of changes in the agricultural state aid given the planned alterations in the CAP and the challenges faced by the EU agriculture. The paper is based on the analysis of regulations related to state aid and the data on the scope and scale of the state aid applied by the EU member states.

## **2. LEGAL FRAMEWORK OF THE EU STATE AID FOR AGRICULTURE**

An important legal base for the support of the agriculture in the EU is the article 42 of the TFUE. It envisages for the production and trade of agricultural products possibility of supporting enterprises handicapped by structural or natural conditions and aid offered within the framework of economic development programmes. Based on the article 108(4) of the TFUE, the EU adopted block exemption regulations. Under these regulations the state aid offered to specific types of entities or for specific purposes does not require member state notification to the EC. They include, inter alia, small and medium enterprises, research and development or promotion of food sector products not listed in Annex I of the TFEU (Council Regulation (EU) 2015/1588). There is also the Commission Regulation (EU) No 651/20147, known as the General Block Exemption Regulation (GBER). It enumerates the categories of aid which can be exempted from the notification requirement of Article 108(3) of the TFUE. A special regulation concerning block exemptions in the agricultural sector is also in force. It is generally referred to as Agricultural Block Exemption Regulation (ABER) (Regulation (EU) 702/2014). Moreover, the European Commission published Guidelines for State aid in agriculture and forestry (agricultural GL).

They present criteria that the EC applies when assessing member states applications for state aid in agriculture and forestry that are subject for notification. Thus, these guidelines apply to the case that are not within the scope of article 42 of the TFUE, ABER or de minimis. The ABER procedure offers the member states a fast track introduction of new state aid instruments. They can be accepted within 10 working days, while the notification procedure lasts at least half a year. The types of state aid that do not require prior notification by the EC include:

- aid in favour of SMEs active in primary agricultural production, the processing of agricultural products and the marketing of agricultural products;
- aid for investments in favour of conservation of cultural and natural heritage located on agricultural holdings;
- aid to make good the damage caused by natural disasters in the agricultural sector;
- aid for research and development in the agricultural and forestry sectors;
- aid in favour of forestry;
- aid in favour of SMEs in rural areas co-financed by the EAFRD or granted as additional national financing to such co-financed measures.

There are also regulations related to a limited aid named de minimis. We have both a general de minimis regulation applied to all sectors (regulation 1407/2013) and regulation for agriculture (regulation 1408/2013). Currently, a farm can receive up to EUR 15,000 during a three year period. It must also be mentioned that that the support offered within the EU cofinanced rural development programmes is not considered a state aid. The current framework of regulations related to the state aid in agriculture is presented in figure 1. As shown in figure 1, the system of state aid for agriculture is complex. Its design is closely linked to the CAP. It can be stated that the state aid in its scope and scale acts as a complement to the CAP measures, especially the rural development measures regulated by the Regulation (EU) 1305/2013.

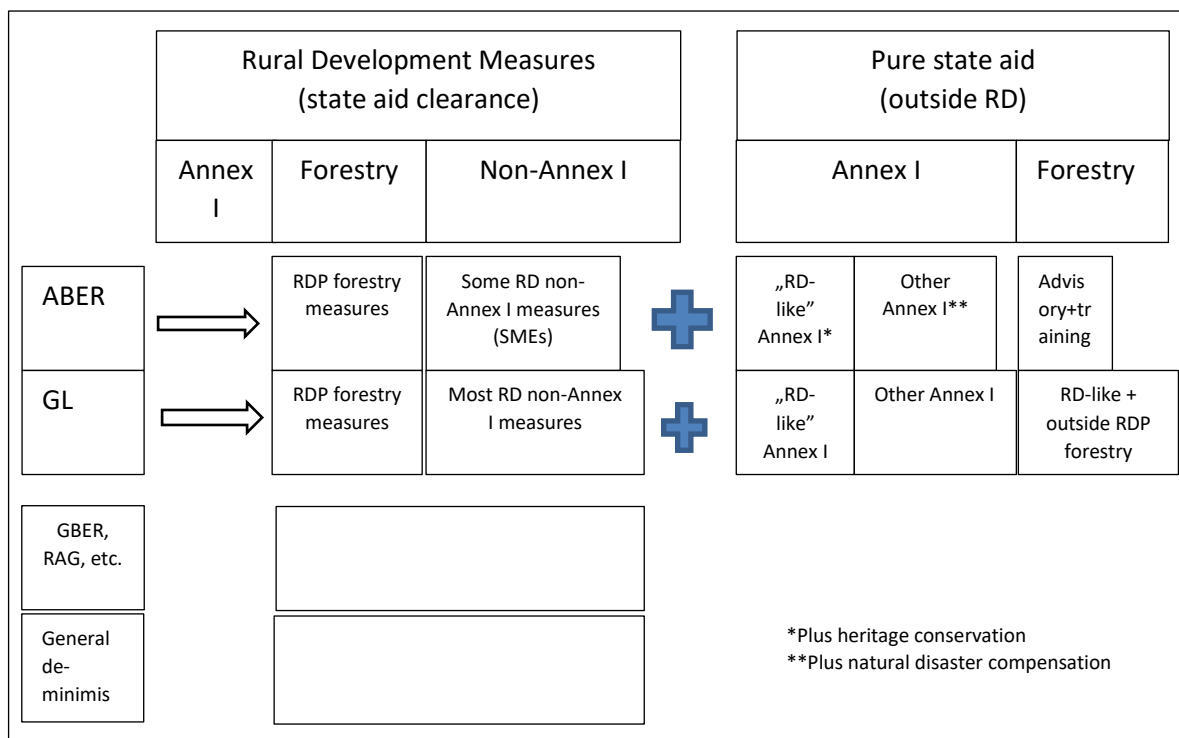

Figure 1: Current framework of the EU state aid for agriculture (European Commission, 2014, fig. 1)

### 3. SCALE AND STRUCTURE OF THE EU STATE AID FOR AGRICULTURE

Member states vary in the scope and scale of the support they offer to their agricultural sectors within the state aid. In fact, there are no clear patterns in the member states' use of the agricultural state aid. Yet, it may be stated that if a member state does offer substantial state aid support for its agricultural sector it does that to make up for lack of specific support or insufficient support for the agricultural sector offered within the scope of the CAP. A vivid example of such a behaviour is Finland. It is a country with especially visible natural constraints to conducting agricultural activity. Therefore, it makes a significant use of state aid to complement the CAP measures in order to keep its farming sector. The state aid for agriculture is low compared to the CAP spending as it amounts to 0,04% of the EU GDP (table 1), while the CAP to app. 0,3% of the EU GDP. This shows that the CAP acts as the key policy for farming in the EU and that member states through state aid only supplement its efforts to support the development of agriculture. Clearly, the most important beneficiary of the state aid measures is the German agricultural sector as it receives one fifth of the state aid granted by the EU member states for the support of agriculture. The second member state to be significant user of the state ad for agriculture is Italy, while among the new member states Poland has the largest share in the total state aid spending. When we look at the spending expressed as a share of the GDP it is clear that the newest EU member spends the most. This is typical of new member states which in the first years of the EU membership keep most of their previous agricultural policy instruments. The second place in this ranking is occupied by Finland which tries to support agriculture in significantly unfavourable climatic conditions.

Table 1: State aid for agriculture in the EU member states in 2016 (own elaboration based on DG Competition's data)

Member state	As % of GDP	in EUR million	As % of EU state aid for agriculture	Member state	As % of GDP	in EUR million	As % of EU state aid for agriculture
Austria	0.04	150.6	2.76	Italy	0.04	679.0	12.43
Belgium	0.01	40	0.73	Latvia	0.08	18.7	0.34
Bulgaria	0.13	63.5	1.16	Lithuania	0.03	12.8	0.23
Croatia	0.20	90.0	1.65	Luxembourg	0	1.8	0.03
Cyprus	0.05	8.8	0.16	Netherlands	0.08	537.0	9.83
Czechia	0.14	240.0	4.39	Poland	0.06	273	5.00
Denmark	0.03	93.0	1.70	Portugal	0.03	49.5	0.91
Estonia	0.05	9.8	0.18	Romania	0	4.4	0.08
Finland	0.16	351.7	6.44	Slovakia	0.03	24.4	0.45
France	0.02	513.1	9.39	Slovenia	0.01	5.5	0.10
Germany	0.04	1113.8	20.38	Spain	0.05	515.3	9.43
Greece	0.05	79.7	1.46	Sweden	0	18.8	0.34
Hungary	0.16	177.9	3.26	UK	0.01	247.5	4.53
Ireland	0.05	145.1	2.66	EU	0.04	5464.7	100.00

As the amount and the scale of the state aid offered to agriculture varies among the EU member state so do also the instruments implemented. Therefore, in 2016 at the EU level the structure of state aid included almost 40 different titles for support (table 2). This shows the diversity of needs among the member states. The most important measure based on its share in the total EU agricultural state aid spending are the tax exemptions under Directive 2003/96/EC. Yet, their importance decreased in 2016 due to the fact that the EC decided that in some member states this support should not be enlisted as support for the agriculture and it is no longer reported as

agricultural state aid. This is the case, inter alia, of Poland and France. Also insurance premiums and forestry are an important part of the agricultural state aid spending.

*Table 2: Structure of state aid for agriculture in the EU member states in 2016 (own elaboration based on DG Competition's data)*

Measure	Share	Measure	Share
Research and development	0.87	Insurance premiums	6.35
Adverse climatic events	0.05	Investment in agricultural holdings	1.38
Sectoral development	2.46	Investment in processing and marketing	1.18
Risk and crisis management	1.66	Land reparcelling	0.11
Rural development	0.36	Livestock sector	0.33
Compensation of damages caused by natural disaster	6.13	Natural disasters or exceptional occurrences	0.67
Adverse weather conditions	0.37	Outermost regions and the Aegean Islands	0.50
Agri-environmental commitments	3.17	Payments Natura 2000 and payments linked to the Directive 2000/60/EC	0.55
Advertising	0.95	Plant diseases and pest infestations	0.02
Animal diseases	1.80	Producer groups	0.01
Animal welfare commitments	2.70	Production quality agricultural products	0.01
Closing capacity	0.02	Relocation of farm buildings	0.02
Conservation of traditional landscapes	0.26	Remedy for a serious disturbance in the economy	0.00
Early retirement	2.67	Restructuring firms in difficulty	0.04
Encouraging quality products	0.32	Setting up of young farmers	0.16
Environmental protection	2.94	Start-up of producers groups	0.02
Horizontal aid instruments agriculture sector	0.05	Tax exemptions under Directive 2003/96/EC	9.88
Handicaps in certain areas	0.02	Technical support	0.59
Forestry	5.41	Other	3.60

Other issue worth presenting is the number of agricultural state aid cases depending on the procedure. Most of the state aid cases were implemented based on the simple procedure of block exemptions. In the period 2015-2016 the number of block exemption cases in the agricultural sector was almost six times larger than the notified aid cases (table 3).

*Table 3: Number of agricultural state aid cases registered or notified in the period 2015-2016 (own elaboration based on ADE, 2018, table 6)*

Number of cases according to the procedure	2015	2016	Total
XA - agriculture block exemption	591	402	1.241
N - notified aid cases	88	107	213
Total	679	509	1.454

There are also different types of the aid offered. We distinguish among schemes, ad hoc cases and individual applications. Individual application is the aid offered to single companies. An example of such a state aid case is the Polish state support for a company Polhoz Sp. Z o.o.. The state aid case SA.47062 (2016/XA) is the aid for the costs of the prevention and eradication of animal diseases and plant pests and aid to make good the damage caused by animal diseases and plant pests (Article 26 of ABER). Public aid was granted to an individual company as a support for a damage caused by appearance of a quarantine organism. Most of the state aid measures are schemes, yet there are also ad hoc cases (table 4).

*Table 4: Distribution of State aid cases according to type (own elaboration based on ADE, 2018, table 7)*

Number of cases under GL or ABER according to their type	2015		2016		Total	
	GL	ABER	GL	ABER	GL	ABER
Scheme	92	574	108	378	217	1.196
Ad Hoc Case	1	17	1	24	2	45
Individual Application	2		4		8	
Total	95	591	113	402	227	1.241

When we divide state aid cases into certain categories based on the rationale for support we can see that insurance premiums and animal and plant diseases are very common reasons for granting support to farmers (table 5). Also the amounts spent on the measures related to diseases and insurance premiums were in the analysed period the highest. For the diseases prevention and irradiation it was over EUR 800 million and for the insurance premiums it was over EUR 706 million (ADE, 2018, table 10).

*Table 5: Distribution of state aid cases based on the GL and ABER among the specific aid measures (own elaboration based on ADE, 2018, table 8 and 9)*

Categories of state aid measure	2015		2016		Total	
	GL	ABER	GL	ABER	GL	ABER
A1 adverse climatic events	4*	8	5	11	9	19
A2 animal diseases & plant pests	4	68	4	43	1	111
A3 fallen stock	0	14	1	7	1	21
A4 damage by protected animals	2	0	7	0	9	0
A5 insurance premiums	4	88	1	35	5	123
B1 forest fires, adverse climatic events	5*	25	5	21	10	46
B2 investment (process. mobilis. marketing)	2	15	1	17	3	32
C1 agri products into non-agri products	0	9	2	11	2	20
Other measures	75	398	87	284	162	682
Total	96	625	113	429	202	1044

*\*multiple aim measures*

#### 4. CONCLUSION

The regulations on state aid in agriculture are periodically revise to take into account the changes in the CAP and situation in the agricultural sector. An example of this is the so-called omnibus regulation which contributed to some simplification of rules governing CAP and state aid (Regulation (EU) 2017/2393). The EC has already entered a period of analysing the application of the regulations currently in force to identify the necessity and scope for further modifications and alterations. The first proposal presented by the EC was the concept of increasing the amount of aid that can be offered as de minimis support. In spring 2018 the EC launched public consultations on increasing the amount from EUR 15,000 per farm within 3 years to EUR 25,000. Moreover, this proposal also included the augmentation of the national maximum amount of aid from the current ceiling of 1% to 1.5% of the annual agricultural output over the same three-year period. An interesting rule was also included in this proposal. The EC calls for setting the total amount of aid that can be granted by member states to any particular branch of the agricultural sector. This limit should be 50% of the national maximum amount. It is proposed as a mechanism to reduce the impact on trade between member states and avoid potential distortion of competition. Another novelty of the EC's proposal is the creation of mandatory central registers at member state level kept to records the de minimis aids granted in order to simplify and improve the delivery and monitoring of de minimis aid.

It must be said that the lack of interest in the consultation process is astonishing given the constant calls for increasing the public support for agriculture that are made by the agricultural organisation. Also member states, apart from Czech Republic, did not take part in these public consultations. Maybe the lack of participation in the consultations was a result of the ongoing debate on the future of the CAP and the willingness of all the stakeholders to focus on the much larger and therefore more important issues of the CAP and the division of its budget. The climate changes result in increasing numbers of natural disasters and adverse climatic events that cause losses in agriculture that put in danger the continuation of agricultural activity by numerous farms. Moreover, despite the efforts for developing risk management systems and encouraging farmers to get insurance, the system of managing risks in the EU agriculture is almost non-existent. Therefore, the need for state aid can only increase. As the adverse natural phenomena, as well as animal and plant diseases (also often more common, wilder spread and more persistent due to climate changes) are not limited to agricultural entities that are part of SMEs sector, also big agricultural entities should be allowed support in such cases. This is especially relevant in the case of animal and plant disease eradication and prevention as the spread of any diseases can put in danger specific branches of agricultural sector in the whole regions or even states and can become an EU-wide problem when it comes to trade and potential bans of specific EU products due to such diseases. An in-depth analysis of the current regulations of the state aid for agriculture shows that there is still much scope for simplifications. Yet, it can be expected that the process of simplifying the rules will not be easy as it must also ensure that state aid rules do not distort fair competition and are fully transparent. Moreover, it cannot be undertaken separately from the rules and simplification processes related to the regulations on the CAP. Therefore, it cannot be expected to be conducted soon as the regulations for the CAP 2021-2027 are being prepared and the EC does not envisage in its work plan for 2019 (European Commission 2018, COM(2018) 800).

#### **LITERATURE:**

1. ADE (2018). *Evaluation study of the instruments applicable to State aid in the agricultural and forestry sectors and in rural areas. First Interim Report*. Report commissioned by the European Commission. Luxembourg: Publications Office of the European Union (forthcoming).
2. *Commission Regulation (EU) No 651/2014 of 17 June 2014 declaring certain categories of aid compatible with the internal market in application of Articles 107 and 108 of the Treaty*. Official Journal of the European Union L 187, pp. 1-78.
3. *Commission Regulation (EU) No 702/2014 of 25 June 2014 declaring certain categories of aid in the agricultural and forestry sectors and in rural areas compatible with the internal market in application of Articles 107 and 108 of the Treaty on the Functioning of the European Union*. Official Journal of European Union L 193, pp. 1-75.
4. *Commission Regulation (EU) No 1407/2013 of 18 December 2013 on the application of Articles 107 and 108 of the Treaty on the Functioning of the European Union to de minimis aid Text with EEA relevance*. Official Journal of the European Union L 352, pp. 1-8.
5. *Commission Regulation (EU) No 1408/2013 of 18 December 2013 on the application of Articles 107 and 108 of the Treaty on the Functioning of the European Union to de minimis aid in the agricultural sector*. Official Journal of the European Union L 352, pp. 9-17.
6. *Council Regulation (EU) 2015/1588 of 13 July 2015 on the application of Articles 107 and 108 of the Treaty on the Functioning of the European Union to certain categories of horizontal State aid (Text with EEA relevance)*. Official Journal of the European Union L 248, pp. 1-8.

7. European Commission (2014). *Commission Staff Working Document, Impact Assessment, Accompanying the document "European Union Guidelines for State aid in the agricultural and forestry sectors and in rural areas 2014 to 2020" and "Commission Regulation declaring certain categories of aid in the agricultural and forestry sectors and in rural areas compatible with the internal market in application of Articles 107 and 108 of the Treaty on the Functioning of the European Union"*. SWD(2014) 196 final.
8. European Commission (2018). *Communication from the Commission to the European Parliament, the Council, the European Economic and Social Committee And The Committee of the Regions Commission Work Programme 2019. Delivering what we promised and preparing for the future*. COM(2018) 800 final.
9. European Commission (2018). *Report from the Commission to the European Parliament and the Council the application of the Union competition rules to the agricultural sector*. COM(2018) 706 final.
10. *Regulation (EU) 1305/2013 of the European Parliament and of the Council of 17 December 2013 on support for rural development by the European Agricultural Fund for Rural Development (EAFRD) and repealing Council Regulation (EC) No 1698/2005*. Official Journal of the European Union L 347, pp. 487-548.
11. *Regulation (EU) 2017/2393 of the European Parliament and of the Council of 13 December 2017 amending Regulations (EU) No 1305/2013 on support for rural development by the European Agricultural Fund for Rural Development (EAFRD), (EU) No 1306/2013 on the financing, management and monitoring of the common agricultural policy, (EU) No 1307/2013 establishing rules for direct payments to farmers under support schemes within the framework of the common agricultural policy, (EU) No 1308/2013 establishing a common organisation of the markets in agricultural products and (EU) No 652/2014 laying down provisions for the management of expenditure relating to the food chain, animal health and animal welfare, and relating to plant health and plant reproductive material*. Official Journal of the European Union L 350, pp. 15-49.
12. *Treaty on the Functioning of the European Union* (2008). Official Journal of the European Union C 115, pp. 47-199.



## TWO SCENARIOS OF FINANCIAL ACTIVATION OF THE GUARANTEED MINIMUM INCOME RECIPIENTS, IN TERMS OF REDUCING POVERTY IN ROMANIA

**Cristina Stroe**

*National Scientific Research Institute for Labour and Social Protection, Romania  
cristinaradu@incsmpps.ro*

**Codruta Dragoiu**

*National Scientific Research Institute for Labour and Social Protection, Romania  
cdragoiu@incsmpps.ro*

**Andreea Cambir**

*National Institute of Statistics, Romania  
cristinaradu@incsmpps.ro*

### **ABSTRACT**

*The Guaranteed minimum income is one of the most important social programs that prevent and reduce poverty and social exclusion in Romania. Prior to its implementation in 2002, sustained concerns to improve this social program existed. In recent years, efforts to reduce poverty have been increasing by introducing financial activation elements within the guaranteed minimum income to stimulate employment among its beneficiaries. The current law on guaranteed minimum wage includes such an activation component, but it was found, however, that this is not stimulating, as the beneficiaries are not thus encouraged to find a job and get out of the social care network. As a more pronounced activation of the guaranteed minimum income recipients is desired in the recent years, the present paper proposes two exercises of simulation, namely the introduction of this incentive support within the Guaranteed minimum income (two simulation scenarios, one pessimistic and another optimistic, respectively with two thresholds of 35% and 65%), to analyze the degree to which poverty incidence would be reduced among these recipients. The two impact assessment exercises will be carried out using the classic simulation model, based on HBS/Household Budget Survey data. Considering these financial activation elements, poverty rates will be calculated in each of the two scenarios to analyze to what extent these pro-active components, upon its insertion in the guaranteed minimum income, would contribute to poverty reduction among social aid beneficiaries. These simulations could provide some basic guidelines to be subsequently improved and supplemented, helping to improve this social assistance benefit concerning the Guaranteed minimum income, while promoting and enhancing the employment and social inclusion among the beneficiaries of this important social policy.*

**Keywords:** *Activation financial elements, Guaranteed minimum income, Impact evaluation, Relative poverty, Simulations scenarios*

### **1. INTRODUCTION**

The Guaranteed minimum income is one of the most important social programs that prevent and reduce poverty and social exclusion in Romania. Prior to its implementation in 2002, sustained concerns to improve this social program existed. The current law on guaranteed minimum income, Law no. 416/2001, with all subsequent amendments, provides support for vulnerable people, ensuring a social benefit depending on income, number of family members and a list of goods (that can lead to the exclusion of the applicants from the list of recipients of this benefit). Regarding the work incentive, the law specifies that the family allowance is increased by 15% if at least one of its members is employed and receives a salary income.

Article 11 of Law no. 196/2016 regarding the minimum inclusion income, which will come into force on April 1, 2019 (GEO no. 82/2017), provides a more active and attractive incentive for the beneficiaries from the perspective of their involvement in the labor market, respectively: "In order to encourage an active life and the participation in the labor market, when one or more family members obtain an income from an individual employment contract, an employment relationship or other legal form of employment, or are self-employed or in agricultural activities, 50% of the total, but not more than 400 lei / family, respectively social reference indicator (a national benchmark) 0,800 ISR is taken into account in determining the family monthly net incomes." For beneficiaries, increased work incentives and a reduction of poverty rates are considered in the new social benefits regulations of the guaranteed minimum income (currently), respectively minimum inclusion income (in the future). We believe that such support and encouragement of the employment of beneficiaries through the increase of the work incentives by switching from the addition of 15% to the amount of family allowance (if at least one of its members is employed and obtains a salary income), to not taking into account - when determining the family net monthly incomes - a certain percentage of labor income for those families where at least one of the members earns salary income, would be more encouraging for beneficiaries in their process of obtaining a job. Thus, for real improvement and modernization of the social assistance benefits system, as other countries have already done and in accordance with the action directions of the National Strategy on Social Inclusion and Poverty Reduction 2015-2020 (Emergency Government Ordinance no. 383/2015), the Strategic Action Plan for the period 2015-2020 and also of the European Strategy 2020 it is necessary to have work incentives in social welfare programs, especially on the guaranteed minimum income. This improvement process is expected to limit the excessive dependence on the social assistance system and stimulate employment of its beneficiaries. At the same time, the present paper is considering an analysis of the most important benefit of social assistance provided for the prevention and combating of poverty and the risk of social exclusion, according to the taxonomy in the Law no. 292/2011 on social assistance, with all subsequent amendments. The paper will analyze aspects related to the adequacy of the guaranteed minimum income for its main purpose, that of reducing poverty among the vulnerable ones and at the same time adjusting the guaranteed minimum income to the size of the activation, namely to encourage its beneficiaries to become employed in terms of reducing poverty among the beneficiaries of the guaranteed minimum income, taking into account the insertion of some work incentives within this important social assistance program.

## **2. THE STRATEGIC FRAMEWORK AND THE LITERATURE**

Combating poverty has been one of the most important objectives of the social policy promoted by EU Member States. Establishing the objectives, the action lines, identifying tools and implementing the policies to combat poverty and increase social inclusion are key elements in ensuring a minimum level of resources for vulnerable people facing the main social risks. A major moment in the evolution of social policy took place in 2000, when the Lisbon Strategy was elaborated. Lisbon Strategy established the objective of the European Union within a ten-year timeframe: the transformation of the EU economy into the most competitive knowledge-based economy. The Social Policy Agenda, adapted in 2000, has taken over those specific objectives and elements of the social policy strategy and has converted them into a five-year action program that has been the framework for the current social policy. Thus, the Lisbon Summit of March 2000, which emphasized the role of social policy in the development of the EU, decided to launch the European cooperation to promote social inclusion, to combat poverty and social exclusion, proposing the "open method of coordination" as a working method and the eradication of poverty by 2010. The Europe 2020 Strategy - The EU's economic growth strategy for 2010-2020 is the successor of the Lisbon Agenda.

Starting from the achievements of the Lisbon Agenda, The Europe 2020 Strategy brought new elements to support the effects of the economic crisis started in 2008. Thus, five major objectives to be achieved by 2020 (employment, innovation, education, social inclusion and environment / energy) have been established. Regarding social inclusion, the European Union aims to reduce the number of people at risk of poverty and social exclusion by 2020. Prior to these strategies, a particular emphasis on poverty reduction was made, recalling that Marshall (1950) "placed the guarantee of minimum incomes at the core of social citizenship rights", while also Rawls (1971), "recognized the importance of last-resort safety nets in the form of a social minimum, but for the creation of just societies". Thus, the social dimension has always played an essential role not only in national and international/ European policies and strategies, but also in the scientific literature, trying to find solutions for poverty reduction and to increase social and occupational inclusion among persons facing these social risks. Nowadays too there is a particular emphasis on supporting vulnerable populations in poverty. Thus, other papers also analyze the guaranteed minimum income and monetary incentive, estimating these monetary gains to employment for welfare program. Thus, Gurgand and Margolis (2005) started from the hypothesis according to which, "Most welfare programs generate high marginal tax rates on labor income. This paper uses a representative sample of individuals on France's main welfare program (le Revenu Minimum d'Insertion, or RMI) to estimate monetary gains to employment for welfare recipients. This is based on the distribution of potential monthly earnings faced by each individual, as inferred from the distribution of observed wages and working time". The conclusion of the paper was that taking account of the welfare earnings top-up program, the gains are almost always positive. Figari, Matsaganis, and Sutherland (2013), as well as other prestigious experts in using the EUROMOD microsimulation model, explored and compared the effectiveness of Minimum Income MI schemes for persons of working age in the European Union, and they appreciated that using the European micro simulation model EUROMOD, they estimated indicators of coverage and adequacy of MI schemes in 14 EU countries. In that study, the findings of the experts pointed out that "In terms of coverage, we found that in several countries, some individuals are ineligible for MI even when they fall below a poverty line set at 40 per cent of median income. With respect to adequacy, we show that in certain countries, a large fraction of those entitled to MI remains at very low levels of income even when MI benefit is added". More and more often, efforts to reduce poverty move from total and passive support, social assistance to those in need, to an active support: new active initiatives to stimulate the employment of the beneficiaries and thus to reduce poverty by increasing the incomes. Therefore, more and more emphasis are placed on the activation character of the beneficiaries of social support, to support them to take a job, to earn their own employment income and not to be places in the social welfare net. The present paper also examines the extent to which a certain amount of work incentives would reduce poverty among beneficiaries of guaranteed minimum income. In this regard, this paper presents two simulation scenarios, one pessimistic and another optimistic, for providing a lower or a higher percentage than the one to come into force in April 2019, in order to predict to what extent each one of the two scenarios would reduce relative poverty among beneficiaries of the guaranteed minimum income. Unfortunately, the model could not consider the budget effort (other models manage to measure this effort, e.g. the EUROMOD microsimulation model) or other particularly relevant indicators, such as an estimation of the number of beneficiaries that could be stimulated in employment after applying for a guaranteed minimum income under the new work incentives. The new pro-active conditionality was simulated by introducing activation elements in the guaranteed minimum income, with a certain percentage of labor income (testing the eligibility), which stimulate work and at the same time reduce the relative poverty, calculated at the 60% threshold of median income per adult equivalent. The paper focuses on two simulation thresholds: when family income does not consider the 35% of the labor income

(minimum threshold) and when family income does not consider the 65% of the labor income (maximum threshold). These two extreme thresholds (when a less discouraging stimulation and a more pronounced one are envisaged in the transition to employment) that accompany the two variants, the pessimistic and the optimistic ones, would be not only more motivating for employability, much more than it is currently, but also contribute to poverty reduction. An International Labor Office (ILO) document (2015) mentions briefly “the active solidarity income from France (le revenu de solidarité active) that provides a minimum income and measures aimed at supporting employability and return to work for the working poor and unemployed who receive insufficient income replacement”. According to the document, the French legislation on the active solidarity income (RSA): “when recipient works, even part time, the Floor RSA is reduced and an Activity RSA is added on to ensure that the total income (composed of Floor RSA, Activity RSA, and earnings) equals the minimum income guarantee (MIG). This MIG is the Floor RSA plus 62 per cent of the earnings up to a threshold that is approximately the minimum wage for a single person”. This is what led to the idea presented in the paper, that of setting an upper limit of 65% to the threshold, that we had in mind at the national estimates for inclusion in the guaranteed minimum income program. In 2017 the Government of Ontario, Canada, has initiated a pilot project in three regions, that included, among other points, a number of participants (4000 individuals between 18-64 years, for a total population of those regions around 665 thousand persons) that were either assigned to a control or a treatment group. Those in the treatment group will be eligible for the following benefits, to be paid in cash:

- Up to \$16,989 per year for a single person (with the amount reduced by 50% of the amount of any income earned on top of the benefit).
- Up to \$24,027 per year for a couple (with the amount reduced by 50% of the amount of any income earned on top of the benefit).
- Up to an additional \$6,000 per year for a person with a disability.

This basic income pilot has many hypotheses and conditionalities, but it is also very much appreciated by other major provinces in this country, whose representatives have also expressed considerable interest. The BIEN / Basic Income Earth Network (2017) does not only mention Canada’s experiment, in terms of social assistance, but also the Danish experiment. The Dutch Ministry of Social Affairs authorized experiments in the first five municipalities. According to the BIEN report, “Subjects assigned to the third treatment groups will be permitted to retain 50% of additional earned income, up to a maximum of euro 199 per month, for the duration of the two-year experiment. In contrast, under current policy, welfare recipients are permitted to keep only 25% of additional income and only for up to six months”. Thus, more and more countries put a strong emphasis on pro-active conditionality that is inserted in guaranteed minimum income schemes or social assistance schemes, and by pilot experiments or simulations new ways for activating its beneficiaries are looked for.

### **3. THE METHODOLOGICAL FRAMEWORK FOR EX-ANTE EVALUATION AND SIMULATION OF POVERTY REDUCTION IN TERMS OF INTRODUCING SOME HYPOTHETICAL THRESHOLDS FOR EMPLOYMENT STIMULATION IN THE GUARANTEED MINIMUM INCOME**

The introduction of such pro-active elements in the program on guaranteed minimum income and subsequently in the minimum inclusion income, which will provide, besides its main purpose to support the poorest people, a real activation of the beneficiaries, would consist in an important direction of action to improve, modernize and streamline this important benefit of social assistance. At the same time, we estimate that these new coordinates inserted in the guaranteed minimum income could have some impact on poverty reduction that would be a

plus for the initiated reform. The data source used was the Family Budget Survey ABF / National Institute of Statistics, conducted in 2014 (the last available year) - processing carried out by the National Center for Statistics Preparation / National Institute of Statistics. Relative poverty rate is an indicator of poverty that represents the share in the total population of people in households with disposable income per adult equivalent (including or excluding the value of consumption from own resources) below poverty line. This indicator is determined for the threshold of 60% of the median of the available income per adult equivalent. In the simulations, we started from the condition that, in households where there are employed persons, the income test threshold would take into account these proportions of the work income, as follows:

$$T_{I1} = T_{I0} - p * I_w$$

where:

$T_{I1}$  represents the new household income for households in which there is at least one employed person;

$T_{I0}$  is the currently income of the household in place for testing the eligibility for guaranteed minimum income;

$p$  is the proportion of work income to be taken into account when establishing the new household's income (in this paper we tested two proportions: - one minimal threshold of 35% and one maximal of 65%); and

$I_w$  represents the Income from work.

The maximal threshold of 65% of the work income not taken into account when determining the monthly family net income for the eligibility to the guaranteed minimum income was inspired by the French model, where "the final income guaranteed to the recipient is calculated by adding a proportion equal to 62% of his or her income from employment", according to Legros (2009). The eligibility conditions that were taken into account in the simulations were as follows:

- testing, if there is at least one employed person in each household, if YES then to the existing guaranteed minimum income (threshold 0) the "p" proportion is applied;
- for people having a guaranteed minimum income, but there are no employed persons in the household, the existing value has been preserved.

#### **4. THE SIMULATION RESULTS OF THE 2 SCENARIOS**

The ex-ante simulations / evaluations for two scenarios were considered: Scenario I, when a proportion of 35% of labor income is not taken into consideration in the income of households having employed persons (pessimistic scenario) and Scenario II when the proportion is that of 65% (optimistic scenario). Simulated poverty rates were calculated for the two scenarios and then they were compared to the real poverty rate. Thus, it was possible to highlight the relative change in the poverty rate for each of the envisaged variants / scenarios (Figure 1).

*Figure following on the next page*

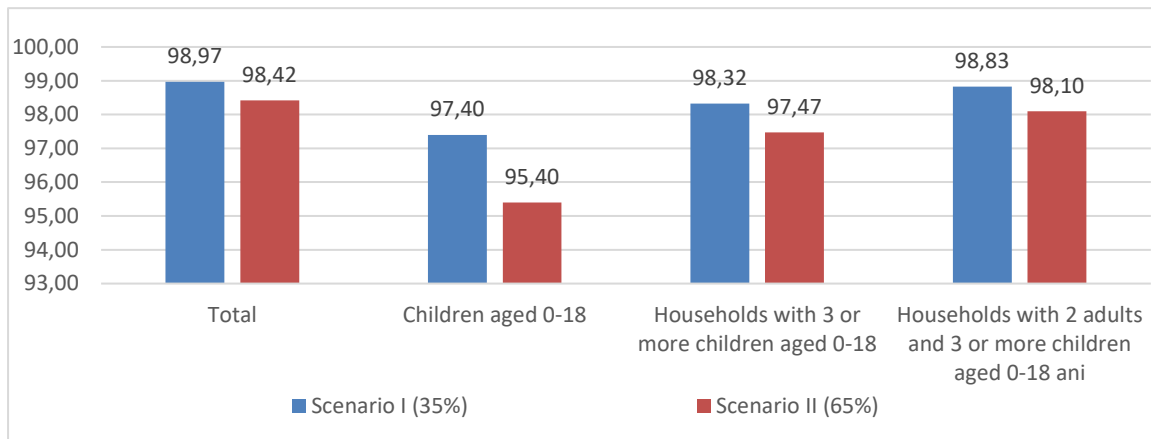

*Figure 1: Relative change of the poverty rate (%) for the two scenarios, when specific activation components are inserted in the available income [statistical processing of the Household Budget Survey, National Institute of Statistics, Romania, 2014]*

When in the tested income of the households having employed persons, 35% of labor income is not taken into account (Scenario I), this would influence the poverty rate by 98.97% for the entire population, as when the income of the household does not take into account the proportion of 65% of the labor income of the employed person (Scenario II), the poverty rate is slightly more influenced, respectively, by 98.42%, in the entire population. In terms of any of the two scenarios, even the pessimistic one, the relative poverty rate is reduced when in the household income an activation element is taken into account, even if there is a low percentage (e.g. 35%). Poverty reduction is more important when a higher proportion of labor income is not taken into account in the household's total income for testing eligibility to the guaranteed minimum income for those household with employed people. Thus, the more stimulating and tending to a higher threshold the proportion is, the more the relative poverty rate decreases, even if the reduction is not particularly significant. More distinct differences than those found across the population can be seen for some types of households. For example, higher poverty reductions and relatively important changes in poverty rates occur among children aged 0-18 years in both scenarios, but also for large households with three or more children in care. In the case of the pessimistic scenario, when the 35% is not taken into account in the income, among children aged 0-18 years, the relative change in the poverty rate is 97.40%, while for those households with three or more children aged 0-18 years, the relative change in the poverty rate is higher, of 98.32%. Regarding the optimistic scenario, when 65% of the income is not taken into account, among children and households with children aged 0-18 years, the relative change in the poverty rate is much more visible, of 95.40% (children) or 97.47% (households with children), which means an important effect when it comes to those households that have dependent children. Regardless of the scenario taken into consideration, even in the case of the pessimistic one, an aspect is clearly highlighted: poverty is reduced by a certain percentage when the income includes a more significant activation component than the present one (when 15% is added to the social assistance benefit, when a member of the beneficiary family is employed and receives a salary income). In both scenarios, simulated poverty rates for both total population and many types of households, especially for those who have one or more dependent children (and for which it is well known that they are facing increased poverty) shows a significant trend of decreasing poverty in the presence of these employment incentives that are included in the guaranteed minimum income. In simulation exercises, simulated rates have highlighted the fact that poverty reduction is greater as a higher percentage of work income is not taken into account in determining net household income for the eligibility to the guaranteed minimum income program, namely the greater and more stimulating the incentive

is. It can be concluded that both employment incentives from the two scenarios, which take into account one proportion or the other of the work income taken into consideration when establishing the new income threshold for the beneficiaries of the guaranteed minimum income, regardless of the 35% or 65% proportion of work income, it is certain that the incidence of poverty is decreasing compared to the present. Thus, the higher the employment incentive is, as a proportion of the labor income, the greater the benefits to the poor families are. The simulations also showed that at total population level, regardless of the envisaged scenario, the poverty rate decreases, in the presence of new employment incentives, for certain categories of households, especially for those who have one or more children in care, the poverty reduction is much more significant. This is a positive fact, especially as poverty among children and families with children is higher, as is shown by Eurostat data. It is obvious that, at a higher and more attractive employment incentive, the poverty rate decreases more significantly. The model is, indeed, a rather restrictive one, only aiming at the evolution of the poverty incidence and not at other important coordinates such as the budget effort involved or the targeted quotas, as the number of potential beneficiaries or even the number of those who could become employed on the incentives provided by raising with a certain proportion the labor income for the beneficiaries of guaranteed minimum income. Also, the behavioral changes that could be induced by these employment incentives, such as increasing the motivation to work among these beneficiaries, could not be modeled. Besides pointing out the poverty reduction among these beneficiaries of guaranteed minimum income, it would be also important to know the following: the budgetary effort involved in both scenarios; the targeted quotas that would be stimulated to become employed, respectively, how much these activation incentives would influence those earning income households, some even from employment, which might be eligible for social benefits under the new conditions of inserting these activation elements into the guaranteed minimum income, and those contingents that would be encouraged to become employed in these new incentive conditions. These analyzes can be particularly important even in terms of efficiency and effectiveness, as well as the balance between the budgetary effort involved and the positive effects observed from the point of poverty reduction and stimulating the employment of the beneficiaries. Those aspects would complete the picture of the efficiency of reforming the guaranteed minimum income scheme. The introduction of activation incentives in the guaranteed minimum income schemes may, under certain conditions, induce traps, "poverty trap" or "low wage trap", as they are known in literature, in the sense that in certain situations regarding the disposable income of household members, it may be possible that the support provided through the social assistance benefits system to be influenced by the income obtained from employment. More in-depth analyzes of "poverty trap" are needed in households, because of those situations where social assistance beneficiaries are not tempted to look for employment, with the motivation that because of their work income, the family would no longer be eligible for that or those social assistance benefits. It is possible that a person does not renounce to the resources from social transfers, because the person does not want to assume high costs, much higher than the benefits that these social benefits give him/her. Balancing these two aspects could discourage a person from looking for a job and make the person prefer to remain in the social welfare network. With regard to these traps, such as the "poverty trap", some authors, who focused on the analysis of poverty indicators in 2010, mentioned that at national level the tax rate on low earnings - low wage tramp, at 33 % of AW, was about 31% for a single person without children and slightly higher for one-earner married couple with two children, according to Lincaru and Ciuca (2014); while in 2015 - the last available year according to Eurostat, Databases and indicators, Tax and benefits databases- these rates are somewhat higher. These poverty traps are found commonly among people with low incomes, Eurostat noting that "This kind of trap is most likely to occur at relatively low wage levels due to the fact that the withdrawal of social transfers (mainly social assistance, in-work benefits and

housing benefits), which are usually available only to persons with a low income, adds to the marginal rate of income taxes and social security contributions". Other authors, like Colombino (2015), appreciated that "Until the late 1990s and early 2000s, the social assistance policies of most industrialized countries were close to a (more or less generous) means-tested guaranteed minimum income, with a high implicit benefit reduction rate (the rate at which benefits are withdrawn as the recipient's own earnings increase)". Colombino (2015), also says: "Such mechanisms are known to weaken the incentives to work (a "poverty trap" effect, which prevents people from escaping poverty), arguing that, given a total reduction of the benefit, putting aside non-pecuniary motivations, there is no point in working for earnings below  $G$  (a certain level of the net income), and there might be no point in working at all without the opportunity and the willingness to earn sufficiently more than  $G$ ". Thus, in the case of a guaranteed minimum income, with a benefit reduction rate of less than 100%, Colombino (2015) considers that "such policies are useful for managing short-term income support programs and moderating poverty trap effects, they do not meet the goal of an efficient mechanism of global redistribution". Even in such situations, the author believes that "Incentive-augmented conditional minimum income policies do not eliminate the poverty trap, but also other hidden effects". Other authors, such as Bargain and Orsini (2006), appreciate that "Generous social assistance has been held responsible for inactivity traps and social exclusion in several European countries, hence the recent trend of promoting employment through in-work transfers. Yet, the relative consensus on the need for "making work pay" policies is muddled by a number of concerns relative to the design of the reforms and the treatment of the family dimension. In-work policies in Europe: Killing two birds with one stone?" These topics should be analyzed in-depth in order to make sure that all results estimated by the insertion of these activation components in the guaranteed minimum income, such as the reduction of relative poverty or the stimulation of employment of beneficiaries (and so on) form a series of improvements of the program regarding this important social assistance benefit.

## 5. CONCLUSIONS

The paper aimed to introduce activation elements in the guaranteed minimum income, that would stimulate work and at the same time reduce poverty. This was achieved by conducting two simulations at two different thresholds, through certain proportions applied to the work income considered when establishing the new family income subject to eligibility for the guaranteed minimum income scheme. The simulations proposed two values, those of 35% and 65% of the labor income, that will not be considered in the calculation of the tested income for social benefits such as the guaranteed minimum income. The scenario with the 50% threshold applied to the work income within the guaranteed minimum income has been simulated and the results have been published and are about to appear (Stroe, and Cojanu 2018). For each of these two variants we obtained a different emphasis on the guaranteed minimum income in terms of obtained performance in reducing poverty by highlighting the relative change in the rate of relative poverty, determined at the threshold of 60% of the median income, even if the simulation model could not capture more aspects, but only the evolution of poverty when considering each of the two scenarios. Our hypotheses were focused on the income of those households with employed people, households eligible for the guaranteed minimum income, when certain proportions of labor income are no longer considered in determining the income for obtaining the social assistance, as well as on households with one or more children in care, starting from the premise that these households with children are facing high poverty rates. These simulations could provide some benchmarks for policy makers, when dealing with both budgetary constraints and poverty reduction targets (interdependent conditions), but also improve this important benefit, part of the social assistance benefits system. Regardless of the scenario envisaged, even in the case of the pessimistic one, it is highlighted that poverty is



reduced by a certain percentage when an activation component is considered, which should be more stimulating than today. Thus, in both scenarios, simulated poverty rates in both the total population and many types of households, especially those with one or more dependent children and experiencing high incidence of poverty, have a visible and significant tendency of reduction in the presence of these employment incentives. At the same time, simulated rates have highlighted that poverty reduction is greater as a higher percentage of labor income is not considered when testing eligibility for guaranteed minimum income. Moreover, it is noticed that as the proportion of the labor income that is not considered when establishing the eligibility for granting guaranteed minimum income is higher, the size of the effect on relative poverty rate and the relative change of poverty increases as well. Thus, if the income test does not consider the percentage of 35% of labor income in households with an employed person, then the relative poverty rate would slightly decrease, while when increasing that proportion, the reduction in poverty is more significant. It can be concluded that the employment incentives taken into account in the two scenarios applied to the labor income for those households with employed persons and that call for the guaranteed minimum income, regardless of the 35% or the 65% thresholds of the labor income, are all the more stimulating as the proportion is higher and they lead to a lower incidence of poverty. So regardless of the scenario, the incidence of poverty is reduced in comparison to the present, when 15% is added to social assistance for those beneficiaries who are employed and receive a salary income. Even more important is that, regardless of the scenario envisaged in the total population, the simulations showed that the poverty rate in the presence of new employment incentives is reduced for certain categories of households, especially those who have one or more children in care, where the effects are more emphasized in reducing poverty, the amount being much more significant. As a result of the simulation exercises, was noted: the higher the proportion of the work income included in the new income threshold, the greater the efficiency in reducing the poverty among the households is. This is a positive fact, especially since poverty among children and families with children increases with each day and there is little time until the Europe 2020 Strategy should complete its strategic goals. Also, the national strategies have the same deadline and the same major goals to reduce poverty and its severe and extreme forms, not only for these categories, but also for all disadvantaged population groups, for increasing their social and occupational inclusion, and for raising their living standards and the quality of life, as a whole.

**ACKNOWLEDGEMENT:** *"The integrated system for poverty and social exclusion alleviation in rural areas Project was contracted and financed from the state budget, through the Ministry of Labor and Social Justice. The project is part of the sectoral research and development Plan of the Ministry of Labor and Social Justice for the period 2018-2020. The project was implemented by the consortium formed by the National Scientific Research Institute for Labor and Social Protection, as coordinator, and partners "Alexandru Ioan Cuza" University of Iasi, respectively the Center for Urban and Regional Sociology, CURS SRL in the period 2018-2019".*

#### **LITERATURE:**

1. Marshal, T.H. (1950). *Citizenship and social class*. Cambridge: At the University Press. 23/47. Retrieved 05.09.2018 from [http://www.jura.uni-bielefeld.de/lehrstuehle/davy/wustldata/1950\\_Marshall\\_Citizenship\\_and\\_Social\\_Class\\_OCR.pdf](http://www.jura.uni-bielefeld.de/lehrstuehle/davy/wustldata/1950_Marshall_Citizenship_and_Social_Class_OCR.pdf).
2. Rawls, J. *A theory of Justice*. Cambridge: The Belknap Press of Harvard University Press. 243/562. Retrieved 05.09.2018 from [http://www.consiglio.regione.campania.it/cms/CM\\_PORTALE\\_CRC/servlet/Docs?dir=docs\\_biblio&file=BiblioContenuto\\_3641.pdf](http://www.consiglio.regione.campania.it/cms/CM_PORTALE_CRC/servlet/Docs?dir=docs_biblio&file=BiblioContenuto_3641.pdf).

3. Gurgand, M., Margolis, N. (2005). Does Work Pay in France? Monetary Incentives and the Guaranteed Minimum Income. *IZA Discussion Paper No. 1467/2005*. Retrieved 07.09.2018 from [https://papers.ssrn.com/sol3/papers.cfm?abstract\\_id=651982](https://papers.ssrn.com/sol3/papers.cfm?abstract_id=651982).
4. Figari, F., Matsaganis, M., Sutherland, H. (2013). Are European social safety nets tight enough? Coverage and adequacy of Minimum Income schemes in 14 EU countries. *International Journal of Social Welfare*. Volume 22, Issue 1. Retrieved 07.09.2018 from <http://onlinelibrary.wiley.com/doi/10.1111/j.1468-2397.2012.00885.x/full>.
5. International Labour Office, Social Protection in Action. Building Social Protection Floors, November 2015. Country Note Series 2015. Retrieved 10.09.2018 from <http://www.social-protection.org/gimi/gess/RessourcePDF.action?ressource.ressourceId=53361>.
6. Ministry of Community and Social Services, Ontario, Canada. Ontario's Basic Income Pilot. Studying the impact of basic income. 2017-2018. Retrieved 10.09.2018 from [https://files.ontario.ca/170508\\_bi\\_brochure\\_eng\\_pg\\_by\\_pg\\_proof.pdf](https://files.ontario.ca/170508_bi_brochure_eng_pg_by_pg_proof.pdf) and <https://www.ontario.ca/page/ontario-basic-income-pilot>.
7. BIEN / Basic Income Earth Network. Kate McFarland. 2017. Overview of Current Basic Income Related Experiments (October 2017). Retrieved 10.09.2018 from <http://basicincome.org/news/2017/10/overview-of-current-basic-income-related-experiments-october-2017/>, and <http://www.resilience.org/stories/2017-11-02/overview-of-current-basic-income-related-experiments-october-2017/>.
8. Legros, M. (2009). France – Minimum Income Schemes. From crisis to another, The French experience of means-tested benefits. *Peer Review in Social Protection and Social Inclusion and Assessment in Social Inclusion*. Retrieved 10.09.2018 from
9. Lincaru, C., Ciuca, V. *Youth and the Labour Market in Romania*. Adapt Labour Studies Book-series. Cambridge Scholars Publishing. 101/415.
10. Stroe, C., Cojanu, S.F. (2018). Ex-ante assessment of the activation component insertion within the guaranteed minimum income on the incidence of poverty in Romania. *Rethinking Social Action. Core Values in Practice. RSACVP 2018*.
11. EUROSTAT. Retrieved 17.09.2018 from <http://ec.europa.eu/eurostat/web/income-and-living-conditions/data/database>.
12. Eurostat. Database and indicators – Tax and benefits database. Retrieved 17.09.2018 from <http://ec.europa.eu/social/main.jsp?catId=1143&intPageId=3197&langId=en>.
13. Eurostat. Database. Retrieved 17.09.2018 from [http://appsso.eurostat.ec.europa.eu/nui/show.do?dataset=earn\\_nt\\_lowwtrp&lang=en](http://appsso.eurostat.ec.europa.eu/nui/show.do?dataset=earn_nt_lowwtrp&lang=en).
14. Colombino, U. (2015). Is unconditional basic income a viable alternative to other social welfare measures?. *IZA World of Labor, Evidence-based policy making*. Retrieved 26.09.2018 from <https://wol.iza.org/uploads/articles/128/pdfs/is-unconditional-basic-income-viable-alternative-to-other-social-welfare-measures.pdf?v=1>.
15. Bargain, O., Orsini, K. (2006). In-work policies in Europe: Killing two birds with one stone? *Labour Economics*. Volume 13, issue 6, 667-697. Retrieved 26.09.2018 from <https://www.sciencedirect.com/science/article/pii/S0927537105000783>.

## AUDIT OF PUBLIC PROCUREMENT EFFORTS AND REVIEW OF RECOMMENDATIONS

**Dubravka Mahacek**

*State Audit Office, Regional Office Požega  
Faculty of Medicine in Osijek  
dmahacek@vup.hr*

**Aleksandar Vcev**

*Faculty of Dental Medicine and Health in Osijek  
aleksandar.vcev@fdmz.hr*

**Damir Sebo**

*Faculty of Dental Medicine and Health in Osijek  
damir.sebo@fdmz.hr*

### ABSTRACT

*The paper outlines the research on the implementation of the recommendations given to companies after public procurement performance audits. Performance audits were conducted by the State Audit Office, which compiled individual reports. Companies were given recommendations in order to improve their business operations. After a certain period, audits were conducted to determine whether the given recommendations had been implemented. The paper explores the possibilities of improving the efficiency of public procurement procedures in companies and the impact of such improvements on business operations. Based on the research conducted in the companies, it was established that the progress made by the companies included in this paper was satisfactory. The given and implemented recommendations were studied and analysed. Conclusions were reached regarding the impact of the implemented recommendations on the companies' business operations. Legal framework and the significance of public procurement in business operations were also researched. The paper used the data from the audits performed by the State Audit Office, as well as from other reference materials. The research described in the paper pertains to seven companies in which a public procurement performance audit was conducted. Public procurement performance audits were conducted for the period from 2011 to 2013 in three companies, the period from 2013 to 2015 in another three companies and the period from 2012 to 2014 in one company. The paper also mentions other companies in which public procurement performance audits were conducted (six companies), whose public procurement procedures were also assessed in terms of efficiency. However, for them, no follow-up audit was conducted to review the implementation of the given recommendations up until the moment of writing this paper. Each performance audit was followed by a report containing an assessment of the public procurement system. Another report was also made after conducting a follow-up audit to review the implementation of the given recommendations. The paper confirmed the assumption that companies can significantly influence their financial result by implementing the recommendations given in the public procurement audits. Monitoring the implementation of the given recommendations in entities in which an audit was conducted highlights the importance and role of audit in the business process, improves transparency and public influence.*

**Keywords:** *Auditing, Business, Efficiency, Enterprises, Recommendations*

## **1. INTRODUCTION**

Public procurement holds significant importance for every business entity, be it a company, a budgetary entity or a non-profit organisation. Importance of public procurement for Croatian economy is evident from the following data: "in 2013, in the Republic of Croatia, contracting authorities and entities purchased goods, works and services with total value of HRK 39,485,757,201.00, including VAT, of which HRK 33,148,035,625.00 (including VAT) through contracts awarded in public procurement procedures (Ministry of Economy, Public Procurement, p. 7). According to the same source, the system of public procurement should ensure economical and efficient procedures, as well as rational spending of taxpayers' money. For the purpose of advancing that system, significant progress was made between 2008 and 2014, when the legal framework regulating public procurement was approximated with the European Union acquis. The objectives of public procurement include short-term or primary objectives, which are rational and efficient spending of budgetary funds, as well as long-term or secondary goals, which primarily include legal certainty, prevention of corruption and crime, positive influence on economic growth and employment (encouraging competition, promoting excellence), improving public finances management, environmental protection, etc. Significance of procurement in national economy is reflected in the fact that the European Union puts emphasis on the priorities which complement each other. Economic situation requires a more rational approach to public spending, thus making the efficiency of public procurement a priority for all the member states. The value of procurement carried out by companies is significant and affects overall business operations, which is illustrated on the examples of individual companies (Turkalj, Ž.; Mahaček, D., 2015, p. 69). Therefore, in this paper, we focus on public procurement from the aspect of conducted performance audits and the recommendations given during those audits.

## **2. LEGAL BASES FOR PUBLIC PROCUREMENT AND CONDUCTING AUDITS**

The principal legislative act regulating public procurement is the Public Procurement Act. On 1 January 2017, a new Public Procurement Act (Official Gazette 120/2016) entered into force. Companies must adopt a Procurement Plan for the purpose of planning the procurement of goods, works and services. Procurement Plan, as well as any modifications of the Plan, if any during the year, must be published on the Internet.

### **2.1. Data on conducted procurement**

Within the audit process, a statistical report on public procurement is inspected. The report indicates the amount of goods, services and works procured, and the type of public procurement procedures employed. Provisions of Article 28 of the Public Procurement Act stipulate that the contracting authority/entity shall maintain a Register of Public Procurement Contracts and Framework Agreements and update it on a regular basis. Pursuant to Article 28, paragraph 7 and Article 198, paragraph 5 of the Public Procurement Act (Official Gazette 120/16), the Ministry of Economy, Entrepreneurship and Crafts adopted an Ordinance on Procurement Plan, Contracts Register, Preliminary Consulting and Market Analysis in Public Procurement (Official Gazette 101/2017), which entered into force as at 1 January 2018. Said Ordinance stipulates the contents, adoption deadline, manner and time of publishing, as well as other matters related to the Procurement Plan and the Register of Public Procurement Contracts and Framework Agreements, as well as the contents of reports, manner and deadlines of publishing and other matters related to preliminary consulting and market analysis. As of January 2018, there have been certain changes in data entering and display in the Register of Public Procurement Contracts and Framework Agreements. The Register is filled out automatically. Public procurement contracts and framework agreements, including any contracts based on framework agreements (three-month contract publications), are automatically entered in the

Register when appropriate notices on contract award are published in the Electronic Public Procurement Classifieds of the Republic of Croatia (single portal where contracting authorities/entities publish their notices, and prospective tenderers can see all the notices). All contract award notices sent for publication after 1 January 2018 are included in the Register for 2018. The Register is updated according to the date of sending the form, not according to the date of contract conclusion. Data on contracts on simple procurement is entered in the Register manually, and the contracts on simple procurement are also added manually. Contracts may be updated and data in them may be changed. Public procurement contracts concluded based on framework agreements may be updated subsequently, by adding the data that are not contained in the form (those pertaining to performing the contract in its entirety and alike). Updating can be done the same way as with the contracts on simple procurement, but the data published in the form itself cannot be changed (contract value, selected tenderers and alike). Published contract registers may be viewed by all the users, as well as by anonymous users. They can be accessed on the home page of the Electronic Public Procurement Classifieds of the Republic of Croatia, contract registers, by selecting the period and the contracting authority/entity.

#### *2.1.1. Performance audit in general*

Mandate of the State Audit Office is prescribed by regulatory provisions (State Audit Office Act, Articles 6 and 7). Said provisions stipulate that the audit shall also include the assessment of economy and efficiency of operations, as well as the assessment of how effectively have general objectives of business or the objectives of individual financial transactions, programmes and projects been met. The Office has conducted numerous performance audits, such as those related to achievement of results and objectives of business operations in the companies owned by local and regional self-government units, related to public procurement efficiency, work of supervisory boards, preventing and detecting fraud in companies, etc. Performance audit differs from a financial audit because it does not comprise all of the company's operations, only certain programs, projects and alike.

#### *2.1.2. Public procurement performance audit*

Public procurement in state owned companies in the Republic of Croatia was assessed by the State Audit Office as a high-risk segment. In its assessment, the Office stated: "Considering said objectives of public procurement and the fact that in previous years, in auditing of financial statements and operations of state-owned companies in the Republic of Croatia irregularities as regards public procurement have been determined almost as a rule, the State Audit Office has assessed the public procurement segment in those companies as a high-risk segment." (Report on conducted performance audit, public procurement system in the state-owned companies in the Republic of Croatia, State Audit Office, Zagreb, November 2015, p. 2). Based on the conducted public procurement performance audits, possibilities to improve the efficiency of public procurement system in state-owned companies in the Republic of Croatia have been studied and analysed (Turkalj, Ž.; Mahaček, D., 2015, p. 73). Value of the conducted public procurement procedures, as well as recommendations for efficiency and prospects of their impact on improvement of business operations have all been analysed. The importance of conducting public procurement processes was confirmed, along with the significance and impact of such processes both on the economy as a whole, and also on companies, in which such processes aim to improve business operations through implementation of the recommendations related to efficiency of the public procurement system. In addition to being influenced by the public procurement system, companies' efficiency is also influenced by other factors. Improvement of business operations can also be achieved through remedying any irregularities and inadequacies identified in setting business objectives and in business results (Turkalj, Ž.; Mahaček, D., 2015, p. 522).

The research confirmed significant differences between the companies owned by the local and regional self-government units in the observed counties, in terms of their source of financing related to founders' support and in terms of their business result. Therefore, company efficiency may be improved through conducting audits of certain company segments that affect the company as a whole. Public procurement procedures and their implementation are extremely important for a company, which is why this paper pays the subject special attention.

### **3. PERFORMANCE AUDITS CONDUCTED**

Objectives of the conducted public procurement performance audits were to see if there were clear public procurement procedures established – from the planning stage to the stage of entry into service; if the procedures of public procurement of goods, works and services were carried out according to regulations; if the procured goods, works and services were of suitable quality at the most favourable prices; if the internal control system was in place for the purpose of remedying any inadequacies and irregularities in the public procurement procedures; if there was an actual need for the conducted procurement; and, finally, to see if the conducted public procurement procedures achieved the objectives which ensure improvement in quality and meeting the actual needs of end users. The State Audit Office monitors the actions undertaken by an audited entity with regard to the implementation of orders and recommendations specified in the report on the conducted audit. Auditing standards form the basis for controlling the implementation of the orders and recommendations. Principles related to the audit process are reporting and follow-up. "Follow-up SAIs have a role in monitoring action taken by the responsible party in response to the matters raised in an audit report. Follow-up focuses on whether the audited entity has adequately addressed the matters raised, including any wider implications. Insufficient or unsatisfactory action by the audited entity may call for a further report by the SAI" (INTOSAI, ISSAI 100, p. 16). Table 1 provides an overview of conducted public procurement performance audits in the companies we included in the sample in this paper, along with the overview of the periods for which the audits were conducted and the assessments of public procurement systems. As regards the thirteen companies presented, we can conclude that in eight of them the audit assessed the public procurement system as being insufficiently efficient; in three as efficient but needing certain improvements; and in two as efficient.

*Table following on the next page*

*Table 1: Conducted public procurement performance audits (source: Report on conducted audits of implementation of the recommendations given in companies' performance audits, November 2017, pp. 15-20; Report on conducted audit of implementation of the recommendations given in public procurement performance audit of Odvodnja d.o.o., Zadar, March 2018. p. 2; Report on conducted audit of implementation of the recommendations given in public procurement performance audit and financial audit of Zračna luka Rijeka d.o.o., Rijeka, January 2018, p. 2; Report on conducted audit of implementation of the recommendations given in public procurement performance audit of Zračna luka Zadar d.o.o., Zadar, March 2018., p. 2; Report on conducted public procurement performance audit in state-owned companies in the Republic of Croatia, November 2017, p. 1)*

Company	Audited period	Assessment of public procurement system
Autocesta Rijeka-Zagreb d.d.	2011 - 2013	Insufficiently efficient
Hrvatska elektroprivreda d.d.	2011 - 2013	Insufficiently efficient
Hrvatske autoceste d.o.o.	2011 - 2013	Insufficiently efficient
Narodne novine d.d.	2012 - 2014	Insufficiently efficient
Odvodnja d.o.o., Zadar	2013 - 2015	Efficient but needing certain improvements
Zračna luka Rijeka d.o.o.	2013 - 2015	Efficient but needing certain improvements
Zračna luka Zadar d.o.o.	2013 - 2015	Insufficiently efficient
Hrvatske šume d.o.o.	2014 - 2016	Inefficient
Croatia Airlines d.d.	2014 - 2016	Inefficient
Jadroplov d.d.	2014 - 2016	Inefficient
Hrvatska kontrola zračne plovidbe d.o.o.	2014 - 2016	Efficient but needing certain improvements
Hrvatska lutrija d.o.o.	2014 - 2016	Efficient
Zračna luka Split d.o.o.	2014 - 2016	Efficient
Total 13	-	-

The objectives of reviewing the implementation of the given recommendations were to assess whether the given recommendations had been implemented and whether satisfactory progress had been made. Monitoring the implementation of recommendations is an integral part of the audit process. Expected outcome of implementing recommendations in the area of public procurement is a higher level of public accountability for economic and rational management of funds, as well as significant savings (Mahaček, D., Včev, A., Šebo, D., 2017, p. 154). After a certain period, follow-up audits are conducted to determine whether the given recommendations were implemented, which is important to determine whether the recommendations were adopted and what were their effects. Table 2 provides an overview of companies in which a follow-up audit was conducted to review the implementation of recommendations given during public procurement performance audits. Seven sample companies were given a total of 122 recommendations, 103 or 84.4 % of which were

implemented. At the single company level, it can be seen that the majority of recommendations was implemented. In the course of audit, most companies were assessed to have achieved satisfactory progress. However, one company implemented a satisfactory number of recommendations, but in terms of significance of the ones not implemented, which pertained to project implementation, satisfactory progress was not achieved.

*Table 2: The number of given recommendations and the number of not-enforced recommendations (source: Report on conducted audits of implementation of the recommendations given in companies' performance audits, November 2017, p. 1; Report on conducted audit of implementation of the recommendations given in public procurement performance audit of Odvodnja d.o.o., Zadar, March 2018. p. 5; Report on conducted audit of implementation of the recommendations given in public procurement performance audit and financial audit of Zračna luka Rijeka d.o.o., Rijeka, January 2018, p. 9; Report on conducted audit of implementation of the recommendations given in public procurement performance audit of Zračna luka Zadar d.o.o., Zadar, March 2018., p. 6)*

Company	Total recommendations	Recommendations made	Not-enforced recommendations	% conducted	Assessment: Satisfactory progress achieved or not achieved
Autocesta Rijeka-Zagreb d.d.	20	16	4	80.0	Achieved
Hrvatska elektroprivreda d.d.	24	20	4	83.3	Achieved
Hrvatske autoceste d.o.o.	24	22	2	91.7	Achieved
Narodne novine d.d.	20	14	6	70.0	Satisfactory number of recommendations implemented, but in terms of significance of the ones not implemented, which pertained to project implementation, satisfactory progress was not achieved
Odvodnja d.o.o., Zadar	7	7	0	100.0	Achieved
Zračna luka Rijeka d.o.o.	15	12	3	80.0	Achieved
Zračna luka Zadar d.o.o.	12	12	0	100.0	Achieved
Total 7	122	103	19	84.4	Achieved

Different auditing methods and procedures were used to collect the necessary audit evidence for conducting performance audits and follow-up audits of implementation of the given



recommendations. To collect the audit evidence for conducting performance audits, procedures applied were: inspecting regulations, professional publications and other materials; conducting interviews with managers and other company employees; inspecting and reviewing company documents; direct substantive testing; direct observations; analytical procedures and data calculation and analysis. To collect the audit evidence for follow-up audits of implementation of the given recommendations, companies were sent a request to assess their own progress in implementing each of the given recommendations. Interviews with responsible persons were conducted and company documents were inspected. During the audit procedure, actions taken to implement the recommendations were identified. Figure 1 provides an overview of implemented recommendations in relation to all the recommendations given to individual companies (in line with the data from Table 2).

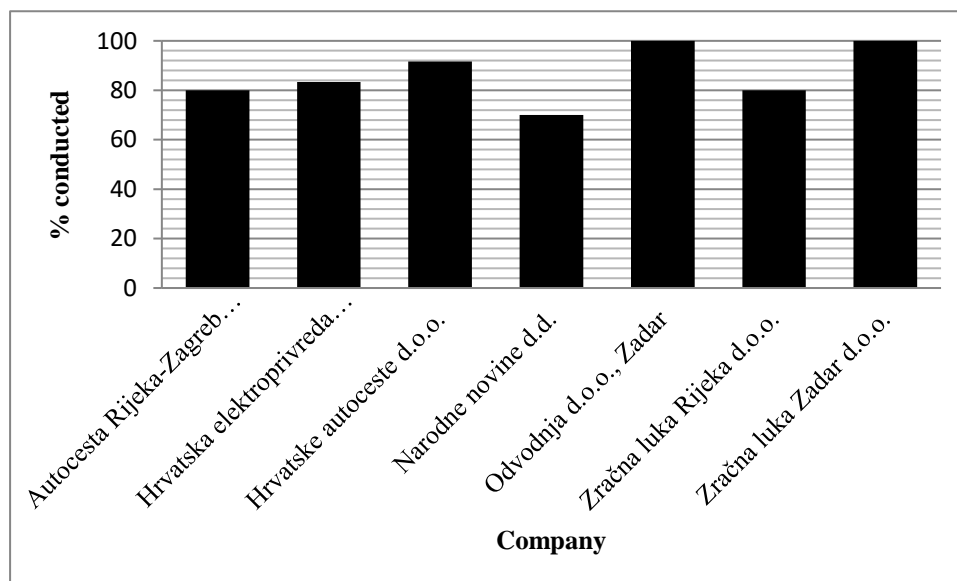

Figure 1: Implemented recommendations (in line with the data from Table 2)

Companies included in this paper were given 122 recommendations, 103 of which were implemented and 19 were not implemented (Table 2). Implementing the recommendations resulted in positive effects in said companies. The following lists represents the actions taken by the companies to improve efficiency:

- They regulated preparing of tender documents, carrying out public procurement procedures and monitoring the realization of public procurement plans by general acts
- They established procedures on optimal reserves
- They established procedures for adopting of the Procurement Plan
- They recorded projects in the Procurement Plan in accordance with project management procedures
- They conducted reviews of estimated values determined by project managers
- They visibly indicated any amendments to the Procurement Plan in relation to the initial Procurement Plan
- They set up records for monitoring of individual public procurement contracts
- They drew up tender documents clearly
- They initiated public procurement procedures in order to procure services after conducting such procedures
- They conducted negotiated procedures pursuant to the provisions of the Public Procurement Act

- They awarded contracts in accordance with terms and conditions stipulated in tender documents
- They assessed the validity of planned procurement
- They obtained complete projects before contract conclusion
- They obtained written evidence on supply market research and information on the works, goods and services intended to be procured
- They identified possible risks involved in conducting public procurement procedures, i.e. they set up a risk register, established risk avoidance measures and designated persons responsible for risk avoidance
- They contracted equal prices for equal works
- They prepared bills of quantities with prices of individual services or works being procured for the purpose of controlling and comparing contracted services or works to those actually carried out
- They determined realistic time limits in contracts
- They contracted payment in accordance with their internal acts
- They combined public procurement procedures for comparable goods instead of dividing procedures into groups
- They conducted open public procurement procedures with the aim of achieving more favourable prices
- They selected the most advantageous tenders pursuant to the provisions of the Public Procurement Act
- They stored tender documents pursuant to the provisions of the Public Procurement Act
- They concluded contracts in accordance with terms and conditions stipulated in tender documents
- They reviewed contractual terms from the technical, legal and economic aspect prior to contract conclusion
- They contracted contractual terms on liquidated damages in the event of unjustified delays
- They obtained performance guarantees
- They monitored contract performance and compiled reports thereon
- They assessed the procurement from selected suppliers with regard to their ability to deliver the goods, works and services of the contracted quality, within agreed time limits and at the contracted prices
- They concluded annexes to contracts in cases of modified volume of services provision
- They approved extension of deadlines for performance of works based on reports of the supervising engineers containing the reasons for such extensions
- They kept minutes on the takeover and final account of works, with all the elements essential for monitoring contract performance
- They made sure that issued payment certificates for performed works contained information on technical specifications of the installed equipment and specifications of performed construction works, all in accordance with tender documents and tenders of the selected tenderers
- They kept uniform records on concluded contracts for all organizational units involved in the public procurement procedure
- They established records of payment under contracts and entered prescribed information on payment of the final amount under concluded public procurement contracts in the Register of Public Procurement Contracts and Framework Agreements
- They kept a Contract Register in accordance with the provisions of the Public Procurement Act
- They entered information into the Contract Register in a timely manner

- They published notices on concluded contracts in the Electronic Public Procurement Classifieds within the time limits prescribed by the provisions of the Public Procurement Act
- They reviewed the authorizations to use company vehicles.

Some of the analysed companies implemented the listed recommendations, whereas some did not implement all of them. Therefore, the implementation of the remaining recommendations should be monitored further.

#### 4. CONCLUSION

In the conducted public procurement performance audits, it was assessed that the companies included in this paper achieved satisfactory progress. We reviewed the implemented recommendations and compared them to all the recommendation given, concluding that a significant number of the given recommendations had been implemented. Said recommendations affected the achievement of results and meeting the objectives of business operations. Continual monitoring of the implementation of recommendations influences the entities and consequently achieves the purpose of the conducted audit processes. In future research, it would be useful to determine which recommendations are not implemented after a repeated audit, as well as the reasons for failure to implement them and their impact on the company's financial results. The research confirmed the assumption that the implementation of the given recommendations has an impact on overall business operations, which is evident in meeting the business objectives, fulfilling the intended purpose of the company, and finally, achieving a better financial result.

#### LITERATURE:

1. International Organisation of Supreme Audit Institutions, ISSAI 100, p. 16 Retrieved 09.10.2018 from <http://www.issai.org/media/69909/issai-100-english.pdf>.
2. Mahaček, D., Včev, A., Šebo, D. (2017), *Implementation of audit orders and recommendations in public procurement*, The 10th Multidisciplinary Academic Conference (MAC), 26-27. May 2017., proceedings, Prague: Czech Technical University, 2017. 150-156 (ISBN: 978-80-88085-13-13) Retrieved 09.10.2018 from <https://books.google.hr/books?id=ZRwIDwAAQBAJ&pg=PR1&lpg=PR1&dq=Proceedings+of+10th+MAC+2017&source=bl&ots=EhQhss7KOI&sig=AXM9Q8gPgVh4G-RcuKPRbQHbu1s&hl=en&sa=X&ved=0ahUKEwibkMmvv6TUAhUJCywKHaeDCTgQ6AEINDAD#v=onepage&q=Proceedings%20of%2010th%20MAC%202017&f=false>
3. Ministry of Economy, *Public Procurement*, Mini Guide to the business community, Retrieved 06.10.2018 from <https://www.mingo.hr/public/documents/93-vodic-javna-nabava-lowresfinalweb.pdf>.
4. State Audit Office, Zagreb, (2015). *Izvješće o obavljenoj reviziji učinkovitosti Sustav javne nabave u trgovačkim društvima u vlasništvu Republike Hrvatske*, Republika Hrvatska, Retrieved 06.10.2018 from [http://www.revizija.hr/datastore/filestore/28/sustav\\_javne\\_nabave\\_u\\_trgovackim\\_drustvima\\_u\\_vlasnistvu\\_republike\\_hrvatske2.pdf](http://www.revizija.hr/datastore/filestore/28/sustav_javne_nabave_u_trgovackim_drustvima_u_vlasnistvu_republike_hrvatske2.pdf).
5. State Audit Office, Zagreb, (2017). *Izvješće o obavljenoj učinkovitosti javne nabave u trgovačkim društvima u vlasništvu Republike Hrvatske*, Retrieved 05.10.2018 from [http://www.revizija.hr/datastore/filestore/132/JAVNA\\_NABAVA\\_U\\_TRGOVACKIM\\_DRUSTVIMA.pdf](http://www.revizija.hr/datastore/filestore/132/JAVNA_NABAVA_U_TRGOVACKIM_DRUSTVIMA.pdf).

6. State Audit Office, Zagreb, (2017). Izvješće o obavljenim provjerama provedbe danih preporuka za revizije učinkovitosti kod trgovačkih društava, Retrieved 05.10.2018 from [http://www.revizija.hr/datastore/filestore/137/PROVJERA\\_IZVRSENJA\\_DANIH\\_PREPORUKA.pdf](http://www.revizija.hr/datastore/filestore/137/PROVJERA_IZVRSENJA_DANIH_PREPORUKA.pdf).
7. State Audit Office, Zadar, (2018). Izvješće o obavljenoj provjeri provedbe danih preporuka za reviziju učinkovitosti javne nabave u društvu Odvodnja d.o.o., Zadar, Retrieved 04.10.2018 from <http://www.revizija.hr/datastore/28/ODVODNJA-D.pdf>.
8. State Audit Office, Rijeka, (2018). Izvješće o obavljenoj provjeri provedbe danih preporuka za reviziju učinkovitosti javne nabave i financijsku reviziju u društvu Zračna luka Rijeka d.o.o., Retrieved 04.10.2018 from <http://www.revizija.hr/datastore/filestore/28/ZRACNA-LUKA-RIJEKA-D.pdf>.
9. State Audit Office, Zadar, (2018). Izvješće o obavljenoj provjeri provedbe danih preporuka za reviziju učinkovitosti javne nabave u društvu zračna luka Zadar d.o.o., Retrieved 05.10.2018 from <http://www.revizija.hr/datastore/filestore/28/ZRACNA-LUKA-ZADAR-D.pdf>.
10. State Audit Office Act, Official Gazette 80/11
11. Turkalj, Ž. & Mahaček, D. (2015) Procurement procedures in the function of improving company business conduct, Business Logistics in Modern Management 2015, Proceedings of the 15th International Scientific Conference Business Logistics in Modern Management; University of Osijek - Faculty of Economics in Osijek, 15 October 2015; pp. 67 – 78, UDK: 65.012.34; ISSN 1849-5931 (Print version); ISSN 1849-6148 (Online) Retrieved 08.10.2018 from <http://blmm-conference.com/wp-content/uploads/Proceedings-of-Business-Logistics-in-Modern-Management-2015.pdf>
12. Turkalj, Ž. & Mahaček, D. (2015). Efficiency of Companies Owned by Local and Regional Self-Government Units, Interdisciplinary Management Research XI, published proceedings, Faculty of Economics in Osijek, Osijek, Postgraduate Studies, 15-17 May 2015, ISSN 1847-0408, pp. 509-523, Retrieved 07.10.2018 from <https://www.scribd.com/document/336536092/Interdisciplinary-Management-Research-IMR-XI>.

## CHATBOT EVALUATION METRICS: REVIEW PAPER

**Dijana Peras**

*Faculty of Organization and Informatics  
Pavlinka 2, HR 42000 Varaždin, Hrvatska  
dijana.peras@foi.hr*

### **ABSTRACT**

*The past few years popularity of chatbots is constantly growing, and companies have been focused on developing them more than ever. Therefore, it is not surprising to see the news about various aspects of chatbot, from design and development to commercialization and marketing, are being daily published. Nevertheless, the topic of the chatbot evaluation is very often neglected. The metrics that should be used to evaluate the success of a chatbot are not systematized nor unified. One way to solve this problem is to align the metrics to the different perspectives of the chatbot evaluation: user experience perspective, information retrieval perspective, linguistic perspective, technology perspective and business perspective. In order to build the evaluation framework, the following categories of chatbot should be analyzed: usability, performance, affect, satisfaction, accuracy, accessibility, efficiency, quality, quantity, relation, manner, grammatical accuracy, humanity and business value. This paper provides a review on the evaluation metrics available for measuring success of efforts invested in chatbot, and proposes the chatbot evaluation framework based on five perspectives. The contribution of this paper is to help researchers to identify opportunities for the future research in evaluation of chatbot performance.*

**Keywords:** chatbot, chatbot assessment, chatbot performance, evaluation metrics

### **1. INTRODUCTION**

“Chatbots are one specific type of conversational interface with no explicit goal other than engaging the other party in an interesting or enjoyable conversation.” (Venkatesh et al., 2018) Chatbots can be used in numerous areas and for various purposes - from customer service to education and entertainment, and from personal to professional purposes. They are usually embedded in chatting applications or webpages, thus enabling simple completion of tasks through conversation with user. Some of the most famous chatbots are Watson, Siri and Messenger. Chatbots have recently become the focus of academic and industrial research due to several reasons, including the rise of digital assistants and socialbots, but also advances in artificial intelligence, machine learning and related technologies. According to a recent research (Radziwill & Benton, 2017), during the last 10 years chatbots were involved in more than a third of online conversations. Evaluation of chatbots is a challenging research problem that lacks a unique and widely accepted metric, and has remained largely unsolved. Many of the existing studies about chatbots are based on the technical perspective, such as how to improve the chatbot to pass the Turing test, but there is a lack of research from other perspectives, such as the human or business point of view. (Io & Lee, 2017) Furthermore, there are too few research papers exploring the motivators for using chatbots. On the one hand, there is a lot of research about design and development of chatbots, but on the other hand, there is a serious lack of research on users motivation (Brandtzaeg & Følstad, 2017). Previous work on evaluating goal oriented dialogue systems includes TRAINS system, PARADISE, SASSI and MIMIC, which involve subjective measures and require a human assistance (Venkatesh et al., 2018). Among them, the most widely used frameworks for chatbot evaluation is surely PARAdigm for DIalogue System Evaluation (PARADISE). PARADISE estimates subjective factors by collecting user ratings through the questionnaires. Some of the subjective factors are ease of use, clarity, naturalness, friendliness, robustness and willingness to use the system again.

Apart from the subjective approach, the method uses objective approach to assess some aspects of the system, such as its effectiveness (Cahn, 2017).

## **2. REVIEW OF RESULTS OF PREVIOUS RESEARCH**

Academic and industrial research papers were examined in order to provide extensive review of existing chatbots evaluation metrics. Systematic search of Scopus, Web of Science and Science Direct platforms was made in order to identify relevant research papers. The used keywords were: chatbot, chatbot assessment, evaluation metrics, conversational agents, quality, and their combinations. Search was limited to the domains of computer science, telecommunications, education and engineering, which are also the domains with the largest number of published papers. Papers that will be further analyzed were selected if they contained at least one of the listed keywords in its title or abstract, and if they wrote about some aspect of the quality of chatbots. The refinement resulted with 15 papers that were marked as relevant, and their results will be briefly described below. It is important to notice that the previous research on evaluating chatbots is a mix of a mostly qualitative metrics and a few quantitative metrics. Subjective metrics have mainly involved a questionnaire where users have assessed their satisfaction with tested metrics, ranging from "very unsatisfied" to "very satisfied". Lack of quantitative metrics is the major shortage of most evaluation metrics. This chapter provides a review on the evaluation metrics for measuring success of chatbot extracted from the previous research on this topic. Hung et al. (Hung, Elvir, Gonzalez, & DeMara, 2009) presented an evaluation methodology that originated from the popular PARADISE methodology. Their aim was to determine the effectiveness and naturalness of the prototypical framework LifeLike. Dialog performance was described as a function of efficiency cost and quality cost. Efficiency cost measures the consumption of resources (quantitative metrics), while qualitative cost is related to the content of conversation (qualitative metrics). Kuligowska proposed various evaluation metrics for commercial chatbots. The following aspects of functioning of chatbots were analyzed (Kuligowska, 2015): visual appearance, implementation form, speech synthesis unit, knowledge base, additional functionalities, conversational abilities, context sensitiveness, chatbot personality, personalization options, responses in unexpected situations, possibility for users to rate the chatbot and website. To evaluate stated aspects, standard rating scale was used. The research was limited solely to the quality attributes of chatbots used in the business sector and it was subjective in nature. In order to increase the objectivity of the evaluation, Venkatesh et al. (Venkatesh et al., 2018) suggested the strategy of using the metrics which correspond well to human judgement. Authors provided a mechanism to unify and obtain the metrics. A framework based on user engagement, coverage of topics, consistency, variety of content and depth of the conversation was proposed. The idea was to introduce the metrics that can be calculated with aim to objectively assess chatbots, and to unify them to be able to compare chatbot performance. Chatbot users were asked to give the feedback, which was used as a baseline to evaluate the metrics. The evaluation metric was unified in order to be able to compare conversational performance in totality. A firm connection between the proposed metrics and user ratings was found, thus confirming the validity of suggested approach. With this paper, a step towards the automation of the evaluation of chatbots was made. Chakrabarti and Luger (Chakrabarti & Luger, 2012) have developed framework for evaluating chatbot conversation that was based on ideas of conversation semantics and content representation. The evaluation metric was proposed according to the Grice's maxims. Grice suggested four conversational maxims originating from the natural language: quality, quantity, relation and manner. The research was subjective by nature and it required the engagement of experts. Conversations have met the quality maxim in case the responses were factually correct, the quantity maxim in case the information was adequate, the relation maxim in case the responses were related with the context of the conversation, and the manner maxim in case the responses

were unambiguous. The potential of using Grice's Maxims to evaluate the chatbot conversation has been further explored by Jwalapuram (Jwalapuram, 2017). The author used the chatbot conversations to test the correlation of human judgements with Grice maxims. Chatbot users were asked to rate the performance of the chatbot for Grice maxims on a Likert scale. The questions were helpful in identifying the relevance of provided responses. Another qualitative approach was presented by Shawar and Atwell (Shawar & Atwell, 2007), whose evaluation metrics consisted of the efficiency of the conversation, the quality of the conversation and the satisfaction of users. The efficiency of the conversation was measured by the level of match between the user input and the chatbot response. Based on the quality of the conversation, responses were categorized into three categories: meaningful, strange or meaningless. The satisfaction of users was measured by collecting their feedback. According to Cahn (Cahn, 2017), the evaluation of chatbot performance can be made from the different perspectives. From an information retrieval perspective, the effectiveness of a chatbot should be evaluated by measuring the accuracy, precision and recall of the responses. From a user experience perspective, chatbot should maximize the user satisfaction. Users should be surveyed in order to rank bots based on usability and satisfaction. From a linguistic perspective, chatbots should be evaluated by the ability to generate full, grammatically correct and meaningful sentences. From an artificial intelligence perspective, the bot that appears most convincingly human is the most effective. An approach that can be used to assess the quality of two different chatbots was suggested by Radziwill and Benton (Radziwill & Benton, 2017). The proposed method is based on the Analytic Hierarchy Process (AHP). The methodology for the literature review related to the quality attributes and quality assessment approaches was drafted. Extracted quality attributes were grouped by effectiveness, efficiency and satisfaction. The list of quality attributes of six categories (performance, functionality, humanity, affect, ethics/behavior and accessibility) was proposed. Authors have combined different metrics, and the result was a mixed evaluation methodology that uses the AHP to assess the performance of different chatbots. The metrics proposed by Schumaker et al. (Schumaker, Ginsburg, Chen, & Liu, 2007) were evaluating the user input and chatbot responses based on the correction rate (share of the responses that had to be corrected by the user) and response satisfaction (share of the responses that were considered to be appropriate in relation to the context of the user input). Correction rate was measured quantitatively, by dividing the number of responses that were corrected by the user with the total number of responses. Response satisfaction was measured qualitatively, by using a seven point Likert scale. Apart from the presentation of listed evaluation metrics, the evaluation of three different experimental systems was conducted. First system was a pure dialog system, second was a domain knowledge system, and third was a hybrid system. Semeraro et al. (Semeraro, Andersen, Andersen, Lops, & Abbattista, 2003) proposed the evaluation approach which was based on quantitative measures related to analysis of the conversation log, qualitative measures based on questionnaires, and eye-tracking specifying the time the user spent looking at the agent, the answers or the website. The satisfaction of users was evaluated by collecting their feedback through the questionnaires. Apart from evaluating their satisfaction with the system, the authors were collecting the impressions related to the performance of the chatbot, such as effectiveness, ability to learn and help, and ease of use. Those impression were evaluated on the rating scale, ranging from 'very unsatisfied' to 'very satisfied'. Pereira and Díaz (Pereira & Díaz, 2018) introduced the attributes for evaluating the quality of chatbots that are easy to be automated (through scripting) and replicated: a) integration of a minimum set of commands, b) predicted language variations of user input and chatbot response, c) provision of the human assistance and d) efficiency. Attributes were measured as follows: a) checking for the existence of Help and Cancel commands, b) trying out typing errors and synonyms and comparing their outcome, c) checking for keywords (e.g. "redirect", "contact", "human", "help"), and d) measuring the answer time for the "Help"

command and obtaining mean values. The results of the research are indicating that chatbot programming is still underdeveloped. Coniam (Coniam, 2015) explored the quality of chatbots from the linguistic perspective. The approach was essentially qualitative. Initial set of 163 questions, commands and interruptions was utilized in order to assess the grammatical accuracy of chatbots' answers. Evaluators were counting the total number of errors made in the four-hour chat period. Word-level analyses consisted of vocabulary range, spelling, and upper/lower case. Grammar-level analyses consisted of: nouns and countability, pronouns, verbs, articles, question words, word order in questions, and word order in statements. Each response to the 163 input questions/commands/interjections was scored 1 or 0 for acceptability from grammatical, meaning, and both grammatical and meaning perspectives. A lack of research on people's motivations for using chatbots was noticed. One of the few studies dealing with this topic was conducted by Brandtzaeg and Følstad (Brandtzaeg & Følstad, 2017), who described five categories of motivation of chatbot users. Those categories were: productivity (chatbot was used to get information or help), entertainment (chatbot was used to spend free time), social/relational (chatbot was used to make interactions with other people), novelty/curiosity (chatbot was used just to explore the capabilities) and other motivations (all other motivators that do not fit in listed categories). The results of the research stated the productivity of chatbots as the key motivator for using them. Furthermore, users were expecting from the chatbot to be entertaining and social. Many of them were interested for using them in order to get new experiences or to learning new things. Authors concluded that chatbots should be developed with aim to provide necessary information in a beneficial and operative way. Zamora (Zamora, 2017) has explored the perception of users and their expectations from chatbots. Participants of the research were asked to share their impressions, experience, ways of use and routines. During the study, participants interacted with assigned chatbot. Responses were structured as a 5-point Likert satisfaction scale. The survey consisted of multiple choice and free structure responses, while the analysis of the survey consisted of open coding, scale ratings and remote task-based evaluation. Study revealed that sensitive areas (e.g. financing, private content available on social media) should not be a part of the chatbot. Furthermore, limited vocabulary hinders communication with chatbots. It is interesting that several participants expressed privacy concerns around sensitive or high-risk content due to concerns around mishandling data, while on the other hand they expressed interest in fulfilling emotional needs while talking to chatbot. Various approaches were used to evaluate the success of a chatbot, but none of the papers covers all chatbot attributes. Most authors have focused on one perspective, thus neglecting other chatbot categories. Furthermore, none of the papers provides unique chatbot evaluation framework. In the following chapter, chatbot evaluation framework that covers chatbot attributes extracted from the previous research is presented.

### **3. CHATBOT EVALUATION FRAMEWORK**

The chatbot attributes that were found in selected papers were grouped into the 14 categories, which were further grouped into the five perspectives, similar to the approach proposed in (Russell-Rose, 2017). While Russel-Rose was writing about four perspectives, this paper introduces one additional perspective, thus covering the business values that were not encompassed within other four perspectives. The perspectives are: a) the user experience perspective, b) information retrieval perspective, c) linguistic perspective, d) technology perspective and e) business perspective. Based on them, an evaluation framework was created. Proposed chatbot evaluation framework consists of: a) categories, b) attributes, c) metrics and d) approaches, and it is shown in Table1. The proposed perspectives will be described in the following subchapters.



### **3.1. User experience perspective**

User experience perspective consists of four categories: a) usability, b) performance, c) affect and d) satisfaction. Chatbot usability refers to efficiency and effectiveness, and is related to the ease of using and the time needed to complete the task. Assigned metrics are used to evaluate the level of the tasks completion and the amount of effort required from users to complete the tasks. Usability metrics are mostly qualitative by nature, since they rely on the user personality, experience and ideas. Performance refers to completion of a task in terms of completeness, promptness and appropriateness. Performance is affected by users and their goals, so the assigned evaluation metrics are qualitative by nature. The category of affect is used to evaluate the experience and emotions of chatbot users. Those attributes are hard to express numerically, and they are usually measured by surveys or questionnaires. By introducing the General Data Protection Regulation (GDPR), the privacy issues are getting more attention than ever. The more trust the user has in a chatbot, the more personal data he may start to reveal, and the more intimate conversations he may seek. Although the GDPR greatly affects the collection, use and transfer of personal data, there is a serious lack of research concerning the influence on chatbots and their users. Satisfaction refers to user's pleasure arising from the comparison of their expectations and chatbot performance. Again, those feelings are hard to express numerically. The metrics are mostly quantitative, although some of the papers are indicating the relation of satisfaction with the duration and frequency of chat.

### **3.2. Information retrieval perspective**

Information retrieval perspective evaluates how well the company meets the information needs of the users. Information retrieval perspective consists of three categories: a) accuracy, b) accessibility and c) efficiency. This perspective relates to the activities of obtaining relevant and appropriate information from a chatbot knowledge base. The assigned metrics are quantitative in nature, and they are evaluating the level of accurateness in relation with the given task, the ability to provide appropriate information and the ability to accomplish the task without spending excessive resources.

### **3.3. Linguistic perspective**

Linguistic perspective analyzes the level of the linguistic accuracy of chatbots and ability to return appropriate response. The performance at word and grammar level is being examined. Linguistic perspective consists of five categories: a) quality, b) quantity, c) relation, d) manner and e) grammatical accuracy. Four of the assigned categories can be evaluated by using Likert scale, thus measuring the level to which Grice's maxims (quality, quantity, relation and manner) are supported. Fifth metric evaluates the acceptability of chatbot from grammatical and meaning perspective. Assigned metrics are qualitative by nature and a team of experts is needed in order to carry out the evaluation.

### **3.4. Technology perspective**

Technology perspective consists of just one category: humanity. Humanity refers to the ability of chatbot to express human like behavior. To be able to do so, chatbot needs to be able not only to process natural language, but also to understand it and generate it itself. Humanity can be measured qualitatively and quantitatively. The most commonly used metric for measuring humanity is Turing test, although its application in intelligence measurement and AI field was not explicitly stated. Rating scale can also be used to test humanity of chatbot. Although such results would be subjective, they could provide a feedback for chatbot advancement.

### 3.5. Business perspective

Companies expect from chatbots to deliver business value. Business value is the difference between the effectiveness and the costs of the chatbot. Some of the proposed metrics for measuring the effectiveness of the chatbot are: a) number of users, b) duration of the chatbot conversation and c) number of the chatbot conversations. On the other hand, the costs of the chatbot can be measured by: a) number of the agents included in conversation, b) duration of the conversation with agent, c) number of the unsuccessful conversations and d) number of the unsuitable responses, and e) number of repeated queries. The assigned metrics are quantitative in nature. Chatbots are considered to be a ‘must have’ tool for basic, repetitive tasks which are easy to use and cheap to implement and maintain. For instance, they can be used to automate business processes (e.g. frequently asked questions), thus saving the valuable companies resources.

*Table 1: The Chatbot Evaluation Framework*

Perspective	Category	Attributes	Metrics	Approach
User experience perspective	Usability	<ul style="list-style-type: none"> <li>• task completion</li> <li>• getting assistance or information</li> <li>• support of a minimal set of commands</li> <li>• response type frequency</li> </ul>	<ul style="list-style-type: none"> <li>• response type relative frequencies</li> <li>• percentage of match</li> <li>• response type relative probability</li> <li>• rating scale</li> <li>• surveys</li> <li>• questionnaires</li> <li>• support of Help and Cancel commands</li> </ul>	Qualitative, Quantitative
	Performance	<ul style="list-style-type: none"> <li>• robustness</li> <li>• responses in unexpected situations</li> <li>• coherence</li> <li>• effective task allocation</li> </ul>	<ul style="list-style-type: none"> <li>• percentage of success</li> <li>• rating scale</li> </ul>	Qualitative
	Affect	<ul style="list-style-type: none"> <li>• personality</li> <li>• emotional information</li> <li>• entertainment</li> <li>• engagement</li> <li>• personality traits</li> <li>• human assistance provision</li> <li>• trustworthiness</li> <li>• privacy protection</li> </ul>	<ul style="list-style-type: none"> <li>• rating scale</li> <li>• surveys</li> <li>• questionnaires</li> <li>• checking for keywords</li> <li>• number of dialogue turns</li> <li>• total conversation duration</li> </ul>	Qualitative, Quantitative
	Satisfaction	<ul style="list-style-type: none"> <li>• expectation</li> <li>• impression</li> <li>• command</li> <li>• navigability</li> <li>• engagement</li> <li>• entertainment</li> <li>• curiosity</li> <li>• social relations</li> <li>• ability to learn</li> <li>• ability to aid</li> </ul>	<ul style="list-style-type: none"> <li>• conversation duration</li> <li>• number of conversation turns</li> <li>• rating scale</li> </ul>	Qualitative, Quantitative

Information retrieval perspective	Accuracy	<ul style="list-style-type: none"> <li>• ability to foresee language variations</li> </ul>	<ul style="list-style-type: none"> <li>• precision</li> <li>• recall</li> <li>• typing errors and synonyms</li> </ul>	Quantitative
	Accessibility	<ul style="list-style-type: none"> <li>• ability to detect meaning and intent and to respond appropriately</li> </ul>	<ul style="list-style-type: none"> <li>• context sensitiveness</li> <li>• percentage of success</li> <li>• number of inappropriate responses</li> <li>• turn correction ratio</li> </ul>	Quantitative
	Efficiency	<ul style="list-style-type: none"> <li>• how well the resources are applied to achieve the goals</li> </ul>	<ul style="list-style-type: none"> <li>• matching types</li> <li>• measuring the answer time for the commands and obtaining mean values</li> <li>• total elapsed time</li> <li>• total number of users turns</li> <li>• total number of turns per task</li> </ul>	Quantitative
Linguistic perspective	Quality	<ul style="list-style-type: none"> <li>• correctness of the responses</li> <li>• categorization of responses</li> </ul>	<ul style="list-style-type: none"> <li>• Likert scale</li> </ul>	Qualitative
	Quantity	<ul style="list-style-type: none"> <li>• adequateness of information</li> </ul>	<ul style="list-style-type: none"> <li>• Likert scale</li> </ul>	Qualitative
	Relation	<ul style="list-style-type: none"> <li>• relevancy of responses to the context of the conversation</li> </ul>	<ul style="list-style-type: none"> <li>• Likert scale</li> </ul>	Qualitative
	Manner	<ul style="list-style-type: none"> <li>• unambiguity of the responses</li> </ul>	<ul style="list-style-type: none"> <li>• Likert scale</li> </ul>	Qualitative
	Grammatical accuracy	<ul style="list-style-type: none"> <li>• acceptability from grammatical and meaning perspective</li> </ul>	<ul style="list-style-type: none"> <li>• total number of errors made in the chat period</li> <li>• Word-level analysis (vocabulary range, spelling, upper/lower case)</li> <li>• Grammar-level analysis (nouns, pronouns, verbs, word order, etc.)</li> </ul>	Qualitative
Technology perspective	Humanity	<ul style="list-style-type: none"> <li>• naturalness</li> <li>• maintaining themed discussion</li> <li>• responding to specific questions</li> <li>• non-understanding rate</li> </ul>	<ul style="list-style-type: none"> <li>• Turing Test</li> <li>• rating scale</li> <li>• percentage of success</li> <li>• percentage of rejection</li> </ul>	Qualitative, Quantitative
Business perspective	Business value	<ul style="list-style-type: none"> <li>• efficiency cost</li> <li>• qualitative cost</li> </ul>	<ul style="list-style-type: none"> <li>• number of users</li> <li>• duration of the chatbot conversation</li> <li>• number of the chatbot conversations</li> <li>• number of the agents included in conversation</li> <li>• duration of the conversation with agent</li> <li>• number of the unsuccessful conversations</li> <li>• number of the unsuitable responses</li> <li>• number of repeated queries</li> </ul>	Quantitative

The application of a specific perspective or a mixture of perspectives depends on the type of chatbot that needs to be evaluated. Each perspective has its benefits, but also disadvantages. For instance, user experience perspective is the most common qualitative approach, which can provide a lot of information about user satisfaction, but it can also require very broad research and thus be expensive. On the other hand, information retrieval perspective can be used for quantitative evaluation of chatbot, but it does not provide any information related to user experience. Linguistic perspective relies on judgement of experts, but it could be required in order to evaluate complex and more sophisticated chatbots. Technology perspective can provide a feedback on the level of AI integrated within the chatbot, but does not give any information about user satisfaction. Finally, business perspective evaluation can provide the feedback related to the results and effects of the chatbot, thus helping to assess its appropriateness and validity. On the other hand, this perspective does not provide any details about users motivation to use chatbot nor feedback to improve the performance of chatbot. Proposed framework can be used in order to propose the appropriate evaluation approach and corresponding metrics for certain chatbot. Not all chatbots need to be evaluated by all five perspectives. The evaluation process and the combination of different perspectives should rather be aligned with different areas of chatbot application and with the needs of users. For instance, small companies could measure the business value and the user experience in order to be able to facilitate business processes and meet expectations of their users. On the other hand, big companies with well-established automated business processes and loyal clients could use the multiple perspectives of the evaluation to be able to meet the requirements of the most demanding users and to meet the highest possible technology and linguistic standards.

#### **4. CONSLUSION**

This paper provides a review on the current evaluation metrics available for measuring success of the chatbot, and proposes the chatbot evaluation framework based on five perspectives: user experience perspective, information retrieval perspective, linguistic perspective, technology perspective and business perspective. It proposes 14 categories for chatbot evaluation that should be analyzed: usability, performance, affect, satisfaction, accuracy, accessibility, efficiency, quality, quantity, relation, manner, grammatical accuracy, humanity and business value. It also proposes appropriate qualitative and quantitative metrics related to stated categories. The choice of the evaluation perspective should be based on the needs of the chatbot users, meaning the evaluation should be aligned with the different areas of chatbot application. Focusing solely on technology does not guarantee success, and thus the appropriate strategy of the chatbot evaluation should be carefully considered. This research combines different approaches and chatbot attributes extracted from various scientific papers dealing with chatbot evaluation metrics, and it can help researchers to identify opportunities for the future research in this area.

#### **LITERATURE:**

1. Brandtzaeg, P. B., & Følstad, A. (2017). Why People Use Chatbots. In I. Kompatsiaris, J. Cave, A. Satsiou, G. Carle, A. Passani, E. Kontopoulos, ... D. McMillan (Eds.), *Internet Science* (Vol. 10673, pp. 377–392). Cham: Springer International Publishing. [https://doi.org/10.1007/978-3-319-70284-1\\_30](https://doi.org/10.1007/978-3-319-70284-1_30)
2. Cahn, J. (2017). CHATBOT: Architecture, Design, & Development, 46.
3. Chakrabarti, C., & Luger, G. F. (2012). A Framework for Simulating and Evaluating Artificial Chatter Bot Conversations, 6.
4. Coniam, D. (2015). The linguistic accuracy of chatbots: usability from an ESL perspective.

5. Hung, V., Elvir, M., Gonzalez, A., & DeMara, R. (2009). Towards a method for evaluating naturalness in conversational dialog systems. In *2009 IEEE International Conference on Systems, Man and Cybernetics* (pp. 1236–1241). San Antonio, TX, USA: IEEE. <https://doi.org/10.1109/ICSMC.2009.5345904>
6. Io, H. N., & Lee, C. B. (2017). Chatbots and conversational agents: A bibliometric analysis (pp. 215–219). IEEE. <https://doi.org/10.1109/IEEM.2017.8289883>
7. Jwalapuram, P. (2017). Evaluating Dialogs based on Grice's Maxims (pp. 17–24). Presented at the RANLP 2017 - Student Research Workshop. [https://doi.org/10.26615/issn.1314-9156.2017\\_003](https://doi.org/10.26615/issn.1314-9156.2017_003)
8. Kuligowska, K. (2015, February). Commercial Chatbot: Performance Evaluation, Usability Metrics and Quality Standards of Embodied Conversational Agents.
9. Pereira, J., & Díaz, O. (2018). A quality analysis of facebook messenger's most popular chatbots. In *Proceedings of the 33rd Annual ACM Symposium on Applied Computing - SAC '18* (pp. 2144–2150). Pau, France: ACM Press. <https://doi.org/10.1145/3167132.3167362>
10. Radziwill, N., & Benton, M. (2017). Evaluating Quality of Chatbots and Intelligent Conversational Agents, 21.
11. Russell-Rose, T. (2017). A framework for chatbot evaluation. Retrieved from <https://isquared.wordpress.com/2017/01/24/a-framework-for-chatbot-evaluation/>
12. Schumaker, R. P., Ginsburg, M., Chen, H., & Liu, Y. (2007). An evaluation of the chat and knowledge delivery components of a low-level dialog system: The AZ-ALICE experiment. *Decision Support Systems*, 42(4), 2236–2246. <https://doi.org/10.1016/j.dss.2006.07.001>
13. Semeraro, G., Andersen, H. H. K., Andersen, V., Lops, P., & Abbattista, F. (2003). Evaluation and Validation of a Conversational Agent Embodied in a Bookstore. In N. Carbonell & C. Stephanidis (Eds.), *Universal Access Theoretical Perspectives, Practice, and Experience* (Vol. 2615, pp. 360–371). Berlin, Heidelberg: Springer Berlin Heidelberg. [https://doi.org/10.1007/3-540-36572-9\\_28](https://doi.org/10.1007/3-540-36572-9_28)
14. Shawar, B. A., & Atwell, E. (2007). Different measurements metrics to evaluate a chatbot system. In *Proceedings of the Workshop on Bridging the Gap Academic and Industrial Research in Dialog Technologies - NAACL-HLT '07* (pp. 89–96). Rochester, New York: Association for Computational Linguistics. <https://doi.org/10.3115/1556328.1556341>
15. Venkatesh, A., Khatri, C., Ram, A., Guo, F., Gabriel, R., Nagar, A., ... Raju, A. (2018). On Evaluating and Comparing Conversational Agents. *ArXiv:1801.03625 [Cs]*. Retrieved from <http://arxiv.org/abs/1801.03625>
16. Zamora, J. (2017). I'm Sorry, Dave, I'm Afraid I Can't Do That: Chatbot Perception and Expectations. In *Proceedings of the 5th International Conference on Human Agent Interaction - HAI '17* (pp. 253–260). Bielefeld, Germany: ACM Press. <https://doi.org/10.1145/3125739.3125766>

# “GREEN” MANAGERIAL DELEGATION AND ENVIRONMENTAL CORPORATE SOCIAL RESPONSIBILITY IN DIFFERENT MARKET STRUCTURES

**Domenico Buccella**

*Department of Economics, Kozminski University in Warsaw, Poland  
buccella@kozminski.edu.pl*

**Michał Wojna**

*Department of Economics, Kozminski University in Warsaw, Poland  
michwoj@kozminski.edu.pl*

## **ABSTRACT**

*Assuming Cournot competition in a duopoly industry characterized by the presence of polluting production processes, this work studies the firms' choice to engage in Environmental Corporate Social Responsibility (ECSR) (modeled as an investment in cleaning technology) by means of “green” managerial delegation. In other words, a firm hires a manager with preferences for environmental concerns and to whom the firms' owners delegate both sales and the decision with regard to the optimal level of green technology adoption. When the duopoly is the given market structure of the industry, if the environmental sensitivity of the “green” managers is extremely low, then the engagement in ECSR is the firms' dominant strategy, regardless the efficiency level of the available abatement technology. Nonetheless, firms are cast into a prisoner's dilemma situation. On the other hand, if the “green” manager has low-intermediate/intermediate environmental sensitivity levels, then it occurs that either no ECSR, multiple symmetric equilibria, or ECSR engagement emerge in equilibrium, depending on the efficiency levels of the available abatement technology. Finally, if the environmental sensitivity of the managers is adequately high, then firms do not engage in ECSR, regardless of the efficiency level of the abatement technology. When it is considered a market entry game in which the entrant has to follow the established common practice in the industry, it is shown that an incumbent firm can strategically adopt ECSR for entry deterrence reasons. These results provide additional reasons for the recently observed widespread diffusion of ECSR activities related to carbon emissions reductions and their reporting.*

**Keywords:** *Environmental Corporate Social Responsibility, “Green” Managerial Delegation, Duopoly, Monopoly, Entry deterrence*

## **1. INTRODUCTION**

In recent decades, companies' adoption of socially responsible behaviors has become a common business practice, particularly engagement in Environmental Corporate Social Responsibility (ECSR), such as reducing carbon emissions. In fact, KPMG (2015) states that the worldwide rate of carbon reporting of the G250 Fortune Index (the largest global multinationals) is 82 percent, with rates ranging in the 14 surveyed sectors from 67 percent (personal and household goods) to 100 percent (food and beverages). All of those companies are characterised by the separation between ownership and control, which is delegated to managers. Using a modern game-theoretic approach, Vickers (1985), Fershtman and Judd (1987), and Sklivas (1987) have shown that the rationale for the separation between ownership and control can be essentially based on strategic reasons: hiring managers instructed to behave more aggressively in the market, forcing rivals to reduce output, and raising market shares and profits. However, those authors abstract from the fact that large companies want to follow ECSR. Maxwell et al. (2000) and Antweiler (2003) affirm that companies spontaneously adopt ECSR to neutralize the governments' regulatory threat, which allows companies to circumvent

more severe regulations. In a Stackelberg duopoly model with price competition in which firms select whether to engage in ECSR, Hirose et al. (2017) show that firms may strategically decide to adopt ECSR because it represents a commitment device. In contrast to the classical second-mover advantage observed in a standard duopoly with price leadership, the aforementioned authors reveal that the first-mover has the advantage: the leader does not engage in ECSR while the follower does, and the profits of both firms in equilibrium increases. This result may help to explain the recent trend of ECSR adoption. The present work takes a different route. Introducing the figure of the “green” manager with environmental concerns (Wright et al., 2012), in a Cournot duopoly, ECSR can arise in equilibrium because of the firms’ strategic interactions in the product market. Moreover, in a market entry game, the incumbent’s strategic decision to engage in ECSR is to deter entry in a context in which the entrant must follow the common industry practice in place. The rest of this paper is organized as follows. Section 2 introduces the setup for the analysis, and Section 3 concludes our findings and outlines future research.

## 2. THE MODEL AND THE RESULTS

Let us consider a duopoly industry in which Firm 1 and Firm 2 compete in quantities (Cournot competition). Firms produce homogeneous goods for the market, and each unit of the goods produced causes  $k$  unit of pollution. Firms exhibit a constant return to scale technology with linear, constant marginal costs. It is assumed that a cleaning technology is available. However, following Asproudis and Gil-Moltó (2015), the absence of a technology that can completely eliminate emissions, that is  $k > 0$ , is assumed. With regard to the assumption of the abatement cost function, the pollution abatement cost ( $CA$ ) is  $CA = z(1-k)^2$ ,  $z > 0$ . Adoption of the cleaner technology requires fixed costs with decreasing returns to investment; i.e. the emission’s abatement always entails some costs. Therefore, given that  $k$  is the pollution per unit of production, a reduction (resp. an increase) of  $k$  is related to a more (resp. less) efficient abatement technology: an identical level of polluting emission can be abated in a less (resp. more) expensive way. The parameter  $z$  scales up/down the total abatement cost; therefore, it represents a measure of the abatement technology’s efficiency. In other words, this approach applying the firms’ pollution abatements demonstrates the Environmental Corporate Social Responsibility (ECSR); i.e. a reason for profit-oriented firms to engage in socially responsible activities. However, to implement the ECSR, firms hire a “green” manager with environmental sensibility (see Wright et al., 2012) to whom are delegated both the choice of the output and emission levels. In other words, to hire a “green” manager represents the firm’s commitment to engage in ECSR. As in Bughin (1999) and Buccella (2011, 2016), this paper analyzes two alternative market structures: 1) a given duopoly and 2) a monopoly with threat of entry. However, with regard to the entry modes, the work focuses only on the committed industry practice: the incumbent firm selects whether to engage in ECSR, and then the entrant “joins the pack,” that is, it follows the prevailing industry practice. The game is solved in the backward induction method to obtain sub-game perfect Nash equilibria. The sequence of moves is as follows. In the first stage, the firms decide whether to engage in ECSR. In the case of duopoly, if the firms opt not to engage in ECSR, a standard Cournot game takes place in which the owners decide the optimal output. If firms engage in ECSR via “green” delegation, the owners first decide the bonus in the manager compensation, and then the “green” manager decides on the emission level and the output. In the case of monopoly with threat of entry, the following apply: 1) without ECSR, in the second stage, on the basis of its possibilities, the potential entrant decides whether to enter the industry, whereas in the third stage, firms engage in Cournot competition, choosing profit-maximizing quantities and realizing output; 2) with ECSR, at stage two, the competitor decides whether to enter; in that case, at stage three, firms decide on

their bonus for the manager. Finally, at stage four, managers select emissions and quantities competing à la Cournot.

### 2.1. Monopoly outcomes

The monopoly market structure is first analyzed. The (inverse) linear demand for goods is  $p = a - q_1$ , where  $p$  denotes the market price (the slope of the demand parameters is normalized to 1) and  $q_1$  the monopolist output. First, consider the case of a non-environmentally concerned monopolist ( $k = 1$ ). The profits are  $\pi_1 = (a - q_1 - c)q_1$ , whose maximization yields  $q_1^{SM} = (a - c)/2$ , the optimal output for the monopolist. Substitution of the optimal output into the profits' function leads to the monopolist profits,  $\pi_1^{MS} = (a - c)^2/4$ , where the upper script *MS* stands for "monopoly standard."

Consider now the case of ECSR adoption ( $k \in (0, 1)$ ). The monopolist's profit function now is

$$\pi_1 = (a - q_1 - c)q_1 - z(1 - k)^2. \quad (1)$$

To implement ECSR, the owners hire a "green" manager to whom is offered a public observed contract whose remuneration is formulated as  $R = A + BU \geq 0$ , where  $A \geq 0$  is the fixed salary component of the manager's compensation,  $B \geq 0$  is a constant parameter, and  $U$  is the manager's utility. Therefore, by offering the "green" manager a contract, the firm commits to ECSR. Without loss of generality, the fixed salary component is set equal to zero and  $B$  equal to one. The monopolist manager's utility takes the following form (see Vickers, 1985; Jansen et al., 2007, 2009; Fanti and Meccheri, 2013):

$$U_1 = \pi_1 + (b_1 - ek)q_1, \quad i = 1, 2, \quad (2)$$

Figure 1: Managerial bonus as a function of the environmental concern.

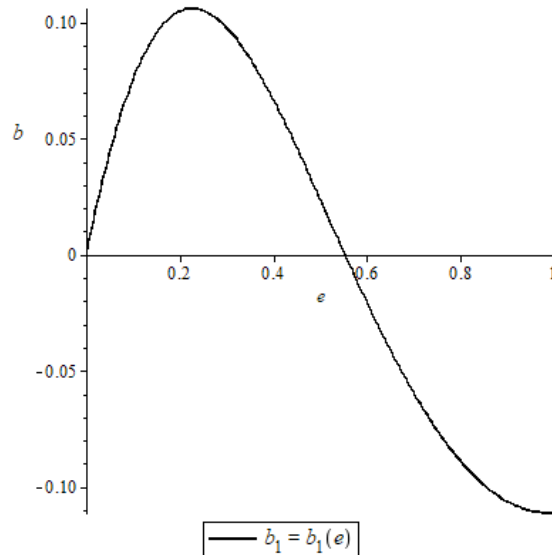

parameter set :  $a = 1, c = 0, z = \frac{1}{5}$

Source: Authors' calculations



where  $\pi_1$  are profits in (1),  $b_1$  is the owners' incentive (disincentive) concerning the manager's choice of quantity, and the parameter  $e > 0$  is the publicly known managers' sensitivity to environmental damage, assumed to be identical across managers in the same industry. In other words, the environmental sensitivity is not the managers' private information. This can be a plausible assumption if one thinks that the manager's environmental sensitivity can be identified, for example, by his or her previous engagement in ECSR activities in other companies and attendance in environmental conferences, seminars, and similar events. To guarantee positive output and an interior solution in the selection of the abatement technology, it is assumed that  $a - c > e$ . Maximization of (2) with respect to quantity leads the manager to choose the optimal output level,  $q_1 = (a - c + b - ek)/2$ . Substituting the optimal output into (2) and maximizing  $k$ , the optimal emission level is  $k_1 = [(a - c + b)e - 4z]/(e^2 - 4z)$ . To ensure an interior solution in the selection of the abatement technology, it is assumed that  $2\sqrt{z} > e$ . Substituting the optimal quantity and emission levels into (1), the profits can be expressed as follows

$$\pi_1 = \frac{z(a + b_1 - c - e)[(3a + b_1 - 3c)e^2 - 4z(a - b_1 - c + e) - e^3]}{(e^2 - 4z)^2}. \quad (3)$$

The owners maximize (3) with respect to the bonus, and optimization yields

$$b_1 \equiv -\frac{e[2e(a - c) - e^2 - 4z]}{(e^2 + 4z)^2} \begin{matrix} > \\ < \end{matrix} 0 \Rightarrow e \begin{matrix} < \\ > \end{matrix} a - c - \sqrt{(a - c)^2 - 4z} \quad (4)$$

which implies that  $z \in (0, (a - c)^2/4]$ , i.e. the abatement technology must not be excessively efficient. An analytical inspection of (4) reveals that the owners select a bonus incentive to moderate the negative impact of the manager environmental sensitivity on output sales when it is not too excessive, while owners find it is optimal to penalize further output sales when the manager is adequately environmentally oriented. Figure 1 shows the relation between the managerial bonus and the environmental concern. The intuition behind these results is as follows. If the manager's environmental concern is sufficiently low, the abatement cost is not excessively high, and thus the owners can partially alter the manager's objective through a positive bonus to soften the negative impact on sales. On the other hand, if the environmental concern is high, the abatement cost can become prohibitive; as a consequence, a penalty for production induces the manager to reduce sales and, in turn, the optimal emission level.

Substituting (4) into (3), the equilibrium profits are

$$\pi_1^{ME} = \frac{z(a - c)^2}{e^2 + 4z} \quad (5)$$

where the upper script *ME* stands for "monopoly with ECSR".

## 2.2. Duopoly outcomes

Let us now consider the duopoly market structure. First, the results with non-environmentally concerned firms are derived. The (inverse) linear demand for goods is now  $p = a - Q$ , with  $p$  denoting the market price and  $Q = \sum_i q_i$ ,  $i = 1, 2$  total production.

Thus, the firms' profits are

$$\pi_1 = (a - Q - c)q_1, \quad \pi_2 = (a - Q - c)q_2 \quad (6)$$

for Firms 1 and 2, respectively. Standard optimization of (6) leads to the reaction functions  $q_i = (a - q_j - c)/2$ ,  $i = 1, 2$ ,  $i \neq j$ , from which the optimal output,  $q_i = q_j = (a - c)/3$ , and the equilibrium profits are obtained

$$\pi_1^{DNE} = (a - c)^2/9, \quad \pi_2^{DNE} = (a - c)^2/9 \quad (7)$$

where the upper script *DS* stands for "duopoly no ECSR" industry.

Consider now the case of ECSR adoption ( $k \in (0, 1)$ ). The profit functions now have the following form

$$\pi_1 = (a - Q - c)q_1 - z(1 - k)^2, \quad \pi_2 = (a - Q - c)q_2 - z(1 - k)^2. \quad (8)$$

Therefore, the managers' utility is now

$$U_i = \pi_i + (b_i - ek_i)q_i, \quad i = 1, 2, \quad (9)$$

where  $\pi_i$  is as in (8). Maximization of (9) leads to the managers' reaction functions, given by  $q_i = (a - q_j - c + b_i - ek_i)/2$ ,  $i = 1, 2$ ,  $i \neq j$ . Solving the system composed by the reaction functions, the optimal output is  $q_i = [a - c + 2(b_i - ek_i) - (b_j - ek_j)]/3$ . After substitution of the optimal production into (9), maximization with respect to  $k_i$  leads to

$$k_i = \frac{2e^2k_j + [2(a - c) + 2(2b_i - b_j)]e - 9z}{4e^2 - 9z} \quad (10)$$

with  $\partial k_i / \partial k_j < 0$ : the emission level game is in strategic substitutes. To guarantee an interior solution in the selection of the abatement technology, it is assumed that  $(3/2)\sqrt{z} > e$ . A direct comparison reveals that the non-negativity condition on the choice of the abatement technology under duopoly is more restrictive than that under monopoly. Solving the system of the reaction functions in the emission level space, the equilibrium level of  $k$  is

$$k_i^* = \frac{[4(a - c + b_i)e^3 - 18e^2z - 6z(a - c + 2b_i - b_j)e + 27z^2]}{(2e^2 - 9z)(2e^2 - 3z)}, \quad i = 1, 2. \quad (11)$$

Inserting first (11) into the optimal output expression and then again (11) and the obtained expressions of output as function of the bonuses into (8), maximization with respect to  $b_i$  leads to the following reaction function in the bonus space:

$$b_i = \frac{[(-48a + 48c + 32b_j)e^8 - 216e^7z + 936e^6z(a - c - \frac{5}{13}b_j) - 108z^2e^5 - 3456z^2e^4(a - c - \frac{19}{32}b_j) + 3078e^3z^3 + 3726z^3e^2(a - c - b_j) - 3645ez^4 - 729(a - c - b_j)]}{32e^8 - 576e^6z + 1944e^4z^2 - 648e^2z^3 - 2916z^4}$$

Solving the system, the optimal bonus in equilibrium is

$$b_i = \frac{[(-81a + 81c - 405e)z^3 + 360e^2(a - c + \frac{e}{5})z^2 - 144(a - c - \frac{e}{4})e^4z + 8e^6(a - c)]}{9z(2e^2 + 9z)(2e^2 - 5z)} \quad (12)$$

Substituting (12) into (8), the equilibrium profits finally produce

$$\pi_i^{DE} = \frac{2(a - c)^2(27z^2 + 18e^2z - 8e^4)(27z^2 - 18e^2z + 2e^4)}{(5z - 2e^2)^2(2e^2 + 9z)z} \quad (13)$$

where the upper script *DE* stands for “duopoly with ECSR”. An analytical inspection of (13) reveals that  $\pi_i^{DE} \geq 0$  if  $(1/2)\sqrt{6z(3 - \sqrt{3})} \geq e \equiv e^T$  which is a technical condition more restrictive than  $(3/2)\sqrt{z} > e$ . To compare all the strategic profiles, it is assumed that in the rest of the paper the condition  $e \leq e^T$  always holds. Finally, consider the asymmetric case in which one firm does not engage in ECSR, while the rival does. Assume that the incumbent adopts ECSR, while the entrant does not (a similar reasoning applies for the opposite situation because the entrant’s fixed costs do not alter the choice of the relevant variables). The profit functions are

$$\pi_1 = (a - Q - c)q_1 - z(1 - k)^2, \quad \pi_2 = (a - Q - c)q_2 \quad (14)$$

for Firms 1 and 2, respectively. Thus, Firm 1’s manager utility is as in (9), while Firm 2 solves a pure profit-maximizing problem. Maximization of  $\pi_1$  in (14) leads to the manager’s reaction function  $q_i = (a - q_j - c + b_i - ek_i)/2$ , while for Firm 2 the reaction function is  $q_j = (a - q_i - c)/2$ . Solving the system composed by the firms’ reaction functions, the optimal output is  $q_1 = [a - c + 2(b_1 - ek_1)]/3$  for the incumbent and  $q_2 = [a - c - (b_1 - ek_1)]/3$  for the entrant. After substitution of the optimal production levels into  $\pi_1$  in (14), Firm 1’s manager maximization with respect to  $k_1$  leads to

$$k_1^* = \frac{2e(a - c + 2b_1) - 9z}{4e^2 - 9z}. \quad (15)$$

Inserting first (15) into the optimal output expression and the obtained expressions of output as function of the bonus into  $\pi_1$  in (14), the following is obtained:

$$\pi_1 = -\frac{z[a-c+2(b_1-e)][(10a+8b_1-10c)e^2-9z(a-b_1-c+e)-8e^3]}{(4e^2-9z)^2}. \quad (16)$$

The owners maximize (16) with respect to the bonus, and optimization yields

$$b_1 = -\frac{(28e^2-9z)(a-c)-4e(8e^2+9z)}{4(8e^2+9z)^2} \underset{<}{>} 0 \Rightarrow e \underset{>}{<} e(a,c,z). \quad (17)$$

Table 1: Firm's payoffs in duopoly

Firm 2 → Firm 1 ↓	ECSR	No ECSR
ECSR	$\frac{2(a-c)^2(27z^2+18e^2z-8e^4)}{(5z-2e^2)^2(2e^2+9z)z}; \frac{2(a-c)^2(27z^2+18e^2z-8e^4)}{(5z-2e^2)^2(2e^2+9z)z}$	$\frac{9(a-c)^2z}{8(e^2+9z)}; \frac{(16e^2+9z)^2(a-c)^2z}{16(8e^2+9z)^2}$
No ECSR	$\frac{(16e^2+9z)^2(a-c)^2z}{16(8e^2+9z)^2}; \frac{9(a-c)^2z}{8(e^2+9z)}$	$\frac{(a-c)^2}{9}; \frac{(a-c)^2}{9}$

Source: Authors' calculations

The analytical expression of the environmental sensitivity is algebraically complex and not reported for economy of space; however, the economic interpretation is qualitatively similar to the monopoly case. Substituting (17) into the output levels and then into (14), the equilibrium profits finally obtain

$$\pi_1^{DE/NE} = \frac{9(a-c)^2z}{8(e^2+9z)}, \quad \pi_2^{DE/NE} = \frac{(16e^2+9z)^2(a-c)^2z}{16(8e^2+9z)^2} \quad (18)$$

where the upper script *DE/NE* stands for “duopoly, one no ECSR/ one ECSR”.

## 2.3. Results

### 2.3.1. Duopoly given market structure

Consider first the case of duopoly as the given market structure. With the outcomes of the previous subsection, it is possible to construct Table 1. The intersections between all of the firms' duopoly outcomes in Table 1 and the condition  $e \leq e^T$  generate six regions in the relevant  $(z, e)$ -space, as Figure 2 depicts. In the regions I-VI of the  $(z, e)$ -space, the following duopoly profit rankings apply:

- Region I:  $\pi_1^{DNE/E} > \pi_i^{DN} > \pi_i^{DE} > \pi_1^{DE/NE}$ ,  $i=1,2$ . No ECSR is the dominant strategy for firms.
- Region II:  $\pi_i^{DN} > \pi_1^{DNE/E} > \pi_i^{DE} > \pi_1^{DE/NE}$ ,  $i=1,2$ . No ECSR is the dominant strategy for firms.
- Region III:  $\pi_i^{DN} > \pi_1^{DNE/E} > \pi_1^{DE/NE} > \pi_i^{DE}$ ,  $i=1,2$ . No ECSR is the dominant strategy for firms.
- Region IV:  $\pi_i^{DN} > \pi_1^{DE/NE} > \pi_1^{DNE/E} > \pi_i^{DE}$ ,  $i=1,2$ . No ECSR is the dominant strategy for firms.
- Region V:  $\pi_i^{DN} > \pi_1^{DE/NE} > \pi_i^{DE} > \pi_1^{DNE/E}$ ,  $i=1,2$ . Both no ECSR and ECSR arise as Nash equilibria, thus there are multiple symmetric equilibria.

- Region VI:  $\pi_1^{DE/NE} > \pi_i^{DN} > \pi_i^{DE} > \pi_1^{DNE/E}$ ,  $i=1,2$ . Engagement in ECSR is the dominant strategy for firms; however, the game has a prisoner's dilemma structure.

Those findings can be summarized in Proposition 1.

Figure 2: Duopoly profits in the  $(z, e)$ -space and game equilibria

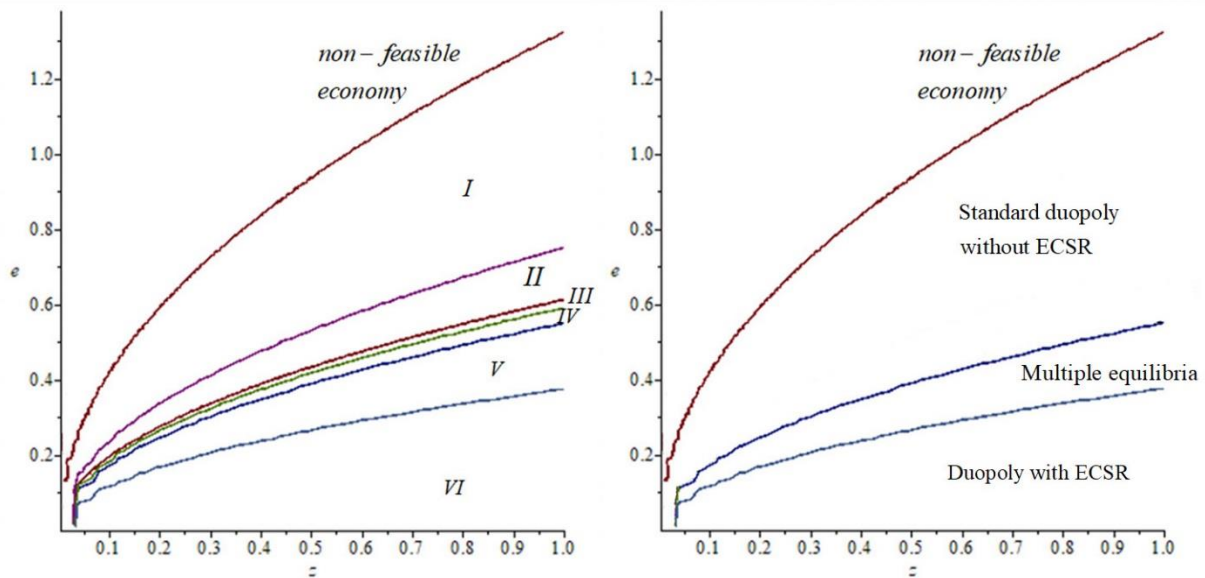

Note: the term  $(a-c)^2$  enters all expressions in the same way and, therefore, the functional forms in Table 1 are unaffected by it. The graphs are depicted assuming that  $(a-c)^2 = 1$ .

Source: Authors' calculations

Proposition 1: In a duopoly market: 1) if the environmental sensitivity of the managers is very low, then to hiring a “green” manager and engaging in ECSR is the dominant strategy for the firms, regardless of the efficiency level of the abatement technology. However, firms face a prisoner's dilemma situation. 2) If the environmental sensitivity of the managers is low/intermediate, then a) no ECSR arises if the abatement technology is low efficient, b) multiple symmetric equilibria emerges in equilibrium for intermediate efficiency levels of the abatement technology, and c) engagement in ECSR arises in equilibrium if the abatement technology is adequately efficient. 3) If the environmental sensitivity of the managers is sufficiently high, then the unique equilibrium is no “green” delegation and, thus, there is no ECSR engagement, regardless of the efficiency level of the abatement technology.

Thus, in a delegation game with environmental concerns, the set of equilibria is richer than in a standard delegation game. In fact, in a standard delegation game, managerial delegation is the unique equilibrium, and the game is characterized by a prisoner's dilemma. On the other hand, in the presence of “green” managers, mixed equilibria and no delegation arise as well. The rationale for this result can be explained as follows. If the environmental sensitivity of the manager is rather low, the usual mechanism of the managerial delegation (Vickers, 1985; Fershtman, 1985; Fershtman and Judd, 1987; Sklivas, 1987) applies: owners design compensation contracts to conduct a more aggressive behaviour to gain a competitive advantage in the market. On the other hand, if the managers' environmental concern is intermediate, the emerging equilibrium of the game depends on the efficiency of the abatement technology: if the technology has a low level of efficiency, the owners design a contract to expand output, but the overall cost reduction is low, therefore it is profitable not to hire the

“green” manager who engages in ECSR. Nevertheless, as long as the available technology is more efficient, it turns out that both symmetric equilibria arise and, when the abatement technology is extremely efficient, to engage in ECSR emerges in equilibrium. Finally, if the manager sensitivity is high, then the owners design a contract that tends to penalize excessively production, irrespective of the efficiency level of the abatement technology: not following ECSR becomes the dominant strategy.

### 2.3.2. Monopoly with threat of market entry

Consider now the case of threat of entry and “committed industry practice”; i.e. the entrant is forced to “join the pack”. In other words, if the incumbent is not engaged in ECSR, then the entrant does not join; if the incumbent engages in ECSR, so does the entrant. Entry is modeled as a change from a monopoly to a duopoly market structure. Post-entry competition occurs à la Cournot. Following the line of reasoning of Bughin (1999) and Buccella (2011, 2016), in the case of monopoly with the threat of market entry, under “committed industry practice,” the incumbent can strategically delegate output and the level of emission abatement to the “green” manager that invests in cleaning technology, therefore selecting engagement in ECSR as a strategic entry deterrence tool. Let us define Firm 1 as the incumbent and Firm 2 as the potential entrant. The potential entrant must face an exogenous fixed cost,  $G$ . Given the payoffs in the committed industry practice, a preliminary observation simplifies the subsequent analysis by concentrating on a restricted range of the entrant’s fixed costs.

Restriction 1  $\pi_1^{MS} > G > \pi_1^{DE}$ .

The economic intuition behind Restriction 1 is straightforward. In fact, if  $\pi_1^{DE} > G$ , the fixed costs are sufficiently low, thus always guaranteeing entry in the industry. On the other hand, if  $G > \pi_1^{MS}$ , the potential competitor has to face prohibitively high fixed costs so that market entry is always blockaded. Given Restriction 1, the following Lemma applies.

Lemma 1: The incumbent can strategically select to adopt ECSR to deter entry if the following conditions hold:

$$a) \pi_1^{MA} > G > \pi_1^{DA} \quad A = NE, E; \quad b) \pi_1^{MA} > G > \pi_1^{DB} \quad A, B = NE, E; A \neq B.$$

Conditions (a) – (b) in Lemma 1 require discussion. Condition (a) is rather straightforward; it states that, under committed industry practice, if the incumbent establishes a certain behavior (to engage/not to engage in ECSR) in an industry, then fixed costs higher than the duopoly profits under the established industry practice block the potential competitor, because entry is no longer profitable. On the other hand, condition (b) specifies that the duopoly profits with the alternative practice do not have to be larger than the monopoly profits of the established practice because the incumbent then finds an advantageous practice in establishing the alternative practice and accommodate entry. By applying Lemma 1 under Restriction 1 to the firms’ profits outcome, the next proposition directly follows.

Proposition 2: If the level of the social concern is  $e \leq e^T$ , under committed industry practice, the ECSR can always be used as a strategic market entry deterrence tool.

Proof: For  $e \leq e^T$ , the non-negativity constraint on the technology choice also ensures the non-negativity of quantities and profits under both monopoly and duopoly configurations.

It follows that, for  $e \in (0, e^T)$ , the ranking of the incumbent firm's profits is  $\pi_1^{MS} > \pi_1^{ME} > \pi_1^{DNE} > \pi_1^{DE}$ . Given Restriction 1, it follows that  $\pi_1^{MS} > \pi_1^{ME} > \pi_1^{DNE} > G > \pi_1^{DE}$ , and the adoption of ECSR simultaneously fulfills conditions (a) – (b) in Lemma 1. In fact, if the incumbent selects not to engage in ECSR, the level of the fixed costs is such that entry cannot be impeded. As a consequence, the incumbent obtains  $\pi_1^{DNE}$ . However, if the incumbent strategically commits to engagement in ECSR activities, the potential competitor can no longer enter the market, and the incumbent obtains  $\pi_1^{ME} > \pi_1^{DNE}$ .

Proposition 2 simply states that, if the green manager's environmental concern is not excessive, then the incumbent, by hiring her/him, can always use the adoption of ECSR as an effective strategic tool to deter potential entry in the industry.

### 3. CONCLUSION

Using a simple Cournot model in an industry with polluting production processes, this work has investigated the firms' choice to engage in ECSR through "green" managerial delegation, hiring a manager with environmental concerns to whom the owners delegate both sales and the decision regarding the optimal level of cleaning technology. In a given duopoly, it has been shown that, if the "green" managers' environmental sensitivity is very low, engagement in ECSR is the dominant strategy regardless of the efficiency level of the available abatement technology; however, firms face a prisoner's dilemma. On the other hand, if the "green" manager has a low/intermediate environmental sensitivity, then no ECSR, multiple symmetric equilibria, or ECSR engagement will emerge, depending on the efficiency levels of the abatement technology. Finally, if the environmental sensitivity of the managers is sufficiently high, then firms do not engage in ECSR, regardless the efficiency level of the abatement technology. On the other hand, in a monopoly with the threat of entry, where the entrant follows the established common practice in the industry, an incumbent firm can strategically engage in ECSR for entry deterrence reasons. These results add additional and alternative reasons for the recently observed widespread diffusion of ECSR activities related to carbon emission reductions and their reporting. The paper builds on a set of precise assumptions. To check the robustness of the results, a first, suitable direction of research is whether the Bertrand competition mode with differentiated products can alter the equilibria of the game. Finally, an overall welfare analysis is necessary in order to investigate the government's potential regulatory intervention.

**ACKNOWLEDGEMENT:** *This article has received financial support from the statutory funds for research activities of the Kozminski University.*

### LITERATURE:

1. Asproudis, E., Gil-Moltó, M.J. (2015). Green Trade Unions: Structure, Wages and Environmental Technology. *Environmental and Resource Economics* 60(2) (pp. 165-189).
2. Antweiler, W. (2003). How effective is green regulatory threat? *American Economic Review* 93(2) (pp. 436–441).
3. Buccella, D. (2011). Corrigendum to "The strategic choice of union-oligopoly bargaining agenda" [Int. J. Ind. Organ. 17 (1999) 1029–1040]. *International Journal of Industrial Organization* 29(6) (pp. 690-693).
4. Buccella, D. (2016). Profit sharing as entry deterrence mechanism. *Portuguese Economic Journal* 15(1) (pp. 17-31).
5. Bughin, J. (1999). The strategic choice of union–oligopoly bargaining agenda. *International Journal of Industrial Organization* 17(7) (pp. 1029-1040).

6. Fanti, L., Meccheri, N. (2013). Managerial Delegation under Alternative Unionization Structures. *Labour* 27(1) (pp. 38-57).
7. Fershtman, C., Judd, K. (1987). Equilibrium incentives in oligopoly. *American Economic Review*, 77 (pp. 927-940).
8. Hirose, K., Lee, S.H., Matsumura, T. (2017). Environmental corporate social responsibility: A note on the first-mover advantage under price competition. *Economics Bulletin* 37(1) (pp. 214-221).
9. Jansen, T., van Lier, A. van Witteloostuijn, A. (2007). A note on strategic delegation: the market share case. *International Journal of Industrial Organization* 25 (pp. 531-539).
10. Jansen, T., van Lier, A. van Witteloostuijn, A. (2009). On the impact of managerial bonus systems on firm profit and market competition: the cases of pure profit, sales, market share and relative profits compared. *Managerial and Decision Economics* 30 (pp. 141-153).
11. Maxwell, J.W., Lyon, T.P., Hackett S.C. (2000). Self-regulation and social welfare: The political economy of corporate environmentalism. *Journal of Law and Economics* 43(2) (pp. 583–617).
12. Sklivas, S.D. (1987). The strategic choice of managerial incentives. *RAND Journal of Economics*, 18 (pp. 452–458).
13. Vickers, J. (1985). Delegation and the theory of the firm. *Economic Journal* 95, 138-147.
14. Wright, C., Nyberg, D., Grant, D. (2012). “Hippies on the third floor”: Climate change, narrative identity and the micro-politics of corporate environmentalism. *Organization Studies* 33(11) (pp. 1451-1475).



## THE PROBLEMATICS OF USING MOBILE DEVICES FOR E-COMMERCE IN THE V4 COUNTRIES

**Radovan Bacik**

*University of Prešov in Prešov, Faculty of Management, Slovakia  
radovan.bacik@unipo.sk*

**Richard Fedorko**

*University of Prešov in Prešov, Faculty of Management, Slovakia  
richard.fedorko@unipo.sk*

**Maria Olearova**

*University of Prešov in Prešov, Faculty of Management, Slovakia  
maria.olearova@smail.unipo.sk*

### **ABSTRACT**

*Based on Google Consumer Barometer data, the objective of this article is to explore the specifics of consumer buying behaviour within the Visegrád Four countries, focusing on the use of mobile devices in the purchasing process. Mobile devices are also a reflection of the changing purchasing habits of an increasingly demanding consumer. Mobile devices and integrated technologies serve not only as a means of purchasing products, but also have an irreplaceable position at all stages of the entire purchasing process. Many research also draw attention to the strength of their potential, which reflects the changing dynamics of e-commerce. The present article therefore captures the preferences of V4 consumers in terms of the use of different types of Internet access devices, identifies the activities that the consumers of the monitored countries perform through smart phones, and also focuses on defining the types of devices through which consumers search for and buy products.*

**Keywords:** *M-commerce, Smartphone, Mobile shopping, Mobile apps, E-commerce*

### **1. INTRODUCTION**

Nowadays, the adoption and use of modern technologies is for the current time we live in. The reason is the inclusion of these technologies in the everyday life of people is taking on importance much more than ever before (Štefko, Gburová, Matušíková, 2016). It should be noted that over the last two decades, mobile devices have not only caused intense outbursts in the world of digitization but also have a profound impact on changing consumer behaviour. The increasing availability and deployment of a thorough mobile industry has provided organizations with new revenue opportunities and mobile commerce has generally been identified as the next dimension of business development (Hameed et al., 2010; Gburová, Matušíková, 2017). Chong (2013) states that the retail sector has seen the tremendous potential of mobile technology, which has led to mobile purchasing and close cooperation with customers. Natarajan (2018) states that the development of mobile commerce has been stimulated by two factors - the large and fast penetration of the mobile phone and the remarkable and favorable convenience in terms of time and place (Gburová, Matušíková, Benková, 2015). In general, it can be argued that mobile commerce allows users to browse or purchase products through mobile devices anytime, anywhere (Michael, 2015; Hung et. al., 2012). In the case of a terminological definition, a mobile transaction is referred to as any transaction, whether direct or indirect, with the realization of the monetary value through the wireless telecommunication network (Beaconstac, 2016; Štarchoň, Lizbetinova, Weberová, 2016). Groß (2015), states that mobile commerce also includes the use of mobile devices for searching, viewing, comparing and purchasing products and services in the online environment.

Mobile commerce also means buying and selling goods or services, or even activities such as mobile banking, brokerage, shopping, money transfer, mobile ATMs, mobile tickets, mobile vouchers, coupons, loyalty cards, mobile auctions, etc. (Endre, 2009; Mura, Zulová, Madleňák, 2016). A more recent look at the issue speaks of mobile commerce as an explosion of applications and services that are accessible from mobile devices with the Internet. Thanks to them we are much closer to the information than ever before (Yang, et. al., 2012; Bačík, Nastišin, Gavurová, 2017). Among other things, mobile commerce includes various online services available on mobile devices through mobile websites and apps (Zhang et al., 2013; Bačík, Gburová, Štefko, 2015). It is worth mentioning the fact that the use of mobile apps is growing much faster than most other mobile application categories (Simon, 2015; Corba, Nastišin, 2016). Some authors draw attention to the number of available mobile commerce sub-tools, but highlight in particular the three main sub-areas of m-banking, m-payments and m-shopping. It should be emphasized that the implementation of mobile commerce activities in business strategies provides consumers with an additional purchasing platform. From the seller's point of view, it increases the likelihood of initial interest and consequently income (Hung et al., 2012; Weberová, Štarchoň, Lizbetinova, 2016).

## **2. METHODOLOGY**

The objective of our analysis was to examine selected specifics of consumer behaviour in the Visegrád Four countries (the Czech Republic, Hungary, Poland, Slovakia), focusing on the use of mobile devices in the purchasing process. Our analysis is based on available Google Consumer Barometer data, which summarizes the results of the Connected Consumer Survey and the Consumer Barometer Survey. Google's partners in these analyses are TNS, IAB Europe, Hive and Graphic. Consumer Barometer is a tool to help us understand how people use the Internet all over the world. These analyses globally map internet usage, consumer behaviour and Internet user preferences. This analysis included 56 countries of the world. Respondents were than 16 years old. Within the Connected Consumer Survey, the sample size was 1 000 respondents in each surveyed country. Surveys were administered by TNS Infratest on behalf of Google. Survey data was collected in all countries via telephone (CATI) or face-to-face interviewing (CAPI/PAPI). Questionnaires were administered in local language(s) for all surveyed countries. The interview length was 25 min. on average for telephone interviews and 30+ minutes for face-to-face interviews. Data was weighted according to local Census data. Enumeration surveys were administered in 2014, 2015 and 2017. In order to meet our target, we have focused on identifying the types of devices through which V4 users connect to the Internet, we have mapped out the activities that consumers perform more on smartphones than computers, and we also define the features that respondents use in their smartphones every day. We then identified, through which types of devices consumers are looking for product information, and by what types of devices they purchase products in the online environment. At the end of this article, we point out the stages of the buying process that are being used by consumers in the V4 countries via smartphones.

## **3. RESULTS**

The objective of our analysis was to examine selected specifics of consumer behaviour in the Visegrád Four countries (the Czech Republic, Hungary, Poland, Slovakia), focusing on the use of mobile devices in the purchasing process. The constant development of mobile technologies is a reflection of changing consumer habits. Changing available technologies also brings change of shopping channels, which consumers prefer more and more. Many studies have been devoted to m-commerce issues, and many surveys have revealed that in the near future, smartphones will not only be the devices for communication and entertainment, but also a means of purchasing goods and services.

This is also evidenced by the eMarketer (2018) statistics, according to which sales of retail e-commerce reached 2.3 trillion dollars in 2017, an increase of 23.2% over the previous year. The share of mobile devices on this market amounted to 58.9% of total e-commerce sales in the relevant year, which in financial terms represents 1.4 trillion dollars. In 2018, the share of m-commerce in the overall e-commerce would still be 4.6 percentage points higher and should therefore reach 1.804 trillion dollars, representing a total of 63.5% of e-commerce. The portal predicts that in 2021 mobile e-commerce could reach 3.5 trillion dollars, which would account for nearly three quarters (72.9%) of total e-commerce sales.

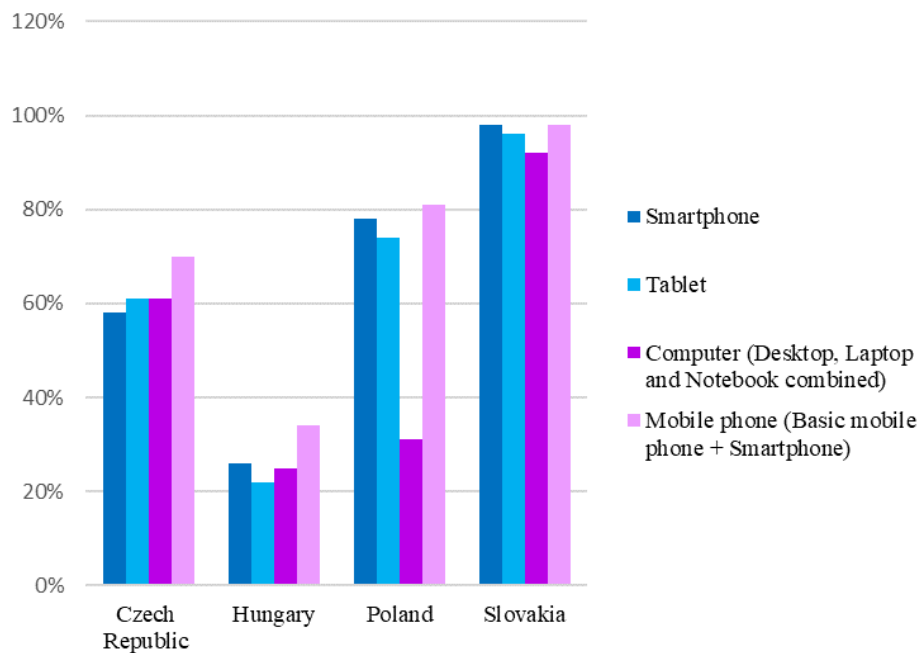

Figure 1: Types of the devices used (Consumer barometer 2018a)

Based on Consumer Barometer data (2018a), we chose to analyse the use of devices through which users connect to the Internet. In the framework of this analysis, 4 007 respondents were approached, the survey being conducted in 2017. Based on data published on the Consumer Barometer Portals in the case of the use of equipment that the respondents were currently using dominated devices within the computer group (desktop, laptop and netbook combined). In Slovakia, up to 81% of users use computer (desktop, laptop and netbook combined) for online activities. Similarly, 78% of users use it in the Czech Republic and Poland. In Hungary it is the least used device (Desktop, Laptop and Netbook combined), where 74% of users use it online. Smartphone is the most used in Slovakia (65%). In Hungary and Poland, it is used to the same extent, which is 61%. The least used in the Czech Republic (58%). When looking at the use of traditional mobile phones, 40% of the users use it in the Czech Republic, 35% in Hungary, 32% in Slovakia, and 31% in Poland. Tablet is the most used device in Slovakia (34%). In the Czech Republic, 26% uses it and in Poland 25%. The tablet is the least used in Hungary, where it is used by 22% of the consumers. Based on the figure below, we can see that the tablet in the three V4 countries does not reach even 50% of the smartphone share. Subsequently, through the available data from Consumer Barometer (2018b), we have identified what activities people perform more often through smartphones than through computers. The survey was conducted in 2017 and was attended by a total of 3.069 respondents. From the figure below, we can see that among the V4 countries the most people who prefer the smartphone in front of computers to buy products/services are from Poland with 24%, while only few people (16%) prefer smartphones in the Czech Republic.

However, the most frequently performed activity that users perform more on smartphones than computers is the use of search engines across all surveyed countries. Small screens, which are the great advantage of smart phones, are likely to reflect higher preferences in terms of performing the activity on the device. Smartphone users have search engine availability whenever and wherever. A remarkable difference was observed when visiting social networks. While respondents from the Czech Republic (44%), Poland (52%) and Slovakia (43%) most often prefer smartphones instead of computers to use search engines, the biggest group, 54% of the Hungarian respondents uses the mobile phones to perform mobile activities. On the other hand, V4 country respondents probably prefer computers rather than smartphones for playing games. Among all the activities that are being surveyed, playing games is the least executed activity. While 14% of the respondents prefer playing games in Hungary, the number only represents 5% in Slovakia.

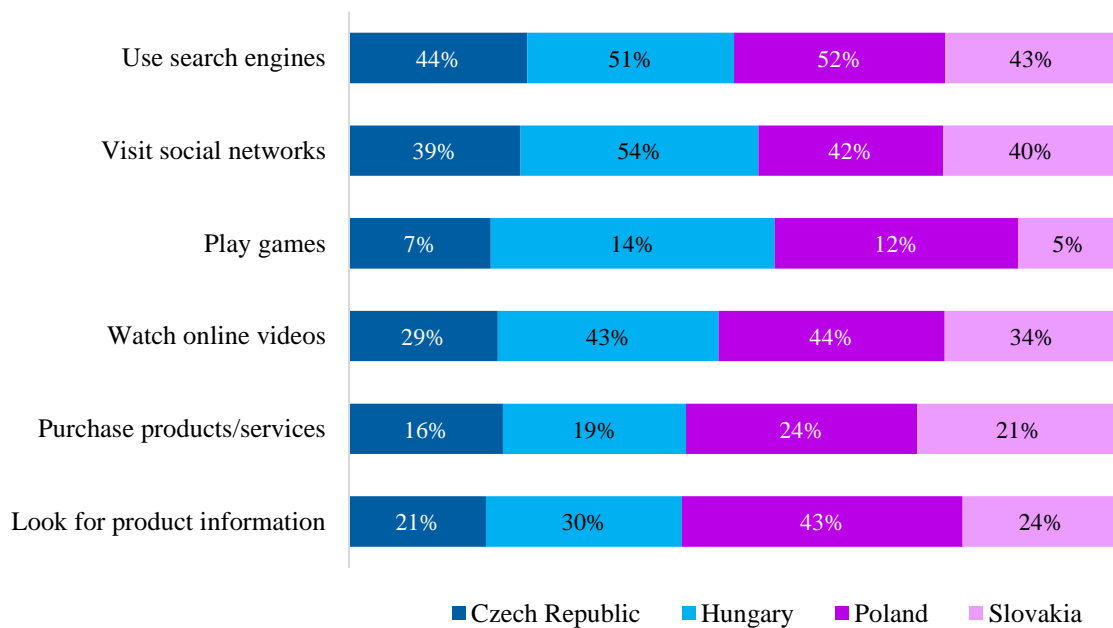

Figure 2: Activities performed more frequently via smartphones than via computers (Consumer barometer 2018b)

In our interest, there was a further finding regarding the use of mobile devices in e-commerce terms. Through data from the Consumer Barometer (2018c), we identified the features that respondents performed on a daily basis via their smartphones. The total number of respondents answering this question was 7 492, the survey was conducted in 2014/2015. The results of this analysis show that although the share of respondents' preferences is different, the most frequently used mobile device features across all V4 countries are the following: alarm clock, taking photos, videos, and making phone calls. 67% of the respondents use the alarm clock in the Czech Republic, 68% in Hungary, 69% in Poland and 70% of the respondents in Slovakia. In all countries, the phone call is more dominant activity than taking photos or videos, with the exception of Hungary. In Hungary, 62% of the respondents use their smartphone to take pictures or record videos, which is one percentage point less respondents than in case of phone calls (61%). On the contrary, the least used smartphone feature is health check across all countries (in the Czech Republic it is 1%), another less frequently used feature is journal management (in Hungary, only 10% of the respondents), in Poland it is reading books (representing 10% and shopping is the step last of this ladder. This feature used via smartphones is least common among the respondents from Slovakia (9%).

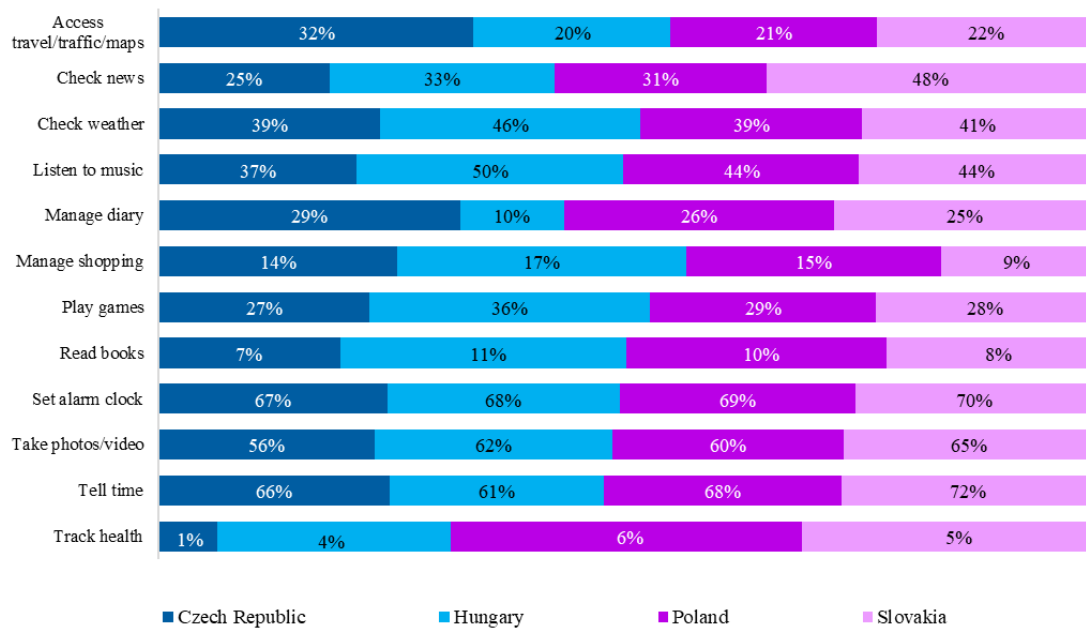
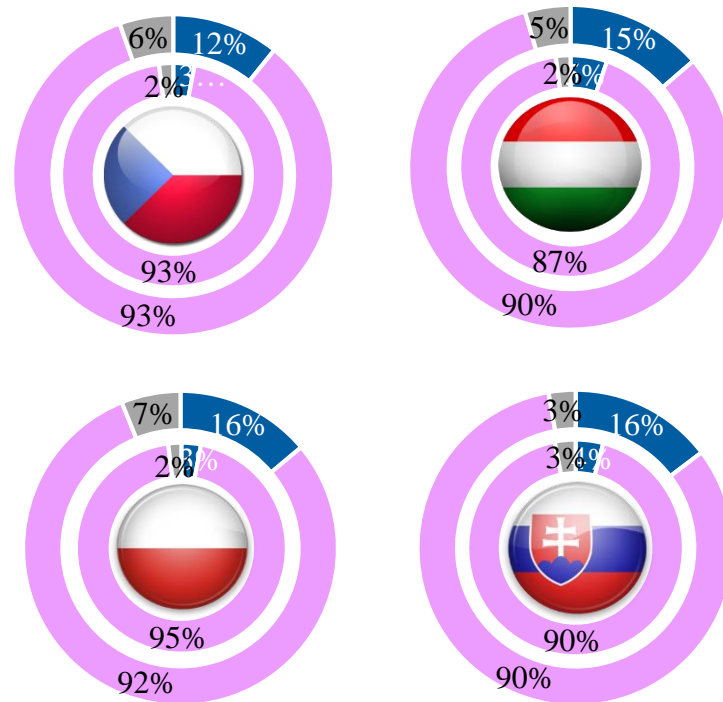

Figure 3: Using smartphone features on a daily basis (Consumer barometer 2018c)

The subject of our analysis of the current state of the selected issue is also the identification of devices through which respondents search for product information and identify the devices through which respondents buy in the online environment. The resulting data was drawn from the available Consumer Barometer portal (2018d). 18 277 respondents answered the question of "Through what devices are you searching for product/service information?" and a total of 10 096 consumers answered the question "Through what devices do you buy products/services in the online environment?" The survey was conducted in 2014/2015. We have interpreted the results of these analyses in Figure 4, from which it is clear that in both cases, when searching for product information and buying products, the most commonly used device (smartphone, computer and tablet) is the computer. The share of respondents searching for information is 90% - 93%, and the proportion of online buyers through computers ranges from 87% to 95%, which makes it clear that computers are still the most dominant device for the V4 country respondents. While in Hungary the share of respondents searching for information (90%) is higher than online buyers (87%), the number of searchers and buyers in the Czech Republic and Slovakia is the same, i.e. in the Czech Republic 93% and in Slovakia 90%. In the case of Poland, however, the situation is the opposite. The share of buyers through computers is higher (95%) than that of respondents searching for product information (93%). The results of the analysis also show that smaller-screen devices such as smartphones and tablets are considerably less preferred devices in the selected V4 countries.

Figure following on the next page



*Outward Circle - Product search*

*Inner Circle - Product buying*

*Figure 4: Share of respondents searching for product/service information and purchasing products/services in an online environment on certain devices (Consumer barometer 2018d1, 2018d2)*

Mobile devices serve not only as a means of purchasing products, but according to the results of analyses, this equipment is currently only used to a very limited extent in the V4 countries, but they have an irreplaceable position at all stages of the entire buying process. Through Consumer Barometer data (2018e), we investigated that in which stages of the buying process consumers use them the most. This survey, carried out in 2014/2015, involved a total of 3506 consumers. Preferences vary from country to country. While in one country consumer preferences are the highest, in the second, the share of respondents is the lowest. In the Czech Republic, the smartphone in the purchasing process is most used to compare offers (41%), but in Hungary the most respondents (37%) use smartphones just before immediate offline purchases. The smartphone in the purchasing process is the most used at the stage when consumers need an advice, according to the respondents from Poland (39%) and Slovakia (27%).

*Figure following on the next page*

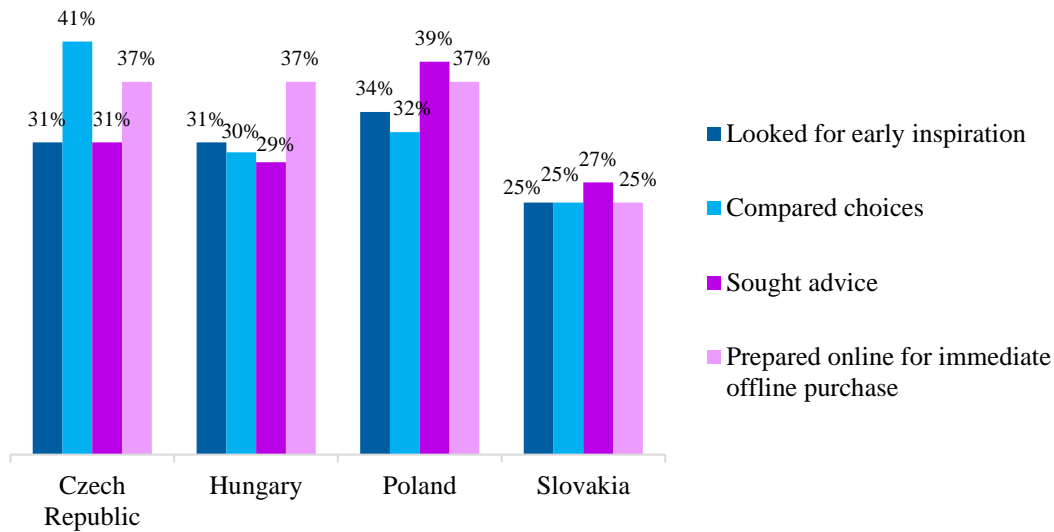

Figure 5: Activities performed through smartphones during the purchasing process (Consumer barometer 2018e)

From the presented results, it can be said that the differences in the monitored countries are noticeable when carrying out various activities through smartphones, but significant differences can not be confirmed. The exception is the use of mobile phones at different stages of the purchasing process, where the differences between the V4 countries were significantly more significant. When searching for product information and product purchases, we can unequivocally confirm that the most dominant device with an incredibly high share across all monitored countries is the computer.

#### 4. CONSLUSION

The untapped technology development, the era of growing digitization and the ubiquity of mobile devices indicate a particularly growing trend in mobile commerce. The fact that receipts from purchases via mobile devices overtake the revenue from purchases made via the desktop is indisputable in the global notion. Advances in technology, logistics and payments, with unlimited access to the Internet or fast penetration of mobile phones and, last but not least, consumer desire for convenience have created a global online shopping platform through which many global consumers are already purchasing anywhere, anytime. However, the present article dealt with consumer buying behaviour within the Visegrad Four countries with a focus on the use of mobile devices in the purchasing process and the analysis has shown that consumers of these countries use a computer rather than a smartphone to buy products in the online environment and it is also used for searching for product information. Mobile devices and integrated technologies serve not only as a means of purchasing products, but also have an irreplaceable position at all stages of the entire purchasing process. From the results of our analysis we can state that the V4 consumers use smartphones at different stages of the purchasing process. For example, Czech respondents when comparing offers, but in Hungary it is used before offline purchases and respondents from Poland and Slovakia use smartphones most often at a stage when they need to buy something. This article deals with the issue of m-commerce in terms of V4 consumer buying habits. The relevant data contained in this article can be useful for those businesses that are trying to improve their access to customer acquisition and retention because the key to a sustainable strategy is the ability to understand and meet customer needs.

**ACKNOWLEDGEMENT:** *This article is one of the partial outputs under the scientific research grant VEGA 1/0806/16 – “Research on issues of consumer behaviour of a new generation of customers with emphasis on identifying preferences and usability of mobile platforms in the process of e-commerce of the subjects localized predominantly on the Central European Market” and VEGA 1/0789/17 – “Research of e-commerce with relation to dominant marketing practices and important characteristics of consumer behaviour while using mobile device platforms.”*

**LITERATURE:**

1. Bačík, R., Gburová, J., Štefko, R. (2015). Impact of the Internet Marketing on the Slovak Consumer. *Central European Conference on Finance and Economics (CEFE)*. Herlany, Slovakia: 30.9. -1.10. 2015, 21-28.
2. Bačík, R., Nastišin, L., Gavurová, B. (2017). The role of social media in the light of building a strong online brand awareness. *5th International Conference Innovation Management, Entrepreneurship and Sustainability (IMES)*. Czech republic, Prague, 25-26.5.2017. pp. 38-47.
3. Beaconstac. (2016). *The State of Indian Mobile Commerce*. Retrieved 25.10.2018 from [https://resources.beaconstac.com/ebook/the-state-of-indian-mobile-commerce.pdf?\\_\\_s=vffvhtrpm9w2gruckzhd](https://resources.beaconstac.com/ebook/the-state-of-indian-mobile-commerce.pdf?__s=vffvhtrpm9w2gruckzhd).
4. Chong, A.Y. (2013). Mobile commerce usage activities: The roles of demographic and motivation variables. *Technological Forecasting and Social Change*, 80(7), 1350-1359.
5. Consumer barometer. (2018a). *Which devices do people use?* Retrieved 27.10.2018 from Available at:  
[https://www.consumerbarometer.com/en/graph-builder/?question=M1&filter=country:slovakia,czech\\_republic,hungary,poland](https://www.consumerbarometer.com/en/graph-builder/?question=M1&filter=country:slovakia,czech_republic,hungary,poland).
6. Consumer barometer. (2018b). *Which online activities are done by people at least as often via a smartphone as computer?* Retrieved 27.10.2018 from  
[https://www.consumerbarometer.com/en/graph-builder/?question=N7&filter=country:slovakia,czech\\_republic,hungary,poland](https://www.consumerbarometer.com/en/graph-builder/?question=N7&filter=country:slovakia,czech_republic,hungary,poland).
7. Consumer barometer. (2018c). *For what daily life activities do people use their smartphone?* Retrieved 27.10.2018 from [https://www.consumerbarometer.com/en/graph-builder/?question=W8&filter=country:slovakia,czech\\_republic,hungary,poland](https://www.consumerbarometer.com/en/graph-builder/?question=W8&filter=country:slovakia,czech_republic,hungary,poland).
8. Consumer barometer. (2018d1). *Which devices did people use for product research?* Retrieved 27.10.2018 from  
[https://www.consumerbarometer.com/en/graph-builder/?question=S33&filter=country:slovakia,czech\\_republic,hungary,poland](https://www.consumerbarometer.com/en/graph-builder/?question=S33&filter=country:slovakia,czech_republic,hungary,poland).
9. Consumer barometer. (2018d2). *Which devices did people use to make their purchase?* Retrieved 27.10.2018 from  
[https://www.consumerbarometer.com/en/graph-builder/?question=S34&filter=country:slovakia,czech\\_republic,hungary,poland](https://www.consumerbarometer.com/en/graph-builder/?question=S34&filter=country:slovakia,czech_republic,hungary,poland).
10. Consumer barometer. (2018e). *In which part(s) of the purchase process did people use a smartphone?* Retrieved 27.10.2018 from [https://www.consumerbarometer.com/en/graph-builder/?question=N10&filter=country:slovakia,czech\\_republic,hungary,poland](https://www.consumerbarometer.com/en/graph-builder/?question=N10&filter=country:slovakia,czech_republic,hungary,poland).
11. Corba, J., Nastišin, L. (2016). Online reputation of companies that have implemented the EMAS III scheme, *International Conference on Engineering Science and Production Management (ESPM)*. Slovakia, 16.-17.4.2015. pp. 45-48.



12. eMarketer. (2018). *Mobile Is Driving Retail Ecommerce Sales Worldwide*. Retrieved 27.10.2018 from:  
[//retail.emarketer.com/article/global-ecommerce-topped-23-trillion-2017-emarketer-estimates/5a6f89f5ebd40008bc791221?ECID=SOC1001&utm\\_content=bufferdfa97&utm\\_medium=social&utm\\_source=twitter.com&utm\\_campaign=buffer](http://retail.emarketer.com/article/global-ecommerce-topped-23-trillion-2017-emarketer-estimates/5a6f89f5ebd40008bc791221?ECID=SOC1001&utm_content=bufferdfa97&utm_medium=social&utm_source=twitter.com&utm_campaign=buffer).
13. Endre, G. (2009). Standardization as open innovation: two cases from the mobile industry. *Information Technology & People*, 22(4), 367-381.
14. Gburová, J., Matušíková, D. (2017). Image of retail and its impact on consumer purchasing decisions. *Education excellence and innovation management through Vision 2020: from regional development sustainability to global economic growth: proceedings of the 29th International Business Information Management Association conference (IBIMA)*: Vienna, Austria: 3.- 4.5. 2017. Norristown: International Business Information Management Association, 3151-3158.
15. Gburová, J., Matušíková, D., Benková, E. (2015). Perception of tourist destination brand. *Ekonomičnyj časopys - XXI = Economic annals – XXI*, 5-6 (2015), 20-23.
16. Groß, M. (2015). Exploring the acceptance of technology for mobile shopping: an empirical investigation among Smartphone users. *The International Review of Retail Distribution and Consumer Research*, 25 (3), 215–235.
17. Hameed, K., Shah, H., Ahsan, K., Yang, W. (2010). An Enterprise Architecture Framework for Mobile Commerce. *International Journal of Computer Science Issues*, 7(4), 6-12.
18. Hung, M.C., Yang, S.T., Hsieh, T.C. (2012). An examination of the determinants of mobile shopping continuance. *International Journal of Electronic Business Management* 10(1), 29-31.
19. Michael, G. (2015). Mobile shopping: a classification framework and literature review. *International Journal of Retail & Distribution Management*, 43(3), 221-241.
20. Mura, L., Zulová, J., Madleňák, A. (2016). Strategic management and management of personnel costs: Employing young people in the Slovak Republic. *Problems and Perspectives in Management*, 14(1), pp. 79-84.
21. Natarajan, T., Balasubramanian, S.A., Kasilingam, D.L. (2018). The moderating role of device type and age of users on the intention to use mobile shopping applications. *Technology in Society*, 53, 79-90.
22. Simon, K. (2015). *Shopping, Productivity and Messaging Give Mobile Another Stunning Growth Year*. Retrieved 27.10.2018 from  
<http://flurrymobile.tumblr.com/post/115194992530/shoppingproductivity-and-messaging-givemobile>, in: F.I. Blog (Ed.) 2015.
23. Štarchoň, P., Lizbetinova, L., Weberová, D. (2016). Clustering in Relation to Brand Perception: An Example Based on Czech Consumers. *Vision 2020: innovation management, development sustainability and competitive economic growth: proceedings of the 28th international business information management association conference (IBIMA)*. Seville, Spain: 9-10.11. 2016. Norristown: International business information management association, 2271-+.
24. Štefko, R., Gburová, J., Matušíková, D. (2016). Analysis of the use of marketing communication in the nonprofit sector in Slovak republic. *Vision 2020: innovation management, development sustainability and competitive economic growth: proceedings of the 28th international business information management association conference (IBIMA)*. Seville, Spain: 9-10.11. 2016. Norristown: International business information management association, 2992-2998.

25. Weberová, D., Štarchoň, P. Lizbetinova, L. (2016). Product Information and its Impact on Consumer Brand Perception. *Vision 2020: innovation management, development sustainability and competitive economic growth: proceedings of the 28th international business information management association conference (IBIMA)*. Seville, Spain: 9-10.11. 2016. Norristown: International business information management association, 1964-1974.
26. Yang, K., et. al. (2012). Mobile shopping motivation: an application of multiple discriminant analysis. *International Journal of Retail & Distribution Management*, 40 (10), 778–798.
27. Zhang, R., Chen, J.Q., Lee, C. (2013). Mobile commerce and consumer privacy concerns. *Journal of Computer Information Systems*, 53(4), 31-38.

## CORPORATE GOVERNANCE IN INDIA: AN ANALYSIS

**Meghna Thapar**

*Hidayatullah National Law University, Raipur, Chhattisgarh, India  
meghathapar6@gmail.com*

### **ABSTRACT**

*Corporate governance is a process, relation and mechanism set up for the corporations and firms based on certain guidelines and principles by which a company is controlled and directed. The principles provided in the system ensure that the company is governed in a way that it is able to set and achieve its goals and objectives in the context of the social, regulatory and market environment, and is able to maximize profits and also benefit those whose interest is involved in it, in the long run. The division and distribution of rights and responsibilities among different participants in the corporation (such as the board of directors, managers, shareholders, creditors, auditors, regulators, and other stakeholders) and inclusion of the rules and procedures for making decisions in corporate affairs are identified with the help of Corporate Governance mechanism and guidelines. The need to make corporate governance in India transparent was felt after the high profile corporate governance failure scams like the stock market scam, the UTI scam, Ketan Parikh scam, Satyam scam, which were severely criticized by the shareholders. Thus, Corporate Governance is not just company administration but more than that and includes monitoring the actions, policies, practices, and decisions of corporations, their agents, and affected stakeholders thereby ensuring fair, efficient and transparent functioning of the corporate management system. By this paper, the authors intend to examine the concept of corporate governance in India with regard to the provisions of corporate governance under the Companies Act 2013. The paper will highlight the importance and need of corporate governance in India. We will also discuss the important case laws which contributed immensely in the emergence of corporate governance in India.*

**Keywords:** *Corporate governance Mechanism, Companies, Firms, Companies Act 2013*

### **1. INTRODUCTION**

Corporate governance defined as "the set of conditions that shapes the ex post bargaining over the quasi-rents generated by a firm."<sup>1</sup> Corporate governance has also been more narrowly defined as "a system of law and sound approaches by which corporations are directed and controlled focusing on the internal and external corporate structures with the intention of monitoring the actions of management and directors and thereby, mitigating agency risks which may stem from the misdeeds of corporate officers."<sup>2</sup> We may infer that Corporate governance is a process, relation and mechanism set up for the corporations and firms based on certain guidelines and principles by which a company is controlled and directed. The principles provided in the system ensure that the company is governed in a way that it is able to set and achieve its goals and objectives in the context of the social, regulatory and market environment, and is able to maximize profits and also benefit those whose interest is involved in it, in the long run. The division and distribution of rights and responsibilities among different participants in the corporation (such as the board of directors, managers, shareholders, creditors, auditors, regulators, and other stakeholders) and inclusion of the rules and procedures for making decisions in corporate affairs are identified with the help of Corporate Governance mechanism and guidelines.

---

<sup>1</sup> Luigi Zingales, 2008. "corporate governance," The New Palgrave Dictionary of Economics, 2nd Edition. Abstract.

<sup>2</sup> Sifuna, Anazett Pacy (2012). "Disclose or Abstain: The Prohibition of Insider Trading on Trial". *Journal of International Banking Law and Regulation*.

The framework of corporate governance consists of:

1. Express or implied contracts between the stakeholders and the company for the distribution of rights, duties, rewards and liabilities, etc among different participants in the corporation.
2. Procedure for proper control and supervision of information flow in the company, i.e., a proper mechanism of checks-and-balances, and
3. Procedures for resolving and reconciling the conflicting interests and decisions of different participants in the corporation.

This mechanism ensures accountability of the Board of Directors to all stakeholders of the corporation i.e. managers, shareholders, suppliers, creditors, auditors, regulators, employees, customers and society in general; for giving the company a fair, clear and efficient administration. So it is not just mere company administration but a corporate management system. It is a code of conduct that must be followed for running and proper functioning of a corporate entity.

## **2. CORPORATE GOVERNANCE FRAMEWORK IN INDIA**

Ever since India's biggest-ever corporate fraud and governance failure unearthed at Satyam Computer Services Limited, the concerns about good Corporate Governance have increased phenomenally. Internationally, there has been a great deal of debate going on for quite some time. The famous Cadbury Committee defined "Corporate Governance" in its Report (Financial Aspects of Corporate Governance, published in 1992) as "the system by which companies are directed and controlled". The Organisation for Economic Cooperation and Development (OECD), which, in 1999, published its Principles of Corporate Governance gives a very comprehensive definition of corporate governance, as under: "a set of relationships between a company's management, its board, its shareholders and other stakeholders. Corporate governance also provides the structure through which the objectives of the company are set, and the means of attaining those objectives and monitoring performance are determined. Good corporate governance should provide proper incentives for the board and management to pursue objectives that are in the interests of the company and shareholders, and should facilitate effective monitoring, thereby encouraging firms to use resources more efficiently."

### **2.1. Regulatory framework on corporate governance**

The Indian statutory framework has, by and large, been in consonance with the international best practices of corporate governance. Broadly speaking, the corporate governance mechanism for companies in India is enumerated in the following enactments/ regulations/ guidelines/ listing agreement:

1. The Companies Act, 2013 inter alia contains provisions relating to board constitution, board meetings, board processes, independent directors, general meetings, audit committees, related party transactions, disclosure requirements in financial statements, etc.
2. Securities and Exchange Board of India (SEBI) Guidelines: SEBI is a regulatory authority having jurisdiction over listed companies and which issues regulations, rules and guidelines to companies to ensure protection of investors.
3. Standard Listing Agreement of Stock Exchanges: For companies whose shares are listed on the stock exchanges.
4. Accounting Standards issued by the Institute of Chartered Accountants of India (ICAI): ICAI is an autonomous body, which issues accounting standards providing guidelines for disclosures of financial information. Section 129 of the New Companies Act inter alia provides that the financial statements shall give a true and fair view of the state of affairs of the company or companies, comply with the accounting standards notified under s 133 of

the New Companies Act. It is further provided that items contained in such financial statements shall be in accordance with the accounting standards.

5. Secretarial Standards issued by the Institute of Company Secretaries of India (ICSI): ICSI is an autonomous body, which issues secretarial standards in terms of the provisions of the New Companies Act. So far, the ICSI has issued Secretarial Standard on "Meetings of the Board of Directors" (SS-1) and Secretarial Standards on "General Meetings" (SS-2). These Secretarial Standards have come into force w.e.f. July 1, 2015. Section 118(10) of the New Companies Act provide that every company (other than one person company) shall observe Secretarial Standards specified as such by the ICSI with respect to general and board meetings.

### **3. CORPORATE GOVERNANCE UNDER THE COMPANIES ACT, 2013**

Many high profile corporate governance failure scams like the stock market scam, the UTI scam, Ketan Parikh scam, Satyam scam, which was severely criticized by the shareholders, called for a need to make corporate governance in India transparent as it greatly affects the development of the country. The Indian Companies Act of 2013 introduced some progressive and transparent processes which benefit stakeholders, directors as well as the management of companies. Investment advisory services and proxy firms provide concise information to the shareholders about these newly introduced processes and regulations, which aim to improve the corporate governance in India. Corporate advisory services are offered by advisory firms to efficiently manage the activities of companies to ensure stability and growth of the business, maintain the reputation and reliability for customers and clients. The top management that consists of the board of directors is responsible for governance. They must have effective control over affairs of the company in the interest of the company and minority shareholders. Corporate governance ensures strict and efficient application of management practices along with legal compliance in the continually changing business scenario in India. Corporate governance was guided by Clause 49 of the Listing Agreement before introduction of the Companies Act of 2013. As per the new provision, SEBI has also approved certain amendments in the Listing Agreement so as to improve the transparency in transactions of listed companies and giving a bigger say to minority stakeholders in influencing the decisions of management. These amendments have become effective from 1st October 2014.

#### **3.1. A Few New Provision for Directors and Shareholders**

- One or more women directors are recommended for certain classes of companies
- Every company in India must have a resident directory
- The maximum permissible directors cannot exceed 15 in a public limited company. If more directors have to be appointed, it can be done only with approval of the shareholders after passing a Special Resolution
- The Independent Directors are a newly introduced concept under the Act. A code of conduct is prescribed and so are other functions and duties
- The Independent directors must attend at least one meeting a year
- Every company must appoint an individual or firm as an auditor. The responsibility of the Audit committee has increased
- Filing and disclosures with the Registrar of Companies has increased
- Top management recognizes the rights of the shareholders and ensures strong co-operation between the company and the stakeholders
- Every company has to make accurate disclosure of financial situations, performance, material matter, ownership and governance

### **3.2. Additional Provisions**

- Related Party Transactions – A Related Party Transaction (RPT) is the transfer of resources or facilities between a company and another specific party. The company devises policies which must be disclosed on the website and in the annual report. All these transactions must be approved by the shareholders by passing a Special Resolution as the Companies Act of 2013. Promoters of the company cannot vote on a resolution for a related party transaction.
- Changes in Clause 35B – The e-voting facility has to be provided to the shareholder for any resolution is a legal binding for the company.
- Corporate Social Responsibility – The company has the responsibility to promote social development in order to return something that is beneficial for the society.
- Whistle Blower Policy – This is a mandatory provision by SEBI which is a vigil mechanism to report the wrong or unethical conduct of any director of the company.

### **4. NEED FOR CORPORATE GOVERNANCE**

The need for corporate governance is highlighted by the following factors:

#### **1. Wide Spread of Shareholders:**

Today a company has a very large number of shareholders spread all over the nation and even the world; and a majority of shareholders being unorganised and having an indifferent attitude towards corporate affairs. The idea of shareholders' democracy remains confined only to the law and the Articles of Association; which requires a practical implementation through a code of conduct of corporate governance.

#### **2. Changing Ownership Structure:**

The pattern of corporate ownership has changed considerably, in the present-day-times; with institutional investors (foreign as well Indian) and mutual funds becoming largest shareholders in large corporate private sector. These investors have become the greatest challenge to corporate managements, forcing the latter to abide by some established code of corporate governance to build up its image in society.

#### **3. Corporate Scams or Scandals:**

Corporate scams (or frauds) in the recent years of the past have shaken public confidence in corporate management. The event of Harshad Mehta scandal, which is perhaps, one biggest scandal, is in the heart and mind of all, connected with corporate shareholding or otherwise being educated and socially conscious. The need for corporate governance is, then, imperative for reviving investors' confidence in the corporate sector towards the economic development of society.

#### **4. Greater Expectations of Society of the Corporate Sector:**

Society of today holds greater expectations of the corporate sector in terms of reasonable price, better quality, pollution control, best utilisation of resources etc. To meet social expectations, there is a need for a code of corporate governance, for the best management of company in economic and social terms.

#### **5. Hostile Take-Overs:**

Hostile take-overs of corporations witnessed in several countries, put a question mark on the efficiency of managements of take-over companies. This factors also points out to the need for corporate governance, in the form of an efficient code of conduct for corporate managements.

6. Huge Increase in Top Management Compensation:

It has been observed in both developing and developed economies that there has been a great increase in the monetary payments (compensation) packages of top level corporate executives. There is no justification for exorbitant payments to top ranking managers, out of corporate funds, which are a property of shareholders and society. This factor necessitates corporate governance to contain the ill-practices of top managements of companies.

7. Globalisation:

Desire of more and more Indian companies to get listed on international stock exchanges also focuses on a need for corporate governance. In fact, corporate governance has become a buzzword in the corporate sector. There is no doubt that international capital market recognises only companies well-managed according to standard codes of corporate governance.

## **5. IMPORTANCE OF CORPORATE GOVERNANCE IN INDIA / CONCLUSION**

A company that has good corporate governance has a much higher level of confidence amongst the shareholders associated with that company. Active and independent directors contribute towards a positive outlook of the company in the financial market, positively influencing share prices. Corporate Governance is one of the important criteria for foreign institutional investors to decide on which company to invest in. The corporate practices in India emphasize the functions of audit and finances that have legal, moral and ethical implications for the business and its impact on the shareholders. The Indian Companies Act of 2013 introduced innovative measures to appropriately balance legislative and regulatory reforms for the growth of the enterprise and to increase foreign investment, keeping in mind international practices. The rules and regulations are measures that increase the involvement of the shareholders in decision making and introduce transparency in corporate governance, which ultimately safeguards the interest of the society and shareholders. Corporate governance safeguards not only the management but the interests of the stakeholders as well and fosters the economic progress of India in the roaring economies of the world.

### **LITERATURE:**

1. Asish K. Bhattacharyya, 'Corporate Governance in India: Change and Continuity', Oxford University Press (19 September 2016).
2. Das S. C., Corporate Governance in India: An evaluation, Taxmann; 2015 edition (2016).
3. Fernando, 'Business Ethics and Corporate Governance', Pearson Education India; 2 edition (2012).
4. Indian Institute of Corporate Affairs, "Corporate Governance", Taxmann; 2015 edition (2016).
5. Prasad K, 'Corporate Governance', Prentice Hall India Learning Private Limited; 2 edition (2011).
6. T. N. Satheesh Kumar, 'Corporate Governance: Principles and Practices', Pearson Education India; 4 edition (2011).
7. Tricker, 'Corporate Governance: Principles, Policies and Practices', Oxford University Press India; Second edition (14 January 2013).

# ANALYSIS OF INVESTOR BEHAVIOR: MARKET FEELING AND HERDING BEHAVIOR IN THE PORTUGUESE STOCK MARKET

**Gabriela Leite**

*Porto Lusófona University, Porto, Portugal  
gabriela\_leite@sapo.pt*

**Humberto Ribeiro**

*GOVCOPP, ESTGA, University of Aveiro, Aveiro, Portugal  
hnr@ua.pt*

**Carlos Machado-Santos**

*UTAD University, Vila Real, Portugal  
cmsantos@utad.pt*

**Amelia Ferreira da Silva**

*CEOS of Polytechnic of Porto,  
Porto Accounting and Business School, Porto, Portugal  
acfs@iscap.ipp.pt*

**Jose Manuel Pereira**

*ESG, IPCA-Polytechnic Institute of Cávado and Ave, Barcelos, Portugal  
jpereira@ipca.pt*

## ABSTRACT

*This paper aims to analyze the behavior of investors in the Portuguese capital stock market, in particular while studying the relationship between the herding behavior phenomenon and the market sentiment. The results obtained allow observing the existence of a significant level of herding behaviour intensity, especially when there is price variation occurrence. On the other hand, when herding is related to market sentiment, the statistical evidence allows one to conclude that herding behavior is encouraged when investors are attentive to the expectations of other market participants, suggesting that the emotional condition inherent of market capitalism is decisive in explaining the phenomenon of herding behavior.*

**Keywords:** *Herding Behavior, Market Sentiment, Behavioral Finance, Capital Markets, Portuguese Stock Market, PSI-20*

## 1. INTRODUCTION

Nowadays, perhaps more than ever before, capital markets are characterized by such dynamism that they challenge the soundness of the financial system itself and the regulatory and supervisory mechanisms. Globalization, the rapid development of information technologies and the creation of the euro are just some of the drivers of the growing integration of financial markets. The behavioral approach to finance has been gaining ground to the classical theory of market efficiency, the latter's inability to explain a series of financial events (e.g., herding behavior, noise trading, positive-feedback trading) and therefore limiting themselves to classifying them as "market anomalies". However, the occurrence of such anomalies derives essentially from a factor that until a few years ago was not considered as explanatory of such phenomena - the behavior of the investors. Indeed, despite the indisputable merit of the classical theory of market efficiency, the truth is that emotions have assumed a decisive role in decision making (Salzman & Trifan, 2005). The objective of this study is to analyze the behavior of investors, in the particular case of the Portuguese capital market, between 1998 and 2010.



For this purpose, the intensity of herding present in the market is determined and the relationship between this phenomenon and the market sentiment.

## **2. THE HERDING BEHAVIOR PHENOMENON**

The financial literature has come a long way, from the days when the market efficiency hypothesis was accepted irrefutably. Despite recognizing the unrealism of some assumptions, the consistency of the model to explain the functioning of the capital market has not been questioned for many years. In fact, the hypothesis of market efficiency has become one of the main foundations of financial theory, with countless studies that for decades have allowed the assumption of efficient markets (Fama, 1970, Van Horne, 1995). Financial theory seeks to explain the financial commitment and real investment behavior that emerges from the interaction between managers and investors. So a full explanation of funding and investment patterns requires an understanding of the beliefs and preferences of these two types of agents. Most business finance research assumes the assumption of rationality. They assume that agents develop unbiased predictions about future events and use them to make the decisions that best suit their own interests. In practice this means that managers can be assured the efficiency of the capital market, with prices reflecting public information about the real value of the asset. In turn, investors can assume that managers will act in their own interests, rationally responding to incentives formed by compensation contracts, the business control market and other government mechanisms. Effectively, self-interest and decision-maker preferences are the cornerstones of rational choice theory. In the decision-making process, the individual tends to decide to maximize his or her self-interest, so the choices made are, in themselves, revealing their preferences. In this sense, the rational model considers that the decision maker has the possibility not only to estimate the consequences of the decision but also to assign exact values to the importance of each of these consequences (Ferreira et al., 2001). However, the theory of limited rationality emerges as a first critical response to the principle of maximization postulated by the rational model, opening the way to ponder factors such as risk and uncertainty in decision making. More recently, the behavioral approach in the analysis of investment strategies has questioned many of the assumptions made by the market efficiency hypothesis, giving more and more importance to sociological and psychological factors in explaining the functioning of capital markets, suggesting that emotions and (2003), and in the case of investors' perceptions of investor sentiment (Bazerman, 2002, Camerer, 2003 and Locke & Mann, 2003, Scheinkman & Xiong, 2003, Thaler & Barberis, 2003, Fehr & Fischbacher 2003, Salzman & Trifan, 2005). For Lintner (1998) behavioral finance studies how investors interpret information, and act accordingly, in making investment decisions. In turn, Olsen (1998) argues that behavioral finance does not attempt to define the rationality of behavior, but rather to understand and anticipate the psychological decision processes that are felt in financial markets. In this sense, Thaler (1999) argues that, often to find a solution to an empirical problem, it is necessary to consider the possibility that some investors do not behave at all times in a completely rational way. Fromlet (2001) points out that behavioral finance studies the rationality of investors and the implications of cognitive processes in making investment decisions. New research in the area of neuroeconomics, which uses methods of neuroscience and economics, allow a better understanding of decisions taken in an economic and social context. Economists assume that an individual will condition his action on the basis of what he believes to be the actions of other individuals. Hence, within a variety of possible actions, he will opt for the one that seems most appropriate to that of the other individuals. Neuroeconomics provides the basis for beliefs, preferences and behavior. Although intuitively investors have the notion that psychological convictions can influence both the asset value and the transaction activity itself, few studies can empirically establish this relationship. In fact, it is undeniable that more and more studies suggest that investor sentiment has an impact on the price of the

assets transacted by them. However, the literature is little consensual in what concerns the definition of these same feelings. The phenomenon of herding behavior results from the mental activity of individuals as an impulse to respond to the behavior of others. Since it is no more than a strategy of effective imitation, at the same moment in time, it can be said that herding behavior is an immediate reaction to perceptions related to feelings and therefore is thoughtless and impulsive (Pretcher, 2001). There are several studies that propose a variety of measures and indicators to prove the existence of the herding behavior phenomenon, among which Wermers (1999), Chang et al. (2000), Hwang & Salmon (2004), Sias (2004), Patterson & Sharma (2006). In fact, although arguments about the existence of herding behavior are numerous and conclusive and market observers themselves record their occurrence, empirical evidence is scarce and in relatively few cases its existence is confirmed (Blasco et al., 2007). Pretcher (2001) argues that herding behavior, as appropriate behavior in some primitive and somewhat dramatic situations of personal life, proves to be not only inappropriate but also counterproductive when the aim is to achieve success in financial situations. The unconscious impulses, developed in order to realize positive values and avoid negative values, stimulate the phenomenon of herding behavior, greatly hindering the rational independence in this group of investors. Negative feedback develops because stress increases impulsive mental activity, and this in financial situations, causing collapse, increases one's stress. Wall Street certainly will have aspects similar to those of a multitude and there is some empirical evidence that the phenomenon of herding behavior is characteristic of many market participants, whether they are institutional investors or simply individual investors (Pretcher, 2001). In fact, when the crowd is in charge, even rational investors end up letting themselves be driven by the prevailing impulses and emotions in that group, to the detriment of their own rationality and convictions. Herding behavior is counterproductive to success in a world characterized by financial speculation. If a given capital market is up or down, the limbic system immediately produces emotions that support the impulses of euphoria, hope, prudence or, in the limit, panic. Nothing more than opposite reactions to success, which is why a lot of investors suffer losses when they speculate. In a large number of situations, the hope and behavior of herding may lead to well-being, but not in the capital market.

### **3. METHODOLOGY AND DATABASE**

#### **3.1. Database construction and description**

In order to assess the intensity of herding in the Portuguese capital market, a daily database was constructed, considering, for this purpose, the maximum, minimum, opening and closing prices. In the first phase, the analysis focuses on the market index - Portuguese Stock Index 20 (PSI-20). However, it is considered of interest to apply similar tests to the stocks underlying the PSI-20 index, in order to allow a comparison of the results, so that, whenever it is possible to adapt the methodology, additional tests are performed to the underlying stocks of the index. The time span chosen is 144 months (12 years) between July 1998 and June 2010. The data are processed on a daily basis and over a sufficiently long time period so that the results are not distorted by any anomalous occurrences, or of a purely extraordinary nature, on the capital market.

#### **3.2. Measurement of herding intensity**

The methodology adopted is according to Blasco et al. (2007, 2009), with the herding intensity estimated according to Patterson & Sharma (2006), measured both in sequences initiated by the buyer and by the seller. Based on the information cascade model of Bikhchandani et al. (1992), Patterson & Sharma (2006) report that an information cascade is observed when there are negotiation sequences initiated by the buyer or seller that are larger than the trading sequences that would be observed if each investor decided only on the basis of the information he had.

The measure of herding intensity proposed by Patterson & Sharma (2006) varies according to the sequence contrasts. Thus, if investors mimic in a systematic way, the values of the statistical indicator should be negative and significant, because the actual number of sequences started is lower than expected:

$$x(i, j, t) = \frac{(r_i + 1/2) - np_i(1 - p_i)}{\sqrt{n}} \quad (1)$$

where:

- $r_i$ : actual number of sequences of type i (high, low or neutral);
- $n$ : total number of transactions carried out on asset j and on day t;
- 1/2: discontinuous adjustment parameter;
- $p_i$ : probability of finding a sequence of type i.

In asymptotic conditions, the statistic  $x(i, j, t)$  follows a normal distribution of zero mean and variance

$$\sigma^2(i, j, t) = p_i(1 - p_i) - 3p_i^2(1 - p_i)^2 \quad (2)$$

To estimate the intensity of the herding present in the market, the type of daily sequences for each title begins to be identified. In this sense, the daily yield of each bond is determined and it is assumed that it is a (high), b (low) or n (neutral) type when the yield of the bond is positive, negative or zero, respectively. The daily profitability of company stock j on day t is calculated arithmetically, according to equation (3):

$$profitability_{j,t} = \frac{PF_{j,t} - PF_{j,t-1}}{PF_{j,t-1}} \quad (3)$$

where:

- $PF_{j,t}$ : the closing price of the shares of company j on day t;
- $PF_{j,t-1}$ : the closing price of the company's shares j on day t-1.

In this sense, each day the shares traded in the market are grouped into three types that reflect whether the transaction is initiated by a buyer, a seller or neutral. In this way, the shares are distributed according to the type of sequence, obtaining daily series of shares traded up (type a), down (type b) or neutral (type n). On a daily basis, and for each of the three types of trading that exhibit if the sequence is initiated by a buyer, by a seller or neutral, the mean value of the transverse series must be calculated, thus obtaining a time series of values average. Thus, Patterson & Sharma (2006) define the measure of herding intensity through the following statistics:

$$H(i, j, t) = \frac{x(i, j, t)}{\sqrt{\sigma^2(j, t)}} \xrightarrow{a.d} N(0,1) \quad (4)$$

The variable i assumes three different values, depending on the types of transaction mentioned above, in order to obtain three statistical series of herding, namely:

- $Ha$ : series of statistical values in high sequences (buyer);
- $Hb$ : series of statistical values in low sequences (seller);
- $Hn$ : series of statistical values in sequences without price change (zero tick).

Thus, the statistics  $Ha$ ,  $Hb$  and  $Hn$  are obtained for each day and for all securities underlying the market index. Finally, the mean, median, standard deviation, skewness, kurtosis, the maximum and minimum values of the series are calculated. In this way, conclusions can be drawn on the daily series of herding intensity measurements in high, low or neutral sequences.

### 3.3. Market sentiment and herding

Patterson & Sharma (2006) seek to deepen the study of herding behavior by analyzing the effects of market sentiment on this phenomenon. Market sentiment, as a potentially conditioning factor of asset return, allows us to define the "emotional" state of the capital market. There are several factors that contribute to market sentiment, highlighting available information, expert opinion, government decisions and the effect of contagion between markets. In this sense, associated with the market sentiment, are the concepts of bull market and bear market when optimism or pessimism, respectively, dominate the market. Since the market sentiment is used to explain the synchronized behavior of investor groups, then when the size of these groups increases, it may be faced with the herding behavior phenomenon.

Through regressions (5) and (6) we analyze the causal relationship between market sentiment and herding, trying to study, on the one hand, the extent to which market sentiment positively influences herding and, on the other hand, what is the impact of the intensity of the herding on the market sentiment.

$$H_{i,t} = \alpha_1 + \sum_{j=1}^n \beta_j H_{i,t-j} + \sum_{j=1}^n \delta_j S_{t-j} + \varepsilon_{t1} \quad (5)$$

$$S_t = \alpha_2 + \sum_{j=1}^n \phi_j H_{i,t-j} + \sum_{j=1}^n \gamma_j S_{t-j} + \varepsilon_{t2} \quad (6)$$

where:

$H_{i,t}$ : herding intensity measure, described in equations (1), (2) and (4);

$S_t$ : market sentiment indicator;

$\varepsilon_{t1}$ ,  $\varepsilon_{t2}$ : regression residuals;

$\alpha_1$ ,  $\alpha_2$ ,  $\beta_j$ ,  $\delta_j$ ,  $\phi_j$ ,  $\gamma_j$ : model parameters.

A final note, to mention that authors such as Hwang & Salmon (2005), Uchida & Nakagawa (2007) and Hsieh et al. (2008) relate the market sentiment to the imitation effect in the markets, assuming the existence of a relationship between the two. In these studies, the conclusions point in the sense that one can find more herding behavior in the market when the expectations about the market (feeling) are more homogeneous.

## 4. EMPIRICAL ANALYSIS

### 4.1. Measurement of herding intensity in the Portuguese Stock Market

In order to determine the intensity of herding in the Portuguese capital market, the methodology of Paterson & Sharma (2006), as described in section 2.2, is applied. In this sense, the daily yield of the underlying stocks is calculated, grouped by type a, b or n - depending on the yield obtained being positive, negative or zero, respectively. This procedure allows to identify the actual number of sequences by type, as well as the total number of daily transactions per action and, therefore, to perform the calculations proposed in equation (3). Then, after calculating the mean value of the transverse series and the consequent obtaining of the time series of mean

values, it is possible to measure the statistical series in high (Ha), low (Hb) and neutral (Hn) sequences, according to equation 4). Table 1 presents the descriptive values of the herding intensity measure, in high, low or neutral sequences, occurring in the stocks underlying the market index, for the period from July 1998 to June 2010. In the last two lines, (as well as their associated probability) for the null hypothesis of the equality of the means between the series.

*Table 1: Measurement of herding intensity*

	<i>Ha</i>	<i>Hb</i>	<i>Hn</i>
<i>Mean</i>	-1,0656	-1,0545	-0,9599
<i>Median</i>	-1,0630	-1,6295	-1,0318
<i>Maximum</i>	0,0000	2,2960	0,3896
<i>Minimum</i>	-2,4900	-2,4904	-1,8991
<i>Sta.Dev.</i>	0,2522	0,3305	0,3829
<i>Skewness</i>	1,1818	4,4086	1,4270
<i>Kurtosis</i>	8,3942	37,6249	4,7659
		<i>Anova</i>	
<i>F-stat</i>		96,2961	
<i>p-value</i>		0,0000	

Based on the statistical evidence, it is possible to reject the null hypothesis of equality of means, concluding, with a confidence level of 99% (p-value tends to zero), that the mean of the time series Ha, Hb and Hn differs between the herding intensity sequences. In this way, the results show that, on average, the herding intensity is negative and significant in both high, low and neutral sequences, with a higher herding intensity when prices change (and, of course, profitability) than in the unvarying (or no-return) sequences. Effectively, although in the neutral sequence the herding intensity is significant (-0.9599) is lower than in the high (-1.0656) or low (-1.0545) sequences. Furthermore, in the low sequence the values of skewness and kurtosis are quite high, which indicates a leptokurtic distribution, the right tail being heavier than in any of the other sequences (Ha and Hn). Such evidence may be the result of the high and asymmetrical market volatility, especially when the sequences are initiated by the seller. It should be noted that in all sequences skewness has positive values, which is a reflection of the higher probability of gain, regardless of whether it is a sequence initiated by the buyer, the seller or neutral. The results allow to conclude that the intensity of the herding is more evident in the sequences initiated by the buyer or the seller, in which there is increase or decrease of the price, respectively. However, the herding phenomenon also occurs in actions that do not change price (neutral sequences), but with less intensity. These conclusions are consistent with the fact that the purchase and / or sale of assets gives the market a signal of increase and / or decrease in price. In this sense, it is expected that price increases will be followed by further increases and decreases in price to be followed by further decreases. In short, in the Portuguese capital market, between July 1998 and June 2010, investors tend to imitate each other systematically, especially when there is price variation due to the purchase and / or sale of assets. herding behavior is more pronounced. The results obtained for the Portuguese market are consistent with those of Blasco et al. (2007) who find high levels of herding intensity in the Spanish capital market.

It should be recalled that the actions analyzed are those underlying the PSI-20, that is, the actions of the companies that reveal the size and liquidity appropriate to the market representation. This means that the index will include the stocks with the highest level of liquidity, on the one hand, and with greater market capitalization, on the other. Thus, the results obtained may be consistent with authors such as Farrar & Girton (1981) and Del Guercio (1996) who point out that investors tend to focus on large companies and therefore adjust their portfolios to the market index. On the other hand, it may also be understood, however implicitly, that glamor stocks constitute a market share attractive to investors, as advocated by authors such as Black (1976), Froot et al. (1992) and Hirshleifer et al. (1994), among others.

#### 4.2. Market sentiment and herding in the Portuguese Stock Market

The results of the relationship between the intensity of herding and the market sentiment, estimated according to equation (5), are presented below in table 2. Due to the impossibility of adapting the methodology to the actions underlying the index, this procedure is only applied to PSI-20.

*Table 2: Results of herding intensity measurement (PSI-20)*

		$H_{a,t}$	$H_{b,t}$	$H_{n,t}$
$H_{i,t-j}$	<i>t-stat</i>	3,8358	4,9883	9,3239
	<i>p-value</i>	0,0002*	0,0000*	0,0000*
$S_{t-j}$	<i>t-stat</i>	2,2685	2,4428	3,5453
	<i>p-value</i>	0,0248**	0,0158**	0,0005*

\* 1% significance level; \*\* 5% significance level

The results obtained allow to conclude, with 95% confidence, that the market sentiment explains the intensity of the herding in both sequences initiated by the buyer and by the seller. Likewise, with 99% confidence, market sentiment is statistically significant in explaining herding in neutral sequences. On the other hand, the estimates obtained lead to conclude, with 99% confidence, that the herding intensity in the previous period conditions the herding in the current period. Regarding the study of the relationship between herding and market sentiment, the results of the coefficients show that these are not statistically significant in explaining the dependent variable. Effectively, none of the parameters is statistically significant in relation to the estimates found, so the hypothesis of nullity of the parameters is not rejected, as can be observed from table 3 below.

*Table following on the next page*

Table 3: Results of the measure of market sentiment (PSI-20)

		$S_t$
$H_{a,t-j}$	<i>t-stat</i>	-0,4809
	<i>p-value</i>	0,6314
$S_{t-j}$	<i>t-stat</i>	0,8921
	<i>p-value</i>	0,3739
$H_{b,t-j}$	<i>t-stat</i>	-0,4185
	<i>p-value</i>	0,6762
$S_{t-j}$	<i>t-stat</i>	-0,3211
	<i>p-value</i>	0,7486
$H_{n,t-j}$	<i>t-stat</i>	-0,3211
	<i>p-value</i>	0,7486
$S_{t-j}$	<i>t-stat</i>	0,8348
	<i>p-value</i>	0,4053

In short, there is no statistical evidence to find a causal relationship between herding and market sentiment. Moreover, past market sentiment does not condition market sentiment in the current period, which seems to indicate that the investor has a "short memory." However, the results obtained seem to indicate that the market sentiment in Portugal explains the intensity of the herding in the analyzed sequences (high, low and neutral). These conclusions are in agreement with Shiller (1984), Bikchandani (1992), Hirshleifer & Welch (1992) and Subrahmanyam & Titman (1994) who point out that herding behavior can be explained by investors transacting on the basis of the same information and signals provided by the market. Since market sentiment is a reflection of investors' expectations, it is understandable that the "emotional state" in the market is directly related to investor behavior, particularly with herding behavior.

## 5. CONCLUSION

The behavioral approach to finance has played a key role in explaining the functioning of the capital market. Admitting that investors' behavior may have a direct impact on the price of assets, influencing the market's own volatility, constitutes a "giant step" in the financial area. Effectively, from the theory of market efficiency to behavioral finance, a long way has gone by. The present work sought to analyze the behavior of investors, especially through the study of herding behavior and its relationship with market sentiment. A first conclusion to be drawn is that the results show that for stocks included in the market index, investors tend to imitate each other in a systematic way, which is in line with, for example, the results obtained by Blasco et al. (2007). Effectively, it is verified the predominance of high levels of herding intensity in the transaction of the shares underlying the PSI-20, especially in the sequences initiated by the buyer or seller, that is, when there is price variation. When one looks at how market sentiment (understood as the "emotional state" of the capital market) is related to herding, the results seem consistent with the fact that herding behavior is all the more encouraged when investors are more attentive the expectations of the other market participants and the signals that their transactions transmit to the market.

The results obtained are in accordance with Shiller (1984) and Hirshleifer et al. (1994), who point out that investors are transacting on the basis of the same information and interpreting market signals in a similar manner as an explanatory cause.

#### **LITERATURE:**

1. Bazerman, M.H. (2002). *Judgement in managerial decision making*. 5th ed. New York: Willey.
2. Bikhchandani, S. (1992). A Bargaining Model with Incomplete Information. *Review of Economic Studies* 59 (1): 187-203
3. Bikhchandani, S.; Hirshleifer, D.; Welch, I. (1992). A theory of fads, fashion, custom, and cultural change as informational cascades. *Journal of Political Economy* 100: 992-1096.
4. Black, F. (1976). The dividend puzzle. *Journal of Portfolio Management* 2: 5-8.
5. Blasco, N.H.; Corredor, C.P.; Ferruela, G.S. (2007). Caracterizando el herding. Una explicación desde el Mercado de derivados. Working paper. Universidad Publica de Navarra. DT 88/07.
6. Blasco, N.H.; Corredor, C.P.; Ferruela, G.S. (2007a). Sentimiento de Mercado y herding. Working paper. Universidad Publica de Navarra.
7. Blasco, N.H.; Corredor, C.P.; Ferruela, G.S. (2009). The implications of herding on volatility. The case of the Spanish stock market. Working paper. Universidad Publica de Navarra. DT 98/09.
8. Camerer, C.F. (2003). *Behavioral game theory – experiments in strategic interaction*. Princeton. New York. Princeton University Press.
9. Chang, E.C.; Cheng, J.W.; Khorana, A. (2000). An examination of herd behavior in equity markets: an international perspective. *Journal of Banking and Finance* 24: 1651-1679.
10. Del Guercio, D. (1996). The distorting effect of the prudent-man laws on institutional equity investments. *Journal of Financial Economics* 40: 31-62.
11. Fama, E.F. (1970). Efficient capital markets: a review of theory and empirical work. *Journal of Finance* 25: 383-417.
12. Farrar, D.; Girton, L. (1981). Institutional investors and concentrations of financial power: berle and means revisited. *Journal of Finance* 36: 369-381.
13. Fehr, E.; Fischbacher, U. (2003). The nature of human altruism. *Nature* 2003 425 (6960): 785-791.
14. Fehr, E.; Fischbacher, U.; Kosfeld, M. (2005). Neuroeconomic foundations of trust and social preferences: initial evidence. *Neuroscientific foundations of economic decision-making. AEA papers and proceedings* 2 (95): 346-351.
15. Ferreira, J.M.C.; Neves, J.; Caetano, A. (2001). *Manual de psicossociologia das organizações*. McGraw-Hill.
16. Fromlet, H. (2001). Behavioral finance – theory and practical applications. *Business economics* 36: 63-69.
17. Froot, K.A.; Scharfstein, D.S.; Stein, J.C. (1992). Herd on the street: informational inefficiencies in a market with short-term speculation. *Journal of Finance* 47: 1461-1484.
18. Hirshleifer, D.; Subrahmanyam, A.; Titman, S. (1994). Security analysis and trading patterns when some investors receive information before others. *Journal of Finance* 49: 1665-1698.
19. Hsieh, S.; Tai, Y.Y.; Vu, T.B. (2008). Do herding behavior and positive feedback effects influence capital inflows? Evidence from Asia and Latin America. *The International Journal of Business and Finance Research* 2 (2): 19-34.
20. Hwang, S.; Salmon, M. (2004). Market stress and herding. *Journal of Empirical Finance* 11: 585-616.



21. Hwang, S.; Salmon, M. (2005). Measuring herding and sentiment in financial markets. Working paper.
22. Lintner, G. (1998). Behavioral finance: Why investors make bad decisions. *The Planner* 13 (1): 7-8.
23. Lock, P.R.; Mann, S.C. (2003). Professional trader discipline and trade disposition. Working paper. Texas Christian University.
24. Olsen, R. (1998). Behavioral finance and its implications for stock price volatility. *Financial Analysts Journal* 54 (2): 10-18.
25. Patterson, D.M.; Sharma, V. (2006). Do traders follow each other at the NYSE? Working paper, disponível em SSRN (<http://ssrn.com/abstract=712401>).
26. Prechter, R.R. (2001). Unconscious herding behavior as the psychological basis of financial market trends and patterns. *The Journal of Psychology and Financial Markets* 2 (3): 120-125.
27. Ross, S.; Westerfield, R.; Jaffe, J. (1995). *Administração Financeira*. Atlas.
28. Salzman, D.; Trifan, E. (2005). Emotions, bayesian inference, and financial decisions making. Publications of Darmstadt Technical University. Department of Business Administration, Economics and Law. Institute of Economics (VWL).
29. Scheinkman, J.A; Xiong, W. (2003). Overconfidence and sprculative bubbles. *Journal of Political Economy* 111 (6): 1183-1219.
30. Shiller, R.J. (1984). Stock prices and social dynamics. *Brooking Papers* 2: 457-510.
31. Sias, R.W. (2004). Institutional herding. *Review of Financial Studies* 17 (1): 165-206.
32. Thaler, R. (1999). The end of behavioral finance. *Financial Analysts Journal* 55 (6): 12-17.
33. Thaler, R.; Barberis, N. (2003). A survey of behavioral finance in Constantinides, G.; Harriz, M.; Stulz R. (Eds.). *Handbook of the Economics of Finance*. New York. North-Holland.
34. Uchida, H.; Nakagawa, R. (2007). Herd behavior in the Japanese loan market: evidence from the bank panel data. *Journal of Financial Intermediation* 16 (4): 555-583.
35. Van Horne, J.C. (1995). *Financial management and policy*. 10.<sup>a</sup> ed. New Jersey. Prentice-Hall.
36. Wermers, R. (1999). Mutual fund herding and the impact sock prices. *Journal of Finance* 54: 581-622.

## ONLINE SHOPS AND ONLINE SHOPPING FROM THE POINT OF VIEW OF THE SLOVAK CONSUMER

**Jaroslava Gburova**

*University of Prešov in Prešov, Faculty of Management, Slovakia  
jaroslava.gburova@unipo.sk*

**Richard Fedorko**

*University of Prešov in Prešov, Faculty of Management, Slovakia  
richard.fedorko@unipo.sk*

### **ABSTRACT**

*Nowadays, Internet and information technologies have become a daily part of life for billions of people around the world, as they allow a rapid exchange of information. Online shopping has gained more and more profit in recent years, both on the Slovak and foreign markets. The Internet has a huge impact on the consumer's final decision when making a purchasing decision. This phenomenon is a colossal source of information that greatly affects the shopping behaviour and consumer decision-making. Consumers are very well informed about products or services about the prices, quality and reviews. The objective of the paper is the theoretical processing of the researched problems in the field of internet marketing and online shopping, as well as the analysis of the influence of purchase on the examined consumers and the discovery of the differences in internet shopping from the point of view of the Slovak consumer.*  
**Keywords:** *Internet, Consumer, Price, Online Purchase, Internet Advertising*

### **1. INTRODUCTION**

Marketing is based on customer relationships. It means a conscious, market-oriented management of a company and an organization where the customer is, to some extent, alpha and omega of the business process. If a company wants to survive in a market environment, it must regularly take care of customer behaviour and to attract the final consumers. A satisfied customer is especially important for the future of the company (Jakubíková, 2008). New technologies lead companies to creative thinking. The role of marketing communication is to make it easier for potential customers to make decisions, in particular by allowing them to use the experience of their own or someone who has their trust. The concept of experienced marketing pushes the importance of marketing communication into a new dimension. All business activities need to be linked to the communication task: allow the customer to test the product and let him decide (Příkrylová, Jahodová, 2010). Businesses are currently moving to the Internet. Companies invest in information technology and e-commerce to increase efficiency of operations and improve customer service. In order to say that everything is done through the Internet, the letter 'e' (as electronic) is inserted before the common word. For example, the word e-business (e-business) or e-business, which we usually understand as a wider concept than e-commerce or e-commerce (Blažková, 2005). The 'everything is on the web' saying has become increasingly truthful. Users use their duties as well as entertainment from the real world to move to the Internet, such as shopping, communication or financial operations. People are using the computers and the Internet more and more often. The marketing and promotional activities of the media started to follow the trend in order to adapt to the behaviour of their target groups and thus penetrate the Internet (Rajčáková, 2009).

### **2. LITERATURE REVIEW**

E-commerce has become a standard and is a very good alternative for implementing business activities between different types of subjects.

E-commerce covers areas ranging from distribution, purchasing, sales, marketing to product servicing, while data communication is implemented through electronic systems (Suchánek, 2012). According to Jandoš (2001) e-commerce is an integration of processes, applications and systems. The objective is to meet changing customer requirements by offering something new. Such trading involves only the purchase and sale of goods and services using ICT. Online shopping is associated with the boom of the internet. In the early 1990s, the company used the Internet to promote and establish customer contact. In particular, it was the location of product presentations, business information, contacts, manuals and etc. In 1994, the first online stores that we are familiar with began to emerge. Companies have slowly begun to realize that the Internet is a new medium made available to millions of people around the world. An essential feature of the development of e-shopping was encryption that ensures the transfer of credit card data. Since then, server technologies have been developed to create e-shops with thousands of products. The bigger the offer of products on the Internet, the higher the traffic is on the internet portals (Vávrová, 2011; Hesková, Štarchoň, 2009). Although, Amazon and eBay, the internet giants influenced the market and adapted the idea that the merchandise can be viewed online not only for looking but also for buying. Both pages represent two basic types of business approach where the Internet will excel: selling a wide range of goods and a large unified market for second hand goods. The huge success of these companies also expressly denounces the dominance of large brands in the world of e-commerce (Chatfield, 2013; Bačík et al., 2015). Simplified, we can say that e-business is just an electronic form of already existing activities. As in the past, consumers have received product brochures in paper form, an electronic presentation is preferred in electronic commerce (Pollák et al., 2015), through websites, e-mail, and etc. Similarly, cash transactions are being executed electronically, e.g. paying by credit cards, using electronic checks, or direct payments from a bank account on the Internet (e.g. e-pay). In terms of definition, the business organization includes both profitable and non-profit entities. Their processes include production, customer, internal, or business-oriented business processes (Delina, Vajda, 2008; Štefko et al., 2015; Lelková, Lorincová, 2015). E-commerce and e-business may look the same, but they are different concepts. According to Manzoor (2010) they have several common characteristics:

- providing greater benefits in the form of more efficient practices,
- reducing costs and generates potential higher profits,
- using technology infrastructure of databases, application servers, security tools and system management,
- involving the creation of new value chains between the company and its customers and suppliers, as well as within the company,
- including significant and potentially disruptive organizational changes.

The results in Figure 1, according to eurostat.eu, indicate that the share of 16-74 year olds who ordered or purchased products or services via the Internet for private purposes, and has increased in the EU28 and reached 57% in 2017, representing an increase of 13 percentage points compared to 2012 (see Figure 9). In 2017, approximately three quarters or more individuals in Germany and the Netherlands ordered or purchased products or services via the Internet, and this share increased to almost four-fifths in Luxembourg, Denmark (80% in both countries), Sweden (81%) and United Kingdom (82%). On the other hand, this ratio was less than 30% in Croatia and 20% in Bulgaria and Romania. In addition to the four EU Member States reporting a break in the timeframe - Estonia, Latvia, Romania and Sweden - they recorded the largest increase in the proportion of people who ordered or purchased products or services via the Internet in 2012-2017, then the Czech Republic (24 percentage points), followed by Spain (20 percentage points). Not surprisingly, the smallest increase (6 or 7 percentage points) was recorded in Denmark and Finland, where the percentage of individuals

who ordered or purchased online products or services was already relatively high compared to other Member States; similarly in Norway. The share of individuals who ordered products or services via the Internet grew at a relatively modest pace in Ireland and Croatia.

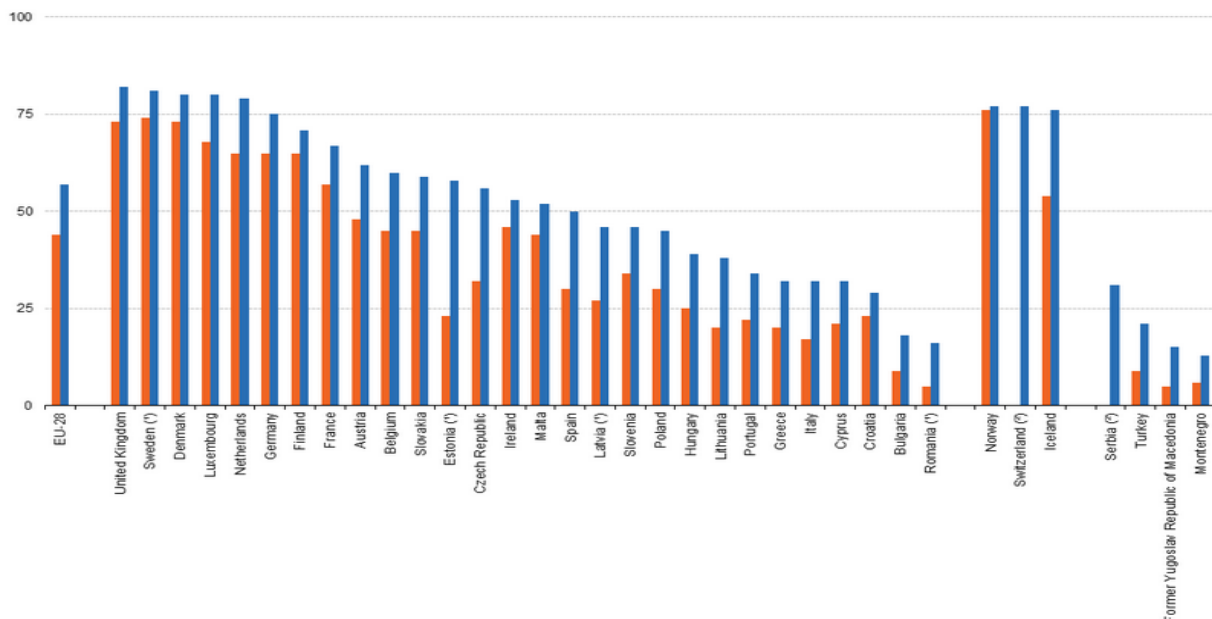

Figure 1: Purchasing and ordering products and services via the Internet (ec.europa.eu)

In the information world, it is sometimes very difficult to get the information we need. One of the biggest problems of the current business is the fact that most managers have too much information. They make them blind so they do not know how to deal with them. This is a very alarming signal of chaos in the information society. In excess of irrelevant information, it is easy to lose orientation, and this blurring then brings a very significant loss of time that can be used to perform effective activities (Dorčák, Pollák, 2010).

### 3. METHODS AND METHODOLOGY

The objective of the research was to analyse the impact of Internet purchases on the surveyed consumers and to find out differences in internet buying from the point of view of the Slovak consumer. The subject of research was consumers living in the region of Eastern Slovakia. Primary information was obtained by own collection. We used the questionnaire method to collect the views and attitudes of the respondents. The primary data obtained was then processed in the Statistica statistical program. To confirm or deny the established hypothesis, the t-test method was used for two independent selections.

H<sub>1</sub>: We assume that there are statistically significant differences in internet buying between consumers depending on their current economic activity.

### 4. SURVEY RESULTS

The sample consisted of 155 respondents who were inhabitants of the Prešov region. Out of the 155 surveyed respondents, 98 were women and 57 were men. Another important socio-demographic criterion for the research sample is education. Of the total, respondents with the highest level of university education, represented by 62 people (40%), were the largest. The following important group was respondents who completed secondary education with a school leaving examination. This group consisted of 45 individuals (29%). 41 people (26.5%) completed second degree university education.

The smallest representation was made up of three individuals (1.9%) who completed only elementary education and respondents with secondary education without a school leaving examination (2.6%). The largest representation in the economic activity was the employed respondents, making up half of the surveyed people, representing 50.3%. Then the students who represented 60 respondents (38.7%). Research was attended by a lower representation of unemployed respondents 5.2% and individuals who are on maternity leave 4.5%. Two respondents were retired and thus represented a group of 1.3%. In questionnaire research, we also focused on finding out which of our products consumers are ordering via the Internet most often. Respondents had a choice of the options outlined in Table 1.

*Table 1: Most frequently ordered products via the Internet (output of the STATISTICA 10 statistical program)*

		N	%	Useful %	Cumulat. %
Useful	electronics	40	25.8	25.8	25.8
	clothing and footwear	55	35.5	35.5	61.3
	cosmetics	15	9.7	9.7	71
	perfume	10	6.5	6.5	77.5
	groceries	2	1.3	1.3	78.8
	Trips and holidays	13	8.4	8.4	87.2
	books, CDs, DVDs	20	12.8	12.8	100
	Total	155	100	100	

The results outlined in table 1 show that the surveyed consumers most often order online clothing and footwear by 55 respondents (35.5%). Electronics are most often purchased via the Internet by 40 respondents. Other popular products include books, CDs, DVDs, which is purchased by 20 respondents (12.8%). Respondents also focus on cosmetics (9.7%) and on trips and holidays (8.4%). Only two respondents said that they buy food via the internet. To the question 'Which factors influence you when buying via the Internet?', respondents said the following: the majority of respondents, 92 (59.4%), agreed that the factor that most influences them when shopping online is the price of the product. The following factor according to the research sample is a saving by 32 respondents (20.6%). 17 respondents believe home delivery is an influencing factor and 13 respondents (8.4%) point to unlimited opening hours. Only one individual thinks that loyalty is the factor that affects us when buying via the Internet. To express satisfaction with the Internet purchase, the overwhelming majority of respondents think they are quite satisfied (85 respondents) and other 67 individuals are also satisfied, representing 43.2%. Only three respondents are less satisfied with internet shopping, and there is no one in our research sample who would be dissatisfied with internet shopping. In the following part of the paper, the data that we used to test our hypothesis are statistically processed. When testing the statistical hypothesis, we are still testing the so-called zero hypothesis. It says that there is no difference between the groups compared, nor between their characteristics (averages, orders). The difference found can be attributed by chance and does not actually exist. The opposite of the zero hypothesis is an alternative hypothesis, which says that differences exist and are due to group differences.

The basic indicator that tells us to reject the zero hypothesis or not is the p (value of statistical significance, first order error, alpha error). This value tells about the likelihood of rejecting the zero hypothesis, because we want to minimize the probability of error, 5% ( $p = 0.05$ ) is used as the base boundary. If  $p < 0.05$ , we reject the zero hypothesis, i.e. that we accept an alternative hypothesis and the conclusion is that there is a difference between the compared groups. If  $p > 0.05$  we do not reject the zero hypothesis and we assume that there is no difference between the groups. The objective of the solution to this research problem is to find out if there are statistically significant differences in Internet buying among consumers depending on their current economic activity. In connection with the above-mentioned research problem, we tested the following research hypothesis:

H<sub>1</sub>: We assume that there are statistically significant differences in internet purchasing between consumers depending on their current economic activity.

In the framework of the following comparison, we observed the differences between consumers depending on their economic activity in the surveyed items. In terms of economic activity, we compared only students and employees because there were not enough respondents within the other categories of economic activity. We used a t-test for two independent selections, the results of which are presented in the table below.

*Table 2: Comparison of the average response score of respondents based on economic activity (output of the STATISTICA 10 statistical program)*

Question	Econ. activity	N	Average	Standard variation	t	Degree of freedom	p
8. When buying via the internet do you prefer Slovak products rather than foreign ones?	student	57	3.087	0.830	0.612	136	0.879
	employed	81	3.111	0.922			
10. Does an Internet advertising affect you?	student	57	3.105	1.030	- 0.424	136	0.769
	employed	81	3.160	1.123			
<b>13. Have you purchased a product based on an advertising for the last period (1 month) via the Internet?</b>	<b>student</b>	<b>57</b>	<b>3.824</b>	<b>1.135</b>	<b>- 0.803</b>	<b>136</b>	<b>0.038</b>
	<b>employed</b>	81	3.382	1.270			
17. What is your overall satisfaction with internet shopping?	student	57	1.684	0.505	0.533	136	0.163
	employed	81	1.555	0.547			

As can be seen in table 2, the predicted differences between respondents based on their economic activity were statistically significant only in the answers to one question: 'Have you purchased a product based on an advertising for the last period (1 month) via the Internet?', where the employed respondents expressed a greater degree of agreement. Since the  $P < 0.05$  was recorded for only one question and the other comparisons were not large enough to be evaluated as statistically significant, then in this case we can reject the alternative H<sub>1</sub> hypothesis.

## 5. CONSLUSION

New ways of communicating with the customer bring the web primarily as a new multimedia. For this reason, the Internet should work on a new one, use new practices and not just traditional ones, but also customs and materials from traditional advertising. Significantly, in this case, communication is accelerating.

The website should be well-organised, multimedia-friendly and instantly shared with customers, what they can learn or buy, how they can react to a normal ad (Hanuláková et al., 2004). With internet marketing communication, Internet advertising is also an inherent part of the marketing mix. The Internet and its capabilities bring a very significant advertising space, which other media will predominate in the number of potentially affected customers. The synonym for an internet ad is usually a banner, although this is not correct because there are other forms, such as e-mail, catalogues of websites or search engines (Bernátová et al., 2003). Shiffman and Kanuk (2004) say that each and every one defends the role of the consumer who, by its decision-making, influences the demand for products, employment, resource development, but also the success or failure of some industries. It is important for a company to succeed in today's fast-growing market, so they have to know everything about consumers and understand the factors influencing their decision-making process. When buying online, Slovaks do not prefer Slovak products, but rather foreign ones. An important role is played by the cost of the product and by the postage. Internet businesses such as eBay or Aliexpress also offer the option of 'free shipping', which attracts today's young generation so much, that they are willing to wait a month for the ordered products. In this case, they do not care about the quality, only the price can reach so many customers that there is a predominance of buying on these foreign websites. This is a problem for Slovak retailers and this needs to be supported by the domestic market and by the purchase of quality home products. The decisive aspects of addressing the customer are empathy, where one needs to know how to live in a customer role as well as localization. It is good to indicate that the products are always in a warehouse and free of charge. For successful businesses, it is most important to understand the relationship between buying behaviour and marketing tools and know how to use them efficiently. An important starting point for understanding purchasing behaviour is the psychological level of consumer behaviour and learning their way of thinking their feelings, suggestions that attracts their interests.

**ACKNOWLEDGEMENT:** *This article is one of the partial outputs under the scientific research grant VEGA 1/0789/17 "Research of e-commerce with relation to dominant marketing practices and important characteristics of consumer behaviour while using mobile device platforms." VEGA 1/0806/16 "Research on issues of consumer behaviour of a new generation of customers with emphasis on identifying preferences and usability of mobile platforms in the process of e-commerce of the subjects localized predominantly on the Central European Market." KEGA 0033PU-4/2017 "Implementation of interpersonal skills in the context of the Psychology of business - inovatoin of contents and teaching."*

#### **LITERATURE:**

1. Bačík, R., Gavurová, B., Fedorko, I. (2015). The analysis of the impact of selected marketing communication factors on the online consumer behavior. *Journal of applied economic sciences*. No.7.
2. Bernátová, M. et al. (2003). *Public relations v miestnej samospráve*. Banská Bystrica: Univerzita Mateja Bela, Ekonomická fakulta.
3. Blažková, M. (2005). *Jak využiť internet v marketingu*. (1<sup>st</sup> edition). Praha: Grada Publishing.
4. Chatfield, T. (2013). *Digitálny vek: 50 myšlienok, ktoré by ste mali poznať*. (1<sup>st</sup> edition). Bratislava: Slovart.
5. Dorčák, P., Pollák F. (2010). *Marketing a e-Business*. Prešov: Prešovská univerzita v Prešove, Fakulta manažmentu.
6. Hanuláková, E. et al. (2004). *Marketing územia*. (1<sup>st</sup> edition). Bratislava: Ekonóm.

7. Hesková, M., Štarchoň, P. (2009). *Marketingová komunikace a moderní trendy v marketingu*. (1<sup>st</sup> edition). Praha: Oeconomica.
8. Jakubíková, D. (2008). *Strategický marketing – strategie a trendy*. (1<sup>st</sup> edition). Praha: Grada Publishing.
9. Jandoš, J. (2001). Ke kořenům e-podnikání a e-obchodování. (2<sup>nd</sup> edition). Business world.
10. Lelkova, A., Lorincova, T. (2017). Prediction of manipulation as a core part of social intelligence through selected personality traits in the context of business area. *International Journal of Organizational Leadership*, 2017. 6(1), p.102-108.
11. Manzoor, A. (2010). *E-commerce: An introduction*. (1<sup>st</sup> edition). Lap Lambert Academic Publishing.
12. Pollák, F., Nastišin, Ľ., Kakalejčík, L. (2015). Analytical view on the use of mobile platforms in purchasing process. *European Journal of Science and Theology*. 2015. (Vol. 11. No. 6), p.137-146.
13. Přikrylová, J., Jahodová, H. (2010). *Moderní marketingová komunikace*. (1<sup>st</sup> edition). Praha: Grada Publishing.
14. Rajčáková, E. (2009). *Podstata a význam social networkingu pre marketing*. In *Nové trendy v marketingovej komunikácii. Zborník z medzinárodnej vedeckej konferencie*, Trnava: FMK UCM v Trnave. ISBN: 978-80-8105-090-9.
15. Schiffman, L., Kanuk, L. (2004). *Nákupní chování*. (1<sup>st</sup> edition). Brno: Computer Press.
16. Suchánek, P. (2012). *E-commerce: elektronické podnikání a koncepce elektronického obchodování*. (1<sup>st</sup> edition). Praha: Ekopress. ISBN 978-80-86929-84-2
17. Štefko, R., Kirařová, A., Mudřík, M. (2015). Strategick Marketing Communication in Pilgrimage Tourism. *Conference: Proceedings of the 3rd International Conference on Strategic Innovative Marketing (IC-SIM)*, ISSN 1877-0428, 01-04 September, Madrid, Spain, p.423-430.



## GAME MECHANICS DIFFERENCES FOR KOSOVANS SOCIAL MEDIA PURCHASERS

**Fortesa Haziri**

*Faculty of Management and Economics, Tomas Bata University, Czech Republic  
haziri@utb.cz*

**Miloslava Chovancova**

*Faculty of Management and Economics, Tomas Bata University, Czech Republic  
chovancova@utb.cz*

### **ABSTRACT**

*Consumer behaviour in theoretical aspect has evolved through the years. Moreover, numerous seller have moved from physical retailer to online e-commerce websites or pages on social media. Social media within years have expanded the usage in the commercial world. In the digitization era, where consumers are daily users of technology and social media, gamification has been seen as an innovative engaging and motivating technique. So far, gamification has been employed in different fields such as healthcare, sustainability, government, transportation, education, and so on. Although, gamification appliance in consumer behaviour domain is not that much explored. Furthermore, one of gamification elements is game mechanics, which has been applied for the research purpose. This paper aims to explain the differences between consumers of different age groups and cities in Republic of Kosovo regarding the game mechanics influence when purchasing via social media. A qualitative approach followed by a non-parametric test, Chi-Square test, has been employed to describe and explain the differences between the groups. This paper contributes to the existing theory of gamification, game mechanics and its impact for social media purchasers.*

**Keywords:** *game machanics, gamification, online buying behaviour, social media, user behaviour*

### **1. INTRODUCTION**

Game elements have been used in non-game settings for engaging and motivating consumers. Gamification incorporate the application of game elements to motivate, engage and increase the cooperation of consumers changing behaviour by making the experience funnier and pleasurable. Gamification has not been explored in consumer domain only, its successful appliance in education and training, marketing, social awareness, sales or human resources is significant as well (Calderón, Boubeta-Puig, & Ruiz, 2018). Presently, internet has enhance the usage of technology, also using daily apps like Facebook, Youtube, Twitter, Instagram has impact on the communication process between the end-users and technology devices (Decker & Trusov, 2010). According to World Internet Stats report (2018) in the world are more than 4 bilion Internet users recorded in June 30, 2018. Purchasing is becoming beyond the need for a product/service. Purchasing motivation is evoked by the passable play, social collaboration, and economical reasoning. The mentioned reasons are valid and impact the amount of money spent on in-game environment. Furthermore, the designers apply unreal limitations and obstacles along with the social collaboration impact the amount of money spent on in-game environment (Hamari et al., 2017). In the same line, the in-game environment enables consumer engagement potentially is linked in the psychological engagement and behavioural engagement level. The key pillars for psychological engagement are listed as game satisfaction, game customization and social collaboration (Cheung, Shen, Lee, & Chan, 2015). Gamification models and elements have been studied by scholars differ according to the field of study. For research purpose, the authors have consider as the most suitable the MDA framework.

According to MDA (game mechanics, dynamics, aesthetics) framework (Kim & Lee, 2015; Werbach & Hunter, 2012) the gamification elements are game mechanics, game dynamics and aesthetics/emotions. The mentioned components have been employed to design a questionnaire which has been distributed in the Republic of Kosovo (hereinafter: Kosovo). Game mechanics are described as the rules, rewards, instruction and the limits for players to be followed. Those rules can be applied to online purchases as well. Despite the high number of published guidelines and broad research, the gamification and game mechanics power for engaging and motivating consumers in developing countries is not explored sufficiently. Due to lack of studies regarding game mechanics appliance, the study aim to fill this gap in theoretical and practical scope. Furthermore, the research seeks to study the differences within age groups, cities of Kosovan citizens, who use social media for purchasing purposes. By the same token, the authors did not find significant evidence to indicate that a study regarding the influence of game mechanics for social media purchasers has been investigated, notable in the developing countries.

## **2. LITERATURE REVIEW**

For gamification appliance has been created numerous models from different domains. Calderón, Boubeta-Puig and Ruiz (2018) have employed the Model-Driven Engineering (MDE) and Complex Event Processing (CEP) technology or shortly MEdit4CEP-Gam model to investigate the stages of origination, application and monitor the applicable gamification strategies. Gatautis, Vitkauskaitė, Gadeikiene and Piligrimiene (2016) have compared the SOR model and Werbach and Hunter (2012) pyramid of gamification elements. The authors have found substantial uniformity between gamification elements and SOR model. Nevertheless, no empirical research have been in the light of providing evidence regarding similarities within model. Moreover, Rahman et al., (2018) have established a framework by using gamification elements dynamics, behavior, component and aesthetic. The model canvas method, designed for cloud computing environment to persuade teachers on sharing the lessons. Kim and Lee (2015) have used the attributed of game design, the features of learning games, the ARCS (attention, relevance, confidence, and satisfaction) and MDA framework to constitute the dynamical model for gamification of learning. The MDA framework consist on the group of three elements game mechanics, game dynamics and aesthetics. Game mechanics have been employed in business education for generation Y. The results of the study highlight the differences between the classes where game mechanics were used and the not used. Moreover, in the class where game mechancis were employed, students performed better, the level of collaboration and participation was higher, expressing positive emotional reactions, and willingness to share further opinions and comments concerning the class experience (Martin Poole, Kemp, Patterson, & Williams, 2014). The class that did not used game mechancis had lower feature compared to the other class. In the healthcare domain, game mechanics have resulted in patients engagement by creating challenging, entertaining, socializing and withfuling setting (Hammedi, Leclerq, & Van Riel, 2017). Nour, Rouf and Allman-Farinelli (2018) have study the game mechanics impact on engaging young adults (18-34 years old) for improving vegetable intake. Overall, the study findings confirm the appliance of mobile-gamified elements usage of social media improved the vegetable intake. Regarding the specific elements which was found to be the most effective is earning badges. The study continues on highlighting the importance of designed by mentioning the main features such as visibility of appealing, simplified design, credibility and relevance. Comparing two groups, one of the group disuccesed the study environment and game mechanics were employed and the other group used a competitive discussion board game without game mechanics, whether the effect of presenting an activity as a game is relevant or not (Lieberoth, 2015). The sample study included students of age 20 to 43 years, and results indicate that vernacular and artifacts are powerful

psychologically as game mechanics. The both groups, fun and enjoyment were significantly important, but motivation as variable remained the same. Regarding the age, a slightly negative correlation with relatedness was presented. The most important game mechanics to engage and motivate Taiwanese students of massive open online courses have been listed as it follow based on their level of importance: virtual goods as gifts, redeemable points, team leaderboards, the Where's Wally game, trophies and badges (Chang & Wei, 2016). The study conclude that the Where's Wally game has ocured to be significantly important for engaging students of the massive open online courses. Siginificantly important according to results have been identified game points, levels, avatars or virtual identity and badges (Scheiner, 2015). However, generally speaking the participants of the study conducted by Scheiner (2015) ranked game mechanics as motivational factors for engaging consumers into idea competing provided by organizations. Another study that confirms the engagement for the participants when game mechanics are applied is Hamari (2017). The author conducted a two year experiment regarding badges usage in gamified utilitarian trading service. The results presented by the author specify the higher significance of the end-users group after introduced to gamification. Moreover, the study was in the same line with the previous research (Hamari & Koivisto, 2014; Hamari & Tuunanen, 2014), where the positive relationship between the features of the system and the behavioural changing. The psychological effect for purchasing items for game avatars has been studied by Cleghorn and Griffiths (2015). The study results emphasize that the exclusivity, function, social appeal, and payable are ranked as motivational items. Furthermore, the items allow the player to express themselves, sense pleasure, and establish long-lasting friendships. The positive influence of the purchased items, impacted also on player wellbeing. The impact of points, levels and leaderboards for an image annotation task, serve as external stimul and it results for promoting performance quantity only (Mekler, Brühlmann, Tuch, & Opwis, 2017). A depper study regarding leaderboards has been done in the terms of employee motivation and engagement. Leaderboards has been proven to be important for simple tasks and extraordinary efficient for hardly-achievable goals and tasks (Landers, Bauer, & Callan, 2017). For respondent of age 18 to 74 years, points had significant differences on speed respond for mathematics assessments (Attali & Arieli-Attali, 2015). Furthermore, the study findings notes that points did not have an impact and no impact on response accuracy. The successful appliance of game mechanics has been proven by numerous researchers as presented above. However, no research was found in the terms of comparison between cities nor age. Consequently, to explore and illuminate the differences the following hypothesis have been designed:

- H1: No differences regarding regions when game mechanics are employed.
- H2: Obtaining points, badges and leaderboards by purchasing via social media consumers differs regarding age.
- H3: The utility consumers received by purchasing via social media differ regarding age.
- H4: Forgetting the unpleasant event by purchasing via social media differs regarding age.
- H5: Motivation from rewards, points and badges by purchasing via social media for consumers differs regarding age.
- H6: Shopping via social media is a fun and enjoyable process differs based on consumers age.

### **3. METHODOLOGY**

The five questions regarding game mechanics have been designed and adjusted for Kosovan citizens where the study has been conducted. The research intends to detect the game mechanics differences for social media consumers of different age groups and cities of Kosovo. The five questions of game mechanics have been designed inspired by numerous articles (Kim & Lee, 2015; Sigala, 2015; Werbach & Hunter, 2012).

The questions employed five-point Likert scale (1 - Strongly disagree, 2 - Disagree, 3 - Neutral, 4 - Agree, 5 - Strongly agree) as a measure tool of level of agreement with the five statements. In order to explore the relationship between variables, chi-square has been employed. The chi-square test is used for analysing categorical variables which are correlated in some population. Chi-Square is a non-parametric test which investigates whether the association is significant between variables but does not specify if the association is strong or weak (Tabachnick & Fidell, 2014). To fulfil the aim of the research, chi-square test for independence has been employed. The test is beneficial to explain and explore the relationship between categorical variables. The conditions, for instance, two categorical variables, the sample size, two or more categorical or groups for each variable and the independence of observations to apply chi-square have been completely fulfilled. However, to inspect the effect size chi-square independence test, Cramer's V has been observed. Following the SPSS tutorial (2018) explanation Cramer's V contains numbers between 0 and 1 to explain the strength of the relationship between variables. After filtering only 151 valid respondents were selected for further analyses. The data have been analysed using SPSS 23.

*Table 1: The game mechanics statements (Developed by authors)*

<b>Dimension</b>	<b>Item</b>	<b>Survey statement</b>
<b>Game mechanics</b>	GM01	By buying via social media, I am able to obtain points, badges, and leader-boards
	GM02	The benefits received for buying via social media are thrilling
	GM03	Purchasing via social media helps me forget unpleasant events and makes me feel better than others
	GM04	I felt motivated by the rewards, points and badges offered by sellers
	GM05	Social media make shopping a fun and enjoyable process

To perform the chi-square has been used game mechanics, cities and age of respondents. After fulfilling the first criteria, which was to identify consumers who purchase via social media, the comparisons of age groups and cities became the purpose for conducting this research. The authors aim to identify the differences between Kosovan consumers who live in different cities. And, to compare the differences between the age of 18 and 65. The analysis started with dividing cities and age into groups. The age groups have been divided into four categories 18-24, 25-35, 36-50 and 51-65. And the cities have been divided into two categories regional cities and sub-regional cities.

#### **4. RESULTS AND DISCUSSION**

Due to facilitating management and decentralization process, Kosovo cities have been divided into regional and sub-regional cities. Kosovo consists of seven regions (Prishtinë, Mitrovicë, Pejë, Prizren, Ferizaj, Gjiilan and Gjakovë). The rest of Kosovo cities are grouped into sub-regional cities. Each region has at least four cities which are classified as sub-regional cities. According to responses from 151, the majority were from cities 68.2% and 31.8% were from sub-regional cities. From all respondents 33.1% are between the age of 18-24, followed with 53% of age 25-35, 11.9% are between the age of 36-50 and the age of 51-65 are only 2% of respondents. Along with the city and age, in the questionnaire were five questions related to game mechanics. In the report of the Kosovo Agency of Statistics (2018), in Kosovo live 1.798.506 inhabitants, 850,739 or 47.3% are from regional cities and 947,767 or 52.7% are from sub-regional cities. According to the same Agency report (2017; 2013) the number of citizens between 18 and 64 is 1,192,18 and the average age in Kosovo is 30,2. Regarding the age of internet where social media are included also the age that uses the internet the most are

10-29 (Fazliu, 2013). To perform the chi-square test has been gathering data in Kosovo from 151 respondents. The chi-square results for regions are summarized and depicted in Table 2.

*Table 2: Chi-Square test results for cities (n=151, regional city=103, sub-regional city=48)*

Items-game mechanics	Level of agreement	Regional city		Sub-regional city		Chi-Square		Cramer's V
		n	%	n	%	$\chi^2(4)$	p-value	Value
<b>GM01</b>	Strongly disagree	48	46.6	25	52.1	5.235	.264	.186
	Disagree	19	18.4	9	18.8			
	Neutral	29	28.2	7	14.6			
	Agree	5	4.9	4	8.3			
	Strongly Agree	2	1.9	3	6.3			
<b>GM02</b>	Strongly disagree	26	17.2	8	5.3	8.790	.067	.241
	Disagree	22	14.6	12	7.9			
	Neutral	34	22.5	12	7.9			
	Agree	16	10.6	7	4.6			
	Strongly Agree	5	3.3	9	6			
<b>GM03</b>	Strongly disagree	41	27.2	15	9.9	3.813	.432	.159
	Disagree	19	12.6	10	6.6			
	Neutral	26	17.2	14	9.3			
	Agree	13	8.6	4	2.6			
	Strongly Agree	4	2.6	5	3.3			
<b>GM04</b>	Strongly disagree	43	28.5	20	13.2	4.342	.362	.170
	Disagree	24	15.9	12	7.9			
	Neutral	28	18.5	8	5.3			
	Agree	5	3.3	6	4			
	Strongly Agree	3	2	2	1.3			
<b>GM05</b>	Strongly disagree	12	7.9	9	6	4.512	.341	.173
	Disagree	16	10.6	10	6.6			
	Neutral	38	25.2	10	6.6			
	Agree	24	15.9	12	7.9			
	Strongly Agree	13	8.6	7	4.6			

The chi-square test for independence indicated that no significant association between cities with obtaining points, badges, and leader-boards  $\chi^2(4, n=151)$ ,  $p=.264$ . Cramer's V resulted 0.186, signifying that is a small to moderate association, namely the city has a small to moderated association on obtaining points, badges, and leader-boards. For the benefits of purchasing via social media are thrilling and cities, the chi-square test results for independence with no association  $\chi^2(4, n=151)$ ,  $p=.067$ . Cramer's V resulted with 0.241 signifying that is a small to moderate association between regions and the benefits of purchasing via social media. For purchasing via social media and forgetting unpleasant events and cities differences, no significant association was identified  $\chi^2(4, n=151)$ ,  $p=.432$ . Regarding Cramer's V, which resulted 0.159, the strength of the association is weak or low. GM04, which include the statement, whether consumers feel motivated by the rewards, points and badges offered by sellers and the cities' differences, no significant association was identified  $\chi^2(4, n=151)$ ,  $p=.362$ . As well, Cramer's V 0.170 indicates a low association. No significant association was identified between cities and consumers who consider shopping via social media as fun and enjoyable process  $\chi^2(4, n=151)$ ,  $p=.341$ . Cramer's V resulted 0.173 signifying that is a small to moderate association. After analysing the results of chi-square, lead to accept the H1 hypothesis, due to not statistically significant found. The authors aimed to identify the differences between consumers when game mechanics are applied who live in cities that are qualified as regional cities and sub-regional cities, apparently no differences were noticed. The same instructions have been applied to perform chi-square for age groups. The results of chi-square are displayed in Table 3.

Table 3: Chi-Square test results for age (n=151, 18-24=50, 25-35=80, 36-50=18, 51-65=3)

Game mechanics items	Level of agreement	Age								Chi-Square		Cramer's V
		18-24		18-24		25-35		51-65		$\chi^2(12)$	p-value	
		n	%	n	%	n	%	n	%			
GM01	Strongly disagree	31	62	35	43.8	6	33.3	1	33.3	22.217	.035	.221
	Disagree	8	16	18	22.5	1	5.6	1	33.3			
	Neutral	9	18	19	23.8	7	38.9	1	33.3			
	Agree	2	4	3	3.8	4	22.2	0	0			
	Strongly Agree	0	0	5	6.3	0	0	0	0			
GM02	Strongly disagree	16	32	15	18.8	3	16.7	0	0	16.695	.161	.192
	Disagree	7	14	24	30	3	16.7	0	0			
	Neutral	16	32	19	23.8	8	44.4	3	100			
	Agree	7	14	13	16.3	3	16.7	0	0			
	Strongly Agree	4	8	9	11.3	1	5.6	0	0			
GM03	Strongly disagree	25	50	25	31.3	6	33.3	0	0	10.616	.562	.153
	Disagree	8	16	18	22.5	2	11.1	1	33.3			
	Neutral	11	22	23	28.7	5	27.8	1	33.3			
	Agree	3	6	10	12.5	3	16.7	1	33.3			
	Strongly Agree	3	6	4	5	2	11.1	0	0			
GM04	Strongly disagree	29	58	28	35	5	27.8	1	33.3	28.076	.005	.249
	Disagree	10	20	22	27.5	4	22.2	0	0			
	Neutral	8	16	21	26.3	7	38.9	0	0			
	Agree	3	6	7	8.8	0	0	1	33.3			
	Strongly Agree	0	0	2	2.5	2	11.1	1	33.3			
GM05	Strongly disagree	12	24	7	8.8	1	5.6	1	33.3	20.154	.064	.211
	Disagree	5	10	17	21.3	4	22.2	0	0			
	Neutral	13	26	28	35	7	38.9	0	0			
	Agree	17	34	16	20	2	11.1	1	33.3			
	Strongly Agree	3	6	12	15	4	22.2	1	33.3			

The chi-square test for independence indicated that significant association are identified between age groups and obtaining points, badges, and leader-boards  $\chi^2$  (12, n=151), p=.035. Cramer's V resulted 0.221, signifying that is a small to moderate association, namely the age has a small to moderated association, whether the points, badges, and leader-boards are obtained. For the benefits of purchasing via social media are thrilling and age groups, the chi-square test results for independence indicated that no significant association  $\chi^2$  (12, n=151), p=.161. Cramer's V resulted with 0.192 signifying that is a small to moderate association between age group and the benefits of purchasing via social media. For purchasing via social media and forgetting unpleasant events and age groups differences, no significant association was identified  $\chi^2$  (12, n=151), p=.562. Regarding Cramer's V, which resulted 0.153, which estimates a weak or low strength of the association. GM04, which in the statement included, whether consumers feel motivated by the rewards, points and badges offered by sellers and the age groups differences, the association is statistically significant  $\chi^2$  (12, n=151), p=.005. Cramer's V 0.249 results indicates a low to moderated association. No significant association was identified between age groups with shopping via social media as fun and enjoyable process  $\chi^2$  (12, n=151), p=.064. Cramer's V resulted 0.211 signifying that is a low to moderate association. The results of chi-square, indicate that H2 and H5 are accepted due to significant differences identified. On the other hand, no statistically significant found to support H3, H4 and H6. The authors aimed to identify the differences between consumers when game mechanics are applied and age groups, apparently, differences are notice only for obtaining points, badges, and leader-boards and consumers feel motivated by the rewards, points and badges offered by sellers. For the rest of game mechanics statements no differences were noticed. The justification of having these results lies on the overall economical development. Kosovo is located in the centre of Western Balkan.

Is poor country, according to World Bank report (2018a), during 2017 the annual GDP growth was 3.7% but in 2018 is expected to be 4.0%. Regarding GDP per capita annual growth for 2017 was 2.9% and for 2018 is expected to be 3.3%. Additionally, the GDP per capital is above USD 4. In 2016 World Bank report (2018b) the unemployment rate was 27.47. Lastly, the economy is highly concentrated in imported products, during 2015, the exports of goods was EUR 325.3 million but imports of goods for 2015 were EUR 2 634.7 million (Krasniqi et al., 2016).

## 5. CONCLUSION

The results of the current research depict that for Kosovan consumers game mechanics appliance do not differ in cities but differs in age groups. Due to the fact that, Kosovo is a small country and the citizens are very close to each other, therefore, the differences between the cities were not identified. However, the differences in are not the same in all ages. Regarding obtaining points, badges, and leader-boards and consumers feel motivated by the rewards, points and badges offered by sellers differences in age groups and game mechanics were identified. For the rest of game mechanics statements no differences were noticed. On the other hand, regarding the benefits received for buying via social media are thrilling, forgetting unpleasant events by shopping via social media, and shopping via social social media is fun and enjoyable process no differences were identified for game mechanics appliance despite age group. Furthermore, the economy is highly depended in import goods, and it takes place in the group of low income country, namely consumers will be motivated by obtaining rewards, points and badges. The motivational items at the end are expected to be financially beneficial. The aim of the research was to explore the differences between consumers of different age groups and cities regarding the game mechanics influence when purchasing via social media. Additionally, in this study, has been made three primary contributions. Firstly, it is demonstrated game mechanics appliance for cities are not important regarding Kosovan consumer behaviour but age is an important indicator for the trade market. Numerous of research are available on which to base further exploration of game mechanics, and a wealth of additional moderators and mediators are worth exploring. The findings of this study are useful for private companies, mostly with the main purpose to attract and motivate consumers for further purchasing behaviour. The results are significantly useful to companies which are trying to sell their products/services via social media. Therefore, this research creates a value added on game mechanics, gamification and consumer behaviour literature. As any other research, this has its limitations. Further study can be done in other countries. Since the study is conducted only for consumers who purchase via social media, it would be very interesting to compare the results for consumers who purchase offline. Also further study can be done by adding other variables like education, gender and incomes.

**ACKNOWLEDGEMENT:** *The authors are thankful for the financial support provided by the Internal Grant Agency of Tomas Bata University in Zlin, no. IGA/FaME/2018/2020: Consumer behaviour changes and entrepreneurship for market development through digitization.*

## LITERATURE:

1. Attali, Y., & Arieli-Attali, M. (2015). Gamification in assessment: Do points affect test performance? *Computers & Education*, 83, 57–63.  
<https://doi.org/10.1016/j.compedu.2014.12.012>
2. Berg, R. G. van den. (2018). Chi-Square Independence Test. Retrieved November 6, 2018, from <https://www.spss-tutorials.com/chi-square-independence-test/#what-is-it>

3. Calderón, A., Boubeta-Puig, J., & Ruiz, M. (2018). MEdit4CEP-Gam: A model-driven approach for user-friendly gamification design, monitoring and code generation in CEP-based systems. *Information and Software Technology*, 95, 238–264. <https://doi.org/10.1016/J.INFSOF.2017.11.009>
4. Chang, J. W., & Wei, H.-Y. (2016). Exploring Engaging Gamification Mechanics in Massive Online Open Courses. *Educational Technology & Society*, 19(2), 177–203.
5. Cheung, C. M. K., Shen, X.-L., Lee, Z. W. Y., & Chan, T. K. H. (2015). Promoting sales of online games through customer engagement. *Electronic Commerce Research and Applications*, 14(4), 241–250. <https://doi.org/10.1016/j.elerap.2015.03.001>
6. Cleghorn, J., & Griffiths, M. D. (2015). Why Do Gamers Buy “Virtual Assets”? *Digital Education Review*, (27), 85–104.
7. Decker, R., & Trusov, M. (2010). Estimating aggregate consumer preferences from online product reviews. *International Journal of Research in Marketing*, 27(4), 293–307. <https://doi.org/10.1016/J.IJRESMAR.2010.09.001>
8. Fazliu, A. (2013). *Internet Penetration and Usage in Kosovo 2013*. Prishtine.
9. Gatautis, R., Vitkauskaitė, E., Gadeikiene, A., & Piligrimiene, Z. (2016). Gamification as a Mean of Driving Online Consumer Behaviour: SOR Model Perspective. *Engineering Economics*, 27(1), 90–97. <https://doi.org/10.5755/j01.ee.27.1.13198>
10. Hamari, J. (2017). Do badges increase user activity? A field experiment on the effects of gamification. *Computers in Human Behavior*, 71, 469–478.
11. Hamari, J., Alha, K., Järvelä, S., Kivikangas, J. M., Koivisto, J., & Paavilainen, J. (2017). Why do players buy in-game content? An empirical study on concrete purchase motivations. *Computers in Human Behavior*, 68, 538–546. <https://doi.org/10.1016/j.chb.2016.11.045>
12. Hamari, J., & Koivisto, J. (2014). Measuring flow in gamification: Dispositional Flow Scale-2. *Computers in Human Behavior*, 40, 133–143. <https://doi.org/10.1016/J.CHB.2014.07.048>
13. Hamari, J., & Tuunanen, J. (2014). Player Types: A Meta-synthesis. *Transactions of the Digital Games Research Association*, 1(2), 29–53.
14. Hammedi, W., Leclercq, T., & Van Riel, A. C. R. (2017). The use of gamification mechanics to increase employee and user engagement in participative healthcare services. *Journal of Service Management*, 28(4), 640–661. <https://doi.org/10.1108/JOSM-04-2016-0116>
15. Kastrati, A., Uka, S., Sojeva, A., Tahiri, E., & Berisha, V. (2017). *Parashikimi i popullsisë së Kosovës 2017 – 2061*. Prishtinë.
16. Kim, J. T., & Lee, W.-H. (2015). Dynamical model for gamification of learning (DMGL). *Multimedia Tools and Applications*, 74(19), 8483–8493. <https://doi.org/10.1007/s11042-013-1612-8>
17. Krasniqi, I., Ulaj, R., Berisha, I. T., Qevani, B., Bellaqa, B., Rrustemi, I., ... Salihu-Morina, A. (2016). *Statistical Yearbook of the Republic of Kosovo*. Prishtinë.
18. Krasniqi, I., Ulaj, R., Berisha, I. T., Qevani, B., Kastrati, A., Rrustemi, I., ... Morina, A. S. (2018). *Vjetari Statistikor i Republikës së Kosovës 2018*. Prishtinë.
19. Landers, R. N., Bauer, K. N., & Callan, R. C. (2017). Gamification of task performance with leaderboards: A goal setting experiment. *Computers in Human Behavior*, 71, 508–515. <https://doi.org/10.1016/j.chb.2015.08.008>
20. Lieberoth, A. (2015). Shallow Gamification: Testing Psychological Effects of Framing an Activity as a Game. *Games and Culture*, 10(3), 229–248. <https://doi.org/10.1177/1555412014559978>
21. Martin Poole, S., Kemp, E., Patterson, L., & Williams, K. (2014). Get your head in the game: using gamification in business education to connect with generation Y. *Journal for Excellence in Business Education*, 3.



22. Mekler, E. D., Brühlmann, F., Tuch, A. N., & Opwis, K. (2017). Towards understanding the effects of individual gamification elements on intrinsic motivation and performance. *Computers in Human Behavior*, 71, 525–534. <https://doi.org/10.1016/j.chb.2015.08.048>
23. Nour, M. M., Rouf, A. S., & Allman-Farinelli, M. (2018). Exploring young adult perspectives on the use of gamification and social media in a smartphone platform for improving vegetable intake. *Appetite*, 120, 547–556. <https://doi.org/10.1016/j.appet.2017.10.016>
24. Rahman, M. N. A., Jaafar, J., Kadir, M. F. A., Shamsuddin, S. N., & Saany, S. I. A. (2018). Cloud Based Gamification Model Canvas for School Information Management. *International Journal of Engineering & Technology*, 7(2.14), 28–31. <https://doi.org/10.14419/ijet.v7i2.14.11148>
25. Scheiner, C. W. (2015). The Motivational Fabric of Gamified Idea Competitions: The Evaluation of Game Mechanics from a Longitudinal Perspective. *Creativity and Innovation Management*, 24(2), 341–352. <https://doi.org/10.1111/caim.12115>
26. Sigala, M. (2015). The application and impact of gamification funware on trip planning and experiences: the case of TripAdvisor's funware. *Electronic Markets*, 25(3), 189–209. <https://doi.org/10.1007/s12525-014-0179-1>
27. Stats, I. W. (2018). World Internet Users Statistics. Retrieved November 6, 2018, from <https://www.internetworldstats.com/stats.htm>
28. Tabachnick, B. G., & Fidell, L. S. (2014). *Using multivariate statistics* (6th edition). Harlow: Pearsom Education Limited.
29. Werbach, K., & Hunter, D. (2012). *For the win: how game thinking can revolutionize your business*. Wharton Digital Press .
30. World Bank. (2018a). *Kosovo - Selected Indicators*. Prishtinë.
31. World Bank. (2018b). Unemployment. Retrieved November 8, 2018, from <https://data.worldbank.org/indicator/SL.UEM.TOTL.NE.ZS?locations=XK>
32. Zabërgja, S., Sojeva, K., Kastrati, A., Maxharri, Z., Gashi, D., Uka, S., ... Keilman, N. (2013). *Parashikimi i popullsisë së Kosovës 2011 – 2061*. Prishtinë.

## SUPPRESSION OF CORRUPTION AND SPECIAL INVESTIGATION TECHNIQUES IN CROATIA WITH REFERENCE TO STANDARDS OF EUROPEAN COURT OF HUMAN RIGHTS

**Barbara Herceg Paksic**

*Faculty of Law, Josip Juraj Strossmayer University  
Stjepana Radića 13, Osijek, Croatia  
bherceg@pravos.hr*

### **ABSTRACT**

*The paper deals with the problem repressive anticorruption reaction in Croatian legislation and jurisprudence. It includes respective changes brought by the Criminal Code, entered into force on January 1<sup>st</sup>, 2013. These changes were focused on harmonization of Croatian and international anticorruptive standards, in order to set a better basis for prosecution of perpetrators of these offences. In this regard, it focuses on the specific problem: difficulties in collecting evidence when it comes to corruption. To overcome this problem, special investigation techniques are used. Two of them are of a significant value: the use of undercover investigators and the simulations of giving and receiving a bribe. However, there is a potential risk of entering in punishable stage – incitement to commission of an offence. In order to avoid this risk as well as to enable the conviction of perpetrators, it is necessary to analyse the separation line between incitement and legitimate actions under investigator`s authority. This is done by taking in consideration the relevant provisions of Croatian legislation, judicial practice as well as legal standards deriving from case law of European Court of Human Rights.*  
**Keywords:** *corruption, criminal offence, incitement, undercover investigator, simulation*

### **1. INTRODUCTORY NOTES**

“Society had to find techniques for containing that type of criminal activity which destroyed the foundations of democratic societies” Case of Teixeira de Castro v. Portugal, § 32. While many studies have confirmed the high level of social awareness when it comes to corruption, the unwillingness of citizens to report it remains emphasized. Two problems prevent better prosecution of corruption offences. The first is citizen’s report reluctance, with significant influence of the lack of trust in judicial institutions. The second one is collecting evidence difficulties, once the report has been made. In process of collecting information, evidence and subsequent criminal procedure, the “classical” investigation methods are of little help. European Court of Human Rights (hereinafter ECtHR) emphasized that corruption has become a major problem in many countries so that the use of special investigative techniques, such as undercover agents may be necessary, provided that the rights and undertakings deriving from international multilateral conventions concerning special matter, for example human rights, are not affected. This use cannot in itself infringe the right to fair trial, but on account of the risk of police incitement entailed by such techniques, their use must be kept within clear limits.<sup>1</sup> Taking this into account, the basic features of anti-corruption protection in Croatian criminal substantive and procedural law are presented. The fundamental anti-corruption offences in the special part of the Criminal Code (hereinafter CC) are described as well as special investigation techniques from the Criminal Procedure Code (hereinafter CPC). The latter are activities of police undercover agents and simulation of giving or receiving a bribe. Although these techniques imply a certain level of confidentiality, due to the great potential of human rights violations (especially the right to a fair trial) is needed to examine available judicial practice in order to give insight to achieved standards in this area.

---

<sup>1</sup> Ramanuskas v Lithuania, App no 74420/01, 5 February 2008, §§ 50-51.

## 2. A SHORT OVERVIEW ON CROATIAN STATE OF PLAY AND BASIC REPRESSIVE FRAMEWORK

None of many attempts of corruption definition is regarded as comprehensive and widely accepted. It is current and "flexible" social phenomenon. Legal authors have reached a consensus on its key determinants- any abuse of public authority for private gain of the person performing public service. In the narrow sense, it is a relation where at least two persons are damaging the public interest with inadmissible exchange in order to achieve personal interests. They violate the moral and legal norm and the rule of law as the foundations of democratic development.<sup>2</sup> Secret «operations», without witnesses, in which both sides benefit from inadmissible exchange derived from corrupt agreement, are difficult to prove. There is no interest in reporting since all participants benefit from it. Prosecution statistics regarding these criminal offences do not indicate a social problem: only a small part of the corruptive practice is ultimately prosecuted. Further, discrepancy between the corruptive behaviour in reality and ultimately convicted perpetrators is showing an extremely large «dark number».<sup>3</sup> The actual situation could hardly be reached.<sup>4</sup> If the government announces zero tolerance to corruption, it can easily suffer a rapid and irreversible loss of legitimacy.<sup>5</sup> The first National Programme for the fight against corruption was adopted in 2002. To meet more serious standards, measures for suppression of corruptive practice were intensified in 2005, with the beginning of negotiations for the EU accession.<sup>6</sup> In this context the UN Convention against Corruption (UNCAC)<sup>7</sup> is an important instrument promoting threefold approach on a global scale (education, prevention and repression). A comparative analysis of Croatian "critical areas" is not likely to differ from other countries that "struggle" with the problem of corruption.<sup>8</sup> Criminal law traditionally comes as a "last resort action" or ultima ratio mean. In the new Croatian CC,<sup>9</sup> offences have been modified to comply with accepted international obligations.<sup>10</sup>

<sup>2</sup> Horvatić, Ž. et al. (2002) *Rječnik kaznenog prava*, Masmmedia, Zagreb, p. 199. Derenčinović, D. (2002) in *Mit(o) korupciji*, Nocci, Zagreb, 2001, p. 42, indicates different types of corruption such as: individual, systemic, indirect, competitive, active and passive, street, bargaining, political, transactional, nepotistic, investment...etc. Additionally, we refer to some other papers, for example, Derenčinović D. (1999), *Kaznenopravni aspekti korupcije s elementom inozemnosti*, Hrvatski ljetopis za kazneno pravo i praksu Vol. 6, No. 1, pp. 155-190. Derenčinović D. (2003), *O usklađivanju hrvatskog kaznenog zakonodavstva s pravnom stečevinom Europske unije na području pravosuđa i unutarnjih poslova-korupcija i terorizam*, Hrvatska pravna revija, Vol. 3, No. 6, pp. 99-115.

<sup>3</sup> Solution can be in improving the system of detection of these offences and system of seizure of financial gain, together with the withdrawal of criminal prosecution for the bribe-giver who would cooperate in the prosecution. Derenčinović, D. (2008), *Prilog raspravi o rasvjetljavanju velike „tamne brojke“ kod korupcijskih kaznenih djela* in Mlinarević, M. (ed), *Korupcija-pojavni oblici i mjere za suzbijanje*, Inženjerski biro, Zagreb, pp. 172-185.

<sup>4</sup> According to the latest data from the Croatian Bureau of Statistics (for 2017), in the total number of convicted persons (12 091), only 0.8% were convicted for Offences against official duties (97). Out of this number 58 persons were convicted for the offence of Abuse of office and office authority, 14 for Accepting a bribe, 18 for Offering a bribe, 3 for Trading in influence, and 1 persons for Bribe offering for trading in influence. Adult Perpetrators of Criminal Offences, Reports, Accusations and Convictions (2018), Statistical Reports, Croatian Bureau of Statistics, Zagreb, p. 136.

<sup>5</sup> A successful fight against corruption requires a simple legal system in which outdated laws must be revised and ineffective ones repealed. Provisions should be simple and without *lex imperfect* characteristics that help the participants of economic life and citizen. Köhalmi L. (2010), *Büntetőjogi eszközök a politikai korrupció elleni küzdelemben* in Ferenc, C.; Horváth, C.; *Politika és korrupció – A törvényesség és a törvénytelenység határai. Konferenciakötet*, Conference Volume. Pécsi Tudományegyetem Állam-és Jogtudományi Kar, PTE ÁJK Politikatudományi és Társadalomelméleti Tanszék, Pécs-Baranyai Értelmiségi Egyesület, pp. 285-309, p. 302.

<sup>6</sup> Herceg, B.; Köhalmi, L., *Fight against Corruption in Hungary and Croatia*, in: Drinocsi, T.; Župan, M.; Ercsay, Z.; Vinković, M. (eds): *Contemporary Legal Challenges: EU- Hungary-Croatia*, Osijek- Pecs, 2012, pp. 293-315, p. 309.

<sup>7</sup> [https://www.unodc.org/documents/brussels/UN\\_Convention\\_Against\\_Corruption.pdf](https://www.unodc.org/documents/brussels/UN_Convention_Against_Corruption.pdf) (14 September 2018). The Croatian Parliament passed the Act on Ratification of the UN Convention against Corruption on 04 February 2005, see Official Gazette-International Agreements 2/2005.

<sup>8</sup> These areas are: conflict of interest in public office, financing of political parties, the right of access to information, public administration and public procurement. Herceg, Köhalmi, *op. cit.* in n 6, p. 312.

<sup>9</sup> Official Gazette 125/2011; 144/2012, 56/2015, 61/2015, 101/2017, entered into force on 1 January 2013.

<sup>10</sup> It was necessary to harmonize anti-corruption legislation with international regulations, especially with The Criminal Law Convention on Corruption and the Additional Protocol- ETS 173 and 191. Available at <https://www.coe.int/en/web/conventions/full-list/-/conventions/treaty/173> (01 September 2018)

The Chapter XXVIII (Criminal Acts against Official Duty) includes a list of ten criminal offences.<sup>11</sup> The protective object is public authority regarded as legal and effective execution guarantees, which together with respect of the rule of law strengthen public confidence in the institutional system. The basic characteristic is not the fact that the perpetrator is an official person, but the endangerment of regular functioning of services of public interest.<sup>12</sup> During the reform, key criminal offences were altered according to the at-the-time suggestions made by GRECO.<sup>13</sup> The word bribe was introduced in the offences descriptions (previously only in titles), using the expressions “gift” or “favour” in descriptions. Important suggestions in the regulation of “active bribery” (Bribe Giving, Art. 294 of CC) were related to the exemption of punishment (for a perpetrator who reported the offence before it was discovered) as well as the possibility of returning the given bribe to his provider.<sup>14</sup> “Passive bribery” or Bribe Acceptance is regulated in Art. 293 of CC. It is important to emphasize that a subsequent request of the official or responsible person to receive a bribe is also subjected to penalty- up to one year imprisonment. The gain from criminal offence is to be subtracted under the general provisions of the Art. 77 of CC (Conditions and manner of material gain subtracting).<sup>15</sup> Because of complex composition of the former Unlawful intercession, two new incriminations were made: Influence Trading (Art. 295 CC) and Giving bribe for trading in influence (Art. 296 CC). Slovenian criminal law also practices this approach. Position and Authority Abuse (Art. 291 CC) is the first criminal offence in mentioned chapter and is committed by an official or responsible person, who uses his/her position or authority and exceeds the limits of powers or does not perform his/her duty and thus to himself or another person obtains benefits or causes damage to another person. If a substantial financial gain or considerable damage<sup>16</sup> is caused, it becomes severe offence form. Like many other countries, Croatia has not yet reached the satisfactory level of reporting corruptive practice. Social developments towards the so-called “whistle-blowers”<sup>17</sup> are sufficient indicators. Leaving the mere proclamation of their protection and providing it in reality is the necessary first step since problem is not the legislation but its implementation.

---

<sup>11</sup> Position and Authority Abuse, Unlawful Intercession, Bribe Acceptance, Bribe Giving, Influence Trading, Bribery for trading in influence, Confession Extortion, Unlawful Search, Unlawful release of a person deprived of liberty and Official Secret Disclosure.

<sup>12</sup> Derenčinović, D., in Derenčinović, D. (ed.): *Posebni dio kaznenog prava [The Special Part of Criminal Law]* Faculty of Law, University in Zagreb, 2013, p. 227.

<sup>13</sup> «Group of States against Corruption» was founded in 1999, within the Council of Europe. It evaluates each country and issues a report whether an individual country meets its international obligations in the field of corruption. Suggestions were made to the Croatian regulations of passive and active bribery in the public sector and ambiguities in their legal descriptions when the bribe is intended for a third party. See Kralj, T.; Dragičević Prtenjača, M. (2010), *Korupcijska kaznena djela protiv službene dužnosti-s analizom prijedloga njihovih izmjena*, Hrvatski ljetopis za kazneno pravo i praksu, Vol. 17, No. 2, p. 734.

<sup>14</sup> See Greco, Third Evaluation Round, Compliance Report on Croatia, Incriminations (ETS 173 and 191, GPC 2), recommendations iv. and v. (§22-§29), available <https://www.coe.int/en/web/greco/evaluations/croatia> (07 October 2018) Taking into account that the bribe giver will usually report the offence if he had remained deprived of the fulfilment of his interests as part of corrupt agreement, it is not justified to favour him in this way (i.e. mandatory exemption from punishment). So currently, Croatian provision contains only the *possibility* of exemption of punishment with *ratio legis*- stimulation of reporting corruptive practice. Restoring the bribe amount to the giver is no longer possible. See, Turković, K., et. al. (2013). *Komentar Kaznenog zakona*, Official Gazette, p. 370.

<sup>15</sup> The principle of material gain subtraction is one of the basic principles in Croatian criminal law, stipulated in Art. 5 CC: “No one can retain the material gain obtained from wrongful act”. It expresses the message that the crime is not worth committing or that it doesn't pay.

<sup>16</sup> According to the decision Su-IVk-4 / 2012-57 of the Criminal Department of the Croatian Supreme Court of 27 December 2012, substantial damage is considered the value of the damage exceeding 60 000 HRK (approximately 8 000 Euros).

<sup>17</sup> “Whistle-blower” is an employee, a former employee or organisation member who reports an illegal action to the competent authorities. Their protection is obligation undertaken from the Criminal Law Convention on Corruption of the Council of Europe but is at unsatisfactory level without real enforcement mechanisms. If they do not lose their jobs after they appear in public, whistle-blowers leave themselves because of their compromised health, reduced wages and impossibility of advancement.

### 3. CRIMINAL CONDUCT SIMULATION WITH REFERENCE TO JUDICIAL PRACTICE OF NATIONAL COURTS AND EUROPEAN COURT OF HUMAN RIGHTS

Having in mind mentioned difficult evidence revelation, Croatian Criminal Procedure Code (hereinafter: CPC)<sup>18</sup> provides special investigation techniques (hereinafter SIT), standardized in Art. 332-340. These techniques are also mentioned in Recommendation (2005)<sup>10</sup> of the Committee of Ministers to member states on "special investigation techniques" in relation to serious crimes including acts of terrorism.<sup>19</sup> This is a specific operating mode on behalf of competent authorities to detect, investigate, gather information on certain offences, in order to ultimately enable the prosecution. Given that this encompasses a specific intervention in human rights and freedoms, it requires the judicial supervision of the implementation and of the results obtained. There are certain limits of human rights and fundamental freedoms. It is the limit that comes from violating the provisions of the legal order. The Croatian Constitution stipulates that human rights and fundamental freedoms may be restricted only with the law, proportionate to the need, in order to protect the rights and freedoms of others, public order, morality and health.<sup>20</sup> Previous to deciding on the culpability of a perpetrator in criminal proceedings, his rights and freedoms are limited but this is a temporary restriction (with the purpose of enabling punishment of the offender), and it shall apply when there is a high probability that he is guilty of a crime.<sup>21</sup> Apart from interventions in human rights and freedoms, these measures affect the structure of the criminal proceedings, especially in an evidence-based phase. Therefore, the regulation of these actions is limited with special guidelines: a) subsidiarity, b) proportionality, c) specificity of actions, d) catalogue of crimes, e) judicial supervision, f) an exception: state attorney can order the actions in case of emergency but subsequent court convalescence must be provided. In addition, the specific purpose of the principle *audiatur et altera pars* in evidence based phase of criminal procedure is limited.<sup>22</sup> CPC regulates ten special investigation techniques<sup>23</sup>: 1) surveillance and technical recording of telephone conversations and other communications on distance; 2) interception, collection and recording of computer data; 3) entering the premises for the purpose of conducting surveillance and technical recording; 4) secret monitoring and technical recording of persons and objects; 5) use of undercover investigators and informants; 6) simulation of purchase of items and simulated bribe offering and acceptance; 7) simulation of business services or concluding simulated legal affairs; 8) supervised transport and delivery of items of criminal offence; 9) seizure and delivery of postal deliveries and 10) reconciliation of computer data.<sup>24</sup> Specific substantive requirements are needed for their use. If the investigation is not possible in any other way or possible only with disproportionate difficulties, the state attorney must send a written and reasoned request to the

<sup>18</sup> Official Gazette 152/2008, 76/2009, 80/2011, 91/2012, 143/2012, 56/2013, 145/2013, 152/2014, 70/2017.

<sup>19</sup> <https://wcd.coe.int/ViewDoc.jsp?id=849269&BackColorInternet=9999CC&BackColorIntranet=FFBB55&BackColorLogged=FFAC75> (01 October 2018). SIT are applied by the competent authorities in the context of criminal investigations for the purpose of detecting and investigating serious crimes and suspects, aiming at gathering information in such a way as not to alert the target persons. They are used where there is sufficient reason to believe that a serious crime has been committed or prepared, or is being prepared, by one or more particular persons or an as-yet-unidentified individual or group of individuals.

<sup>20</sup> Constitution of Republic of Croatia, Official Gazette, 56/1990, 135/1997, 113/2000, 28/2001, 76/2010, 5/2014 Art. 16.

<sup>21</sup> Krapac, D. (2014), *Kazneno procesno pravo, prva knjiga: Institucije*, Official Gazette, Zagreb, pp. 304- 305.

<sup>22</sup> Pavišić, B. (2011), *Komentar Zakona o kaznenom postupku*, Dušević and Kršovnik, Rijeka, p. 643. Also, Recommendation R (81) 12 (on economic crime) and R (01) 11 (on guidelines for the fight against organized crime). International treaties as *sedes materiae* can regulate SIT to conduct joint investigations at an international level.

<sup>23</sup> Eight of them are regulated in Art. 332, the ninth is in Art. 339, and the last in Art. 340 of the CPC.

<sup>24</sup> SIT use is not permitted in all criminal offences. As stated earlier, one of the principles of their regulation is a offence catalogue expressly providing incriminations for which implementation approval is possible. These offences are listed in Art. 334 of the CPC, i.e. war crimes, terrorism and related crimes, slavery, human trafficking, illegal deprivation of liberty, crimes against the Republic of Croatia, sexual abuse of a child under 15 years, money laundering... Regarding criminal acts against official duty, allowed only for acts in following articles: 291 (Position and Authority Abuse), 293 (Bribe Accepting), 294 (Bribe Giving), 295 (Influence Trading) and 296 (Giving a bribe for Influence Trading).

investigating judge, against a person with grounds of suspicion<sup>25</sup> that has committed one of the offences from the list. SIT enforcement is ordered by the investigating judge through written and reasoned order. Exceptionally, there is a delay risk and a reason to believe it will not be possible to get the permission on time, the State Attorney can issue a order valid for 24 hours. Later the judge decides on this, by examining its legality (may approve or disapprove the decision). The application of SIT is often subjected to Croatian Supreme Court decisions, where it is mostly disputed regarding the legality and validity of court order.<sup>26</sup>

### 3.1. Deployment of undercover agents and criminal conduct simulation

The use of the undercover investigator can be useful in investigations where traditional and conventional methods are not sufficient and productive. Corruptive practice implies the rule of mutual silence that benefits the actors; it is not realistic to expect the evidence or witnesses. The undercover investigator is a police officer, domestic or foreign, specially prepared for a certain task under secret identity that can be used in legal relations. The conventional division recognizes the ordinary (occasional) undercover agent, undertaking e.g. simulation of bribery or conclusion of business services and «real» secret agent whose task is more complex: infiltration of certain criminal groups in order to monitor their activities.<sup>27</sup> It is necessary to distinguish the undercover investigator from confidant<sup>28</sup> and from police officer. The latter uses his real identity.<sup>29</sup> When using the actions and simulations of undercover agents, the determination standard has to be stronger than in other techniques since there is a greater potential for violation of human rights and freedoms. Therefore, CPC sets one additional condition: the conduct of these actions must not represent incitement.<sup>30</sup> The examination of undercover investigator in court is subjected to other standards than those for «ordinary» witnesses. Rules established for protected witnesses apply. Otherwise, it could lead to the discovery of identity. This would not only prevent further work on the current or future cases, but also could jeopardize agent's safety. In order to prevent that while obtaining crucial information, the State Attorney and the investigating judge shall prevent unauthorized persons finding out agent's identity and shall allow for his/her examination as a protected witness.<sup>31</sup> Simulated purchase and simulated bribery are important for convergent crimes such as bribe receiving and giving. Undertaken by the police, measure is usually a single or short-term action. In relation to the undercover investigator, this action still interferes less with human rights and freedoms: the person is left the discretion to decide how he/she will ultimately behave.<sup>32</sup> Failure to comply with substantive and formal conditions for the imposition, as well as implementation mistakes will lead to the unlawfulness of the evidence, as is the case in all other SIT. This means that the evidence according to the «poisonous tree fruit» doctrine will not be eligible for criminal proceedings.

---

<sup>25</sup> Grounds of suspicion that the person committed the offence is compound and general criminal procedure term. More precisely, the degree of certainty of knowledge about the existence of the fact of committing a criminal offence. In legal terms it is a standard, which, according to the criminalistic findings fits the indications. Krapac, *op. cit.* in n 21, p. 320.

<sup>26</sup> Supreme Court of Croatia- VSRH I Kž-U 147/2017-4 from 7th December 2017, I Kž.U 102/14-4 from 3 September 2014, I Kž-U 165/15-4 from 11 January 2016.

<sup>27</sup> More, Krapac, *op. cit.* in n 21, p. 348.

<sup>28</sup> Confidant is a citizen, involved on the basis of a court decision, although operating under the same guidelines as undercover investigators with similar tasks. He can be examined on the conversation content conducted with a suspect or witness. Pavišić, *op. cit.* in n 22, p. 651. The important problem in questioning this informant is the verification of his credibility as a witness.

<sup>29</sup> *Ibid.*, p. 650.

<sup>30</sup> Art.332. sec.1. p. 5 and 6 of CPC.

<sup>31</sup> Krapac, *op. cit.* in n 21, p. 326. He can be examined about the content of the conversation which he had with persons (towards whom the special investigation technique was ordered) as well as with all participants of the crime. The testimony of the undercover investigator can be evidence in criminal procedure, but it is explicitly stipulated that the verdict as well as the decision on evaluation of the unlawfulness of the evidence, cannot be based solely on his testimony. See also Art. 333. sec. 3 CPC.

<sup>32</sup> Krapac, *loc. cit.*

### 3.2. Undercover investigator applies simulated actions- the service of revealing corruptive practice and the limits of permitted actions

Undercover agents must not engage in crime incitement, since this is punishable:<sup>33</sup> one who intentionally incites another to commit a criminal offence shall be punished as if he himself committed it.<sup>34</sup> It represents a stimulating influence on the possible perpetrator aimed at creation of crime commitment decision. The foundation of inciter's punishment lies in the fact that he is a distant initiator enabling introductory contact for criminal law provisions violation. Therefore, this action itself has inherent unworthiness. This stimulation does not have to be the only cause but it has to be crucial or determining one.<sup>35</sup> The incitement manner is not specified in CC, it appears in different forms of influencing someone's will: expressing a desire, request, command, promise of reward and persuasion.<sup>36</sup> Since the inciter is faced with mentioned punishing threat, it means that the same «penalty framework» (i.e. minimum and maximum of specific punishment) that applies to the perpetrator. This solution is justified since in Croatian literature this figure of complicity in offence is called «the spiritual father of the offence». The incitement severity as a complicity form reflects in the figure of unsuccessful incitement and the provided punishment: the situation when incitement is done but the potential perpetrator did not do anything punishable. Pursuant to Art. 37 sec. 2 PC, the inciter will be punished because of his «encouraging activities», though the perpetrator has not even tried to commit the offence.<sup>37</sup> This is actually an incitement attempt and punishable when related to a criminal offence with punishable attempt.<sup>38</sup> The incitement illegality is known in other criminal justice systems of continental European countries as well.<sup>39</sup> On the other hand, Anglo-Saxon based approaches include "police provocation" as a type of defence in criminal proceedings: a police agent provocateur provoked defendant and without such action, he would not have committed the crime. Alternatively, that the agent served strong and unacceptable methods that would lead any person to commit the criminal offence. If such a defence is successful, it leads to the exclusion of mens rea.<sup>40</sup> In reality, the level of pressure on behalf of undercover agent may be questionable which leads to the need of demarcation line from incitement, i.e. in cases of SIT of bribery simulation. There are two essential directions to this debate: first, the area of making decision to commit a crime and second, an intention based on a certain stage of a criminal offence. Making a decision is the first stage of iter criminis that should be done independently.

---

<sup>33</sup> Art. 332 sec.7 CPC.

<sup>34</sup> Art. 37 CC.

<sup>35</sup> Heine, G. (2010) in Schönke, A.; Schröder, H. (eds), *Strafgesetzbuch, 28. Auflage, Kommentar*, Verlag C. H. Beck, München, § 26 p. 522.

<sup>36</sup> Novoselec, P.; Bojanić, I. (2013), *Opći dio kaznenog prava*, University of Zagreb, Faculty of Law, p. 344. Incitement includes double intention (includes intention on two facts): the act of incitement itself and the major characteristics of incrimination.

<sup>37</sup> Different situation is when the perpetrator attempts criminal offence but, for various reasons, fails to complete it. This situation is a successful incitement, punishable under Art. 37 sec. 1 Pursuant to Art. 37 sec. 3, the figure of inappropriate incitement, also called *omnimodo facturus*: the perpetrator has already decided to commit a crime. Therefore, a «causal link» between incitement and making a decision is missing. However, in the case of a person who is just prone to commit a crime, but has not yet made a decision, incitement is possible.

<sup>38</sup> Moreover, it is an exception to the complicity accessory and an indicator of incitement as a more serious form of complicity than aiding. Unsuccessful aiding is not punishable. According to Art. 34 CC, the attempt is not punishable for all criminal offences, but only for those for which a prison sentence of five years or more can be ordered, and for other criminal offences only where the punishment for attempt is explicitly provided.

<sup>39</sup> The judge has the discretion to order a stay of a prosecution where it appears that entrapment has occurred or to exclude evidence in case of police incitement according to English Police and Criminal Evidence Act 1984. *Edward and Lewis v United Kingdom*, App No 39647/98 and 40461/98, 22 July 2003, §§31, 32. Available at <https://publications.parliament.uk/pa/ld200102/ldjudgmt/jd011025/loose-1.htm> (10 September 2018). "It is simply not acceptable that State through its agents should lure its citizens into committing acts forbidden by the law and then seek to prosecute them for doing so. That would be entrapment, a misuse of State power and abuse of the process of the courts... whose role is to stand between the State and its citizens and make sure this does not happen." House of Lords, *Regina v. Looseley* [2001] UKHL 53, 25 October 2001. The state cannot punish someone for behaviour for which the person was indicated through activities of competent authorities. It would violate contemporary standards when putting greater demands before a citizen than the state itself must adhere to. See Krapac, *op. cit.* in n 21, p. 328.

<sup>40</sup> *Ibid.*

How to determine that agent overstepped the allowed limits and influenced decision establishment is *quaestio facti*. It is not possible to establish one absolute criterion. Therefore, multiple repeated bribery simulation may and may not represent incitement. Some authors consider only low «activity» allowed (as in case when anyone else would be offering a bribe) some stipulate that even intensive offering is not the forbidden zone.<sup>41</sup> According to the widespread understanding in the German literature<sup>42</sup>, if a person wants the activities to be stopped in attempt phase so that he or someone else can prevent the completion, such behaviour would not be punishable incitement since there is no valid intention. For example, if the undercover agent practiced bribery simulation, knowing that police will act soon by stopping the further illegal actions, it would not be punishable. Under this circumstance the behaviour is useful because ultimately protects the society.<sup>43</sup> It is possible to assume that in the performing police practice, certain simulated actions can be converted from "easy" to "heavier" level, from one-time measure to the repeated one. It is possible that in practice, many incitement activities are conducted under the disguise of "testing". The question is whether and how this behaviour will later be recognized and thus sanctioned through unlawful evidence evaluation. The answer lies in a good and thorough assessment of every specific case, in the attitude of potential perpetrators, manifests of his intention towards a potential criminal offence, possible hesitation as well as other circumstances that would indicate crossing the border of permissible activities of undercover agents or informants. One more issue inherent to the Bribe Offering is worth mentioning. Pursuant CC Art. 294, sec. 1, the perpetrator is who offers, gives or promises a bribe, to official/responsible person, intended for him/her or for another person. That being said, CC finds the mere offering to be a perpetrator's role so entering the forbidden zone becomes slippery slope. Incitement contribution would be, i.e., encouragement to take (already offered by someone else) bribe, but without giving it himself. Techniques of simulated bribe offering or accepting cannot be taken into account if the contribution of police officer(s) committing the criminal offence is bigger than (criminal) contribution of the offender.<sup>44</sup>

### 3.3. National and European standards in criminal conduct simulation model

Due to greater potential of human rights violations, with emphasis to fair trial right, it is important to examine the available judgements of national courts as well as ECtHR. In that way legal provision and the police power limits are being clearer. Croatian Constitutional Court (hereinafter CCCt) has declared the legitimate power and duty of state to use different investigating methods (especially in early stages of proceedings) adjusted to crime offence nature when they are difficult to discover.<sup>45</sup> Regarding application preconditions, all legal requirements should be met and the bribery simulation has to be strictly formalized otherwise the evidence collected will not be usable. This means that the written order from investigating judge along with CPC prescribed content has to exist.<sup>46</sup> The CCCt has already declared that the lack of proper order content leads to violation of two constitutional guarantees- inviolability of personal and family life and the secrecy of communication in all forms so it represents the

---

<sup>41</sup> Karas, Ž. (2011); *Prikriveni istražitelj kao dokazno sredstvo u suvremenoj kriminalistici i kaznenom postupku*, doctoral dissertation, University in Zagreb, Faculty of Law, p. 271 *et seq.*

<sup>42</sup> Heine, in Schönke, Schröder, *op. cit.* in n 35, p. 522; Jescheck, H. H.; Weigend, T. (1996), *Lehrbuch des Strafrechts*, Allgemeiner Teil, Duncker & Humblot, Berlin, p. 687, and Roxin, C. (2003), *Strafrecht*, Allgemeiner Teil, Band II, Verlag C. H. Beck, München, p. 129.

<sup>43</sup> Novoselec, Bojanić, *op. cit.* in n 36, p. 296. Some authors suggest that the decisive criterion is not focusing on the uncompleted offence. Crucial is the intention not to do harm to a protected legal interest, bearing in mind the difference between the material and the formal completion of the offence. Heine in Schönke, Schröder, *op. cit.* in n. 35, p. 526.

<sup>44</sup> Krapac, *op. cit.* in n 21, p. 330.

<sup>45</sup> U-III-1393/2007, 02 June 2010.

<sup>46</sup> County Court in Osijek has abolished the contested judgement in case that included police action of simulated bribery, since it was established that the required formal precondition-the written order from investigating judge was missing. Kž 923/2007-4, 06 March 2008.



unlawful evidence.<sup>47</sup> Croatian Supreme Court has explained the extent of the admissibility of the evidence obtained by deployment of undercover agents in criminal investigations<sup>48</sup> as well as decided in cases regarding incitement to offence.<sup>49</sup> ECtHR considers that the public interest cannot justify the use of evidence obtained as a result of police incitement, it would expose the accused to the risk of being definitely deprived of a fair trial from the outset.<sup>50</sup> Use of SIT cannot in itself infringe the right to fair trial, but on account of the risk of police incitement entailed by such techniques their use must be kept within clear limits.<sup>51</sup> Where an accused asserts that he was incited to commit an offence, the criminal court must carry out a careful examination. For the trial to be fair, within the meaning of article 6§1 of the Convention (hereinafter ECHR), all evidence obtained as a result of police incitement must be excluded.<sup>52</sup> Where the Court from given information is unable to conclude if the applicant was incited, it is essential to examine the procedure of determination in each case.<sup>53</sup> In its extensive jurisprudence on the matter, the Court established the criteria for differentiating the incitement contrary to ECHR Art 6 para 1. Examination of incitement complaints is based on two categories: substantive and procedural evaluation described in 2010.<sup>54</sup> Prior to this time, some relevant decisions were also made. In *Khudobin v. Russia* case contained certain prima facie evidence of entrapment. The applicant had no criminal record prior to his arrest. Police operation had to be properly authorised and supervised, but was authorised by a simple administrative decision of a body that later carried out the operation and was not subjected to judicial review. The policemen involved in a „test buy“ were never questioned at court and ECtHR was particularly struck by the fact that applicant himself was not heard on the subject of incitement.<sup>55</sup> In *Ramanauskas v Lithuania*, police incitement was confirmed based on ex post request for authorisation of criminal conduct simulation model which was then legitimised and its results were used (privatisation of police incitement). There were no declared reasons or motives why the agents approached the applicant when he had not committed any (corruption related) offences before and all the meetings were on agent's initiative. Crucial person was never called as a witness due to the fact that he could not be traced.<sup>56</sup> In *Teixeira de Castro v Portugal*, it was confirmed that police officers have stepped outside of allowed limits since their activity was not established and supervised by court, there was no reason for initial suspect since the accused was never prior investigated or convicted and the predisposition to commit an offence was never proved.<sup>57</sup> Recently, in case *Matanović v Croatia*<sup>58</sup> applicant claimed,

---

<sup>47</sup> The inspector of Ministry of Finances was found guilty for receiving a bribe and documents forgery and contested the legality of investigating judge order regarding its content. Decision U-III-857/2008, 01 October 2008. Also, there is interesting decision of this Court regarding the use of undercover investigator in cooperation with other countries U-III-1393/2007, 02 June 2010.

<sup>48</sup> The results of the [application of special criminal investigations] have the power of evidence only if the law expressly stipulates it, but even then, as well all other evidence, must comply with the [permissibility] rules evidence referred to in Article 9 of the Code of Criminal Procedure. Kž-529 / 04-3 of 24 June 2004

<sup>49</sup> For example, I Kž-429/03-7, 2 September 2003; I Kž 37/02-7, 23 November 2005. The simulated purchase requires the undercover agent first to declare himself as a buyer of a particular type along with a price deal. It does not mean that he has incited a person to commit a criminal offense ...The incitement can exist if undercover agent without persons prior decision persistently persuaded [the accused] to commit the act (or to confirm him in such initial decision brought by the accused).

<sup>50</sup> *Teixeira de Castro v Portugal*, App no 25829/9418, 9 June 1998, §36, *Ramanauskas, op. cit.* in n 1, §54, *Khudobin v Russia*, App no 5969/00, 26 October 2006 § 128.

<sup>51</sup> *Ramanauskas, op. cit.* in n 1, §§ 50-51.

<sup>52</sup> *Ibid.*, § 60.

<sup>53</sup> *Ibid.*, § 61, *Edwards and Lewis v United Kingdom*, app no 39647/98 and 40461/98, 29 July 2003 §46 B.

<sup>54</sup> The relevant criteria that determine the Court's examination in this context are described in *Bannikova v Russia* case, app no 18757/06, §§37-65, 4 November 2010. Substantive evaluation is aimed at the question would the criminal act be committed without state intervention (passive investigation) which includes reasons for the secret operation (in particular objective doubts that person was involved in criminal activity or had a tendency to the perpetration of a criminal offense). Procedural evaluation is aimed at the manner in which the domestic courts solved the complaint of incitement.

<sup>55</sup> *Khudobin, op. cit.* in n 50.

<sup>56</sup> *Ramanauskas, op. cit.* in n 1, §72

<sup>57</sup> *Teixeira, op. cit.* in n 50.

<sup>58</sup> *Matanović v Croatia*, app no 2742/12, 04 April 2017.

inter alia, that he was incited to commit an offence which violated §6/1 of ECHR, but the ECtHR after careful examination of facts and through substantive and procedural evaluation test, did not confirmed this violation.

#### 4. CONCLUDING REMARKS

In the overall corruption suppression system, criminal law has an irreplaceable role although it appears as ultima ratio. Some of criminal procedure mechanisms are suitable for ensuring the successful processing of corruptive practices. In particular, due to the inefficiency of traditional methods, SIT of undercover agents and simulations of bribe offering and receiving are used. Given that both of these measures are significantly "threatening" for the area of human rights and freedoms (especially for fair trial right in accordance with Art. 6/1 ECHR), the substantive and formal requirements for imposing them are more stringent compared to other special measures. An important issue that arises is the delineation between the legal and illegal activities (incitement) of the undercover investigator. As a guideline demarcation, serve two criteria: the intention making process and orientation to a certain stage (attempt) of a criminal offence. Since the detection of a "subjective sphere" of an intention to commit an offence can often be complicated and even counter-productive, the orientation at the stage of attempt can serve as an additional criterion in general. There are established assessment standards since these questions have appeared in national and European courts. In its extensive jurisprudence, ECtHR has developed specific evaluation test, which includes substantive and procedural part and contains guidelines for so-called passive investigation examination. Nevertheless, we must conclude that the careful assessment of circumstances in concreto has the irreplaceable key role from case to case given the specific nature of corruption cases. Therefore, factors like offence nature, reason of particular police operation, nature and extent police participation in crime, possibility of using other methods have to be considered.

#### LITERATURE:

1. Act on Ratification of the UN Convention against Corruption on 04 February 2005, Official Gazette-International Agreements 2/2005.
2. *Adult Perpetrators of Criminal Offences, Reports, Accusations and Convictions* (2018), Statistical Reports, Croatian Bureau of Statistics, Zagreb.
3. Bannikova v. Russia, App No 18757/06, 4 November 2010.
4. Constitution of Republic of Croatia, Official Gazette, 56/1990, 135/1997, 113/2000, 28/2001, 76/2010, 5/2014.
5. Criminal Code, Official Gazette 125/2011; 144/2012, 56/2015, 61/2015, 101/2017.
6. Criminal Law Convention on Corruption, ETS No 173.  
<https://www.coe.int/en/web/conventions/full-list/-/conventions/treaty/173>
7. Criminal Procedure Code, Official Gazette 152/2008, 76/2009, 80/2011, 91/2012, 143/2012, 56/2013, 145/2013, 152/2014, 70/2017
8. Derenčinović D. (1999). *Kaznenopravni aspekti korupcije s elementom inozemnosti* Hrvatski ljetopis za kazneno pravo i praksu Vol 6, No 1.
9. Derenčinović D. (2003). *O usklađivanju hrvatskog kaznenog zakonodavstva s pravnom stečevinom Europske unije na području pravosuđa i unutarnjih poslova-korupcija i terorizam*, Hrvatska pravna revija, Vol 3, No 6.
10. Derenčinović, D. (2001). *Mit(o) korupciji*, Nocci, Zagreb.
11. Derenčinović, D. (2008). *Prilog raspravi o rasvjetljavanju velike „tamne brojke“ kod korupcijskih kaznenih djela* in Mlinarević, M. (ed), *Korupcija-pojavni oblici i mjere za suzbijanje*, Inženjerski biro, Zagreb, 2008.
12. Derenčinović, D. (2013). in Derenčinović, D. (ed.): *Posebni dio kaznenog prava* Pravni fakultet Sveučilišta u Zagrebu.

13. Edwards and Lewis v United Kingdom, App No 39647/98 and 40461/98 22 July 2003.
14. Greco, Third Evaluation Round, Compliance Report on Croatia, Incriminations (ETS 173 and 191, GPC 2), recommendations iv. and v. (§22-§29), available <https://www.coe.int/en/web/greco/evaluations/croatia>
15. Heine, G. (2010). in Schönke, A.; Schröder, H. (eds), *Strafgesetzbuch Kommentar*, 28. Auflage, Verlag C. H. Beck, München.
16. Herceg, B.; Kóhalmi, L. (2012). *Fight against Corruption in Hungary and Croatia* in Drinocsi, T.; Župan, M.; Ercsay, Z.; Vinković, M. (eds): Contemporary Legal Challenges: EU- Hungary-Croatia, Osijek- Pecs.
17. Horvatić, Ž. et al (2002). *Rječnik kaznenog prava*, Masmedia, Zagreb.
18. House of Lords, Regina v. Looseley [2001] UKHL 53, 25 October 2001, <https://publications.parliament.uk/pa/ld200102/ldjudgmt/jd011025/loose-1.htm>
19. <https://wcd.coe.int/ViewDoc.jsp?id=849269&BackColorInternet=9999CC&BackColorIntranet=FFBB55&BackColorLogged=FFAC75>
20. I Kž 37/02-7, 23 November 2005.
21. I Kž.Us 102/14-4, 3 September 2014.
22. I Kž-429/03-7, 2 September 2003.
23. I Kž-Us 147/2017-4, 7 December 2017.
24. I Kž-Us 165/15-4, 11 January 2016.
25. Jescheck, H.H.; Weigend, T. (1996). *Lehrbuch des Strafrechts, Allgemeiner Teil*, 5th edition, Duncker & Humblot, Berlin.
26. Karas, Ž. (2011). *Prikriveni istražitelj kao dokazno sredstvo u suvremenoj kriminalistici i kaznenom postupku*, doctoral dissertation, Pravni fakultet Sveučilišta u Zagrebu.
27. Khudobin v Russia, App no 5969/00, 26 October 2006
28. Kóhalmi L.(2010). *Büntetőjogi eszközök a politikai korrupció elleni küzdelemben* in Ferenc, C.; Horváth, C.; Politika és korrupció – A törvényesség és a törvénytelenység határai. Konferenciakötet, Conference Volume. Pécsi Tudományegyetem Állam-és Jogtudományi Kar, PTE ÁJK Politikatudományi és Társadalomelméleti Tanszék, Pécs-Baranyai Értelmiségi Egyesület.
29. Kralj, T.; Dragičević Prtenjača, M. (2010). *Korupcijska kaznena djela protiv službene dužnosti-s analizom prijedloga njihovih izmjena*, Hrvatski ljetopis za kazneno pravo i praksu, , Vol. 17, No. 2.
30. Krapac, D. (2014). *Kazneno procesno pravo, prva knjiga: Institucije*, Official Gazette, Zagreb.
31. Kž 923/2007-4, 06 March 2008.
32. Kž-529 / 04-3 of 24 June 2004
33. Novoselec, P.; Bojanić, I. (2013). *Opći dio kaznenog prava*, Pravni fakultet Sveučilišta u Zagrebu.
34. Pavišić, B. (2011). *Komentar Zakona o kaznenom postupku*, Dušević and Kršovnik, Rijeka.
35. Ramanuskas v. Lithuania, App. no. 74420/01, 5 February 2008
36. Recommendation R (81) 12 (on economic crime) and R (01) 11 (on guidelines for the fight against organized crime).
37. Roxin, C. (2003). *Strafrecht, Allgemeiner Teil, Band II*, Verlag C. H. Beck, München.
38. Su-IVk-4 / 2012-57, 27 December 2012
39. Teixeira de Castro v Portugal, App. No. 25829/9418, 18 May 1998
40. Turković, K., et. al. (2013). *Komentar Kaznenog zakona*, Official Gazette.
41. U-III-1393/2007, 02 June 2010.
42. U-III-857/2008, 01 October 2008
43. United Nations Convention against Corruption, [https://www.unodc.org/documents/brussels/UN\\_Convention\\_Against\\_Corruption.pdf](https://www.unodc.org/documents/brussels/UN_Convention_Against_Corruption.pdf)

## **GEO-ECONOMICS TO FIGHT AGAINST HUNGER IN AFRICA: WHAT ROLE FOR EMERGING COUNTRIES?**

**Abdelhamid Nechad**

*Professor at Abdelmalek Essaadi University, Morocco*

**Mohammed Ezznati**

*Professor at Abdelmalek Essaadi University, Morocco*

**Taoufik Daghri**

*Professor at Mohammed V University, Morocco*

### **ABSTRACT**

*The food crisis of 2008 with its food riots that have undermined the development efforts of many African countries has once again put the agricultural issue at the center of international concerns. The China-India-Africa triangle is now in the midst of this great break in the early 21st century. The question that arises at this level is the following: Can we feed a growing world population with changing diet in emerging markets and simultaneously distribute the commodity's global and combating undernourishment that affects nearly one billion people? Given their weight, both in terms of supply and demand, La Chiniafrique is now at the center of the response. Our communication is split into two parts. A first portion that is descriptive of the threat that weighs on food security in the world and the role of China and India in this reversal of the situation. The second part seeks to highlight the measures to be taken by Chindiafrique to overcome this situation.*

**Keywords:** *Geo-Economics, Hunger, Africa, Emerging Countries, Food crisis*

### **1. GEOGRAPHY OF HUNGER IN AFRICA**

Access to food is the most absolute right for every human being, yet this right remains the most heavily violated on our planet since the estimates of the United Nations Food and Agriculture Organization (FAO) show that the number of severely undernourished people on the planet amounted in 2014 to 925 million against 1023 million in 2009. Nearly 1 billion people are suffering from constant hunger. Food is the life energy of man; it can be measured by kilocalories (1 kilocalorie = 1000 calories) or the unit measuring the energy intake of food. Calorie needs differ depending on age, indeed the World Health Organization (WHO) sets at 2200 calories per day the minimum vital for an adult to reproduce its own strength. Severe undernutrition causes acute suffering that slowly destroys the body but also the psyche. It means "social marginalization, loss of economic autonomy and automatically unemployment since the person is unable to perform regular work" (Briend 1985, p.72). It inevitably leads to death. In a large number of cases, under-nourishment causes so-called hunger diseases that affect children most often: "named him, kwashiorkor, etc. In addition, it dangerously weakens the immune defenses of its victims" (Ibid, p.73). In order to better understand the geo-economics of hunger, two categories should be distinguished: "structural hunger »And« cyclical hunger ". As indicated by his name, "structural hunger" Means physical and psychic destruction. It is permanent, not very spectacular and reproduces itself biologically. As for cyclical hunger, it only happens again when a natural disaster (drought, floods, etc.) or a war tears apart the social fabric or ruins the economy. Who are the most exposed to hunger? The three largest categories exposed to mass destruction are, according to FAO, the rural poor, the urban poor and the victims of the disasters already mentioned. The rural poor: "are people from poor rural communities in the South without clean water or electricity.

In these regions, the public health education and hygiene services are non-existent, this community represents half of the population " (Ibid, p.132). The urban poor: " are people from poor urban communities who are content with extremely limited income. The World Bank estimates that 1.2 billion extremely poor people living on less than \$ 1.25 a day " (Ibid, 133). Indeed, the geographical distribution of hunger in the world is extremely unequal since "the underdeveloped countries are the most affected with a high rate in the Asia Pacific followed by Sub-Saharan Africa then Latin America, the Near East and North Africa and finally the developed countries " (The great and Tchagneno, 2014, p.78). Thus, the demographic evolution associated with soaring prices on the rise increase the disaster of undernourishment in the world. While the number of people suffering the most from this scourge belongs to developing countries with a remarkable annual evolution (30% in 2010 in sub-Saharan Africa), the developed countries, for their part, do not escape the specter of hunger with 9 million people gravely and permanently undernourished. In addition to undernourishment, there is another phenomenon called malnutrition that FAO does not consider as a destructive weapon of the suffering population. Malnutrition is due to " a permanent and serious deficiency of vitamins and minerals essential to the human body, these nutrients are not manufactured by the body and must imperatively be provided by a varied diet, balanced and of good quality. It usually affects children between 0 and 5 years old " (Agbessi and Damon, 2009, p.209). Contrary to the effects of undernourishment, the effects of malnutrition are not immediately visible, which leads to a very high vulnerability to infectious diseases and then death. The United Nations refers to malnutrition as " silent hunger » Or « silent hunger "Jean Ziegler calls" invisible hunger Since we do not see it, if we take for example a child affected by malnutrition: he has a weight and curves that look exactly like his age when in reality he is lacking in calories that can lead to agony, anemia and death. FAO does not take into account the harmful effects of malnutrition and does not even count them, so several other organizations are conducting statistics at this level, such as the Micronutrients Initiative, a non-profit organization that periodically surveys whose results are published in reports entitled " Vitamin and mineral deficiencies: Global evaluation ". It therefore appears that one-third of the world's population can not realize its physical and intellectual potential because of vitamin and mineral deficiencies. In the world, every four minutes, a human being loses sight, due to a lack of food. Malnutrition causes several serious diseases; so " lack of Vitamin A causes blindness (40 million children suffer), prolonged lack of vitamin B causes beriberi, lack of vitamin C causes scurvy or rickets, lack of iodine causes goiters, severe growth disorders, lack of zinc affects motor and brain faculties " (Agbessi-Dos and Damon, 2009, p122). Let's not forget that malnutrition also affects the psychological side of the person. Like malnutrition, malnutrition generally affects children in underdeveloped countries living mainly in sub-Saharan Africa. However, the authorities rarely intervene by putting in place some treatments to reduce the percentage of children suffering from malnutrition. Conversely, there is currently a rush to green gold (very greedy culture by nature) under the pretext of preserving the environment and fight against global warming.

## **2. THE MALEDICTION OF BIOFUELS**

In recent years, green gold has become a magical and profitable supplement to oil. The agro-food trusts that dominate the manufacture and trade of agro-fuels are advancing because the substitution of plant energy for its fossil sister would be the absolute weapon in the fight against climate degradation and the irreversible damage it causes. on the environment and the human being. Climate degradation is' "a reality on a global scale since it affects 1 billion people in more than 100 countries " (Libaert and Tguerin, 2008, p.53). In the countries of Africa, arid lands are overcrowded with 325 000 people thing that directly causes soil degradation. The consequences of land degradation are particularly serious where millions of people depend entirely on land to survive as peasants or pastoralists and where there are no livelihoods.

The destruction of ecosystems and the degradation of agricultural areas are " a tragedy for the poor, the UN has about 25 million ecological refugees " or " environmental emigrants " " (Ibid., P. 62), that is to say people who were forced to leave their homes because of natural disasters. In Africa, these disasters also generate conflicts between nomads and farmers for access to resources. The transnational agro- fuel companies have been able to convince most of the public and almost all Western governments that energy is the magic weapon against climate degradation. But their argument is false since the production of ag ro- fuels requires water and energy knowing that drinking water is becoming increasingly scarce in sub-Saharan Africa and many diseases are caused due to poor water quality. From the point of view of water reserves on the planet, the production of tens of billions of liters of agro- fuel is a real catastrophe. Multinational companies of US origin are the world's leading biofuel manufacturers, they are powerful and receive grants of government aid. Barack Obama considered the bioethanol and biodiesel program a cause of national security. It is widely accepted that burning millions of tons of food on a planet where every five seconds a child under 6 dies of hunger is an act of great violence. In other words, the tank of a mid-size car running on bioethanol contains 50 liters, to make these 50 liters it is necessary to destroy 358 kilograms of corn that can serve as food for one year for a Zambian child. Not only do agrofuels consume hundreds of millions of tons of wheat maize and other foods every year, they also cause social disasters in the countries where the transcontinental societies that make them become dominant. The example of Brazil is striking. In Brazil, the production program of agrofuels has absolute priority and sugar cane is one of the most profitable commodities for the production of bioethanol. The Pro-Alcohol Plan is the name of the Brazilian program that aims to increase bioethanol production, this program is the pride of the government (Zammit, 2012, p.69). The government of Brasilia would bring to 26 million hectares planted with sugarcane. The implementation of the Brazilian Pro-Alcohol Plan has led to the rapid concentration of land in the hands of a few indigenous barons and transcontinental societies. This movement of concentration is obviously taking place at the expense of small and medium-sized family farms. This reorientation of agriculture towards a purely capitalist monopolistic model left on the side of the road those who could not afford to equip themselves with machinery, to buy inputs, land ... and so to launching intensive cane cultivation, which resulted in the disappearance of 941,111 small and medium-sized farms in Brazil and the expulsion of 5.4 million peasants. These monopolies exacerbate inequalities, causing rural poverty but also urban poverty (as a result of the rural exodus) and thus jeopardize the country's food security. In addition to these inequities, the Pro-Alcohol program benefits large foreign transcontinental corporations, including Louis Dreyfus, Bunge, Noble Group, Archer Daniels Midland, Bill Gates, George Soros and China's sovereigns, and this only deepens with the signing of an agreement allowing China and the State to open, by 2019, twenty ethanol plants in the Recôncavo. In a country like Brazil, where millions of people claim the right to food, or land grabbing by transcontinental societies and sovereign wealth funds, this is an additional scandal. At the Human Rights Council, at the UN General Assembly Paolo Vanucci [1] and Lula argued their position by the fact that the cane is not edible, the Brazilians do not burn corn or wheat. This argument is not admissible since the agricultural frontier is constantly moving: the cane moves inland to the continental shelf and the cattle migrate west and north. To the extent that Brazil has gradually substituted sugar cane for food crops, there has been a direct increase in food prices and thus food insecurity. Cane cutters in Brazil suffer from practices close to slavery before 1883 despite the difficulty of the work done. The transcontinental societies prefer to employ migrants who allow them to save social security contributions and reduce production costs in a disadvantaged working environment (schedules, conditions, infrastructure). Thus, the consequences of this work remain disastrous on the health of the workers and sometimes cause their death. We therefore deduce that monoculture has ruined Brazil, today it is back.

The curse of sugar cane again hits Brazil! In Africa: In Angola, specifically, the government announces plans for 500,000 hectares of land for agrofuels, and a Portuguese firm plans to grow sunflower, soybean and jatropha in the province of Cunene. export crops in Europe so that they are transformed into agro- fuel, since 2009 it has produced agro diesel on 13 000 hectares and plans to expand existing palm plantations to produce agrofuels. In Cameroon, the Cameroonian palm grove company is partially owned by a French group that announces its intention to increase palm oil production. In 2000, the French group signed a 60-year lease on 58,000 hectares. In the Democratic Republic of the Congo are announced the largest projects in the field of agrofuels, two companies are responsible: one Chinese, who would invest 1 billion dollars in a plantation of 3 hectares of palm, and the other Italian who would plant 70 000 million. In Ethiopia, 8420 local and foreign investors have received permits to develop sugarcane farms. In Kenya, Japanese, Canadian and Belgian companies were planting and growing jatropha. In 2008, the president signed a contract with a transcontinental company to sell 1 million hectares of arable land for oil palm plantation and bioethanol production but the contract was canceled by the president's successor after having chased him away. Sierra Leone is one of the poorest countries in the world (according to the UNDP 2014 Human Development Index), which has just emerged from an eleven-year civil war, almost 80% of the population lives in extreme poverty with high levels of undernourishment. A transcontinental company headquartered in Switzerland has just acquired a concession of 20 000 hectares of fertile land for planting sugarcane and thus producing bioethanol for the European market, these projects are jointly financed by the African Development Bank and the European Development Bank, whose ultimate goal is to destroy peasant life. African. This project only worsens the situation of the inhabitants by drowning them still in permanent despair. Agro-fuels cause social and climate disasters, destroy food crops and worsen world hunger in a planet where every five seconds a child under 10 dies of hunger, divert food lands and food to produce fuels constituting a crime against humanity.

### **3. THE ROLE OF EMERGING COUNTRIES (CHINA AND INDIA)**

Confronted with their major challenges - feeding middle classes in the middle of a food transition in Chindia, but also hundreds of millions of poor people in Africa and those threatened by the advance of sugar cane and Jatropha, the two Asian giants are forced to play the map of the globalized productivist model. They rely on the continents for abundant available land: Africa and Latin America. In the latter, it is particularly Brazil, which is positioned as one of the great agricultural powers of the twenty-first century, but also of Argentina, which probably has the highest per capita stock of arable land on the planet and courted by China for this purpose, especially for the feeding of animals. We find especially the China-India-Africa triangle which is far from being an imaginary or mainly geopolitical triangle. Already, Chinese and Indian firms are investing heavily in African agriculture through land purchase. They are in competition with a large zone importing agricultural products: The Middle East, which lacks water and land, even as its population continues to grow rapidly. The Gulf countries are thus the first land investors in Africa, where they reinvest a growing share of their oil revenue. It is understandable in this context that the proponents of the productivist model emphasize the promotion of commercial agriculture in Africa. The OECD Development Center has thus dedicated an entire working group in 2008 emphasizing two attractive factors. [1]. On the demand side, writes the OECD, " the rise of China and India represents a new and potentially very significant opportunity for African agricultural exports ... The rapid growth of the incomes of these two giants is likely to cause an explosion in their food demand, although their agricultural imports from Have grown rapidly in recent years, China and India still account for only 7% of African agricultural exports ". On the supply side, the OECD emphasizes the role of multinationals in the sector, as they are able to manage the transition towards a globalization

of African agriculture. Of the forty-nine firms in the Fortune 500 sector, twenty-five were already operating in Africa, mostly concentrated in the North and South. All are now expanding on the African continent. Africa has indeed enough to attract these private operations it has the largest land reserves on the planet and a considerable under-population density in comparison with that of Asia. Remember that Africa is as vast as China, India, Europe and the United States together! The difference is that it does not have strong sovereign political structures like in Brazil, so that are foreign operators who come today to develop its agricultural potential, especially the Asian giants, in own or via companies of Malaysia and Singapore. The Ivorian company SIFCA and its Singaporean partners Olam and Wilmar have earmarked more than 20 million euros for the construction of a new palm oil refinery in Abidjan, the largest on the continent. Officially, it is a question of offsetting West Africa's oil deficit, which is nearly 800,000 tonnes today, but clearly also of exporting to China. Olam is present throughout the sub-continent with sugar refineries in Nigeria, as well as mills in Nigeria and Ghana. In Gabon, the Singaporean group plans to plant some 200,000 hectares of palm trees by 2014, for an annual production of 1 million tonnes of palm oil. Whether the calendar or not, the partnership of Gabon with China has strengthened significantly in 2010, with the visit of Beijing President Ali Bongo Ondimba. On the Indian side, Prime Minister Manmohan Singh's visit to Addis Ababa in the spring of 2011 for the second India-Africa summit, showed India's keen interest in agricultural projects in Africa, particularly in Ethiopia. It is already the largest foreign investor in the country, with projects totaling \$ 4.4 billion, almost half of them in commercial agriculture. The emblem in this area is the Karuturi Global Group, the world's leading producer of roses, headquartered in Bangalore. The Indian group acquired 300,000 hectares in Ethiopia in Gambela in 2009, after buying 1,1700 hectares in Bako the previous year. He cultivates cereals and palm oil on the spot, on an area representing nearly seven times the city of Mumbai! And the family conglomerate does not hide its ambitions: win one twentieth of the world rice market, playing on the reputation of basmati rice, native of India. In fact, he is far from being the only Indian entrepreneur in a country where renting land costs about \$ 2 per year per hectare, compared with nearly \$ 400 in India!

*Table 1: Estimated farmland exploited and available in 2005.*

	Areas cultivated in 2005	Balance of arable land	Total arable land	% already operated	% world balance not exploited
Asia	466	120	586	79%	5%
Afr.sub-Saharan	209	209	1031	20%	31%
Afr. North / Middle East	92	7	99	93%	0%
Am. Latine	170	896	1066	16%	34%
OECD	372	502	874	43%	19%
Eastern country	213	284	497	43%	11%
<b>Total World</b>	<b>1521</b>	<b>2632</b>	<b>4153</b>	<b>37%</b>	<b>100%</b>

*Source : FAO 2010*

Yet China and India can also play a major role in taking off Africa's sustainable agriculture and focusing on the continent's food needs. First, by choosing themselves less extensive and greener agricultural policies. Moreover, these countries-continent do not hide their reluctance and worries about a globalized model of agriculture that would make them too dependent on



external food powers, threatening their security. The bitter experience of American food aid in the 1960s is still in the minds of most current leaders. They therefore intend to give priority to their food self-sufficiency. And acquiring agricultural land in Africa or Latin America is ultimately a lesser evil for Chindia, compared to a dependence on large global firms or American and European powers. Chindia also relies on its agronomic research, particularly on biotechnologies, to increase yields and optimize agrosystems threatened by water shortages, land degradation or climate change, not to mention the temptation to develop in both regions. countries, biofuels, to reduce their considerable energy dependence, officially the least possible at the expense of food crops but this is often a wishful thinking, as we see in India, with the proliferation of jatropha plantations. This highly productive plant in oil was supposed to be exploited only on uncultivated surfaces. 11 million hectares have been selected by the Indian government with the goal that by 2020 biofuels will satisfy one-fifth of the country's total consumption. In reality, yields are such that jatropha does encroach on food lands, especially those of small farmers. The agronomic progress made by the two Asian giants could, obviously, benefit Africa. Including in a field such as meteorological satellites, designated by India as an axis of privileged cooperation, at the summit of Addis Ababa. In the same way, Delhi can give small African farms the benefit of its know-how in microfinance, a major tool for accessing credit and getting out of farming. Jean-Yves Carfantan shows himself all the interest of this financial instrument for Africa, through the example of Madagascar, which provides half of the global production of vanilla. In addition to large estates, cooperative groups of more than 10,000 members in total have established a network of rural credit associations on site, which gives small producers access to basic financial services. Cooperation with major Indian microfinance networks is growing rapidly today. Basix, one of the first Indian microfinance networks, based in Hyderabad, receives each year several dozen heads of African NGOs, including Nigeria, who come to train in sophisticated techniques to reduce the costs of administration and transaction. its millions of beneficiaries. Another area is still sometimes a taboo subject, especially in Europe: GMOs, of which India and China are gradually becoming pioneers, alongside some major transnational companies, objects of criticism, such as Monsanto. There are actually three problems with these genetically modified organisms. Current research is primarily directed towards the interests of large farms and some major cash crops such as soybean, rapeseed, maize or cotton. However, it should be possible to develop research for small rural communities and food crops, with their infinite local varieties. The second problem is legal and patent-related, which makes seeds more expensive and further marginalizes small farmers who can not pay the required royalties. Finally, there is the ecological question, concerning the danger of a drastic reduction of biodiversity and the long-term effects of GMOs on health, as well as on ecosystems, because of the risks of contamination of conventional crops. However, it is difficult to brush aside what GMOs can bring, first and foremost to Chindiafrique. Some varieties of genetically modified plants produce their own insecticide, such as transgenic maize bt ". Field experiments have also resulted in rice varieties resistant to insects, diseases or floods. In China, for example, yields have been much higher than conventional varieties with one fifth of the usual amount of pesticides used, and vitamin enriched rice has been created to compensate for the frequent deficiencies affecting hundreds of thousands of people. Africa. Asia has not yet paradoxically reached 3000 calories on average, but it comes from afar: less than 2,000 calories per capita in 1960, less than then! According to the FAO, the average ration in Asia could exceed 3,600 calories per day by 2050, which would imply a scenario of convergence with the western standard. In fact, the assessment of food demand is much more complex than we think. It is enough to convince oneself of comparing the ten estimates available today and very well synthesized in an analysis note from the Center for Studies and Foresight of the French Ministry of Agriculture. On the one hand, the demand for food expressed in kilocalories per day (kcal / d) could increase by 68% simply by extending

the current trends and we find the scenario of the FAO. On the other hand, the scenario of "trend disruption" Agrimonde estimates that it could grow by only 40%, not far from the 44% of the scenario of the Vienna Institute "The meat but fair" (« Less meat but egalitarian »). Where do these differences come from? On the population side, all the organizations rely on the median projections of the UN: with a progression of 43% by 2050. Only a scenario of the Institute of agronomic research IFPRI adopts the low range of the experts of the UN, that of an accelerated demographic transition and a population progressing only 26%. But the institute paradoxically leads to a 64% growth of the food demand, under the effect of a faster convergence of wealth levels between the different countries of the planet, with a growth in income and therefore the demand for food faster in the South and even a possible disappearance of malnutrition. This shows that the population is far from the number one problem. After demography, the second step is to estimate the evolution of the average individual food demand by making projections by continent according to the expected growth of incomes and by assuming eating behaviors identical to those of the North. The projections then lead to a 30% increase in demand per capita. On the other hand, in the agrimonde and the Vienna Institute scenarios, which test the hypothesis of another way of consuming - less and better - the world food demand and almost stabilized. Third step: one refines by looking at what could be the evolution of the individual demand of products of animal origin. It takes the equivalent of 10 tons of cereals to obtain one caloric ton of meat (the factor is 15, in the case of beef). The range of forecasts of the experts expands considerably here since one reaches a peak of +78% of the individual consumption of meat in the trend scenario, but +40% only in that of the FAO and ... -21% in that of the institute of Vienna, which tests a scenario of 360 kilocalories of meat a day, against 500 on average currently. We are far from a pure vegetarian scenario on a global scale, but the impact is striking. In this case, and under the assumption of a greater equity in food distribution that would eliminate all the malnutrition on the planet, a growth of 45% of the current food production would be enough to feed 9 billions of human beings. In the case of a full vegetarian scenario, current production would be sufficient! But who wants today a communist model, even green? However, on a strictly energy level, the net need of the individuals is estimated by the nutritionists between 2000 and 3000 kcal / day according to the sex, the age, the weight and the intensity of the physical activity. In the world, the availability of food has increased from 2500 kcal / d in 1961 to 3000 in 2003. The whole problem would not it be a simple question of distribution and food habit? Why take the risk of a doubling of world food production, with an unlimited extension of cultivated areas, including a growing part dedicated to livestock, and pushing yields ever higher, consuming more water, fertilizer and pesticides? In the opinion of most specialists, such as André Lebeau, humanity would risk crossing irreversible thresholds of non-renewal of water and biomass resources. As with global economic production, where greenhouse gas emissions can not be envisaged, as Tim Jackson suggests, a model of reasoned increase in production in developing countries that need and play the control of production and consumption in rich countries, with a convergence over time around an individual consumption of 3000 kilocalories / day. The increase in world agricultural production needed would therefore be only one-third, according to Agrimonde, while it should almost double in the trend scenario. Western countries or Japan do not have the prerogative of ostentation in food. In China, it is customary to offer shark fins or sea cucumbers (trepan or sea cucumber) at around 500 euros per kilo in the chicest restaurants. This last dish was displayed in the window at the top of the pavilion of culture, at the 2010 Shanghai World Expo. Its consumption dates back to the Song Dynasty (960-1280 AD), a booming luxury boom. This competitor of Western caviar-champagne reminds that the global competition also relates to food standards and the social image. And, as the WorldWatch Institute writes in its 2010 report: to move from conspicuous consumerism to the sustainability of the planet, we must also transform cultures and not just agriculture! It is an area where cultural change is likely to prevail: Climate change.

The FAO 2050 report is unambiguous here. Available studies show that the only impact on Africa of lower yields and extreme weather events is expected to be 15 to 30% of production by 2080-2100. In India, the increasing climate change is already having an impact every year, with more than half of the land still irrigated. As for China, the drought is gaining more and more ground despite massive reforestation campaigns as in the north of the country and while three quarters of irrigable areas are already. This is an area where the evolution of political power plays a clear role in the next few years. As we can see, the food question of the New World is much less of a question of need than of power. The one who eats the most and who produces the most, including exportable surpluses, is the one with the world food power, both in terms of safety or insecurity, and in terms of consumption standards.

#### LITERATURE:

1. AGBESSI-DOS SANTOS Hélène, DAMON Michel (2009), *Manuel de nutrition africaine : Eléments de base appliqués*, Paris, Karthala
2. AGGERI Franck (2005), *Organiser le développement durable: Expériences des entreprises pionnières et formation de règles d'action collective*, Paris, Vuibert
3. BRIEND André (1985), *Prévention et traitement de la malnutrition: Guide pratique*, Paris, L'Orstom
4. CARROUE Laurent, COLLET Didier, RUIZ Claude (2007), *La Mondialisation*, Paris, Bréal
5. CHAUTARD Sophie (2006), *Comprendre la géopolitique*, Paris, Studyrama
6. FERGUSON Niall (2004), *Empire: How Britain Made the Modern World*, Londres, Penguin books
7. FODOUAP Kengne et TAPE BIDI Jean (2010), *L'armature du développement en Afrique: industries, transports et communication*, Paris, Karthala
8. JARED Diamond (2013), *Guns, germs and steel*, New York, Random house
9. LANDES David (1999), *The wealth and poverty of Nations*, Limoges, Abacus
10. LE GRAND Charles, TCHAGNENO Téné (2014), *Le Développement en Afrique: Problèmes et perspectives de solutions*, Paris, Publibook
11. LIBAERT Thierry, GUERIN André-Jean (2008), *Le développement durable*, Paris, Dunod
12. MAX Weber (1964), *L'éthique protestante et l'esprit du capitalisme*, Paris, Librairie Plon
13. MBANDZA Joseph (2004), *Pauvreté et modèles de croissance en Afrique subsaharienne*, Paris, Publibook
14. MFENJOU Nji Modeste Chouaïbou (2002), *L'Afrique à l'épreuve du développement durable*, Paris, l'Harmattan
15. MOUANDJO LEWIS Pierre (2002), *Facteurs de développement en Afrique : L'économie politique de l'Afrique au XXIe siècle*, Paris, l'Harmattan
16. RODRIK Dani (2003), *In searsh of prosperity*, New Jersey, Princeton University Press
17. RAGHAVAN C (1991), *Recolonisation : l'avenir du tiers-monde et les négociations commerciales du GAIT*, Paris, L'Harmattan
18. SADIGH Elie (2002), *Etude économique et géopolitique du développement : le sous-développement n'est pas une fatalité*, Paris, L'Harmattan
19. TETE-ADJALOGO Têtêvi Godwin (2000), *La question du plan Marshall et l'Afrique*, Paris, l'Harmattan
20. TOPPE Gilbert (2010), *L'Union Africaine et le développement de l'Afrique*, Paris, L'Harmattan
21. ZAMMIT Nasser (2012), *L'Afrique et la question environnementale*, Paris, Connaissance et savoirs
22. ZIEGLER Jean (2012), *Destruction massive : Géopolitique de la faim*, Paris, Seuil

23. CHARVET Jean Paul (2010), *Agriculture et alimentation : vers quels nouveaux modèles ? Les différentes agricultures durables*, Cahiers français, N°355
24. HUGON Philippe (2010), *L'économie Verte*, Cahiers français, N°355
25. COSTILLE Jean-Pierre (2012), *20 ans de développement durable*, Problèmes économiques, N°3044
26. COLLIER Paul (2006), *Africa: Geography and Growth*, Centre for the Study of African Economies, Department of Economics, Oxford University
27. LAROCLETTE Brigitte, SANCHEZ-GONZALEZ Joan (2015), *Cinquante ans de consommation alimentaire*, Problèmes économiques, N° 3120
28. SALTZMAN A., BIROL E., WIESMAN D., PRASAI N., YOHANNES Y., MENON P., THOMPSON J. (2014), *Indice de la faim dans le monde 2014 : Le défi de la faim invisible*, extrait du rapport octobre 2014 de l'Institut International de Recherche sur les Politiques Alimentaires
29. VON BRAUN Joachim, SWAMINATHAN Monkombu, et ROSEGRANT Mark (2004), *Agriculture, sécurité alimentaire, nutrition et les objectifs du millénaire*, essai extrait du rapport annuel 2003-2004 de l'Institut International de Recherche sur les Politiques Alimentaires

## THE USE OF ICT POTENTIAL IN V4 COUNTRIES

**Joanna Kos-Labedowicz**

*University of Economics in Katowice, Poland*

*joanna.kos@ue.katowice.pl*

### **ABSTRACT**

*The development of information and communication technologies (ICT) and their widespread use in various areas of life pose great challenges to both the microeconomic and macroeconomic level. Research on the impact of ICT on economic growth, efficiency, productivity, and the level of well-being more and more often draw the attention of scientists from various fields, and their results are important for decision-makers at various levels of state administration. The problem of measuring the impact of ICT on the economy is an extremely complicated issue, due to the multitude of variables and the problem with the selection of those most appropriate for that task. ICT development and its use have been regarded in the European Union for a long time as an important factor for maintaining the competitiveness of the European Union's economy, and in the longer term, the standard of living of its citizens. Despite actions taken, the use of ICT is notoriously different across the Member States. The aim of this paper is to analyse the position of V4 countries concerning the use of ICT and compare it with selected European Union Member States and other developed countries. The analysis of available indicators describing the current level of using the ICTs' potential and the selection of the most suitable ones should enable to achieve the stated aim of the article. Both literature review and analysis of statistical data were used.*

**Keywords:** *European Union, ICT potential, ICT use, V4 countries*

### **1. INTRODUCTION**

In recent years, a new trend is increasingly visible, the one concerning the growing influence of the potential use of modern technologies for maintaining the competitiveness of the European Union's economy, and in the longer term, the standard of living of its citizens. Information and communication technologies (ICTs) are a perfect example of the importance of modern technologies for economic growth, improvement in productivity and maintaining a competitive position (Vu, 2011). Increasing the use of ICT potential has been an area of interest for the European Union since the mid-1990s, as evidenced by ongoing initiatives being developed at European level by the European Commission. The Digital Agenda for Europe (DAE) is an initiative currently in force under the horizontal strategy of Europe 2020 (European Commission, 2010). Nevertheless, attention should be paid to the large diversity observed between individual Member States in terms of ICT potential utilization. It is enough to compare in this regard leading Scandinavian countries with countries of Central and Eastern Europe such as Romania or Bulgaria. At the same time the division is not as simple as between the "Old EU15" and the countries that joined after 2004. This is due to a differentiated approach among the member countries regarding the direction of activities aimed at increasing the use of ICT potential. For example, Cruz-Jesus, Oliveira and Bacao (2012) have identified two independent areas describing the diversity of member states in terms of ICT use: infrastructure and adoption by population as well as e-business and Internet access cost. Based on these two dimensions, the following five groups of countries were distinguished: digital laggards (Bulgaria and Romania), individual-side focused (Estonia, France, Hungary, Latvia and Slovenia), firm-side and low access costs focused (Cyprus, the Czech Republic, Greece and Lithuania), digital followers (Austria, Belgium, Germany, Ireland, Malta, Poland, Portugal, Slovakia, Spain and United Kingdom), digital leaders (Denmark, Finland, Luxembourg, the Netherlands and Sweden) (Cruz-Jesus, Oliveira, Bacao, 2012).

Croatia was not included in the aforementioned analysis, as it joined the EU in 2013. The aim of this paper is to analyse the position of V4 countries concerning the use of ICT and compare it with selected European Union Member States and other developed countries. Both literature review and analysis of statistical data were used. The problem of measuring the impact of ICT on the economy is an extremely complicated issue, due to the multitude of variables and the problem with the selection of those ones that will best show actual and significant dependencies (Misuraca, Codagnone, Pierre, 2013; Schlichter, Danylchenko, 2014). All the time, attempts are being made to develop new and improve existing aggregated tools to measure the impact of ICT on the economy and to identify the factors most conducive to its development (Emrouznejad, Cabanda, Gholami, 2010; Katz, Koutroimpis, Callorda, 2014). Considering the diversity in the use of ICT potential among EU members, the author decided to analyze the V4 ICT potential using two global indicators: the Networked Readiness Index (NRI) and the Global Competitiveness Index (GCI, that also includes aspects of ICT usage) as well as the Digital Economy and Society Index (DESI) measured for EU members. In order to outline a broader picture of the ICT potential of the V4 countries, the comparison was made not only within the group but also in comparison to selected well-developed economies. In the case of NRI and GCI, the V4 countries are presented against Sweden and Finland (the two best-performing EU countries in terms of ICT usage) and the USA and Japan (two traditional EU competitors in terms of ICT usage). In the case of the DESI comparison, the V4 countries have been referred only to the two EU countries (Sweden and Finland). The author has not decided to use the ICT Development Index (IDI) developed by the International Telecommunication Union (ITU) in comparison, due to the fact that the methodology of calculating this indicator includes only 11 variables (only 1 more than in the case of the 9th pillar of the GCI) and it uses different scale of values which would make it difficult to compare with the values for NRI. In this article, the chosen indicators will be analyzed in the following order: NRI, GCI, and DESI.

## **2. COMPARISON USING NETWORKED READINESS INDEX RANKING**

The NRI is currently published annually by the World Economic Forum in the "Global Technology Report". Since its creation, this indicator has been used to measure the impact that ICT has on the productivity and competitiveness of economies. This indicator has evolved since the time it was proposed for the first time. The most important changes were introduced in the 2012 report, when the decisions about changing the indexation methodology and the departure from the bi-annual cycle of report preparation were made. The new method has been based on 5 basic principles: 1) the key importance of measuring the economic and social impact of ICT, 2) the impact the environment has on achieving the potential benefits of ICT use, 3) readiness and then use of ICT are crucial to achieving its potential benefits, 4) all considered drivers/factors influence each other and are constantly changing, 5) that new methodology should translate into clear indications for the development of ICT policy (World Economic Forum, 2012). The rank and value of the NRI for the V4 countries and for selected highly developed economies (Sweden, Finland, the United States and Japan) for the years 2007-2016 are presented in Table no 1. It was decided to present both the place in the ranking and the value of the index to better illustrate the actual position concerning ICT use of the economies in question. While analyzing both this and the other two indicators, it is important to note that changes in the value of the index are more important than those of the ranking position. This is due to the fact that, firstly, the number of countries taking part in the ranking varies from year to year, and secondly, the change in the particular country's ranking position is influenced both by changes in its index score as well as by changes in other countries' index scores. Because of that, a change in ranking position may be due to a real improvement/deterioration of the particular country scores and it may be due to an improvement/deterioration of the scores for another country/countries.

As mentioned above, caution should be exercised when comparing the data before and after 2012 due to a change in the methodology for index calculation. At the time of writing the article the data for 2017 were not available due to one more change of the index preparation methodology.

*Table 1: V4 countries in the NRI ranking in comparison to selected developed countries in years 2007-2016 (Dutta, Mia, 2009, p. 10; Dutta, Mia, 2011, p. 12; Dutta, Bibloa-Osario, 2012, p. 12; Bibloa-Osario, Dutta, Lanvin, 2013, p. 11; Bibloa-Osario, Dutta, Lanvin, 2014, p. 10; Dutta, Geiger, Lanvin, 2015, p. 8; Baller, Dutta, Lanvin, 2016, p. 16)*

Country	NRI	2007-2008	2008-2009	2010-2011	2012	2013	2014	2015	2016
Sweden	Rank	2	2	1	1	3	3	3	3
	Score	5.72	5.84	5.6	5.94	5.91	5.93	5.8	5.8
Finland	Rank	6	6	3	3	1	1	2	2
	Score	5.47	5.53	5.42	5.81	5.98	6.04	6.0	6.0
United States	Rank	4	3	5	8	9	7	7	5
	Score	5.49	5.68	5.33	5.56	5.57	5.61	5.6	5.8
Japan	Rank	19	17	19	18	21	16	10	10
	Score	5.14	5.19	4.95	5.25	5.24	5.41	5.6	5.6
Czech Republic	Rank	<b>36</b>	<b>32</b>	<b>40</b>	<b>42</b>	<b>42</b>	<b>42</b>	<b>43</b>	<b>36</b>
	Score	4.33	4.53	4.27	4.33	4.38	4.49	4.5	4.7
Hungary	Rank	37	41	49	43	44	47	53	50
	Score	4.28	4.28	4.03	4.3	4.29	4.32	4.3	4.4
Poland	Rank	62	69	62	49	49	54	50	42
	Score	3.81	3.8	3.84	4.16	4.19	4.24	4.4	4.5
Slovak Republic	Rank	43	43	69	64	61	59	59	47
	Score	4.17	4.19	3.79	3.94	3.95	4.12	4.2	4.4

The potential value of the NRI index (as well as its subindexes) varies from 1.0 to 7.0 points, but even top-ranked economies (like Sweden and Finland) do not reach a value significantly higher than 6.0 points. For the V4 countries analysed, significant changes in the positions in the ranking can be observed. In the period between 2012-2016 the average shift in the ranking's position was on average around 6-7 places (for the Slovak Republic, whose position shifted most, it was as many as 17 places). Despite the changes observed in the ranking positions (both improvement and deterioration), the score of the indicator in the period 2012-2016 has increased for all V4 countries. The highest growth can be observed in the case of the Slovak Republic (0.46 points) and the lowest in the case of Hungary (0.1 points). The NRI is currently calculated on the basis of four subindexes (until 2012 only 3 subindexes were used). Each of these subindexes is further subdivided into pillars (10 in total) and specific variables (53 in total). Subindexes include both drivers and impacts of ICT on economy and society. In the drivers' category there are 3 subindexes (used in calculating the NRI index prior to 2012) – environment subindex, readiness subindex and usage subindex – and the impacts subindex (included for the first time in the 2012 report). The pillars for all subindexes are accordingly: 1) political and regulatory environment, business and innovation environment; 2) infrastructure and digital content, affordability, skills; 3) individual usage, business usage, government usage; 4) economic impacts, social impacts. Graph No 1 shows the evolution of the NRI subindex for the V4 countries in the years 2012-2016. Analysing values of subindexes allows us to indicate areas where the most significant changes occurred for each of the V4 countries. According to the aggregate value of the NRI, the Czech Republic has the best position among the V4 countries, ahead of Poland by 0.2 points and ahead by 0.3 points of Hungary and the Slovak Republic. But when considering each of the subindexes separately, a more diversified picture can be obtained. For example the value of the Readiness Subindex for Poland is close to its values for the Czech Republic (and even higher in the years 2013 and 2015).

At the same time the values of both the Impact Subindex and Usage Subindex achieved by Poland are the lowest of all V4 countries. A similar situation can be observed in the case of Hungary – despite the rather high value of the Impact Subindex, a decrease in the values of all other subindexes resulted in its overall NRI rank being the lowest of all V4 countries. The greatest improvement is evident in the case of Slovakia, for which the values of all sub-indices increased in the period analysed. Unfortunately, the changes in the way the NRI is calculated, both those introduced in 2012 and those announced for 2017, do not allow for comparisons to be made over a longer period of time.

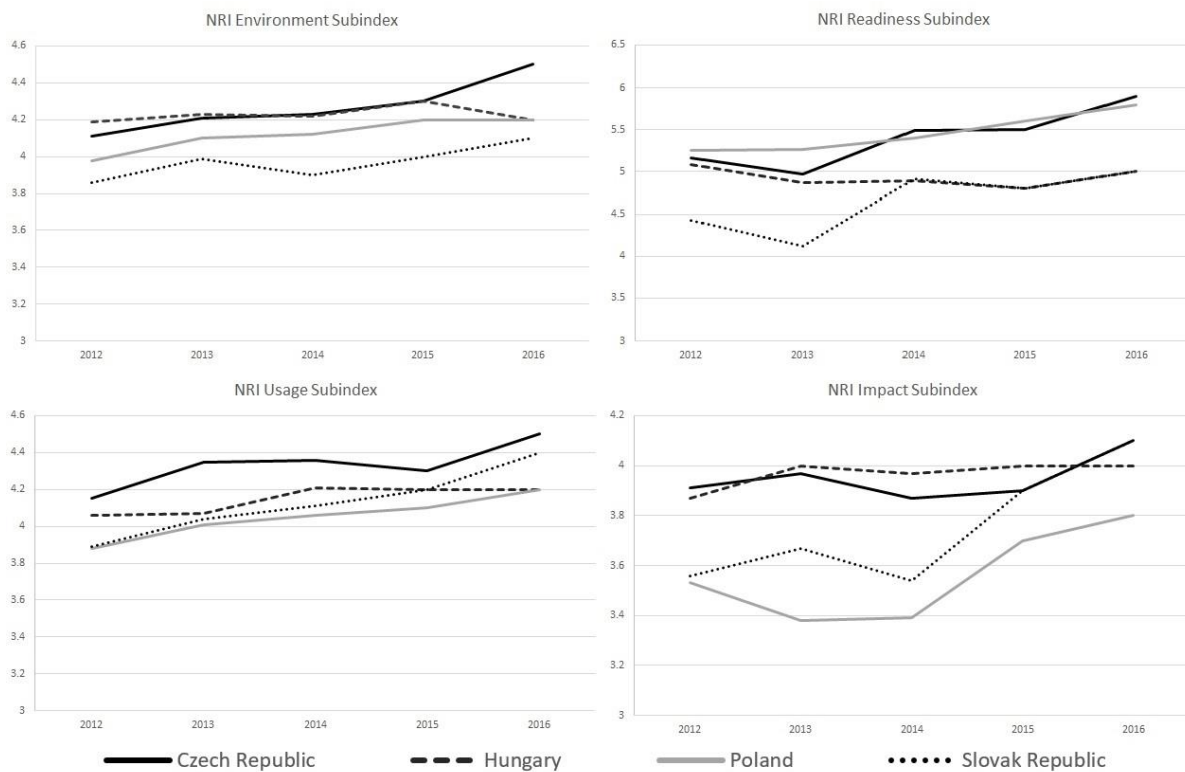

Figure/Chart 1: Changes in NRI subindexes for V4 countries in years 2012-2016 (Dutta, Bibloa-Osario, 2012, p. 13-16; Bibloa-Osario, Dutta, Lanvin, 2013, p. 12-15; Bibloa-Osario, Dutta, Lanvin, 2014, p. 11-14; Dutta, Geiger, Lanvin, 2015, p. 9-12; Baller, Dutta, Lanvin, 2016, p. 17-20)

### 3. COMPARISON USING GLOBAL COMPETITIVENESS INDEX RANKING

Another indicator chosen for analyzing ICT capacity is the Global Competitiveness Index (GCI), which has been presented in annual “Global Competitiveness Reports” since 2004 by the World Economic Forum. This indicator is used to measure the ability of individual states to ensure long-term economic growth. GCI is calculated on the basis of three subindexes (basic requirements subindex, efficiency enhancers subindex, innovation and sophistication factors subindex), that are weighted for each country in order to better account for its level of economic development. Thus, the individual subindexes are of the utmost importance for respectively factor-driven economies, efficiency driven economies and innovation-driven economies. The CGI ranks and scores of countries selected for comparison are presented in Table No 2. Values of this index (and its subindexes), as in the case of the NRI index, vary between 1.0 and 7.0 points. And just like in the case of the NRI, even the countries in the lead are not approaching the maximum potential value for this index. Unlike the case of NRI, in the period analysed, the value of GCI (and positions in the ranking) increased only for two of the V4 countries: the Czech Republic and Poland.



For the Slovak Republic and Hungary both position in ranking and the indicator score declined. Of course, it should be noted that the GCI is calculated using factors other than those related only to ICT potential. The three subindexes listed earlier (on which basis GCI is calculated) are based on a total number of 12 pillars and 114 variables. These pillars, respectively for each subindex, are as follows: 1) institutions, infrastructure, macroeconomic environment, health and primary education; 2) higher education and training, goods market efficiency, financial market development, technological readiness, market size; 3) business sophistication, innovation (Schwab, 2017, p. 12).

*Table 2: V4 countries in the GCI ranking in comparison to selected developed countries in years 2008-2017 (Porter, Schwab, 2008, p. 10; Schwab, 2009, p. 13; Schwab, 2010, p. 15; Schwab, 2011, p. 15; Schwab, 2012, p. 13; Schwab, 2013, p. 15; Schwab, 2014, p. 13; Schwab, 2015, p. 7; Schwab, 2016, p. 7; Schwab, 2017, p. 13)*

Country	GCI	2008-2009	2009-2010	2010-2011	2011-2012	2012-2013	2013-2014	2014-2015	2015-2016	2016-2017	2017-2018
Sweden	Rank	4	4	2	3	4	6	10	9	6	7
	Score	5.53	5.51	5.56	5.61	5.53	5.48	5.41	5.43	5.53	5.52
Finland	Rank	6	6	7	4	3	3	4	8	10	10
	Score	5.5	5.43	5.37	5.47	5.55	5.54	5.5	5.45	5.44	5.49
United States	Rank	1	2	4	5	7	5	3	3	3	2
	Score	5.74	5.59	5.43	5.43	5.43	5.47	5.54	5.61	5.7	5.85
Japan	Rank	9	8	6	9	10	9	6	6	8	9
	Score	5.38	5.37	5.37	5.4	5.49	5.4	5.47	5.47	5.48	5.49
Czech Republic	Rank	<b>33</b>	<b>31</b>	<b>36</b>	<b>38</b>	<b>39</b>	46	<b>37</b>	<b>31</b>	<b>31</b>	<b>31</b>
	Score	4.62	4.67	4.57	4.52	4.51	4.43	4.53	4.69	4.72	4.77
Hungary	Rank	62	58	52	48	60	63	60	63	69	60
	Score	4.22	4.22	4.33	4.36	4.3	4.25	4.28	4.25	4.2	4.33
Poland	Rank	53	46	39	41	41	<b>42</b>	43	41	36	39
	Score	4.28	4.33	4.51	4.46	4.46	4.46	4.48	4.49	4.56	4.59
Slovak Republic	Rank	46	47	60	69	71	78	75	67	65	59
	Score	4.4	4.31	4.25	4.19	4.14	4.1	4.15	4.22	4.28	4.33

In order to better identify the ICT potential, only the 2nd and 9th pillars were taken into account in further analysis – the 2nd Pillar Infrastructure being a part of Basic Requirements Subindex and the 9th Pillar Technological Readiness included in the Efficiency Enhancers Subindex. This choice was justified by the need to have the appropriate infrastructure for the sake of ICT implementation (2nd pillar) and potential level of preparedness for utilization of available technologies (9th pillar). Changes in values of both selected pillars for the V4 countries in the years 2008-2018 are presented in Graph No 2.

*Figure following on the next page*

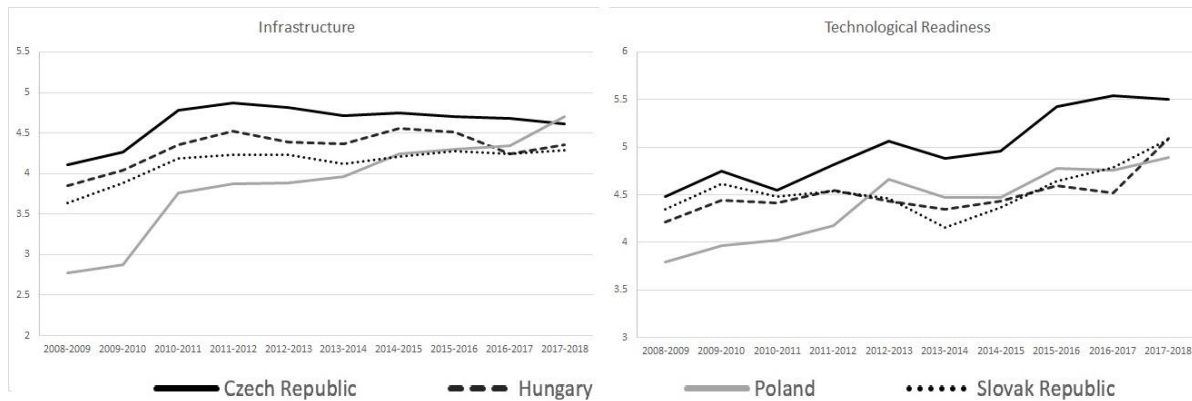

Figure/Chart 2: Changes in selected GCI subindexes for V4 countries in years 2008-2017 (Porter, Schwab, 2008, p. 14-17; Schwab, 2009, p. 16-19; Schwab, 2010, p. 18-21; Schwab, 2011, p. 18-21; Schwab, 2012, p. 16-19; Schwab, 2013, p. 18-21; Schwab, 2014, p. 16-19; Schwab, 2015, p. 10-13; Schwab, 2016, p. 46-49; Schwab, 2016, p. 328-331)

On the basis of the selected pillars, clear differences between V4 countries can be observed. The best results in the case of both pillars are achieved by the Czech Republic. The difference is more visible in the case of the 9th Pillar Technological Readiness, whose value for the Czech Republic is significantly higher (0.41 point) than for the Hungary which is second in terms of this indicator in 2017. The greatest increase in the value of the 2nd pillar during the period considered can be observed in the case of Poland, but taking into account the fact that this indicator is measured including all types of infrastructure and not only the telecommunication one, it can be assumed that this increase is due to investments in other types of infrastructural projects (e.g. transportation infrastructure). It is worth noting that for all V4 countries the value of the indicators for 2017 is close to (2nd pillar), higher (9th pillar) or significantly higher (9th pillar for the Czech Republic - 0.73) than the general GCI index.

#### 4. COMPARISON USING DIGITAL ECONOMY AND SOCIETY INDEX

The last indicator selected for the comparison is the Digital Economy and Society Index (DESI). This index presents the progress of European Union Member States in achieving digital competitiveness. The index is being developed as part of the Digital Scoreboard and the European Digital Progress Report evaluating EU progress towards the European digital society and the realization of the Digital Agenda for Europe goals. Due to the fact that this indicator is calculated only for the EU Member States, the V4 countries were compared only to the two developed economies of the EU, i.e. Sweden and Finland and the average value of the indicator calculated for the EU as a whole organization. Comparison of DESI values for selected economies in the years 2014-2018 is presented in Table No 3. It should be noted that the value of DESI given for 2018 is only a forecast and may change as a result of the recalculation at the beginning of next year (2019).

Table following on the next page

Table 3: V4 countries in the DESI ranking in comparison to selected developed countries in years 2014-2018 (Digital Economy and Skills, 2018)

Country	2014		2015		2016		2017		2018	
	Rank	Score	Rank	Score	Rank	Score	Rank	Score	Rank	Score
Sweden	2	0.63	1	0.68	3	0.65	3	0.67	2	0.70
Finland	4	0.59	3	0.66	2	0.66	2	0.67	3	0.70
Czech Republic	17	0.42	15	0.5	17	0.46	17	0.49	17	0.52
Hungary	22	0.37	21	0.45	20	0.43	22	0.44	23	0.46
Poland	24	0.36	22	0.42	24	0.4	24	0.42	24	0.45
Slovak Republic	19	0.4	20	0.45	22	0.41	20	0.45	20	0.49
EU Avarage		0.44		0.5		0.49		0.50		0.54

The data presented made the difference between the highly-developed EU Member States selected for comparison and the V4 countries clearly visible. In most cases, the value of the DESI indicator for V4 countries is lower than the EU average - the Czech Republic being the only exception in 2015 with the value of the index at the level of the EU average. In the case of this indicator, it is also possible to distinguish components for measuring various aspects of the development and utilization of ICT potential. They are as follows (Digital Economy and Skills, 2018):

1. Connectivity – i.e. the quantitative and qualitative aspects of broadband infrastructure,
2. Human Capital/Digital skills – describing various skills required to achieve the benefits offered by the information society,
3. Use of Internet by citizens – exploring what kind of activities are undertaken by the users in Internet,
4. Integration of Digital Technology by businesses – the level of digitalization in business and the use of online sales channels
5. Digital Public Services – the level of digitalization of public services, with particular emphasis on eGovernment.

Values of individual subindexes for V4 countries in 2017 are presented in Table No 4. The decision to present data for 2017 is based on the fact that values for 2018 are a forecast and may be changed after recalculation based on actual data for 2018 (such recalculation should take place during preparation of the new report for 2019).

Table 4: The values of DESI subindexes for V4 countries in year 2017 (Digital Economy and Skills, 2018)

Country	Czech Republic		Hungary		Poland		Slovak Republik		EU Avarage
	Rank	Score	Rank	Score	Rank	Score	Rank	Score	Score
1. Connectivity	16	<b>0.59</b>	18	0.57	22	0.52	24	0.50	0.58
2. Human Capital	13	0.53	18	0.49	21	0.45	15	0.50	0.54
3. Use of Internet	21	0.43	12	<b>0.51</b>	24	0.40	15	<b>0.49</b>	0.47
4. Integration of Digital Technology	11	<b>0.40</b>	24	0.23	27	0.21	21	0.30	0.36
5. Digital Public Services	23	0.44	28	0.33	18	0.48	24	0.44	0.53
DESI	17	0.49	22	0.44	24	0.42	20	0.40	0.50

In the table presented, scores of indicators for which the value reached by the V4 country was at or above the EU average were highlighted. The fact that the value of the overall DESI index in 2017 for none of the V4 countries did not reach the EU average value, once more indicates the difference in approach to assuring the utilization of ICT by V4 countries. On the other hand, the high values of some of the individual subindexes indicate already high levels of development

(on or above the EU average) in selected areas concerning utilization of ICT potential. In 2017, only the Poland didn't exceed the average value for the EU in any of the subindexes described.

## 5. CONCLUSION

In conclusion, the analysis of selected indicators describing the possibilities of using ICT potential for growth and competitiveness allows for making several conclusions. The changes in V4 positions in the respective rankings for the years 2012-2018 are presented in Table No 5. Choice of this time frame for comparison results from changes in the NRI calculation methodology that took place in 2012.

*Table 5: Comparison of GCI, NRI and DESI indicators for V4 countries in years 2012-2017 (Digital Economy and Skills, 2018; Schwab, 2012, p. 13; Schwab, 2013, p. 15; Schwab, 2014, p. 13; Schwab, 2015, p. 7; Schwab, 2016, p. 7; Schwab, 2017, p. 13; Dutta, Bibloa-Osario, 2012, p. 12; Bibloa-Osario, Dutta, Lanvin, 2013, p. 11; Bibloa-Osario, Dutta, Lanvin, 2014, p. 10; Dutta, Geiger, Lanvin, 2015, p. 8; Baller, Dutta, Lanvin, 2016, p. 16)*

Country	Index	2012	2013	2014	2015	2016	2017
Czech Republic	GCI	<b>39</b>	46	<b>37</b>	<b>31</b>	<b>31</b>	<b>31</b>
	NRI	<b>42</b>	<b>42</b>	<b>42</b>	<b>43</b>	<b>36</b>	-
	DESI	-	-	<b>17</b>	<b>15</b>	<b>18</b>	<b>17</b>
Hungary	GCI	60	63	60	63	69	60
	NRI	43	44	47	53	50	-
	DESI	-	-	22	21	20	22
Poland	GCI	41	42	43	41	36	39
	NRI	49	49	54	50	42	-
	DESI	-	-	24	22	24	34
Slovak Republic	GCI	71	78	75	67	65	59
	NRI	64	61	59	59	47	-
	DESI	-	-	19	20	22	20

Despite the different calculation methodologies used in the preparation of all the selected indicators (NRI, GCI, DESI), it can be observed that the rankings' positions (resulting from country-specific indicators' values) show some dependence - the order of countries in the respective rankings is usually unchanged. The Czech Republic as always the first of the V4 countries in the rankings analysed (in the period 2012-2016, with only one exception - GCI in year 2013), has the highest overall ICT potential of all the V4 countries. For other V4 countries, the situation is not so obvious: Poland usually appears second in terms of GCI and NRI rankings' position, but only in third place while considering the DESI index (behind the Slovak Republic). The situation with GCI and NRI indicators is reversed in the case of Hungary and the Slovak Republic - they have deteriorated in the period analyzed for Hungary and improved for the Slovak Republic. However, it should be noted that big differences observed in the rankings' positions do not translate into significant differences in the general values of indicators analyzed. The evaluation of the potential of ICT use in V4 countries requires further research, taking into account a longer time span, which unfortunately is not possible using the indicators selected and used by the author.

## LITERATURE:

1. Baller, S., Dutta, S., Lanvin, B., ed. (2016). *The Global Information Technology Report 2016: Innovating in the Digital Economy*. Geneva: World Economic Forum. Retrieved 22.10.2018 from [http://reports.weforum.org/global-information-technology-report-2016/?doing\\_wp\\_cron=1541260290.7254230976104736328125](http://reports.weforum.org/global-information-technology-report-2016/?doing_wp_cron=1541260290.7254230976104736328125).

2. Bibloa-Osario, B., Dutta, S., Lanvin, B., ed. (2013). *The Global Information Technology Report 2013: Growth and Jobs in a Hyperconnected World*. Geneva: World Economic Forum. Retrieved 22.10.2018 from <http://reports.weforum.org/global-information-technology-report-2013/#=>.
3. Bibloa-Osario, B., Dutta, S., Lanvin, B., ed. (2014). *The Global Information Technology Report 2014: Rewards and Risks of Big Data*. Geneva: World Economic Forum. Retrieved 22.10.2018 from <http://reports.weforum.org/global-information-technology-report-2014/#=>.
4. Cruz-Jesus, F., Oliveira, T., & Bacao, F. (2012). Digital divide across the European Union. *Information & Management*, No. 49 (6), pp. 278-291. ISSN: 0378-7206. Retrieved 25.10.2018 from doi:10.1016/j.im.2012.09.003.
5. Digital agenda for Europe. (2010). *Digital agenda for Europe 2010-2020: Communication from the Commission to the European Parliament, the Council, the European Economic and Social Committee and the Committee of the Regions*. COM/2010/0245 f/2. Retrieved 20.10.2018.  
[https://eur-lex.europa.eu/legal-content/EN/ALL/?uri=CELEX:52010DC0245R\(01\)](https://eur-lex.europa.eu/legal-content/EN/ALL/?uri=CELEX:52010DC0245R(01)).
6. Digital Economy and Skills (Unit F.4). (2018). *The Digital Economy and Society Index (DESI)*. Brussels: European Commission. Retrieved 11.11.2018.  
<https://ec.europa.eu/digital-single-market/en/desi>.
7. Dutta, S., Bibloa-Osario, B., ed. (2012). *The Global Information Technology Report 2012: Living in a Hyperconnected World*. Geneva: World Economic Forum. Retrieved 21.10.2018 from <http://reports.weforum.org/global-information-technology-2012/#=>.
8. Dutta, S., Geiger, T., Lanvin, B., ed. (2015). *The Global Information Technology Report 2015: ICTs for Inclusive Growth*. Geneva: World Economic Forum. World Economic Forum. Retrieved 22.10.2018 from <http://reports.weforum.org/global-information-technology-report-2015/>.
9. Dutta, S., Mia, I. (2009). *The Global Information Technology Report 2008-2009: Mobility in a Networked World*. Geneva: World Economic Forum. Retrieved 21.10.2018 from <https://www.ifap.ru/library/book420.pdf>.
10. Dutta, S., Mia, I. (2011). *The Global Information Technology Report 2010-2011: Transformations 2.0*. Geneva: World Economic Forum. Retrieved 21.10.2018 from <http://reports.weforum.org/global-information-technology-2011/#=>.
11. Emrouznejad, A., Cabanda, E., Gholami, R. (2010). An alternative measure of the ICT-Opportunity Index. *Information & Management*, 47, p. 246–254. ISSN: 0378-7206. Retrieved 23.10.2018 from doi:10.1016/j.im.2010.04.002.
12. Katz, R., Koutroumpis, P., Callorda F. M. (2014). Using a digitization index to measure the economic and social impact of digital agendas. *Info*, Vol. 16 No. 1, p. 32-44. ISSN: 1463-6697. Retrieved 24.10.2018 from doi:10.1108/info-10-2013-0051.
13. Misuraca, G., Codagnone, C., Rossel, P. (2013). From Practice to Theory and back to Practice: Reflexivity in Measurement and Evaluation for Evidence-based Policy Making in the Information Society. *Government Information Quarterly*, 30, p. S68–S82. ISSN: 0740-624X. Retrieved 23.10.2018 from <http://dx.doi.org/10.1016/j.giq.2012.07.011>.
14. Porter, M., Schwab, K. (2008). *The Global Competitiveness Report 2008-2009*. Geneva: World Economic Forum. Retrieved 24.10.2018 from <https://www.weforum.org/reports/global-competitiveness-report-2008-2009>.
15. Schlichter, B. R., Danylchenko, L. (2014). Measuring ICT usage quality for information society building. *Government Information Quarterly*, 31, ps. 170–184. ISSN: 0740-624X. Retrieved 23.10.2018 from <http://dx.doi.org/10.1016/j.giq.2013.09.003>.

16. Schwab, K. (2009). *The Global Competitiveness Report 2009-2010*. Geneva: World Economic Forum. Retrieved 24.10.2018 from <https://www.weforum.org/reports/global-competitiveness-report-2009-2010>.
17. Schwab, K. (2010). *The Global Competitiveness Report 2010-2011*. Geneva: World Economic Forum. Retrieved 24.10.2018 from <https://www.weforum.org/reports/global-competitiveness-report-2010-2011>.
18. Schwab, K. (2011). *The Global Competitiveness Report 2011-2012*. Geneva: World Economic Forum. Retrieved 24.10.2018 from <https://www.weforum.org/reports/global-competitiveness-report-2011-2012>.
19. Schwab, K. (2012). *The Global Competitiveness Report 2012-2013*. Geneva: World Economic Forum. Retrieved 26.10.2018 from <http://reports.weforum.org/global-competitiveness-report-2012-2013/#=>.
20. Schwab, K. (2013). *The Global Competitiveness Report 2013-2014*. Geneva: World Economic Forum. Retrieved 26.10.2018 from <https://www.weforum.org/reports/global-competitiveness-report-2013-2014>.
21. Schwab, K. (2014). *The Global Competitiveness Report 2014-2015*. Geneva: World Economic Forum. Retrieved 26.10.2018 from [http://reports.weforum.org/global-competitiveness-report-2014-2015/?doing\\_wp\\_cron=1541323496.9789099693298339843750](http://reports.weforum.org/global-competitiveness-report-2014-2015/?doing_wp_cron=1541323496.9789099693298339843750).
22. Schwab, K. (2015). *The Global Competitiveness Report 2015-2016*. Geneva: World Economic Forum. Retrieved 26.10.2018 from <http://reports.weforum.org/global-competitiveness-report-2015-2016/>.
23. Schwab, K. (2016). *The Global Competitiveness Report 2016-2017*. Geneva: World Economic Forum. Retrieved 26.10.2018 from <https://www.weforum.org/reports/the-global-competitiveness-report-2016-2017-1>.
24. Schwab, K. (2017). *The Global Competitiveness Report 2017-2018*. Geneva: World Economic Forum. Retrieved 26.10.2018 from <https://www.weforum.org/reports/the-global-competitiveness-report-2017-2018>.
25. Vu, K. M. (2011). ICT as a source of economic growth in the information age: Empirical evidence from the 1996–2005 period. *Telecommunications Policy*. No. 35 (4), p. 357-372. ISSN: 0308-5961. Retrieved 23.10.2018 from doi:10.1016/j.telpol.2011.02.008.

# SPACE-TIME CLASSIFICATION OF THE COUNTRIES OF THE EUROPEAN CONTINENT IN THE CONTEXT OF THE DEVELOPMENT OF GLOBALIZATION

**Monika Hadas-Dyduch**

*University of Economics in Katowice,*

*Faculty of Economics,*

*Department of Statistical and Mathematical Methods in Economics,*

*40-287 Katowice, ul. 1 Maja 50, Poland*

*monika.dyduch@ue.katowice.pl*

## **ABSTRACT**

*The aim of the article is to identify a group of countries characterized by a similar development of globalization over various time spans, i.e. both in the long term and short term. The analysis described in this article is based on the globalization index, which combines the following in one figure: actual economic flows, economic restrictions, data on information flows, data on personal contact and data on cultural proximity. The research analysis was based on wavelet analysis, discrete wavelet analysis and non-linear ordering. Non-linear ordering consists, in geometric terms, in projecting objects placed in a multidimensional space of variables onto a plane. It does not allow the objects to be placed in a hierarchy, but only permits definition of objects similar to each of the objects. A discrete wavelet was used for wavelet analysis of the time series studied. In the process of discrete wavelet transformation, the received signal is divided into so-called approximation and detail. Approximation is then subjected to a subsequent division into further approximation and detail, while details are not subject to further divisions. In this way, the signal is presented as the sum of the approximation of the last level and the details from all levels. In the article, globalization is understood as a process of interaction and integration among the people, companies, and governments of different nations, a process driven by international trade and investment and aided by information technology. This process has effects on the environment, on culture, on political systems, on economic development and prosperity, and on human physical well-being in societies around the world.*

**Keywords:** *classification, globalization, internationalization, ordering, wavelets*

## **1. INTRODUCTION**

Globalization is a multifaceted phenomenon that affects every sphere of modern life. It can be said that globalization is the growing penetration into markets and the increase in the internationalization of production, distribution, marketing and exchange. It is accompanied by the process of reducing the costs of obtaining and transmitting information, thus increasing the availability of access to modern technology for an increasing number of countries and societies. Like every process, it has its supporters and opponents (see: Ashenfelter, Engle, McFadden, & Schmidt-Hebbel, 2018), as there are both advantages and disadvantages, and its effects on society are both positive and negative (see: Hadaś-Dyduch, 2016). The positive effects of globalization include (see: Nistor, 2007; Olteanu & Radoi, 2010):

- scientific and technical progress (e.g. internet, mobile phones),
- international trade,
- technological development (e.g. minimization of computer hardware),
- easy communications,
- economic integration (e.g.: EU, UN, OECD),
- greater variety of product types,
- easy access to information,

- development of transport,
- removing barriers to international trade,
- opportunities to participate in transnational projects,
- improvements in new, modern products,
- familiarisation with other cultures and customs.

However, some positive aspects may, from a different point of view, be seen as negative aspects. For example, inter-cultural exchange that can lead to the blurring of cultural identity in the long run, where every citizen aspires to the same cultural patterns of behaviour. Globalization concerns every citizen and, as statistics show, it is inevitable. In the article, the study was based on the globalization index, which is a "multi-continental distaste", mediated through a variety of people, and provides information, ideas and ideas (Dreher & Gaston , 2007). "Thus, we define that" globalization is a process that integrates national economies, cultures, and governance, and produces a complex relationship of mutual interdependence (Dreher & Gaston, 2007). "

## 2. THE DEVELOPMENT OF GLOBALIZATION

Analysis of the development of globalization in the world on the basis of the KOFGI<sup>1</sup> globalization indicator, shows that an upward trend is clearly visible (see Figure 1). Since 1970, the world globalization index has grown every year by an average of 0.97% and is characterized by 15% volatility.

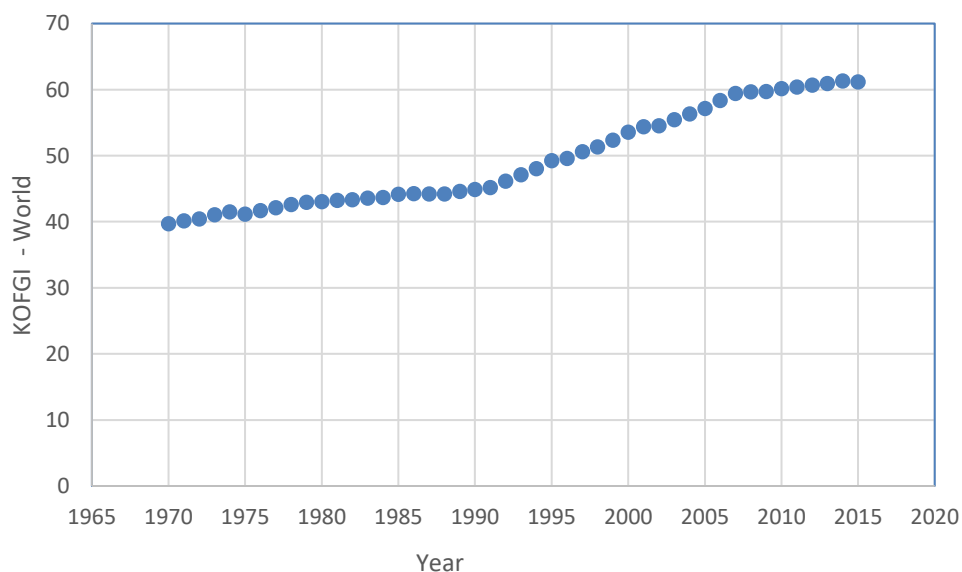

Figure 1: The formation of KOFGI in the world (Own elaboration).

<sup>1</sup> "Data are calculated on a yearly basis. However, not all data are available for all countries and all years.

In calculating the indices, all variables are linearly interpolated before applying the weighting procedure. Instead of linear extrapolation, missing values at the border of the sample are substituted by the latest data available. When data are missing over the entire sample period, the weights are readjusted to correct for this. When observations with value zero do not represent missing data, they enter the index with weight zero. Data for sub-indices and the overall index of globalization are not calculated, if they rely on a small range of variables in a specific year and country. Observations for the index are reported as missing if more than 40 percent of the underlying data are missing or at least two out of the three sub-indices cannot be calculated. The indices on economic, social and political globalization as well as the overall index are calculated employing the weighted individual data series instead of using the aggregated lower-level globalization indices. This has the advantage that data enter the higher levels of the index even if the value of a sub-index is not reported due to missing data (Dreher, Gaston, & Martens, 2008)".



At the same time, in the East Asia & Pacific index of globalization increases on average by 1.04% annually (variation of 15.4%), in Europe & Central Asia by 0.68% (10% variation), in Latin America & Caribbean by 0.9% (14.4% diversification), in Middle East & North Africa by 0.95% (13.2% difference), in North America by 0.58% (8.7% differentiation), in South Asia by 1.36% (22.9% difference), in Sub-Saharan Africa by 1.18% (diversification 17.3%). North America has the largest globalization rate (see the comparison in Figure 2).

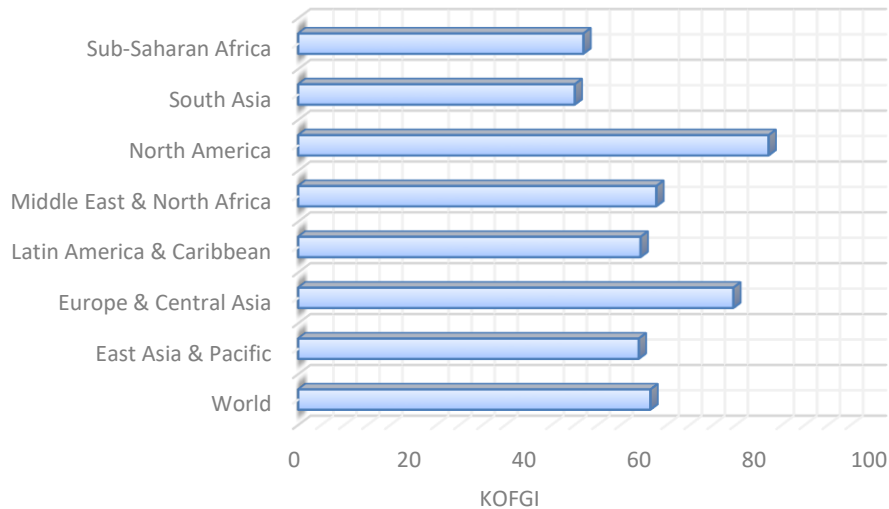
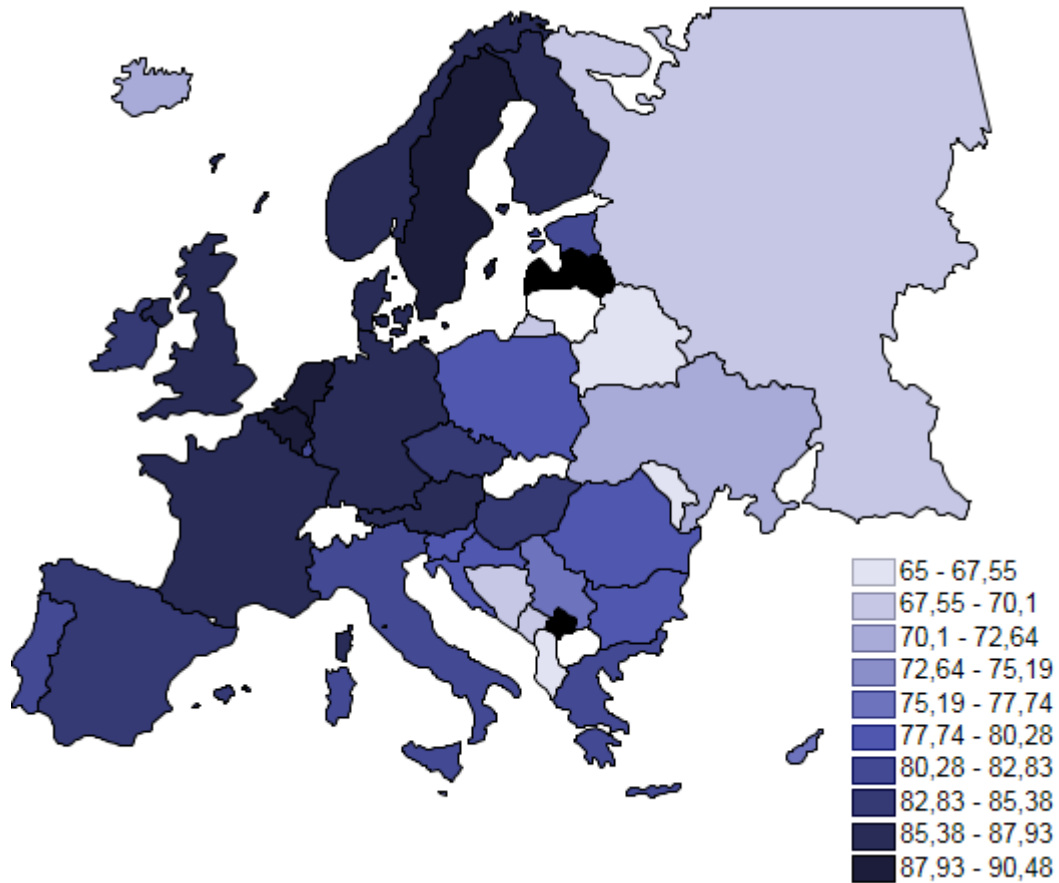

Figure 2: KOFGI (Own elaboration).

The 10 countries with the largest globalization rate in Europe include (Figure 2): Norway (85,81), Finland (85,98), Germany (86,89), the United Kingdom (87,23), France (87,34), Denmark (87.85), Austria (87.91), Sweden (88.05), the Netherlands (90.24), Belgium (90.47). However, the top ten countries with the lowest globalization rate include (Figure 3): Kazakhstan (59,10), Azerbaijan (59,29), Belarus (65,00), Moldova (67,00), Albania (67,19), Montenegro (69.03), Russia (69.06), Bosnia and Herzegovina (69.48), Ukraine (70.60), Iceland (70.62).

Figure following on the next page



*Figure 3: The current value of the globalization index in individual countries of the European continent. (Own elaboration).*

The rate of globalization development in individual countries of the European continent varies and ranges from 4.95% to 34.27%. The least diversified pace of globalization development (starting from 1970) is in Luxembourg, and the most diverse is in Azerbaijan (see map shown in Figure 4).

*Figure following on the next page*

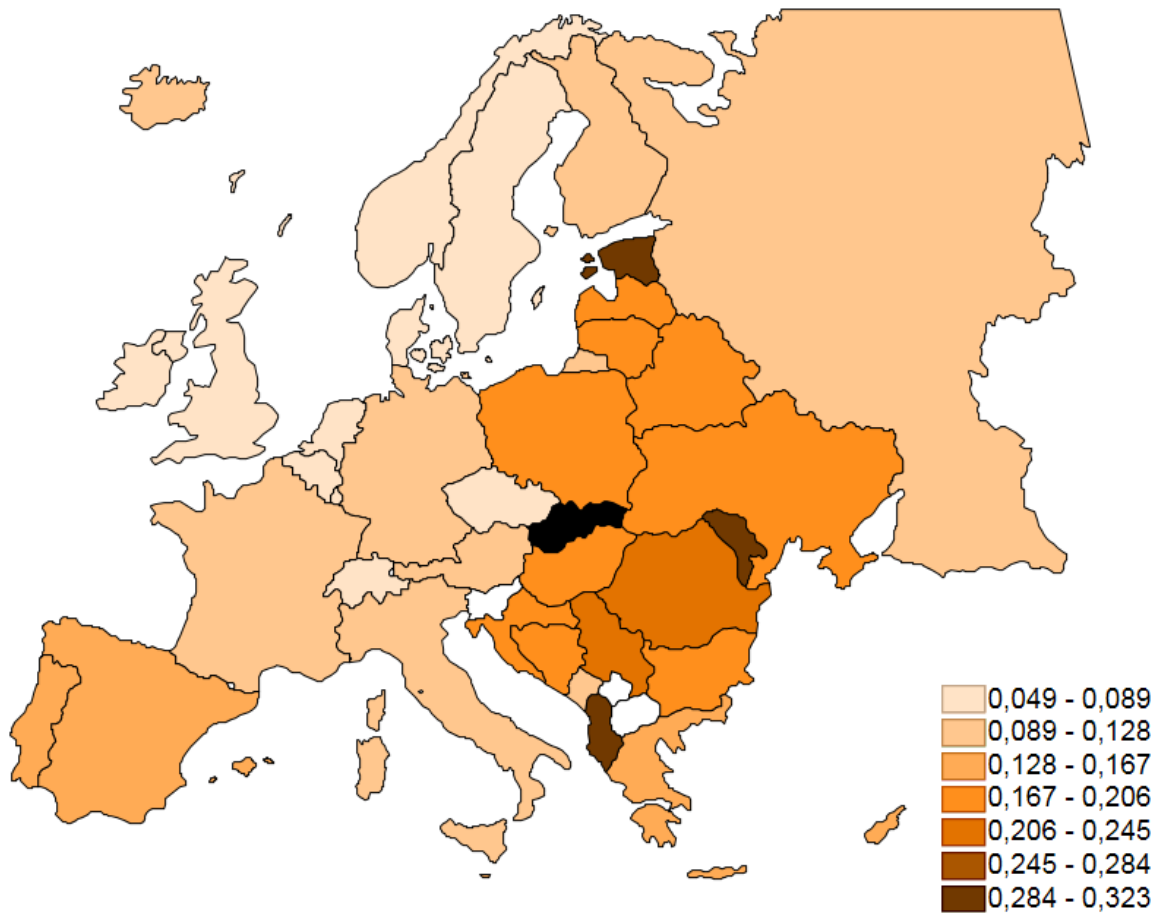

*Figure 4: Diversification of the globalization index (data from 1970) in individual countries of the European continent [in%]. (Own elaboration).*

Analyzing particular countries belonging to the European continent, the highest growth rate of the globalization index (since 1993) is in countries such as Belarus (average annual growth of 4.34%), Georgia (average annual growth of 4.44%), Azerbaijan (average annual growth by 4.52%), Kazakhstan (average annual growth of 4.76%), Moldova (average annual growth of 4.85%). The smallest growth rate of the indicator can be observed in Luxembourg (see map shown in Figure 5).

*Figure following on the next page*

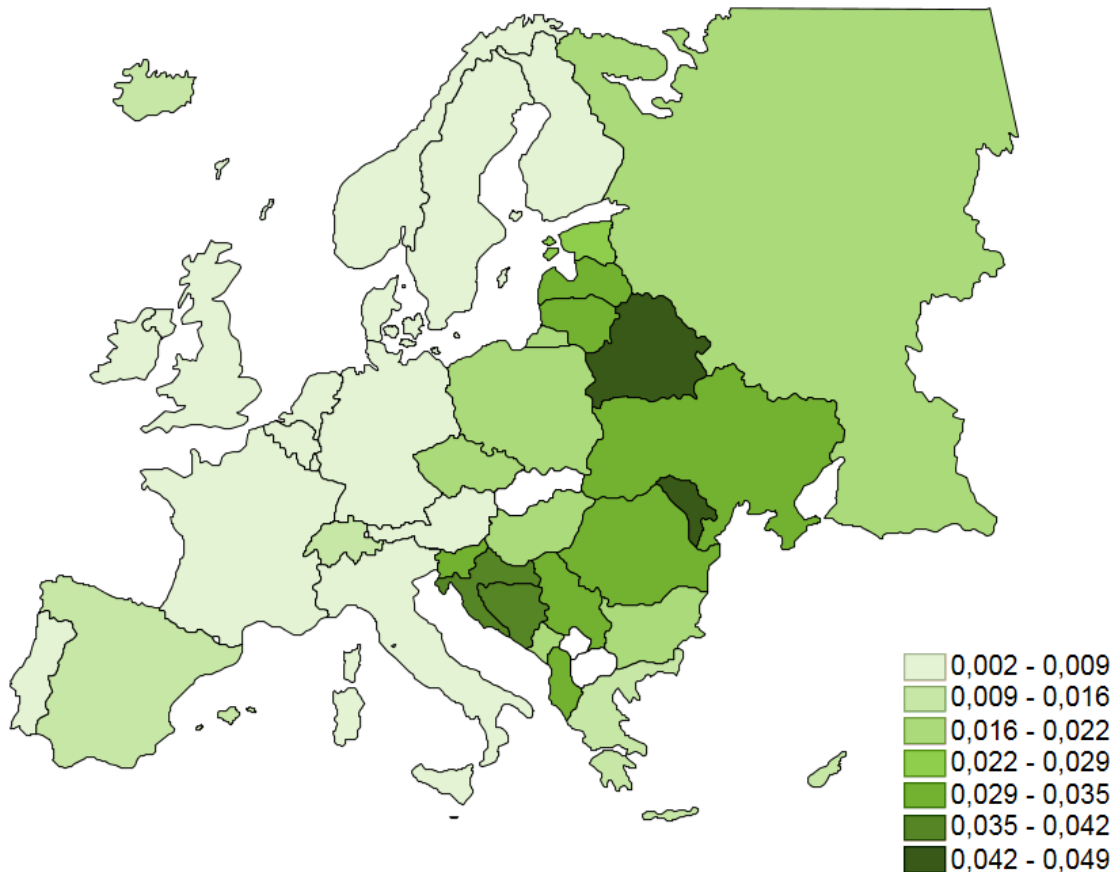

Figure 5: The rate of increase in the globalization index (since 1993) in individual countries of the European continent. (Own elaboration).

### 3. EMPIRICAL ANALYSIS

The aim of the article is to indicate a group of countries characterized by the underdevelopment of globalization over various time spans, i.e. both in the long term and short term. The study was based on the globalization index set out for the countries belonging to the European continent, characterized briefly above in Chapter 1 and Chapter 2. The globalization index included in the study, “describes the process of creating networks of connections among actors at intra- or multi-continental distances, mediated through a variety of flows including people, information and ideas, capital, and goods (Dreher & Gaston, 2007).” (Due to a lack of complete data in the study, the following countries from the European continent were not included: Andorra, Kosovo, Latvia, Macedonia, Slovakia, Switzerland, the Vatican. The study was therefore based on 36 countries belonging to Europe. The data used is from 1970 onwards.

#### 3.1. Research tool

The research analysis was based on wavelet analysis, discrete wavelet and nonlinear ordering. Non-linear ordering consists, from the geometric side, in projecting objects placed in a multidimensional space of variables into a plane. It does not allow to set the hierarchy of objects, but only to define for each of the objects, similar objects.

Wavelets we call function  $\Psi(x) \in L^2(\mathbb{R})$ , such that the system function:

$$B_\Psi = \left\{ 2^{\frac{j}{2}} \Psi(2^j x - k) \right\}; \quad j \in \mathbb{Z}, \quad k \in \mathbb{Z} \quad (1)$$

is an orthonormal basis in the space  $L^2(\mathbb{R})$ . Family  $B_\Psi$  is called wavelet base.

The simplest wavelet is the Haar wavelet. The Haar wavelets we call a function on the real line  $\mathbb{R}$  defined by the formula:

$$H(x) = \begin{cases} 1 & \text{for } x \in \left[0, \frac{1}{2}\right) \\ -1 & \text{for } x \in \left[\frac{1}{2}, 1\right) \\ 0 & \text{for other } x \end{cases}$$

It should be mentioned that the wavelets are defined as wavelet functions and scaling functions. The wavelet functions are commonly called the mother wavelets, and the scaling wavelet are called the father wavelet. As Addison (2002) stresses: “ (...) the wavelet function is in effect a band-pass filter and scaling it for each level halves its bandwidth. This creates the problem that in order to cover the entire spectrum, an infinite number of levels would be required. The scaling function filters the lowest level of the transform and ensures all the spectrum is covered (...). For a wavelet with compact support,  $\varphi$  can be considered finite in length and is equivalent to the scaling filter  $g$ ”.

### 3.2. A brief description of the algorithm

Wavelet analysis and non-linear ordering were used for the study. The algorithm constructed for this study was subjectively named WWK. The key steps of the WWK algorithm used in the study are summarized below.

- Step 1 Enter data (time series) to the model. The series contains  $2^n$  observations.
- Step 2 Extension of individual series
- Step 3 Calculation of wavelet factors (see Hadaś-Dyduch, 2015).
- Step 4 Discrete wavelet transform
- Step 5 Wavelet coefficients: detail ( $d^{(n-1)}$ ) and approximation ( $a^{(n-1)}$ ) at the first level of resolution
- Step 6 Initial division of the set and objects represented by wavelet factors into  $k$  classes.
- Step 7 Determination of centers of gravity of individual classes.
- Step 8 Determination of the value of the function used as a criterion for the quality of the classification.
- Step 9 Designation for one of the objects to change the value of the function of the classification quality criterion resulting from the object being moved to each of the currently occurring classes.
- Step 10 Classification
- Step 11 Discrete wavelet transform
- Step 12 Wavelet coefficients: detail and approximation at the second level of resolution
- Step 13 Division of the set of  $m$  objects represented by wavelet factors into  $l$  classes.
- Step 14 A discrete wavelet transform
- Step 15 Wavelet coefficients: detail and approximation at the third level of resolution
- Step 16 Breakdown of the set  $p$  of objects represented by wavelet factors into  $j$  classes.

### 3.3. Results

Based on the above-described algorithm, the required calculations and simulations were made using the Matlab program (authored script). The results obtained allow us to formulate several basic conclusions.

The development of the globalization index for European continent countries in the short term can be divided into 12 groups. However, by making a further, more general classification, it is possible to divide these into five groups or three groups as shown in the figure. The membership of countries in individual groups was estimated based on the presented original algorithm, taking into account the classification in the last phase. As shown in the figure, the group most different to the others in terms of their means of striving for globalization is a group composed of only two countries, i.e. the Czech Republic and Bosnia and Herzegovina.

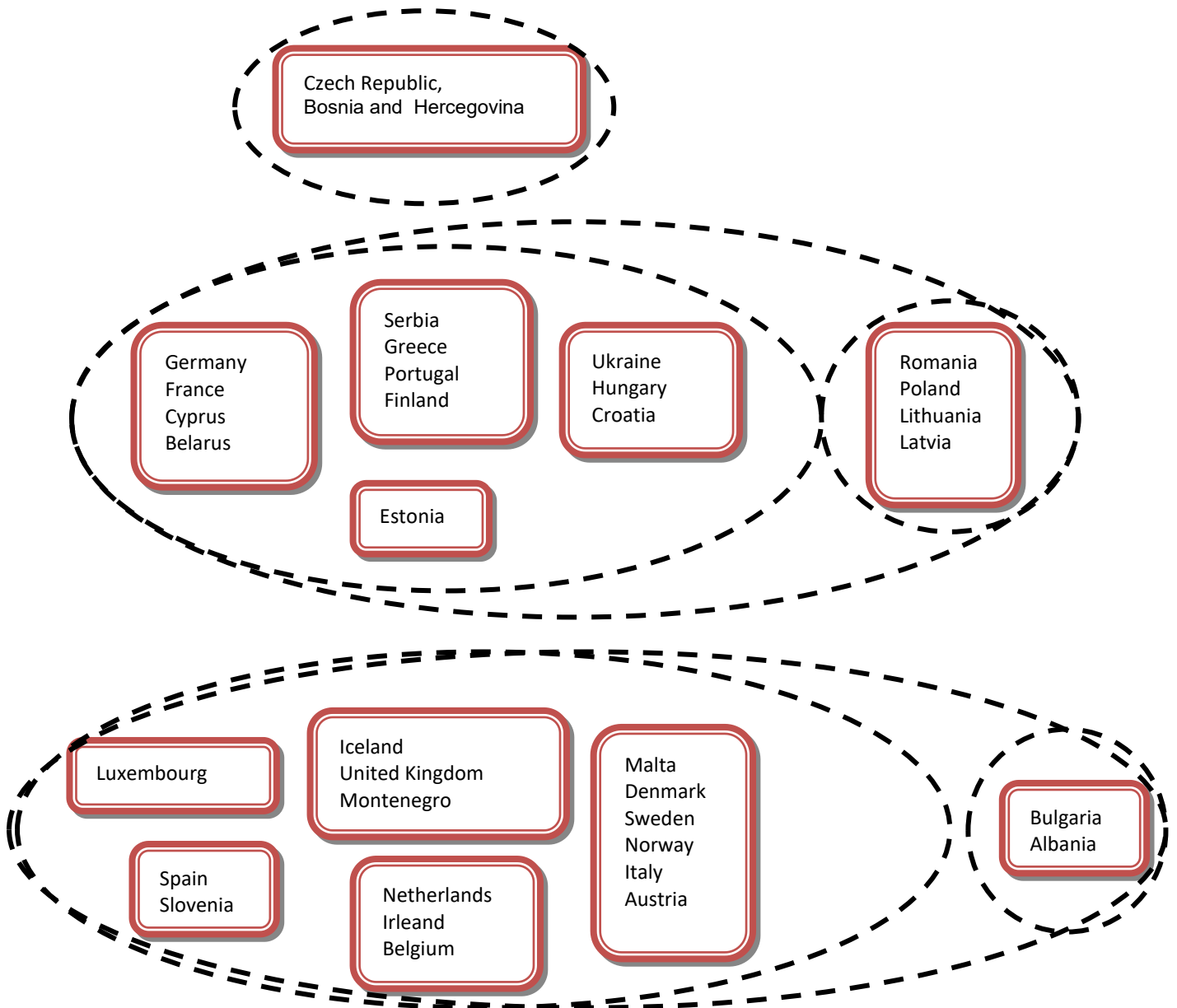

Figure 4: Classification result - 2-year trend. (Own elaboration).

The development of globalization of the countries of the European continent in terms of oscillations around the trend of 24-48 months is so shaped that three main trends can be identified. The countries belonging to each individual group are presented in the following figure (isolation based on the WWK algorithm).

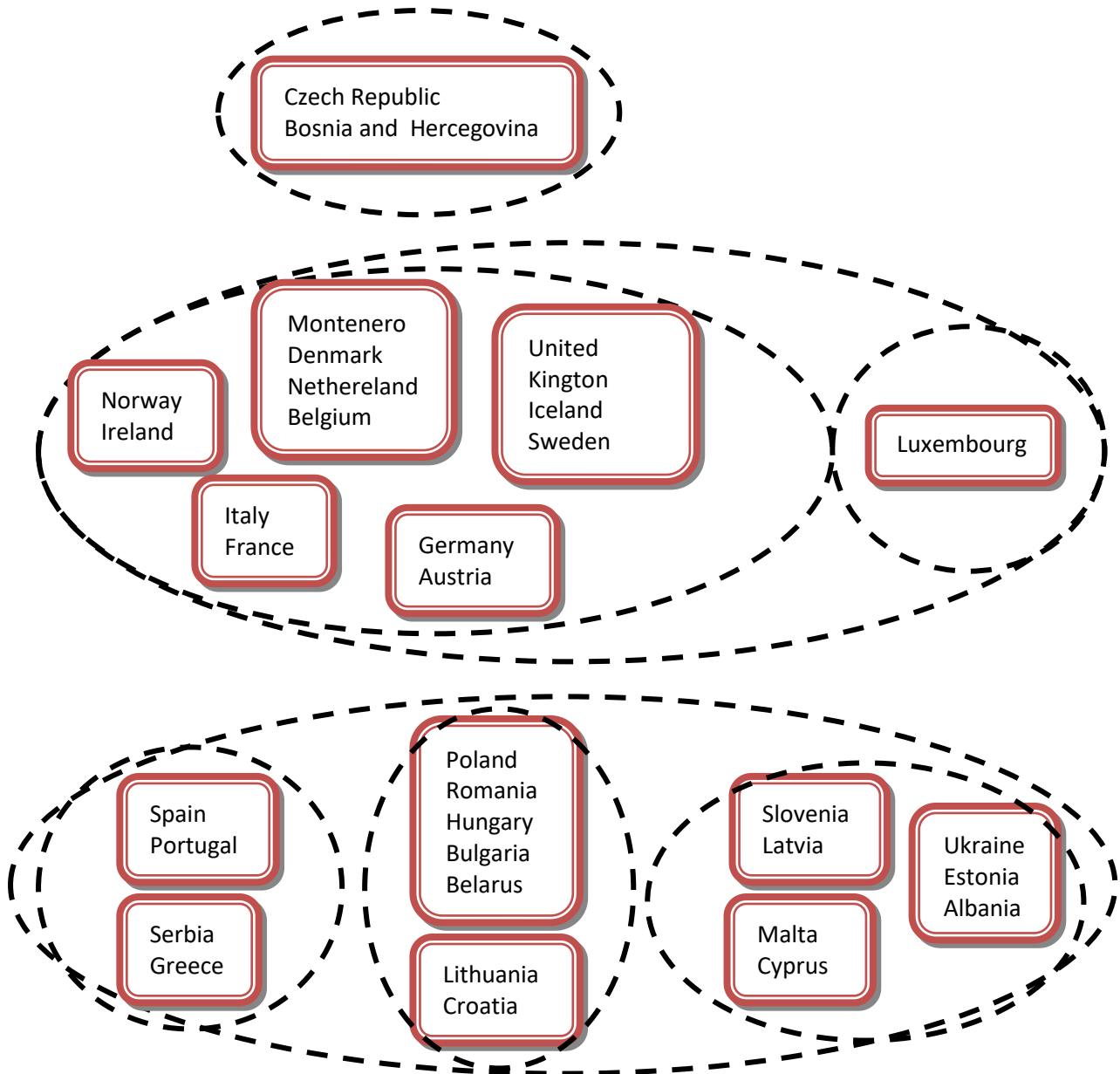

Figure 5: Classification result - 2-4 years. (Own elaboration).

The development of globalization of the countries of the European continent in the long term can be represented using three basic groups. The membership of countries in particular groups was estimated on the basis of the presented original algorithm, including in the last phase of the classification. The countries belonging to each individual group are presented in the figure below.

Figure following on the next page

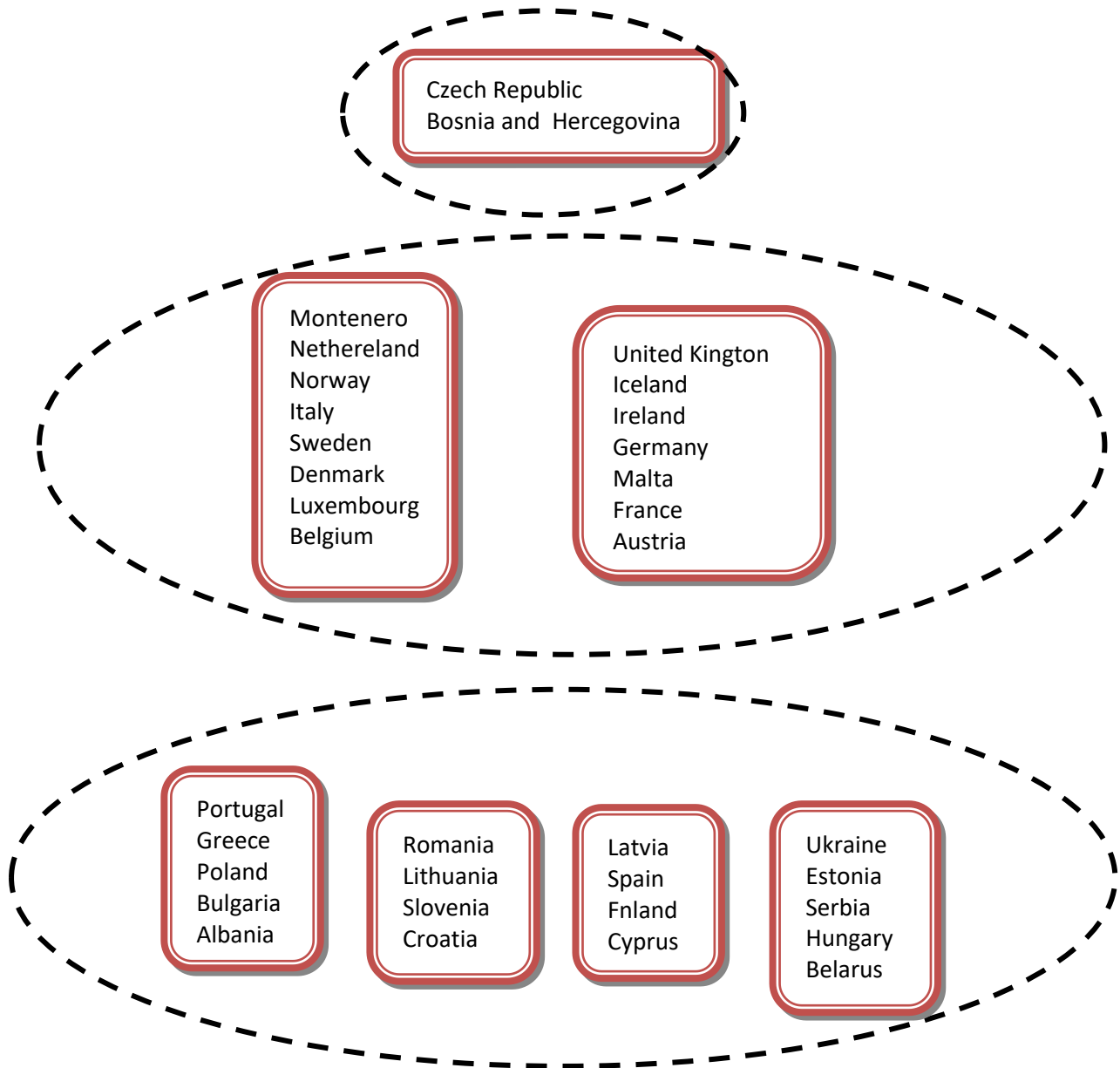

Figure 6: Classification result - trend of 4-8 years. (Own elaboration).

#### 4. CONSLUSION

Globalization has its opponents and supporters, partly because it is an irreversible process. It is a process in which markets and production in different countries are becoming more interdependent in connection with the dynamics of the exchange of goods and services, the flow of capital, and technology. Globalization means reducing barriers between countries and strengthening economic, political and social ties, leading to the creation of a global market for goods, services and capital, and the formation of a new international division of labor. Globalization can be modeled using various methods (see Hadaś-Dyduch 2015a, 2015b, 2015c, 2016a, 2016b, 2016c, 2017, Nistor 2007). In this article, multi-resolution analysis and non-linear ordering were used to classify groups in three time categories. These two tools were combined to create an unconventional algorithm. The wavelet analysis allowed us to examine the pace of the development of globalization in countries of the European continent over various time trends.



## LITERATURE:

1. Dreher, A., & Gaston, N. (2007). Has globalisation really had no effect on unions?. *Kyklos*, 60(2), 165-186.
2. Dreher, A., Gaston, N., & Martens, P. (2008). *Measuring globalisation: Gauging its consequences*. Springer Science & Business Media.
3. Gygli, S., Haelg, F., & Sturm, J. E. (2018). The KOF Globalisation Index–Revisited. *KOF Working Papers*, 439.
4. Hadaś-Dyduch, M. (2015a): Prediction of wavelets analysis. In *Financial management of Firms and Financial Institutions, Proceedings (Part I.) 10th International Scientific Conference* . pp. 341-348.
5. Hadaś-Dyduch, M. (2015b). Polish macroeconomic indicators correlated-prediction with indicators of selected countries. In *Proceedings of the 9th Professor Aleksander Zelias International Conference on Modelling and Forecasting of Socio-Economic Phenomena* (pp. 68-76). Foundation of the Cracow University of Economics, Cracow.
6. Hadaś-Dyduch, M. (2015c). *Wavelets in Prediction: Theory, Method, Simulation*. Scholars' Press.
7. Hadaś-Dyduch, M. (2016a). Econometric-wavelet prediction in spatial aspect. In *The 10th Professor Aleksander Zelias International Conference on Modelling and Forecasting of Socio-Economic Phenomena*. Conference Proceedings. Cracow: Foundation of the Cracow University of Economics. pp. 45-52.
8. Hadaś-Dyduch M. (2016b). Globalization in the context of cointegration selected countries. *16th International Scientific Conference Globalization and Its Socio-Economic Consequences, Conference Proceedings*. University of Zilina. The Faculty of Operation and Economics of Transport and Communication. Department of Economics. pp. 587-594.
9. Hadaś-Dyduch, M. (2016c). Model–spatial approach to prediction of minimum wage *International Scientific Conference on Quantitative Methods in Economics - Multiple Criteria Decision Making XVIII*. Conference Proceedings. Vratna, Slovakia. pp.134-138.
10. Hadaś-Dyduch, M. (2017). Analysis of globalization by wavelets through the prism of selected Euro Area Countries. In *17th International Scientific Conference Globalization and Its Socio-Economic Consequences*, University of Zilina, 4th–5th October 2017 Rajcke Teplice, Slovak Republic, pp. 605-612 (part II).
11. Nistor, C. (2007). Positive and Negative Effects of Globalization. *Universitatii Bucuresti. Analele. Seria Stiinte Economice si Administrative, 1*, 152.
12. Olteanu, A., & Radoi, M. A. (2010). Positive and Negative Effects of Globalization. *Lex ET Scientia Int'l J.*, 17, 209.

## WHY REVENUES FROM PAYROLL TAXES DO NOT FOLLOW TRENDS IN TAXATION OF INCOME OF CORPORATIONS?

**Andrzej Karpowicz**

*Bialystok University of Technology, Management Engineering Faculty,  
Financial and Accounting Department, Poland  
a.karpowicz@pb.edu.pl*

### **ABSTRACT**

*Tax competition is commonly believed to erode revenues from taxes. Further to the literature this concerns in particular income taxes. However, despite increasing globalization processes, according to empirical data for EU Member States the revenues from income taxes have provided for comparable inflows to state budgets over the last years. Moreover, the volatility of revenues of income taxes over time is generally low. Interestingly, in general changes in size of revenues from corporate income tax do not follow trends for payroll taxes. This suggests that receipts from those two kinds of taxes are determined (i) either by separate factors or (ii) the causes are the same but they act in opposite direction. As a result the importance of widely discussed matter of tax competition is questionable or understanding of its influence should be redefined. As an attempt to explain the diverging behavior of corporate and personal income tax revenues I present in this article some remarks on origins such developments.*

**Keywords:** *Income Tax, National Budget, Public Finance, Revenue, Taxation*

### **1. INTRODUCTION**

One the key objectives of fiscal policy is increasing (or at least maintaining) welfare of the society. Public goods play a role in this respect. However, in order to finance them, receipts from taxes are required. Eventually, the primary function of any kind of tax is fiscal. Changing economic conditions - that include increasing tax competition among states - need to be faced to assure such income on satisfactory level. Even assuming that welfare is directly connected only with public goods, Hines concludes that tax competition does not necessarily affect social welfare. The reason is that, as evidence shows, the corporate income tax (hereinafter: "CIT") revenues (which are claimed to be particularly prone to erosion) in the OECD countries in the period 1992 - 2004 remain roughly stable (Hines, 2006). Over more than ten years from publication of this article the exposure to tax competition in globalizing market was on rise. Yet, the amount of sources used for financing of public goods are on a comparable level. Thus, the economic theory does not fully match the practice. Hence, the question whether tax competition actually leads to too little budget inflows is still open. Taxes including social security contributions are the key source of revenue of EU Member States. On average in the period 1995 – 2016 they provided for 86 percent of budget revenues of those set of countries. This figure varied from 78 percent for Bulgaria to 92 percent for Belgium. However, overall during this period taxes provided for relatively stable fiscal inflows. They fluctuated between 38.3 percent of GDP, which was recorded in 2009 to the highest value of 40.2 percent of GDP in 1999 with the mean of 39.2 percent of GDP for the considered time span. For details please refer to the below figure.

*Figure following on the next page*

Figure 1: Total receipts from taxes and social contributions for EU Member States (before the accession of Croatia) for the period 1995 – 2016; Own calculations based on data from Eurostat

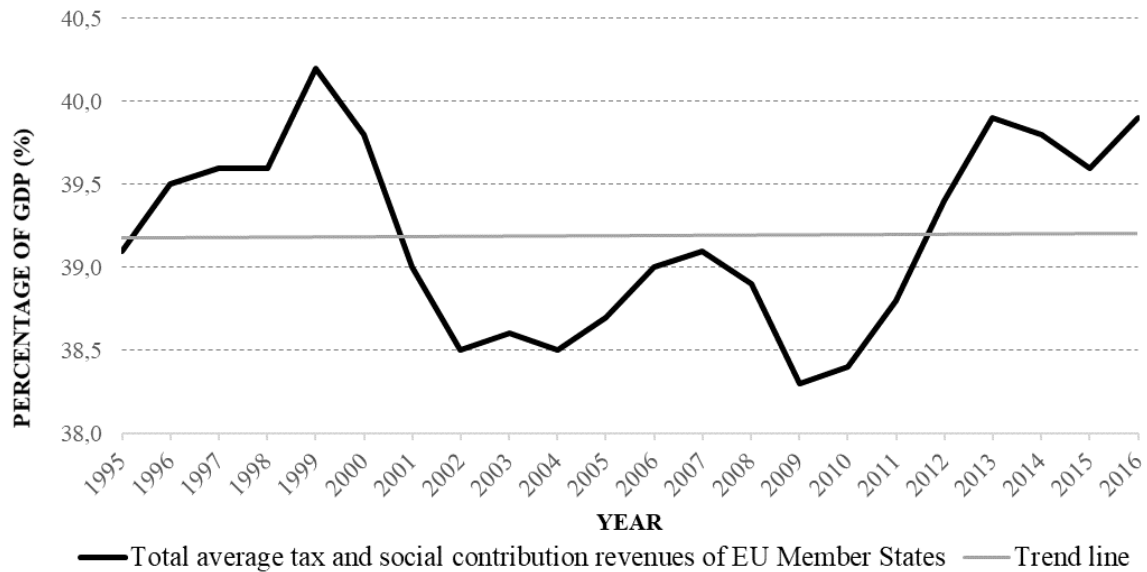

It strikes that the estimated trend line is horizontal. This confirms that in the long term the revenues from all taxes or social security contributions are comparable. The standard deviation is just 0.5 percentage point, which means that the variability is modest. More interesting could be the composition of those revenues. Eventually, each EU country imposes several taxes on various objects or taxation subjects. They include primarily value added tax, excise duty, corporate and personal income tax (hereinafter: "PIT") or social security contributions. The aim of this article is to track the long term trends in terms of provision of budget revenues from different taxes based on aggregated data. Particular attention is put to income taxes including social security contributions. I seek also to explain the reasons for variability of budget inflows from these sources. In the following section I present the sources of data and methodology used. This is followed by analysis of the considered issue, which is made in four subsections dealing with general information on taxation trends in terms of tax competition, available schemes of tax competition, whereas particular attention is put to CIT, PIT and social security including budget revenues from these sources. Finally, the results are discussed and conclusions made.

## 2. DATA AND METHODOLOGY

The aim of this article is to provide for universal findings in terms of the causes of the pattern of long run development of budget revenues from different kinds of taxes. I conduct the analysis primarily in qualitative manner. I draw conclusions based on scientific and practical experience in taxation matters. This is accompanied by relevant literature, which is reviewed and commented. Although, the existing literature is used in this analysis, but the findings of these past research in several cases is used for interpretation of phenomena not discussed previously. I support the research with some basic quantitative analysis referring to statistical data as described below. I decided to refer to particular set of countries for numerical empirical analysis. I used a sample of EU Member States. Calculations are made on aggregated data. Therefore, I excluded Croatia from the sample, as it accessed EU in 2013 and as a result the statistical figures are not complete for earlier periods to some degree. The considered analysis is referred primarily to EU mainly due to statistical reasons that include: (i) completeness of data for each analysed country, (ii) availability of wide selection of data, (iii) considerable possibilities of tailoring the data according to user demand, (iv) comparability of data between

countries due to standardized calculation procedures, (v) similar tax system and existence of key taxes in each country, (vi) relative homogeneity of sample both in terms of economic development and geographical proximity, and finally (vii) good quality of data sources in general. The complete empirical data for the EU Member States is available for the period 1995 - 2016. Therefore, such time-span for analysis is adopted. The data is sourced from Eurostat. Total tax revenue is understood as “Total receipts from taxes and social contributions (including imputed social contributions) after deduction of amounts assessed but unlikely to be collected”, which refers to label D2\_D5\_D91\_D61\_M\_D611V\_D612\_M\_M\_D613V\_D614\_M\_D995 in Eurostat classification. Other commonly aggregates include (i) D5 - Current taxes on income, wealth, etc. and (ii) D61 - Net social contributions. These two more detailed sets build considerable part of the value of “Total receipts from taxes and social contributions (...)” referred to above. The composition of these aggregates are as follows:

- D5 - Current taxes on income, wealth, etc. are composed of taxes on income (both corporate and individual/household income), real estate tax connected with capital or inheritance and donation tax as well as other similar taxes, which have lesser importance for rising budget revenues and therefore are not specified here.
- D61 - Net social contributions comprise generally of social security charges.

These aggregates are not fully relevant for the considered analysis without some preliminary adjustment. Therefore, I made modification with respect to income taxes and social security contributions. The necessity for such alteration results from the fact that Eurostat includes in the category of D5 - Current taxes on income, wealth, etc. both (i) “Taxes on individual or household income including holding gains” categorized under the label of D51M and (ii) “Taxes on the income or profits of corporations including holding gains” labelled D51O. In reality they refer primarily to PIT or CIT. Therefore, as these are two other kinds of taxes I recognize them separately. Moreover, according to Eurostat standard methodology Social security is presented as a separate source of tax revenues (D61 - Net social contributions). In fact as social security is collected from workers remuneration it should be considered along with PIT. Eventually, they are both payroll taxes. Therefore, for the purpose of any calculation I consider in this article revenues from social security and revenues from PIT altogether. In some cases the figures are expressed as a percentage of GDP of each state/EU. Such approach provides for comparability of tax revenues among different states.

### **3. TAX COMPETITION AND TAX REVENUES**

#### **3.1. General considerations**

The matter of tax competition and tax revenues was initially considered by economists based on the data for US market. This was connected inter alia with good availability of empirical data. Subsequently, the analyses focused more on OECD countries. Eventually, the EU as a system of economies, which could face further fiscal integration, is recently of interest. In terms of taxation globalization is strictly connected with tax competition. It originates from rivalry for capital between the USA and Europe. The developments of tax rates in the USA can be explained to some extent on the example of US economy. After the World War II USA was the most important global economy and thus it was able to set standards also in the area of taxation. Imposing high tax rates did not trigger there outflow of capital. Other countries followed the US pattern of high tax rates, as they did not need to anticipate outflow of capital either. The reason was that the rates in the USA were not competitive. The situation has been changing since the mid-80s. The role of the US economy has started to decrease. US government responded in lower tax rates. Consequently, other countries found themselves under pressure to cut the tax rates to maintain the competitiveness of own economies. The stage of globalization that is believed to have direct impact on tax revenues can be well observed

based on globalization index published by ETH Zurich. Whereas in 1970 the value of index for the world was just below 40, in 2015 it exceeded 60. The fear of outflow of mobile capital resulted in the so called “race to the bottom” hypothesis. Particularly exposed to tax competition is CIT. Some researchers even questioned the reasons for its existence ( (Gordon, 1992), (Weichenrieder, 2005), (de Mooij, 2005), (Sørensen, 2007)). This on the other hand raised concerns of the ability of governments to redistribute income and finance public goods ( (Lee & McKenzie, 1989), (Hicks & Swank, 1992)). Yet, usually the studies provided also arguments in favour of CIT. Slemrod in his cross country analysis found that measures of openness of the economies are positively associated with the statutory CIT rates (Slemrod, 2004). He observed that more trade-intensive countries collect higher CIT revenues. He explained it by higher on average investment attractiveness of such countries. Some other studies stated that the “race to the bottom” hypothesis does not correspond to the reality ( (Quinn, 1997), (Hays, 2003), (Basinger & Hallerberg, 2004)).

### **3.2. Tax rate versus tax base competition**

Tax competition is often associated with the level of taxation rates. Indeed, Devereux and Griffith, acknowledge that countries can compete for mobile capital two way using basic methods given by tax law – primarily by (i) reduction in tax rates and by (ii) shrinking of the legal tax base (Devereux & Griffith, *Taxes and the Location of Production: evidence from a panel of US multinationals*, 1998). However, it seems that statutory tax rate reductions are more effective than tax base shrinkage. There are some arguments in favour of this claim:

1. tax rate is easily observable by the investors and more appealing to them. The scope of legal tax base is much more burdensome to define and hence investors have difficulties in observing the differences in this respect between the states. Thus, the countries use the fact that the picture of the tax base is blurred and therefore tax competition in this respect, if any, is very limited. A tax rate reductions send a much stronger competitive signal to investors than the tax base narrowing (Ganghof, 1999).
2. broad tax base usually reduces the tax compliance and administration costs. This is based on the assumption that broad tax base, in opposition to a narrow tax base, provides for less exemptions or allowances. Fewer modifications of the accounting profit make the taxable income easier to calculate for the firm and pay the tax in an appropriate amount. Simple tax rules are also advantageous for tax authorities, which perform tax audits.
3. narrow tax base - unlike low statutory tax rate - does not offer protection from profit shifting or outflow of capital ( (Zodrow, 2006), (Genschel & Schwarz, 2011), (Janik & Paździor, 2014)). Consequently, governments broadened tax bases while reducing the tax rates as this should limit the tax avoidance.
4. tax rates are distortive and produce a deadweight loss to the square of their level as the size of the deadweight loss is  $\frac{1}{2}T^2pqn$ , where T is the tax rate.
5. pressure on low tax rates is beneficial for firms subject to local income tax, which with lesser distortions are able to face fierce international competition (Zodrow, 2006).
6. finally, the statutory rate is - according to empirical studies - the most important determinant of effective tax burden of corporations (European Commission, *Company Taxation in the Internal Market*, 2001) and high income individuals (PricewaterhouseCoopers & ZEW, 2005).

Thus, it is more reasonable to increase the size of the legal tax base and lower the tax rate than the other way round. For example Devereux et al., who made the analysis for United Kingdom, claimed that among the most important determinants of CIT receipts is legal tax base broadening (Devereux, Griffith, & Klemm, *Why has the UK corporation tax raised so much revenue?*, 2004).

Overesch and Rinckle show that indeed the European countries seem to compete primarily over statutory rates rather than over effective rates (Overesch & Rincke, 2011). This can be explained by the fact that although recently countries cut the statutory CIT rates, they were concurrently involved in legal tax base broadening processes. The effective average tax rate (hereinafter: "EATR"), unlike the statutory one, encompass the fact of tax base broadening. EATR is computed by applying some of the basic tax rules included in a tax law of particular country to a hypothetical investment. It takes into consideration a number of features of the tax system, including the statutory tax rate, capital allowances, the treatment of interest deduction, the allowance for corporate equity, the treatment of foreign source income, wealth taxes paid by the company, as well as the treatment at the corporate and personal level of dividends paid by the company, and wealth and capital gains taxes at the personal level. The EATR decreased over the last years less than the statutory CIT rate. For graphical interpretation of recent data please refer to the below figure.

*Figure 2: Average top statutory CIT rates and EATR for EU Member States; Own conceptualization based on data from (European Commission, Taxation Trends in the European Union, 2013) and (European Commission, Taxation Trends in the European Union, 2018); due to lack of complete data EATR for the years 2006 and earlier periods are presented for 25 EU countries only (i.e. without Romania, Bulgaria and Croatia, which accessed the community in 2007 or 2013, respectively)*

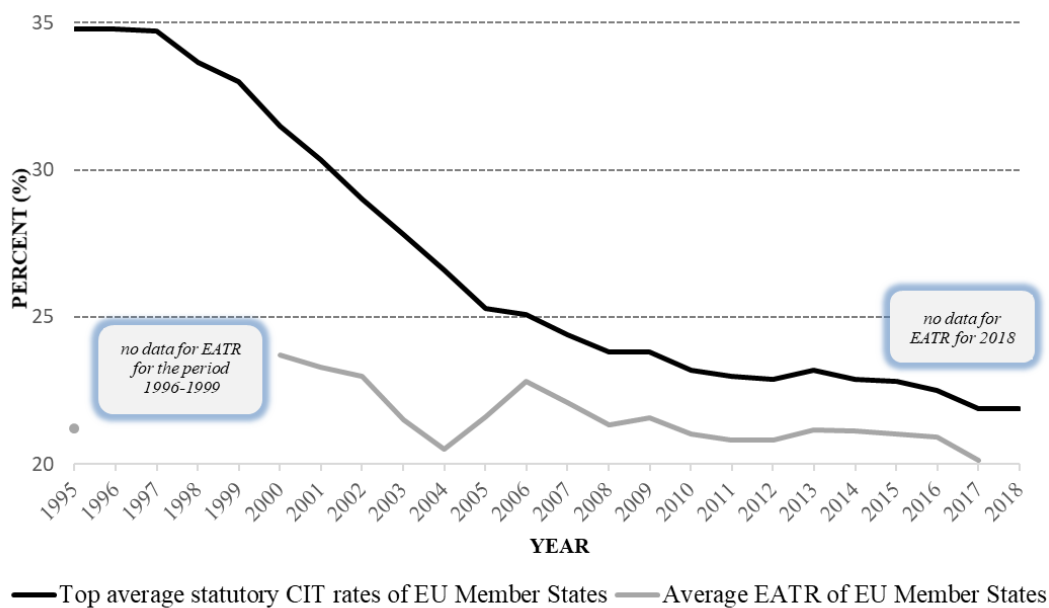

EATR for EU countries have fallen over the last decade largely in line with the drop in the CIT rate. The data for the last decade show that a stabilisation around the 20 percent and 21 percent level has been achieved. For the year 2017 it was 20.1 percent, whereas legal CIT rate was at that time on average just a 1.8 percentage point higher. Yet for the earlier periods the discrepancy was higher. In 1995 it exceeded 13.5 percentage points. This suggests that indeed Member States put pressure on broadening of the tax base. In other words, although the CIT rate decreased considerably from almost 35 percent in 1995 to less than 22 percent in 2017, the effective tax rate remained on comparable level for the whole period. Regrettably, such analysis is not available for payroll tax, where no effective tax rate is available. Nevertheless, PIT legislation follows generally that of CIT. Therefore, it can be assumed that tax base for PIT follows that set for CIT. Consequently, the above considerations should hold also for payroll taxes.

### **3.3. Other tax competition methods**

Genschel and Schwarz, add to the tax competition measures also those not connected directly with the tax law – i.e. (iii) relaxation of tax enforcement and (iv) restrictions in sharing the tax information with third parties (Genschel & Schwarz, 2011). Lax tax law enforcement including limited monitoring of tax collection by the tax authorities certainly also reduces effective tax rates. However, this is made through increased possibilities of tax evasion. From the perspective of a state such approach may not be clever as the economic agents would have difficulty in assessment of the actual effective tax rate. Moreover, even if they would be able to estimate such rate, this appraisal would involve uncertainty. Taxpayers would always be exposed to some financial risk of being audited by tax authorities whereas such audit may challenge some operations and categorise them as tax evasion subject to penalty. In addition low effectiveness of tax administration - even if made on purpose - may suggest that the quality of public administration in a country is questionable. Yet, there might be cases, when such approach is the only way the tax competition may be pursued. Some researchers claim that tax harmonization in the EU, both regarding tax rates and tax bases may not leave other options for local governments as to lax the tax law enforcement (Smith, 1997). Countries may reduce the effective tax rates also by introducing strict secrecy provisions, which is the fourth point from the above list of tax competition measures. Tax evaders would then be tempted to locate in a state, where their income earned would be concealed before the tax authorities of the home country. Consequently, they will pay only the tax at source (if any). The prominent example in this respect is Switzerland, where it is generally illegal for banks to share the information on their customers with third parties including government. In case of Switzerland this mechanism connected with low tax rates proved to be highly effective. Countries imposing tax on a source basis may not be interested in providing information to other governments on the income earned at source by foreign parties. Sharing information decreases tax competitiveness of such a country and foreign economic agents do not perceive it as a tax heaven. Such strategy of tax competition does not require the competing country to surrender any part of potential taxable income (which would be the case if the tax rate is cut, tax base is narrowed or tax law enforcement is less strict). Consequently, the additional tax revenues are gained fully at the expense of foreign countries. Therefore, countries enforcing strict secrecy law are under growing pressure of other states, which accuse them of hiding the tax evaders. Other, so called soft methods of tax competition, are also available. Among them are for example (v) simplification of the tax system, which reduce the compliance costs, (vi) easier access to tax administration, which treats the taxpayer as a customer, who acquires public services and finances them with taxes or (vii) reduction of tax uncertainty e.g. by granting the possibility to secure the transaction a priori by collecting applicable tax ruling, which eliminates the tax risk etc.

### **3.4. Development of tax revenues from payroll taxes and CIT**

Both CIT and payroll tax are similar levies in term of their nature. Either of them is calculated by multiplication of the statutory tax rate and taxable income (with some modification for Social security depending on jurisdiction; but as explained in section on data and methodology, I believe that they should be regarded altogether). However, they behave very differently. This can be observed based on the below figures.

*Figure following on the next page*

Figure 3: Average revenues from payroll taxes and CIT for EU Member States; Own conceptualization based on Eurostat

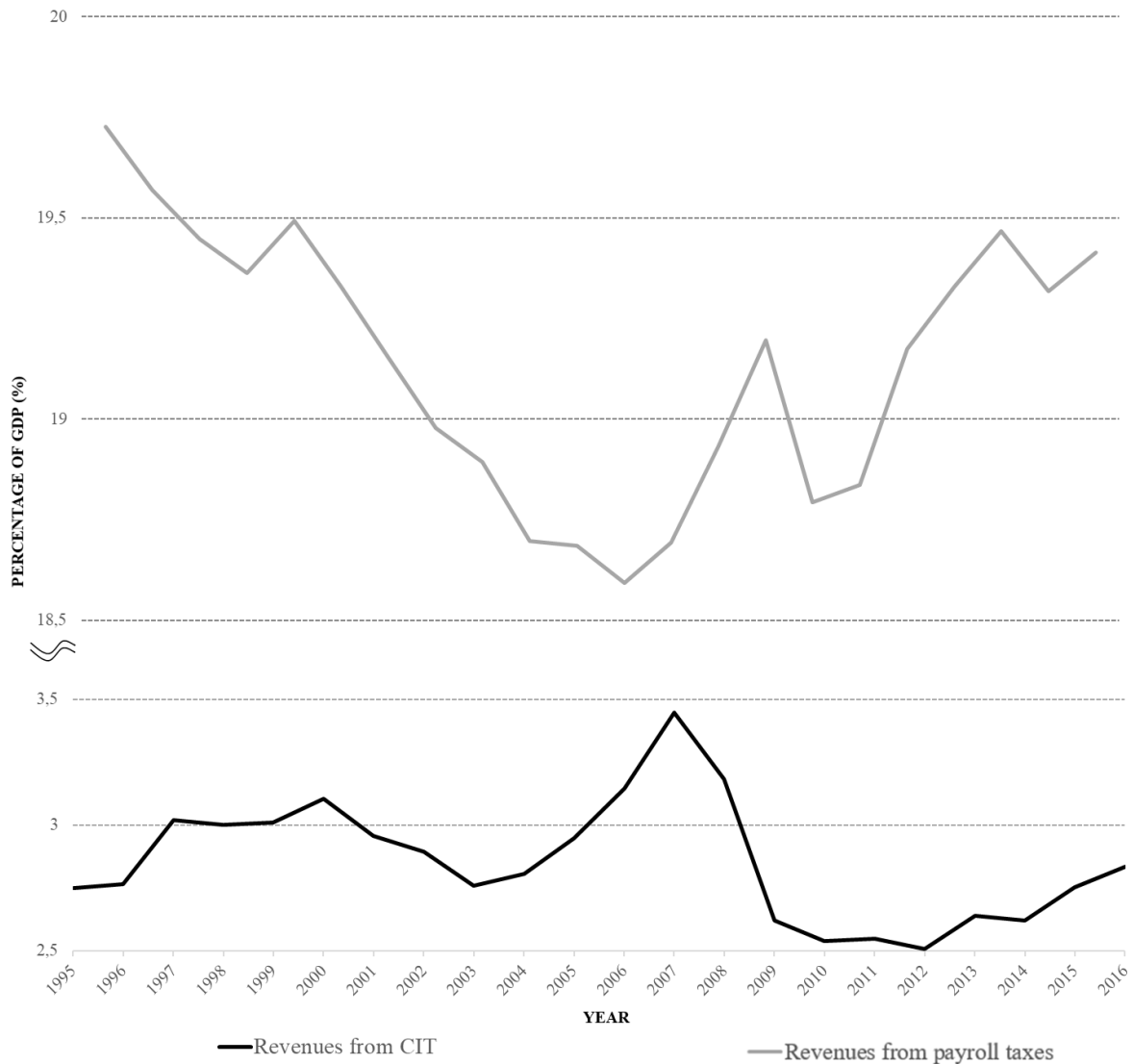

From 1995 the CIT revenues were generally increasing and reached all time high of 3.5 percent of GDP in 2007. Concurrently, budget income from payroll taxation (which I calculated by totalling PIT revenues for particular country/year with Social security contributions) was decreasing in that period and all-time low of 18.6 percent was recorded in 2006. Then for next three years a sharp increase was recorded. At the same time receipts from CIT were falling rapidly. The trend for those taxes is relatively similar for recent years only. Therefore, it suggests, that the determinants of revenues from CIT vs payroll taxes are generally either (i) different or (ii) the same but induce diverging impact. Without doubt the two most obvious factors that impact revenues from both those taxes (and hence belong to group (i) noted above) are legally set tax base and tax rate. Based on brief analysis made earlier in this article it seems that the tax bases with respect to CIT as well as to payroll taxes have been continuously broadening. Moreover, we know clearly that the tax rates have been generally decreasing for both analysed taxes too. Thus, it may seem that both (i) tax rate and (ii) breadth of the legally set tax base should impact receipts from CIT and payroll taxes similarly. In other words falling tax rate should result in decreasing CIT and PIT/Social security revenues, whereas broadening legal tax base probably has opposite effect. For example Riedl and Rocha-Akis, who worked on data for 17 OECD countries for the period 1982 – 2005 confirmed this relation (Riedl &



Rocha-Akis, 2012). Other researchers arrived at similar results [e.g. (Devereux M. P., Developments in the taxation of corporate profit in the OECD since 1965: Rates, bases and revenues, 2007) or (Kubatova & Rihova, 2008)]. Of course such assumption would be to bold, without knowing the exact sensitivity of those taxes to changes in tax rate/tax base. However, according to the research made by Clausing, who based on empirical data for OECD countries for years 1979 - 2002, the impact of CIT rates on tax revenues is strong and robust but non-linear. She calculated that the revenue maximizing rate is 33 percent (Clausing, 2007). Devereux, who also focused on OECD countries, calculated that the revenue maximizing rate is a bit lower i.e. 30 percent (Devereux M. P., Developments in the taxation of corporate profit in the OECD since 1965: Rates, bases and revenues, 2007). However, the results he arrived at are not significant and hence he concluded that there is no systematic relation between CIT rates and tax revenues across OECD countries. However, both studies largely confirm that there exists a tax rate, which further increase leads to a fall in tax revenues. As the average top CIT rate for 2018 in EU Member States is 21.9 percent – and hence by far lower than those values – we may accept that the claim made above on positive relation of tax rate and tax revenues holds in reality. I assume that this condition holds also for PIT. The reason is that although the average top PIT rate is 39 percent for EU Member States, this is the value applicable to top income bracket, whereas vast majority of population is taxed according to lower rates. Moreover, as labour is less mobile, then the budget revenues maximizing rate must be higher than for CIT. It should be admitted that to get a full picture Social security rate should be compounded to arrive at some artificially calculated payroll rate. However, such calculation would be very demanding and could be a subject for further research. With respect to the tax base (which is second legally set determinant of tax revenues), the impact on CIT and payroll taxes must be also the same (i.e. the broader the tax base, the higher CIT/payroll revenues). As the significance and behaviour of breadth of the tax base is similar to the tax rate level, the analysis made above for the tax rate is also applicable here. The above analysis does not provide us for explanation on the reasons of diverging behaviour of CIT and payroll revenues. Thus, the question arises on other determinants of CIT and payroll budget inflows. Now we will focus on those not directly linked to legislation. One of the key determinants discussed already above is capital mobility. Tax competition seems to rise with mobility of capital. Therefore, the tax competition concerns primarily CIT. However, globalization of world economies and spreading ideas of low tax rate level has direct impact on PIT as well. Nevertheless, labour force subject to payroll taxes is less mobile and it is difficult (or even impossible) to report it for taxation in another country. For example with respect to work force taxation the studies show that migrations are primarily income-driven and not tax-driven. Workers change location in search for better jobs and higher wages and only rarely due to lower taxation. In addition, PIT is often imposed also on firms operating in form of sole-proprietorships or partnerships. However, companies operating internationally are usually bigger and the share of firms organized in corporate form rises with the size of the business. Thus, as mobile capital is connected with companies rather than partnerships or sole-proprietorships, CIT is more affected by international openness than PIT. Furthermore, if capital is mobile, then it needs to exit from investments relatively fast. Sole-proprietorships are not transferable, whereas sale of partnerships is more burdensome than sale of shares of a company. Thus, mobile capital should engage more in corporate than non-corporate sector to assure higher mobility. The above is reflected inter alia in the empirical research performed by Winner, who analysed the influence of capital mobility on the tax burden based on the panel data for 23 OECD countries for the period 1965 – 2000 (Winner, 2005). For the purpose of his model he defined the capital mobility as the absolute difference between domestic savings and investments related to the output  $\frac{|S^D - I^D|}{Y}$ . He estimated that a one percentage point increase in capital mobility means a decrease of CIT burden by 0.18 percentage points (measured according to the concept of average

effective tax rates). Concurrently, capital mobility have positive impact on the labour tax burden. A one percentage point increase in capital mobility transforms into increase of the labour tax burden by 0.07 percentage point. This means that in fact countries, which struggle to tax mobile capital with CIT seek to tax less mobile labour with higher PIT, where globalisation may induce even positive effects on revenues from this tax. Indeed the top statutory PIT rates have not been constantly decreasing over the last years. For details please refer to the below graph.

*Figure 4: Average top statutory PIT and CIT rates for EU Member States; Own conceptualization based on data from (European Commission, Taxation Trends in the European Union, 2013) and (European Commission, Taxation Trends in the European Union, 2018)*

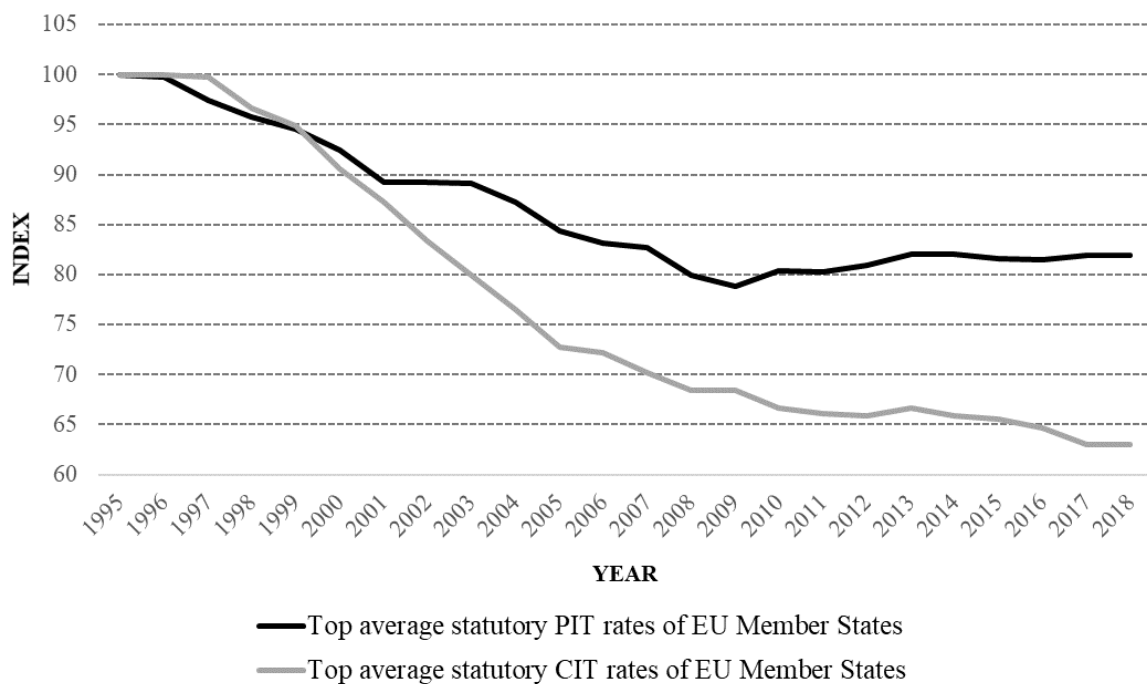

The above figure suggests that indeed top statutory rates for corporations have been falling more rapidly than for personal taxation. Over the analysed period CIT rates decreased by roughly 38 percent, which is exactly twice as much as in case of PIT. Becker and Fuest, who analysed the CIT revenues in German states, also observed that there is a positive relation between internationalization and CIT revenues (Becker & Fuest, 2010). They suggest that the advantage of multinational firms in profit shifting is overestimated. Moreover, they conclude that national firms have also possibilities to shift profits to non-corporate sector. This assumption is true but in practice seems, not quite robust. The reason is that usually CIT rates correspond to the PIT rates in a particular country. In other words, usually if CIT rates are high in certain jurisdiction, then the PIT rates are elevated as well. Thus, the incentive to shift profits within single state from a company to a non-corporate sector is limited. This is the case also in Germany. Therefore, the results Becker and Fuest arrived at are rather connected with agglomeration externalities, which are the key incentive for investors. As German states do not differ considerably in respect of income taxation, such results may be also applicable for other countries including EU as a whole. However, the conclusions from this analysis cannot be simply used for group of countries because there is no possibility of profit shifting among German states (unlike in case of cross-border transactions). This is because the profits are taxed by local German states according to appointment formula depending on the payroll.

Summarising, the effect of capital mobility – discussed here and before in this article – seems to have other influence on tax revenues from CIT and payroll, which to some extent grounds different behaviour of inflows from those taxes (as depicted on the figures above). Secondly, multinational firms are probably also more profitable than local companies, which means that the tax base for CIT increases along with internationalization. Auerbach and Poterba, who analyzed the data for US market, found that the corporate profitability is the most important determinant of CIT receipts (Auerbach & Poterba, *Why have corporate tax revenues declined?*, 1987). Douglas, who analyzed the reasons for declining importance of CIT receipts in Canadian budget in the period 1960 – 1985, also found that the falling profitability of companies was the key reason for decline of CIT receipts (Douglas, 1990). Devereux et al. claimed that the most important determinants of CIT inflows include profitability of companies and especially that of financial institutions (Devereux, Griffith, & Klemm, *Why has the UK corporation tax raised so much revenue?*, 2004). Karpowicz and Majewska found that corporate income tax revenues depend inter alia on GDP growth, which was used as a proxy for corporate profitability (Karpowicz & Majewska, 2018). Internationalization supports better allocation of resources and usually allows for higher degree of specialization. This finds evidence in empirical literature (e.g. (Edwards, 1997), (Walicka, 2012)). It may also happen that firms with above average profitability decide to go international, which supports the correlation between internationalization and profitability of the corporate sector. Some explanation is also that local tax administration presumably examines multinational firms more thoroughly than domestically-owned. Therefore, although the tax law in a given jurisdiction is the same for all entities the increased frequency of tax audits in foreign-owned companies may motivate those taxpayers to reveal all taxable incomes, which transforms into higher business tax revenues. Concurrently, the profits reported to taxation should have similar impact on CIT and payroll revenues. Yet, individuals have limited possibilities to shift profits to other jurisdictions. Thus, the level of internationalization cannot be discussed with respect to taxation of citizens. As a result, this is an additional argument for diverging developments of CIT and payroll revenues. The third issue is the right to offset tax losses. For example German parent companies are entitled to offset tax losses against profits earned by other local subsidiaries. Such scheme is not available in a number of EU Member States (which among others include Poland). Usually, tax losses can be offset against taxable income only within single company. In particular, foreign companies located in one EU country and with subsidiaries in another Member State cannot offset their tax losses against headquarters income. According to the studies for the US market Auerbach argued that legal restrictions in the offset of tax losses explain significantly rising CIT revenues (Auerbach, *Why Have Corporate Tax Revenues Declined? Another Look*, 2006). The considered matter also explains the higher tax base among multinational taxpayers. Summarizing, the right to deduct tax losses from previous years from current taxable profit results overall in smaller revenues reported by the firms that are subject to CIT in the EU. If such right was restricted, the CIT revenues would be higher (*ceteris paribus*). Within payroll it is simply not possible to incur tax loss. The lowest level is simply no income (and hence no tax). Income subject to payroll tax is never negative (I do not consider now partnerships or any other entities with are transparent for tax purposes and hence may be subject to PIT). Therefore, impact of right to deduct tax losses on tax revenues from CIT and payroll is diverging, which partially explains opposite developments in terms of revenues from those taxes. To those arguments we should add several issues that directly impact revenues from payroll, but generally have no effect direct on receipts from CIT. They include for example employment understood as a proportion of the total number of people employed and the total number of working-age people. The increase of employment rate naturally transfers in surge in PIT receipts. Similar effect evokes population growth or decrease in unemployment rate.

Increase in level of wages paid out should support inflows payroll taxation but at the same time put pressure on CIT revenues. These issues has been analysed in more detail in terms of impact on revenues from PIT by several researchers (e.g. (Tosun, 2006), (Goudswaard & van de Kar, 1994), (Andrejovská, Bánociová, & Glova, 2018)).

#### 4. CONCLUSIONS

Different performance of CIT and payroll revenues over time is a fact that rarely is noticed by the policy makers. The aim of this brief analysis it to put more attention to this fact. My attempt was also to try to explain – at least in part – this phenomena. It seems that the diverging behaviour in terms of size of CIT and payroll revenues is determined concurrently both by (i) similar factors that evoke contradictory effects and by (ii) separate determinants. The first set of stimulants includes globalization. Whereas globalization or capital mobility may destroy inflows from CIT, at the same time it supports revenues from payroll taxes. The second group includes profitability of companies connected with their international growth. This issue concerns CIT only. Internationalization may have positive impact on revenues from this tax. Concurrently, such influence is questionable in case of payroll taxes, where by definition individuals who earn wages subject to payroll tax could be rarely perceived as taking part in internationalization of engagements. The possibility of offsetting of tax losses is also the matter that concern CIT but does not apply to payroll taxes. Therefore, whereas the right to use tax losses from previous periods decrease the CIT to be paid now, for payroll such tool is not available. Finally, there are factors that directly influence the tax base (this time not legally set) prima facie for payroll purposes. This group includes employment rate, population size changes, unemployment rate level or amount of wages paid out. The set of matters mentioned above that impact CIT or payroll revenues are certainly not complete and further analysis is required. However, it seems that particular attention should be put on payroll matters. This is because the revenues from payroll in most states is more important in terms of value to the local government budget then receipts from taxation of income of corporations. Therefore, analysis in this respect –also of quantitative nature - seems vital not only from scientific but primarily from practical perspective.

#### LITERATURE:

1. Andrejovská, A., Bánociová, A., & Glova, J. (2018). Employment as a macroeconomic factor that impacts tax revenues. *Scientific Journal of Polish Economic Society in Zielona Góra*.
2. Auerbach, A. J. (2006). Why Have Corporate Tax Revenues Declined? Another Look. *NBER Working Papers, 12463*.
3. Auerbach, A. J., & Poterba, J. M. (1987). Why have corporate tax revenues declined? *NBER Working Paper Series, 2118*.
4. Basinger, S. J., & Hallerberg, M. (2004). Remodelling the Competition for Capital. How Domestic Politics Erases the Race to the Bottom. *American Political Science Review, 98*(2), pp. 261-276.
5. Becker, J., & Fuest, C. (2010). Internationalization and business tax revenue—evidence from Germany. *International Tax and Public Finance, 17*(2), pp. 174-192.
6. Clausing, K. (2007). Corporate tax revenues in OECD countries. *International Tax and Public Finance, 14*(2), pp. 115-133.
7. de Mooij, R. A. (2005). Will Corporate Income Taxation Survive? *De Economist, 153*(3), pp. 277-301.
8. Devereux, M. (2008). Effective levels of company taxation within an enlarged EU. *Project for the European Commission (TAXUD/2005/DE/3 10), ZEW*.

9. Devereux, M. P. (2007). Developments in the taxation of corporate profit in the OECD since 1965: Rates, bases and revenues. *Working Papers, 0704*.
10. Devereux, M. P., & Griffith, R. (1998). Taxes and the Location of Production: evidence from a panel of US multinationals. *Journal of Public Economics, 68*, pp. 335-367.
11. Devereux, M. P., Griffith, R., & Klemm, A. (2004). Why has the UK corporation tax raised so much revenue? *Fiscal Studies, 25*(4), 367–388.
12. Devereux, M., & Griffith, R. (1999). The Taxation of Discrete Investment Choices. Revision 2. *IFS Working Paper*.
13. Devereux, M., & Griffith, R. (2003). Evaluating Tax Policy for Location Decisions. *International Tax and Public Finance*.
14. Douglas, A. V. (1990). Changes in Corporate Tax Revenue. *Canadian Tax Journal*, pp. 66-81.
15. Edwards, S. (1997). Openness, Productivity and Growth: What Do We Really Know? *NBER Working Paper, 5978*.
16. European Commission. (2001). Company Taxation in the Internal Market. *Commission Staff Working Paper*.
17. European Commission. (2013). *Taxation Trends in the European Union*.
18. European Commission. (2018). *Taxation Trends in the European Union*.
19. Ganghof, S. (1999). Adjusting National Tax Policy to Economic Internationalisation: Strategies and Outcomes. *MPIfG Discussion Paper*.
20. Genschel, P., & Schwarz, P. (2011). Tax competition: a literature review. *Socio-Economic Review, 9*, pp. 339-370.
21. Gordon, R. H. (1992). Can Capital Income Taxes Survive in Open Economies? *The Journal of Finance, 47*(3), pp. 1159-1180.
22. Goudswaard, K., & van de Kar, H. (1994). The impact of demographic change on tax revenue. *Atlantic Economic Journal*.
23. Hays, J. C. (2003). Globalization and Capital Taxation in Consensus and Majoritarian Democracies. *World Politics, 56*(1), pp. 79-113.
24. Hicks, A. M., & Swank, D. H. (1992). Politics, Institutions, and Welfare Spending in Industrialized Democracies, 1960-82. *The American Political Science Review, 86*(3), pp. 658-674.
25. Hines, J. R. (2006). Will Social Welfare Expenditures Survive Tax Competition? *Oxford Review of Public Policy, 22*(3), pp. 330-348.
26. Janik, W., & Paździor, M. (2014). Rola podatku dochodowego od osób prawnych w tworzeniu dochodów budżetowych i rozwoju przedsiębiorstw. *Engineering Management in Production and Services*.
27. Karpowicz, A., & Majewska, E. (2018). Corporate income tax determinants: how important is the tax rate? *Economic and Social Development: Book of Proceedings; Varazdin*.
28. Kubatova, K., & Rihova, L. (2008). Factors affecting revenues from corporate tax. *Structural Distortions of Taxation and Investment Decision*. Czech Science Foundation.
29. Lee, D. R., & McKenzie, R. B. (1989). The International Political Economy of Declining Tax Rates. *National Tax Journal, 42*(1), pp. 79-83.
30. Overesch, M., & Rincke, J. (2011). What Drives Corporate Tax Rates Down? A Reassessment of Globalization, Tax Competition, and Dynamic Adjustment to Shocks. *The Scandinavian Journal of Economics, 113*(3), pp. 579-602.
31. PricewaterhouseCoopers, & ZEW. (2005). International Taxation of Expatriates. Survey of 20 Tax and Social Security Regimes and Analysis of Effective Tax Burdens on International Assignments. Fachverlag Moderne Wirtschaft.
32. Quinn, D. (1997). The Correlates of Change in International Financial Regulation. *American Political Science Review, 91*(3), pp. 531-551.

33. Riedl, A., & Rocha-Akis, S. (2012). How elastic are national corporate income tax bases in OECD countries? The role of domestic and foreign tax rates. *45(2)*, pp. 632-671.
34. Slemrod, J. (2004). Are corporate tax rates, or countries, converging? *Journal of Public Economics*, *88(6)*, pp. 1169-1186.
35. Smith, S. (1997). The Definitive Regime for VAT. *Institute for Fiscal Studies*.
36. Sørensen, P. B. (2007). Can Capital Income Taxes Survive? And Should They? *CESifo Economic Studies*, *53(2)*, pp. 172-228.
37. Tosun, C. (2006). Expected nature of community participation in tourism development. *Tourism management*.
38. Walicka, M. (2012). Podatkowe uwarunkowania konkurencyjności małych przedsiębiorstw. *Prace Naukowe Uniwersytetu Ekonomicznego we Wrocławiu*.
39. Weichenrieder, A. J. (2005). (Why) Do we need Corporate Taxation? *CESifo Working Paper Series*, 1495.
40. Winner, H. (2005). Has Tax Competition Emerged in OECD Countries? Evidence from Panel Data. *International Tax and Public Finance*, *12(5)*, pp. 667-687.
41. Zodrow, G. R. (2006). Capital Mobility and Source-Based Taxation of Capital Income in Small Open Economies. *International Tax and Public Finance*, *13(2)*, pp. 269-294.

# SHADOW CASHING SCHEMES IN THE CONTEXT OF JUDICIAL EXPERTISE

**Evgenia V. Baturina**

*Saint-Petersburg University of the  
Ministry of Internal Affairs of Russian Federation, Russia  
ibm600x@mail.ru*

**Aleksandr N. Litvinenko**

*Saint-Petersburg University of the  
Ministry of Internal Affairs of Russian Federation, Russia  
lanfk@mail.ru*

**Liudmila A. Guzikova**

*Peter the Great Saint-Petersburg Polytechnic University, Russia  
guzikova@mail.ru*

## ABSTRACT

*In this article the main theoretical and practical issues of expert investigation of cash flow through the banks accounts of investigated entities are discussed. The aim of the paper is to work out the algorithm of the cash flow investigation for the purpose of shadow schemes revealing. Directions for expert investigation of cash flows are identified; the requirements to automated information-analytic system are substantiated. The conclusions, suggestions and recommendations can be used in educational, law creation, law enforcement, judicial activity and judicial and expertise activities.*

**Keywords:** *economic crimes, illegal banking, shadow economy, shadow cashing schemes, cash flow investigation, financial expertise*

## 1. INTRODUCTION

According to (UN,1999) the state should establish the measures for the supervision of all money-transmission agencies and to detect or monitor the physical cross-border transportation of cash and bearer negotiable instruments in order to prevent financing of terrorist activity. Illegal banking, under the article 172 of the Criminal Code of the Russian Federation, is one of the economic crimes in Russia committed via the use of national banking system resources. Via banking (settlement) accounts controlled by the certain bogus commercial entities, the shadow cashing schemes for illegal cash receiving are realized (Korobov, 2017). Through mutual transfers, the final withdrawal of funds to the participants of shadow cashing schemes is realized to meet their illegal demands or to finance illegal activities (Chattaev, 2017). The aim of the paper is to work out the algorithms of the cash flows investigation for the purpose of shadow schemes revealing and the requirements to automated information-analytic system for support of juridical expertise of cash flows. The information base of the study is composed of the legal acts of Russian Federation, methodical documents of financial control and generalized practical experience of the authors.

## 2. BASIC PROVISIONS AND RESULTS

According to the practice of the shadow cashing investigation, as a rule, judicial accounting expertise is prescribed to define the size of illegal economic benefit (Kelm, 2017). The studies aimed to solve the following types of expert tasks have the most urgency.

## **2.1. First (typical) direction**

When investigating the most economic crimes, typical tasks are the following:

1. 'from who, what amount of money and with what kind of payment was the admission of cash made for the fixed period of time?'
2. 'to whom, what amount of money and with what payment basis was that cash transfer made for the fixed period?'

Issues posed to the expert should be concretized about the involved entities, the period of time and the appeared circumstances. The following data should be indicated: the title and the identifying features of the investigated organization (its legal form, individual number of a taxpayer, banking current account details, the title of the organization which provides loans and its individual number for a tax payment). Object of the investigation is usually an extended account statement including the cash operations on the bank account of the investigated entity that is provided for an expertise for a fixed period of time. Typical method of economic expertise is:

- Within the task 1 – investigation of the extended account statement through the information analysis of the credit data, in order to find out and to group cash flows and reasons due to which counterparties transferred money to investigated deposit.
- Within the task 2 - investigation of the extended account statement through the information analysis of the debit data in order to find out and group amount of cash flows and reasons due to which money was transferred from investigated deposit to counterparties.

For investigation of the documents, specialists also use the methods of documentary control, arithmetic calculation and grouping method with the use of standard program means. The data should be represented in the tables organized in the calendar order and should contain for each counterparty: 1) Date of the transaction; 2) number of document taken as a foundation for transaction; 3) taxpayer's bank account requisites (individual number of a taxpayer, title/ name, surname); 4) sum of money on a debit operation (expenses), in rubles; 5) sum of money on a credit operation (receipts), in rubles. In addition, the expert mandatorily makes a special table which contains information about returned payments written off the account earlier. This table is similar to the previous one and is composed with the method of information grouping and the method of information comparing according to the disclosed facts of returned payments: 1) bank account requisites are wrong, 2) bank account was closed, 3) the sum was transferred by mistake. Thus, information received during the investigation should be generalized and a conclusion on the expertise issue should be formulated on the base of the data grouped for each counterparty and generalized with use of payment bases.

## **2.2. Second direction (illegal banking)**

During the investigation of economic crimes, based on article 172 of the criminal code of the Russian Federation on the fact of illegal financial activity, the formulation of tasks and expertise methods are different though extended account statement of credit organizations reflecting the cash flows between bank account of investigated firm are still an object of the investigation. Two directions of investigation may be distinguished based on practice of Expertize-Criminalistics Centre of Saint-Petersburg and Leningrad region in 2008-2018 taking into account that pointing out the amount of remuneration of alleged defendants in criminal cases in the form of a certain percentage, is the prerogative of the person who appoints the judicial economic (accounting) expertise:



1. what is 4.5% of the total sum entered into the bank account of the investigated organization during the period equal to?
2. what is 4.5% of the total sum written from the bank account of the investigated organization during the period equal to?

It is necessary to note, that before judicial economic (accountancy) expertise is assigned, during the preliminary investigation the facts of illegal money transfer and cashing service of individuals and companies must be fixed. The essence of provable crime is that through cashing out money from fake firms under control of the crime group members, they receive money regularly by taking the percent from the total amount of cashed out money, without the government control and registration as a credit organization and without being licensed as a credit organization. The list of fake firms under control as well as the requisites of their used bank accounts should be enumerated in the case of pointing out the judicial economic expertise. Expanded statements of credit organizations on cash flows between the all investigated bank accounts must be represented for the expertise as an object of investigation. In this case, the solution of expertise task 1 consists of two steps: 1) investigation of expanded statements for certain period in order to receive information about the total amount of cash entered into the account excluding returned payments, inside and mutual cash transactions; 2) calculation 4.5 % of the total sum, entered into the bank account excluding returned payments from correspondent-banks, inside and mutual transfers. It's necessary to mention that regardless of the method to determine the income received by the investigated entity from the illegal banking transactions, the total sum must be reduced by: 1) sum of inside and mutual transfers between bank accounts which are under control of the investigated entity; 2) sum of returned payments; 3) sum of transfers that are not relevant to illegal operations; 4) sum of other operations. To mutual transactions should be attributed cash receipts into the bank account of investigated entity from other bank accounts controlled by this entity. To inside operations with returned cash should be attributed the cash inflows to every investigated bank account as the return of the sum spent within the investigated period. But inflows that were returned from other bank accounts can't be attributed to the sums of return transactions because these inflows are attributed to mutual or inside operations.

### **2.3. The third (perspective) direction**

Judicial accounting investigation for determining sources of inflows and distribution of outflows is a perspective direction of expert research (Baturina & Litvinenko, 2018). The particular method used in the expert activity includes 2 stages: 1) within the investigation period, should be determined a) date, sum, information of a payer, reason of receipts (payment assignment); b) date, sum of money, information of a payee, reasons of writing off, from the date of the first receipt (payment assignment) till the depersonalization of a transfer in completed debit transactions; 2) the minimum amounts of inflow contained in expenditure should be determined step by step according to consistent dates. In expert practice, the axiom of irrefutable judgment about the depersonalization of money held in the bank account of the entity in a particular date is applied. In other words, it is impossible to find out what certain inflows form the source of the certain outflow using expert methods (Chattaev, 2017; Schneider & Caruso, 2011). Today, the real opportunity to evaluate the picture of the economic crime of the shadow scheme participants is the use of the method described above through the use of functional tools of software. In the practical implementation of the method under consideration, it is possible to obtain the distribution structure of the cash flow. In this regard, when investigating economic crimes, the described method is one of the sought after ones, since as a result of its use, law enforcement agencies can see the structural scheme of cash flows among participants (Ryder, 2015). In this case, the assessment of the illegal economic benefits, and

hence the material damage caused by the investigated economic crime is the most objective and complete (Shilovich, 2018). Unfortunately, today the described methodology of expertise is applied, mainly, manually (using the basic software), which narrows the expert's capabilities to analyze complex and intricate criminal shadow cashing schemes due to a subjective factor (limited human capabilities when processing large volumes of data). At present, informational and analytical systems for monitoring the shadow economy are being developed, the main idea of which is the following hypothesis: based on open data of monitoring economic crime, it is possible to track shadow money flow in the regional economy and create a base of encrypted information about the facts of shadow activity (Baturina, 2018). Shadow cash flow in the banking sector is considered from the standpoints of the banking system and of the subject of an economic crime. It is proposed to use the shadow cash flow in the banking sector as one of the main economic indicators characterizing the economic security of the country and the level of economy's criminalization (Baturina & Lobanov, 2018). The methodological basis of the proposed information-analytical system is the expert technique discussed above. In the near future, with the successful development of all technical issues and administrative tools of the developed information-analytical system, it is planned to present the corresponding software product. This allows getting a picture of the distribution of cash flow, with the necessary identification features in an automated mode, on the basis of the initial data from bank statements: information on the taxpayer, date and time, sum, bank account, bank transaction.

### 3. CONCLUSION

Three areas of expert activities related to the identification of cash withdrawal schemes include 1) identifying participants in payment transactions; 2) determining the amounts of write-offs and receipts and their compliance with the requirements of the legislation; 3) determination of the sources of formation and (or) directions of expenditure of transferred funds in the analysis of cash flow in a bank (settlement) account. To estimate the shadow money flow in the economy on the basis of open data of monitoring on economic crime, it is necessary to create specialized information and analytical system and database on the facts of shadow activity. It is suggested to use the metrics of the shadow cashing as indicators characterizing economic security of the country.

### LITERATURE:

1. Baturina, E.V. (2018). Development of an open information-analytical system for monitoring the shadow economy. In A. V. Babkin (Ed.) *Digital economy and industry 4.0: new challenges: proceedings of the scientific-practical conference with international participation* (471-478). St. Petersburg, Russia: Publishing house of Polytechnic Institute. [In Russian]
2. Baturina, E.V. & Litvinenko, A.N. (2018). Monitoring of shadow cash flows by computer modeling tools. *Economics of the region*, 14 (1), 326-338. [In Russian]
3. Baturina, E.V. & Lobanov, O.S. (2018). Monitoring of economic crime in the concept of assessment of the state of economic security of Russia. *Corporate governance and innovative development of the economy of the North: Bulletin of the research center of corporate law, management and venture investment of Syktyvkar state University*, 2. 119-128. [In Russian]
4. Chattaev, A.R. (2017). Terrorism as an instrument of the corruption shadow schemes. *Eurasian law journal*, 7 (110), 252-253. [In Russian]
5. Kelm, D.D. (2017). Shadow schemes in the Russian economy. *Postulate*, 5-1 (19), 99-103. [In Russian]

6. Korobov, A.A. (2017). On some shadow schemes of financing of terrorism and extremism. *Scientific Bulletin of Oryol Law institute of the Ministry of Internal Affairs of the Russian Federation of a name of V. V. Lukyanov*, 4 (73), 53-56. [In Russian]
7. Ryder, N. (2015). *The Financial War on Terrorism: A Review of Counter-Terrorist Financing Strategies since 2001*. London, UK: Routledge.
8. Schneider, F. & Caruso, P. (2011). *The (Hidden) Financial Flows of Terrorist and Transnational Crime Organizations: A Literature Review and Some Preliminary Empirical Results*. Economics of Security Working Paper Series 52, DIW Berlin, German Institute for Economic Research.
9. Shilovich, O.B. (2018). The expansion of the shadow sector of the economy as a threat to economic security. *Scientific work of the Kuban state technological University*, 6, 500-508. [In Russian]
10. UN, (1999). International Convention for the Suppression of the Financing of Terrorism. <http://www.un.org/law/cod/finterr> (Access date: 12.11.2018).

## **CORRELATION BETWEEN MOBILE GAMES MARKET AND THE DEVELOPMENT OF VIDEO GAME MARKET IN CHINA**

**Josko Lozic**

*Zagreb University of Applied Sciences, Croatia  
jlozic@tvz.hr*

**Marin Milkovic**

*University North, Croatia  
mmilkovic@unin.hr*

**Ines Lozic**

*Dignus savjetovanje, Croatia  
ineslozic1@gmail.com*

### **ABSTRACT**

*The aim of this paper is to point to the link between the development of mobile video game markets and the development of video game markets in China. The mobile video game industry, as a "new" media industry, already has higher revenue on the Asian and Pacific market than the traditional media markets in the US and Europe. Mobile video games designed for smart phones and handhelds have taken the lead in earnings over the long range of video games. At the same time, the video game market in China has taken the lead in earning revenue on the global video game market. The rapid development of mobile gaming markets in China points to a change in the social paradigm and the development of post-industrial society. The growth of video game markets in Asia and the Pacific and the domination of mobile games clearly points to the trends of developing video game industry in the future.*

**Keywords:** *global video games market, mobile games market, „new media industry”, post-industrial society*

### **1. INTRODUCTION**

The video game industry is a new category of media industry resulting from digitalisation and convergence of production systems. The development of video games begins in the middle of last century within the old media industry, but its full development starts with the development of the Internet infrastructure. The first video games were programmed for consoles and reproduction on television screens, and only later they expanded to personal computers. The new millennium will bring radical changes to the video game market and unprecedented growth of smart phone and handheld games. Juul (2005: 36) proposes that a definition of a game consists of the following six features: 1) Rules: Games are rule-based; 2) Variable, quantifiable outcome: Games have variable, quantifiable outcomes; 3) Valorisation of outcome: The different potential outcomes of the game are assigned different values, some positive and some negative; 4) Player effort: The player exerts effort in order to influence the outcome; 5) Player attached outcome: The player is emotionally attached to the outcome of the game in the sense that a player will be [a] winner and “happy” in [the] case of a positive outcome, but a loser and “unhappy” in [the] case of a negative outcome; and 6) Negotiable consequences: The same game [set of rules] can be played with or without real-life consequences. Video games, as an evolution of the analogical game, as a digitalization of the game, have become the most relevant contemporary emergent cultural form, in terms of consumption and business volume (Escribano 2012: 201). Games are certainly infused with culture. National culture, nerd culture, geek culture, gamer culture, anime culture and numerous others instil all aspects of game and game development studio alike. Cultural aspects infuse the very design of a game.

Games become a referent point for conversations about new games. This has been conceptualized as a three-part “circuit of interactivity,” by which culture, technology and marketing interact (Kline et.al. 2005: 30). Video games are also part of a sup cultural environment. In order to explain this video game phenomenon, three fundamental factors need to be put in the context of this: industry, medium and consumers (Dymek 2012: 49). Video games occupy a (pop) cultural niche competing most directly with the movie and music industries for the consumer’s time and money[...] (although the so-called serious games space is starting to make its mark more clearly (Egenfeldt-Nielsen et.al 2016: 16). Video games is a specific kind of digital entertainment in which the gamer interacts with a digital interface and is faced with challenges of various kinds, depending on the plot of the game (Zackarsson, Wilson 2012: 5). Although video games are software, they are more than software, and too often they and their producers remain lumped into the same categories as software developers. Assumptions are made about what compromises a game and its production process, which continues to hold the video game industry and the art of game production back from its full potential (O’Donnell 2012: 30). The video games software industry appears to be one of the most innovative labs for the coming digital economy: it is developing and experimenting new digital services (online, offline and mobile) that manage to reach a growing share of the population, across all demographics (De Prato et.al 2014). The post-industrial society has directly affected the radical changes within the video game industry. The appearance of smart phones and handhelds set the foundation for the growth of mobile games for "small screens". Revenue on mobile devices may well overtake revenue from consoles, and the big publishers will want to find ways to make their brands work on phones. But all of this is only going to be additive: more people are playing games than ever before, and the pie is growing (Thier 2015). Those days, a mobile game is typically one of three things (Manning, Buttfield-Addison 2017: 4): a) a simple game, with carefully chosen interactions, graphics, and controlled complexity, because the game design was best supported by these facets; b) a much more complex affair, available for anything ranging from specialized mobile game consoles to smartphones; and c) a mobile port of a game that debuted on a console or PC. In an era where Angry Birds is a household name, mobile gaming becomes more than a pastime activity. It’s a serious 21 st century industry that spans markets, continents and cultures (Alegre 2018). Feijoo points out that tablet development has enabled even greater revenue growth from mobile games and skimmed revenue from smart phone games. Tablets, a new segment started in April 2010 with the launch of Apple’s iPad, are worth considering separately as providers of a different game play experience from that of a smartphone. With its wider, full-colour touch screen display and processing power, tablets deliver graphics on par with traditional console gaming platforms, adding motion-sensitive controls and mobile/wireless broadband connectivity (Feijoo 2012: 83). Indeed, for much of the world, mobile devices have essentially become gaming platforms [...] which also happen to make telephone calls or enable video watching. While no one doubts we will continue to use mobile devices for things other than games, it’s clear that gaming has become, and will remain, in the top tier for the three key mobile usage behaviours (Chou 2013).

## **2. GLOBAL VIDEO GAMES MARKET**

According to data published by the American-based Entertainment Software Association, the US digital games market was worth US \$7.3 billion dollars in 2004. Similar figures suggest that the value of digital games for Europe was 5.6 billion Euros (Rutter, Bryce 2006: 4). De Prato et al. (2012: 223) point out, referring to the PWC research (2009, 2011), that in 2009 the global video game market was estimated at US \$52 billion. In the period 2004 to 2015, the global video game market is expected to grow from less than US \$30 billion to over US \$80 billion. In 2008, Apple made its iPhone available to software developers, and in the same year Google’s Android platform became available.

Over the years, iOS and Android have become extremely capable platforms, and mobile games are the most popular video games in the world (Manning, Buttfeld-Addison 2017: 4). The future of gaming isn't mobile any more than the future of gaming is console or PC: the future of gaming is gaming (Thier 2015). Thier points out that the passion for playing is more significant than the platform he is playing. The ratings company Nielsen reports the number of people playing online games increased by 94 percent between 2010 and 2011 – the biggest jump in any mobile-related activity (including watching videos or listening to music). And investment banking firm Jefferies shared that in 2012, the installed base for iPhones (450 million) far exceeded that of consoles (240 million); but perhaps more interestingly, consoles grew by only 20 million from 2011 compared to the double growth in mobile (and that didn't even include tablets) (Chou 2013).

*Table 1: Global video games market (\$ bill.)*

	2013	2014	2015	2016	2017	2018e
<i>Mobile</i>	17,6	21,7	30,0	36,9	46,1	70,3
<i>Console</i>	27,9	27,0	27,8	30,8	33,5	34,6
<i>PC</i>	30,0	32,8	33,7	31,9	29,4	32,9
<i>Sum</i>	75,5	81,5	91,5	99,6	109,0	137,8

*Source: Newzoo.com (own illustration)*

The results of the survey of realized revenues in the global video game market are presented in Table 1. The results of the research are referenced for a period of five years and include an estimate of income for 2018 years. Total revenues rose from \$ 75.5 billion in 2013 to \$ 109 billion in 2017. In 2018 global revenue is expected to be \$ 137.8 billion globally. Global video industry revenue has grown steadily, but they differed according to video industry categories. Regarding the future development of the video game market, it is expected it will continue to grow. However, there are some differences in the dynamics of individual segments. In particular, whereas the online and wireless product segments will grow and, as a result, increase their overall importance, the sales value of PC-based video games will decline (De Prato et.al 2012: 223). The predictions presented by De Prato et.al. have been fully realized and can be confirmed by the research results shown in Table 1. The comparative results of the growth of individual video game industry segments are shown in Table 2. The largest total revenue growth in the video game industry was achieved in 2015 and amounted to 12.3%. The scientists expect an increase in revenues in the estimated period of 2018, from 26.4%. In the period with the largest total revenue growth, mobile games accounted for the highest revenue growth of 28.2% compared to the previous period. By comparing the rise in total revenues and revenues in mobile gaming indices, we can confirm a strong correlation.

*Table 2: Growth of the global video games market (%)*

	2014 vs. 2013	2015 vs. 2014	2016 vs. 2015	2017 vs. 2016	2018 vs. 2017	Average	2018 vs. 2013
<i>Mobile</i>	23,3%	38,2%	23,0%	24,9%	52,5%	32,4%	399,4%
<i>Console</i>	-3,2%	3,0%	10,8%	8,8%	3,3%	4,5%	124,0%
<i>PC</i>	9,3%	2,7%	-5,3%	-7,8%	11,9%	2,2%	109,7%
<i>Sum</i>	7,9%	12,3%	8,9%	9,4%	26,4%	13,0%	182,5%

*Source: own illustration*

The other two categories of industry recorded a decline in revenues in one of the analyzed periods. The console gaming industry had a drop in revenue of 3.2% in 2014, while personal computer games were down by 2016 and 2017. The average revenue growth in mobile games was 32.4%, while the average revenue growth in the category of games for PC was 2.2%. Total revenue growth in the video game industry in 2018 compared to 2013 was 182.5%. Game consoles and PCs had a revenue growth lower than the total increase. The increase in mobile revenues really doesn't affect other marketplaces. Growth will be slower for both platforms in the coming years –primarily due to popular titles like League of Legends and Fortnite continuing to be popular for the foreseeable future – but they'll be increasing nonetheless, with 1.8% growth for PC and 4.1% growth for console by 2021. One more significant insight from Newzoo's forward-looking report: A staggering 91% of the \$137.9 billion in revenues come from digital sales (Perez 2018).

## 2.1. Global mobile video games market

The expansion of mobile gaming is noteworthy also in terms of quality, as mobile games have become a site for innovative, new play and game design practices. Many of the novel innovations that mobile games have introduced benefit from the specific characteristics of the mobile media ecosystem, including the online digital distribution channels, new interface modalities, and sensor capabilities available in modern mobile devices (Mayra 2015). Mobile games, played on tablets and smartphones, mean that games are never further arm's length (Willson, Leaver 2016: 1). Of the approximately 7 billion humans on this planet, nearly one-third of us are mobile gamers. In 2017, video technology firm Jun Group reported that 51% of its network users played mobile games for more than 30 minutes every single day and that games were the top category across all gender and age demographics. In the U.S. alone, the penetration of gamers has jumped 13% (registration required) since 2013 (Alegre 2018). Analyzing the results of the research in Table 3, we have confirmed a strong correlation between the increase in total revenues of the global video game industry with the industry of mobile video games. Table 3 shows an increase in the share of mobile video games in the total industry. The share of mobile video games revenue in total industry revenue grew from 23.3% in 2013 to 42.3% in 2017. Analysts estimate that the share of mobile games in 2018 will be over 50% of revenue.

Table 3: Global mobile game market (%)

	2013	2014	2015	2016	2017	2018
Sum	75,5	81,5	91,5	99,6	109,0	137,8
Mobile	17,6	21,7	30,0	36,9	46,1	70,3
%	23,3%	26,6%	32,8%	37,0%	42,3%	51,0%

Source: Newzoo.com (own illustration)

Table 4 shows the results of research on increasing the share of mobile game revenue. The year-on-year growth of mobile gaming revenue was higher than in the previous year, when the largest increase in mobile gaming revenue was achieved. 2015 saw revenue growth of 38.2 percent, which was 23.1 percent more than the previous year's increase. Analysts expect revenue growth in the last period of 32.4%, and market share of mobile gaming industry in the total industry by 51%, which is the absolute best result in the industry's gaming history for all video game categories.

*Table 4: Comparative increase in share (%)*

	2014 vs. 2013	2015 vs. 2014	2016 vs. 2015	2017 vs. 2015	2018 vs. 2017	Average	2018 vs. 2013
Sum	7,9%	12,3%	8,9%	9,4%	26,4%	13,0%	182,5%
Mobile	23,3%	38,2%	23,0%	24,9%	52,5%	32,4%	399,4%
% Mobile	14,2%	23,1%	13,0%	14,2%	20,6%	17,0%	

*Source: Newzoo.com (own illustration)*

The estimates of the distribution of revenue in video gaming industry are shown in Table 5. In 2018, revenue from mobile games is expected to be greater than 50% of total revenue. The revenue trend within the industry also points to the recovery of the console gaming revenue share relative to PC gaming revenue. 2018 is expected to increase console gaming revenue from PC gaming revenue. Analysts estimate that revenue growth from mobile games will have an increasing share within the industry. At the same time, the console gaming revenue share will grow, while the share of PC gaming revenue will fall.

*Table 5: 2012 - 2021 Global games market*

Games	2012	2013	2014	2015	2016	2017	<b>2018</b>	2019	2020	2021
<b>Mobile</b>	<b>18%</b>	<b>23%</b>	<b>29%</b>	<b>34%</b>	<b>40%</b>	<b>46%</b>	<b>51%</b>	<b>54%</b>	<b>57%</b>	<b>59%</b>
PC	37%	38%	36%	34%	30%	27%	<b>24%</b>	22%	21%	19%
Console	45%	39%	35%	32%	30%	27%	<b>25%</b>	24%	19%	22%

*Source: Newzoo.com (own illustration)*

Exponential growth in mobile revenue was also directly influenced by increased tablet usage. The tablet has become a kind of modern console but has more technological capabilities than a console and serves as a tool to work in everyday work. Even yet in 2013 Chou already detects 2013 and emphasizes the importance of the development of smartphones and tablets for a complete change of user behaviour. Chou had point that 67 percent of all time spent on tablets is spent playing games. That's striking, especially when compared with engagement in social networking: just 10 percent of total time spent (partly due to shorter sessions). Even more tellingly, time spent playing games has overtaken the total time spent watching videos, listening to music, and reading magazines or books! (Chou 2013).

## **2.2. Geography distribution of global video games market**

Video game industry revenue is growing in all the markets analyzed, just like Thier points at 2015. This is far from a zero sum game. Gaming has been exploding in the past decade or so (really, the past three decades), and it's been doing so through a wide range of platforms (Thier 2015). The most common gamer nowadays is not a teenage boy. Sixty-two percent of mobile gamers in the United States (registration required) are women between the ages of 35 and 44, and almost a quarter of all video game players in the United States are 50 or older (Alegre 2018). Half of the entire U.S. population plays mobile games. And yet, recent research has shown that only 10% of people who play mobile games regularly consider themselves "gamers" (Wadsworth 2016).

*Table following on the next page*



Table 6: Global video games market by the regions (bill. \$)

	2013	2014	2015	2016	2017	2018
North America	21,9	22,2	23,8	25,4	27,0	32,7
South America	2,9	3,3	4,0	4,1	4,4	5,0
Europa, Africa, M. East	18,7	19,1	20,5	23,5	26,2	28,7
Asia	31,9	36,8	43,1	46,6	51,2	71,4
Sum	<b>75,4</b>	<b>81,4</b>	<b>91,4</b>	<b>99,6</b>	<b>108,8</b>	<b>137,8</b>
USA	n/a	n/a	<b>22,0</b>	23,5	25,1	30,4
China	n/a	n/a	<b>22,2</b>	24,4	27,5	37,9

Source: Newzoo.com (own illustration)

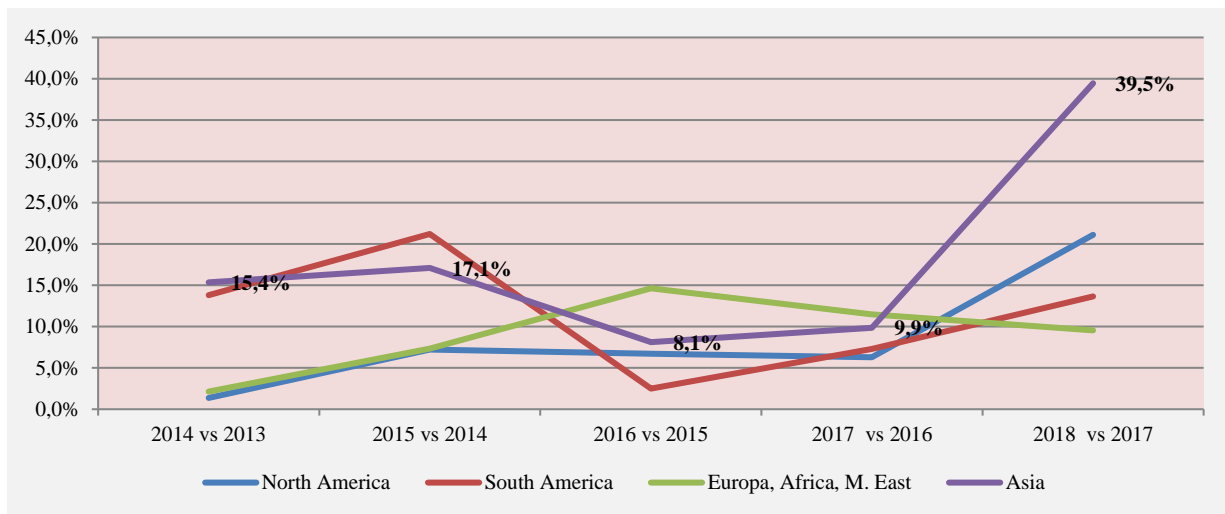

Figure 1: Growth rates of video games by geographic areas

Source: Newzoo.com (own illustration)

The US market is the largest media market and has been the largest video game market for a long time. With the development of the Asian market, the US market falls to the second place according to the revenue generated from the video game. Already in the first analyzed period, Asia has higher revenues from North America, and analysts expect that in 2018 they will earn twice as much revenue. Video game markets in Europe and South America recorded slight growth, but growth rates fell year after year. The market is approaching saturation points. The results of the research are presented in Table 6. Figure 1 shows the growth rates of the global video industry by geographical region. The South American market shows growth oscillations, which is a clear indicator of approaching the market saturation point. Similar trend is also in the North American market where analysts expect revenue growth in 2018. The European market has experienced a fall in growth rates and it is obvious that the market is already saturated. Asia's market is on a steady growth, and analysts expect a major growth in 2018. The level of revenue in the US and China market have been equals to 2015, but within the industry there is a change in revenue distribution. In the same year, mobile gaming revenue for the first time generated higher revenue from console games, and in the coming year they came in first place to earnings. In 2015, China for the first time achieved higher revenue in video game industry than the United States. That trend will continue and the gap will increase. The video game market in the USA is stagnating slowly as the market in China is growing steadily. 2016 shows a strong correlation between take over the leader position of mobile gaming in the video game industry with the takeover of the leader site on the global video industry map.

### 3. DISCUSSION

The results of the research have shown two groundbreaking trends that have taken place within the video game industry in the last few years. We can define them with the following characteristics:

- In the video game industry, redistribution of revenue occurred and the mobile games take over leadership in revenues and
- China has taken over the dominance of the global video game industry according to revenue earned.

The mobile video game industry has taken the lead in the industry of video game revenue. The diversity of games in app stores has multiplied exponentially in recent years, offering players a cornucopia of genres, including simple, hypercasual titles that require little training or commitment (Alegre 2018). Video games for consoles and PCs, belonging to the "old" media industries, have given way to the "new" media industry. But, mobile games will never kill game consoles. There are several reasons for that claim. The bottom line: consoles (or gaming PCs) are still necessary for high end games, and mobile only took a small share of that. There are some people who can't afford both, and some who have given up high end games for more casual ones, but for the most part people who want to play the Battlefields and FIFAs of the world aren't able to replace that with their phones (Quora 2018). The rise in global mobile video game revenue is directly linked to the rapid rise in video game content in China. The correlation between these two parameters shows us the dramatic changes that the Chinese media industry has undergone. On the one hand, China builds a very strong industrial society, and on the other hand we have clear indications of changes in Chinese society and very obvious characteristics of the influence of postmodern and post-industrial society. China quickly accepted mobile gaming and took the lead in earnings. All this undoubtedly indicates that the old media industry is losing ground in China. Postmodern and post-industrial society is slowly beginning to dictate and change in China. The US currently has around 139 million mobile gamers. The numbers vary, but according to Cao, China now has approximately 183 million gamers, and it is believed that 71% of the online population of China is an (occasional) online gamers, making it the largest online game market in the world (Koetse 2016). The report this week from investment firm Atomico notes the market value for games in China is \$24.4bn, accounting for 25% of the global market. It also observes there are 600m gamers in China - twice the population of the US - and with the well-documented dominance of smartphones in the region, it appears to be a prime opportunity for mobile developers (Batchelor 2017). The number of female gamers active in the Chinese market grew 6 per cent year-on-year to reach 264 million in 2017, accounting for 45 per cent of the total in the country, according to a report by industry database Gamma Data Corp. The company predicted that the number will grow steadily in the coming months, reaching 281 million this year (Shijai 2018). The rising number of mobile devices worldwide will result in an estimated 4.78 billion mobile users worldwide by 2020 (registration required). The equation is simple: More games plus more devices to play on equals more mobile gamers. Users already spend 87% of their mobile device time in an app, and it's likely that app is a game (Alegre 2018). Additionally, the number of female mobile game users is equal to the number of men. The rise in the number of mobile phones in China and the equal participation of all genders and age groups in the mobile gaming industry confirms the postmodern influence in China, while guaranteeing the continuation of the Chinese domination in the video game industry.

### 4. CONCLUSION

The video game industry appeared at the end of the last century and became part of the "old" media industry. Video games developed as a physical product or console that used to play on a

screen. In most cases it was a home television. With the development of television screens and the development of personal computers, a special segment of video games for personal computers has developed. Developing the industry of "small" screens, smart phones and tablets, have become the foundation for developing mobile games. The "old" media industry was built at the time of the modern era and followed all the characteristics of society from the end of the 20th century. He followed the principles of mass media and industrial society. The development of the Internet, digitization of production processes and in particular the appearance of a smartphone, have become the foundation for the development of a new category of video game industry or mobile gaming segments. Only eight years after the appearance of the first iPhone mobile gaming industry, it achieves the highest revenue into global game industry. Mobile video game industry has all the characteristics of a "new" media industry. Mobile video games mean users' ongoing interaction, use of internet connectivity, can play against the platform, but also against other players, group vs. groups, and so on. The game model is adapted to the post-industrial age in which it is possible to participate in the construction of the game. A sharp increase in mobile gaming revenue in China opens the door to new research of the phenomenon of such an expanding growth in revenue, but also the same changes that the Chinese society has been experiencing over the past decade.

#### LITERATURE:

1. Alegre, M. (2018). "Why Mobile Games Are More Important To Your Brand Than You Thought", *Forbes*. <https://www.forbes.com/sites/forbestechcouncil/2018/09/05/why-mobile-games-are-more-important-to-your-brand-than-you-thought/#45b7f4651522>;
2. Batchelor, J. (2017) "Realising your mobile game in China is an absolute necessity". *Gameindustry.biz*. <https://www.gamesindustry.biz/articles/2017-06-05-releasing-your-mobile-game-in-china-is-an-absolute-necessity>; [08.11.2018.]
3. Chou, K. (2013). „Mobile Kills The Console But Advances The Gaming Industry“. *Wired Magazin*. <https://www.wired.com/2013/01/how-mobile-kills-the-console-but-advances-the-gaming-industry/>; [09.11.2018.]
4. De Prato, G.; Feijoo, C.; Simon, J.P. (2014) *The Road to E-Services: Online and Mobile Games as Enablers*. (eds), Beak, Y. et al. Trends and Application of Serious Gaming and Social Media, Gaming Media and Social Effects. Springer Science+Business Media Singapore
5. De Prato, G.; Lindmark, S.; Simon, J.P. (2012). „The evolving European Video Game Software Ecosystem“. (eds). Zackarsson, P.; Wilson, L. T. *The Video Game Industry: Formation, Present State and Future*. Taylor & Francis.
6. Dymek, M. (2012). „Video Games: A subcultural Industry“, (eds) Zackarsson, P.; Wilson, L. T. *The Video Game Industry: Formation, Present State and Future*. Taylor & Francis.
7. Egenfeldt-Nielsen, S.; Smith, J.H.; Tosca, S.P. (2016) *Understanding Video Games: The essential Introduction, Third Edition*, Routledge, Taylor & Francis Group,
8. Escribano, F. (2012) „Gamification as the Post-Modern Phalanstere: Is the Gamification Playing with Gamification?“, (eds.) Zackarsson, P.; Wilson, L. T.(eds) (2012) *The Video Game Industry: Formation, Present State and Future*, Taylor & Francis,
9. Feijoo, C. (2012) „An Exploration of the Mobile Gaming Ecosystem from Developer's Perspective“, (eds) Zackarsson, P.; Wilson, L. T., *The Video Game Industry: Formation, Present State and Future*, Taylor & Francis,
10. Juul, J. (2005) *Half Real: Video Games between Real Rules and Fictional Worlds*, Cambridge, MA: The MIT Press,
11. Kline, S.; Dyer-Witheford, N.; de Peuter, G. (2003) *Digital Play: The Interaction of Technology, Culture, and Marketing*, Quebec: McGill-Queen's University Press,

12. Koetse, M. (2016). "Game Time: 5 Must-Knows About China's Mobile Gaming Market". *China Digital*. <https://www.whatsonweibo.com/game-time-5-must-knows-chinas-mobile-gaming-market/>; [08.11.2018.]
13. Manning, J.; Buttfield-Addison, P. (2017) *Mobile Game Development with Unity: Build Once, Deploy Anywhere*, O'Reilly,
14. Mayra, F. (2015) "Mobile Games". (eds). Mansell, R.; Hwa, P. *The International Encyclopaedia of Digital Communication and Society*, First Edition. John Wiley & Sons, Inc.
15. Newzoo - <https://newzoo.com/> - [05. 11. 2018.]
16. O'Donnell, C. (2012) „This is Not a Software Industry“, Zackarsson, P.; Wilson, L. T. (eds), *The Video Game Industry: Formation, Present State and Future*, Taylor & Francis,
17. Perez, M. (2018). „Report: For The First Time, Mobile Will Make Up Half OF All Gameing Revenue“. *Forbes*. <https://www.forbes.com/sites/mattperez/2018/04/30/report-for-the-first-time-mobile-will-make-up-half-of-all-gaming-revenue/#492a9447586a>; [08.11.2018.]
18. Quora Contributor (2018) "Every Thought Mobile Would Kill Game Consoles. Here's Why That Didn't Happen". *Forbes*. <https://www.forbes.com/sites/quora/2018/02/23/everyone-thought-mobile-would-kill-game-consoles-heres-why-that-didnt-happen/#ce257534f535>; [15.11.2018.]
19. Rutter, J.; Bryce, J. (2006) *Understanding Digital Games*, Sage Publications,
20. Shijai, O. (2018). "Female video gamers splash the cash online". *The Telegraph News, World News*. <https://www.telegraph.co.uk/news/world/china-watch/technology/female-gamers-in-china/>; [11.11.2018.]
21. Thier, D. (2015). „Mobile Isn't The Future Of Gaming (And Consoles Aren't Either)“. *Forbes*. <https://www.forbes.com/sites/davidthier/2015/05/15/mobile-isnt-the-future-of-gaming-and-neither-is-console/#125f5d60bd1a> [11.11.2018.]
22. Wadsworth, S. (2016). „ Mobile Gaming Has Gone Mainstream: Here's How Brands Can Take Advantage“. *Forbes*. <https://www.forbes.com/sites/forbesagencycouncil/2016/11/02/mobile-gaming-has-gone-mainstream-heres-how-brands-can-take-advantage/#2f8114943cae>; [08.11.2018.]
23. Willson, M.; Leaver, T. (2016). "Casual Games and Mobile Devices: The Shifting Contexts of Gamers and Gaming". (eds.) Willson, M.; Leaver, T. *Social, Casual and Mobile Games: The Changing Gaming Landscape*. Bloomsbury Academic
24. Zackarsson, P.; Wilson, L. T.(eds). (2012). *The Video Game Industry: Formation, Present State and Future*. Taylor & Francis.

## THE PRINCIPLE AND THE DEVELOPMENT OF VAT GAP IN SELECTED EU COUNTRIES

**Jaroslav Korecko**

*University of Prešov in Prešov, Faculty of Management, Slovakia*  
jaroslav.korecko@unipo.sk

**Alzbeta Suhanyiova**

*University of Prešov in Prešov, Faculty of Management, Slovakia*  
alzbeta.suhanyiova@unipo.sk

### **ABSTRACT**

*European tax studies estimate 1 trillion € in public money is lost due to tax fraud and tax avoidance every year in the EU. The current tax gap in Europe represents an alarming loss of public revenue. It is also a threat to the proper functioning of the Single Market and a dent to the efficiency and fairness of tax systems within the EU. Lot of analyzes have confirmed that the status and the development of the VAT Gap is influenced by several economic variables as well as by policy actions. The article deals with examining VAT Gap in selected EU countries. The analysis is based on theoretical background about tax gap. Besides the dimension of VAT Gap in selected Member States we have analyzed other significant indicators, which affect the VAT Gap too. Further we have focused on the situation within the European Union and compared the Member States among themselves. During the comparing we observed some similarity between countries, so we used the cluster analysis to verify this assumption of similarity. Main objective of the article is to explore several indicators affecting the VAT Gap and compare them.*

**Keywords:** Cluster analysis, European Union, VAT Gap

### **1. INTRODUCTION**

According to the European Commission (2018) Member States in the European Union are losing billions of euros in value-added tax (VAT) revenues because of tax fraud and insufficient tax collection. The VAT Gap is the difference between expected and collected VAT revenues. The VAT Gap provides an estimate of revenue loss due to tax fraud, tax evasion and tax avoidance, but also due to bankruptcies, financial insolvencies or miscalculations. The variations of VAT Gap estimations between the Member States reflect the existing differences in terms of tax compliance, fraud, avoidance, bankruptcies, insolvencies and tax administration. It offers an indication about the performance of national tax administrations but should not be looked at in an isolated way. A variety of circumstances could have an impact on the size of the VAT Gap such as economic developments. The current tax gap in Europe represents not only an alarming loss of public revenue but also a danger for the safeguarding of the EU social model based on quality public services available to all citizens. It is a threat to the proper functioning of the Single Market and a dent to the efficiency and fairness of tax systems within the EU. The loss of revenues continues to increase the deficit and debt levels in the Member States right at the most crucial time of fighting the crisis.

### **2. THEORETICAL BACKGROUND**

In common the Tax Gap is the difference between total amount of taxes owed to the government contrasted with the amount they receive. Generally, a tax gap is caused by taxpayers overstating deductions and understating their income, so they can pay fewer taxes; but late paying taxpayers also cause the tax gap. VAT is a consumption tax, charged on most goods and services traded for use or consumption in the EU.

It is levied on the "value added" to the product at each stage of production and distribution. The "value added" means the difference between the cost of inputs into the product / service and the price at which it is sold to the consumer. VAT is charged when VAT-registered (taxable) businesses sell to other businesses (B-2-B) or to the final consumer (B-2-C) (European Commission–b). The VAT Gap is defined as the difference between the expected VAT receipts if all the VAT which is due is collected and the actual VAT collected by Member States. It is calculated, in this study, based on national consumption figures in government accounts. The calculations also take on board the specificities of each national tax system i.e. the various reduced rates, exemptions etc. when assessing the expected/theoretical VAT receipts (European Commission–a). There are two different measurements of the tax gap. The first measurement is the "gross tax gap," or the difference between tax liability paid and the true tax liability. The "net tax gap" is the gross tax gap less payments of the year's tax liability that are collected either via voluntary late payments or via a tax agency's enforcement efforts. Policymakers are often more concerned with the net tax gap than with the gross tax gap because the net tax gap is considered a better indication of the effectiveness of tax compliance efforts (Alm, Borders, 2014). Warren and McManus focus on the importance of the „tax gap“. They point out that tax gap is crucial to governments and to the development of appropriate government policy, because estimating tax gap would enable (Warren, McManus, 2007):

- verification of the level of risk assessed in relation to risk areas identified;
- a comprehensive analysis of all areas of compliance and non-compliance;
- identification of areas of risk not previously identified or ranked;
- monitoring of the quantification of risk areas over a period using a comparable estimate;
- assessment of the effectiveness of attempts to reduce the non-compliance in a risk area and in aggregate;
- comparison of relative risks across all areas.

Lot of studies have confirmed that the status and the development of VAT gaps in national economies are influenced by several economic indicators as well as by policy actions. Some of the factors are shown in Figure 1. Mutual connections of factors are displayed too.

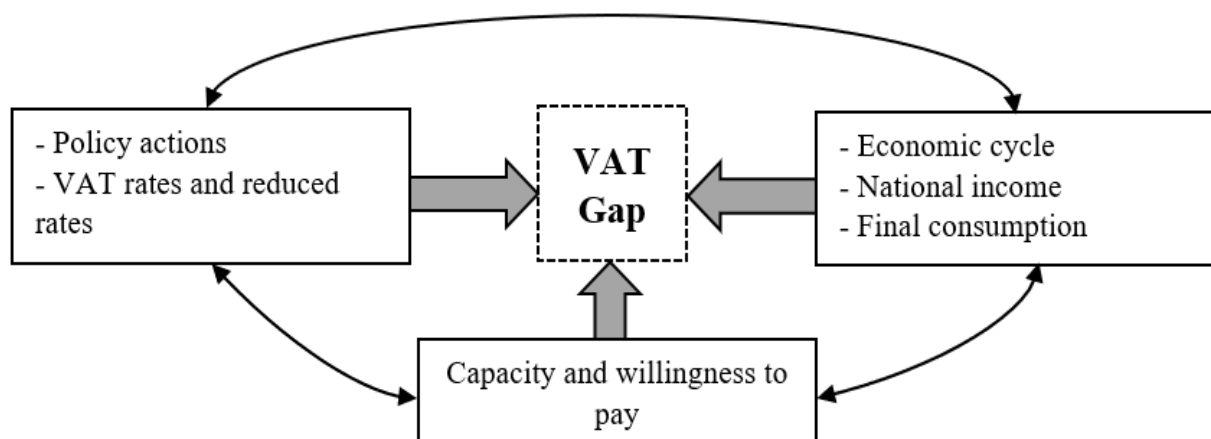

Figure 1: Influence of different factors on VAT Gap (authors)

### 3. VAT GAP IN THE EUROPEAN UNION

There are many factors describing the economic situation of a country. In the previous Figure 1, aggregated indicators are shown, which affect, respectively can affect the size of the VAT Gap. The phase of the economic cycle can be identified through GDP growth in recent years.

The following Table 1 except GDP shows the Wages and salaries and Final consumption of households in the Member States (Minimum and maximum values are highlighted in each column.). One of the fundamental characteristics of time series is the average growth coefficient ( $k'$ ) calculated in the table.

$$k' = \sqrt[t]{k_1 \cdot k_2 \cdot \dots \cdot k_{t-1}}$$

Where  $k_t$  is growth coefficient and  $t$  is the number of seasons.

Table 1: Selected national indicators influencing the VAT Gap (calculated according Eurostat)

Country	GDP - Percentage of EU-28 (2017)	GDP $k'$ (2008-2017)	Wages and salaries $k'$ (2008-2017)	Final consumption $k'$ (2008-2017)
Belgium	2,9	1,0237	1,0220	0,9984
Bulgaria	0,3	1,0344	<b>1,0673</b>	0,9934
Czech Republic	1,3	1,0195	1,0228	0,9995
Denmark	1,9	1,0199	1,0192	0,9998
Germany	<b>21,3</b>	1,0273	1,0345	0,9950
Estonia	0,2	1,0375	1,0335	0,9929
Ireland	1,9	1,0519	0,9951	<b>0,9588</b>
Greece	1,2	<b>0,9663</b>	<b>0,9615</b>	1,0065
Spain	7,6	1,0046	0,9989	1,0030
France	14,9	1,0157	1,0178	0,9981
Croatia	0,3	1,0013	0,9958	<i>confidential</i>
Italy	11,2	1,0056	1,0081	1,0031
Cyprus	<b>0,1</b>	1,0012	0,9988	1,0093
Latvia	0,2	1,0109	1,0048	1,0089
Lithuania	0,3	1,0278	1,0289	1,0002
Country	GDP - Percentage of EU-28 (2017)	GDP $k'$ (2008-2017)	Wages and salaries $k'$ (2008-2017)	Final consumption $k'$ (2008-2017)
Luxembourg	0,4	1,0423	1,0454	0,9888
Hungary	0,8	1,0149	1,0183	0,9918
Malta	<b>0,1</b>	<b>1,0685</b>	1,0626	0,9783
Netherlands	4,8	1,0154	1,0154	0,9980
Austria	2,4	1,0259	1,0303	1,0000
Poland	3,0	1,0270	1,0133	0,9944
Portugal	1,3	1,0085	1,0027	1,0026
Romania	1,2	1,0283	1,0276	0,9978
Slovenia	0,3	1,0147	1,0118	1,0047
Slovakia	0,6	1,0285	1,0419	0,9970
Finland	1,5	1,0160	1,0177	<b>1,0095</b>
Sweden	3,1	1,0343	1,0364	0,9990
United Kingdom	15,2	1,0183	1,0147	1,0011

The process of indirect tax harmonization in the EU, which includes a certain degree of tax rates harmonization, is also reflected in VAT in the Member States. In all countries, the Standard VAT rate is above 15%. Four of the Member States apply a Super-reduced VAT rate to selected goods or services. Denmark, on the other hand, applies only the Standard rate. Among Member Countries the highest standard rate is in Hungary (27 %), the lowest is applied by Luxembourg (17 %). Within the EU, Croatia had the highest collection of VAT (13 % of GDP) in 2016, the lowest was reported by Ireland (4,7 % of GDP).

Table 2: VAT rates and collection in EU-28 (European Commission, Eurostat)

Country	Standard Rate*	Reduced Rate*	Super-reduced Rate*	VAT Collection in 2016 (% GDP)
Belgium	21	6/12	-	6,8
Bulgaria	20	9	-	9,2
Czech Republic	21	10/15	-	7,4
Denmark	25	-	-	9,6
Germany	19	7	-	7,0
Estonia	20	9	-	9,4
Ireland	23	9/13,5	4,8	<b>4,7</b>
Greece	24	6/13	-	8,2
Spain	21	10	4	6,4
France	20	5,5/10	2,1	6,9
Croatia	25	5/13	-	<b>13,0</b>
Italy	22	5/10	4	6,1
Cyprus	19	5/9	-	9,2
Latvia	21	12	-	8,2
Lithuania	21	5/9	-	7,8
Luxembourg	<b>17</b>	8	3	6,5
Hungary	<b>27</b>	5/18	-	9,3
Country	Standard Rate*	Reduced Rate*	Super-reduced Rate*	VAT Collection in 2016 (% GDP)
Malta	18	5/7	-	7,3
Netherlands	21	6	-	6,9
Austria	20	10/13	-	7,7
Poland	23	5/8	-	7,0
Portugal	23	6/13	-	8,5
Romania	19	5/9	-	6,5
Slovenia	22	9,5	-	8,2
Slovakia	20	10	-	6,7
Finland	24	10/14	-	9,1
Sweden	25	6/12	-	9,2
United Kingdom	20	5	-	6,8

\* Situation at 1<sup>st</sup> January 2018

The VAT Gap is defined as the difference between the VAT total tax liability (VTTL, sometimes also known as VAT total theoretical liability) and the amount of VAT collected. Figure 2 shows the amount of VAT Gap in 2014 and 2015. The highest Gap was recorded in Romania and Slovakia. Sweden's VAT revenues exceeded the estimated VTTL in 2015. The median in the EU-28 was 11%.



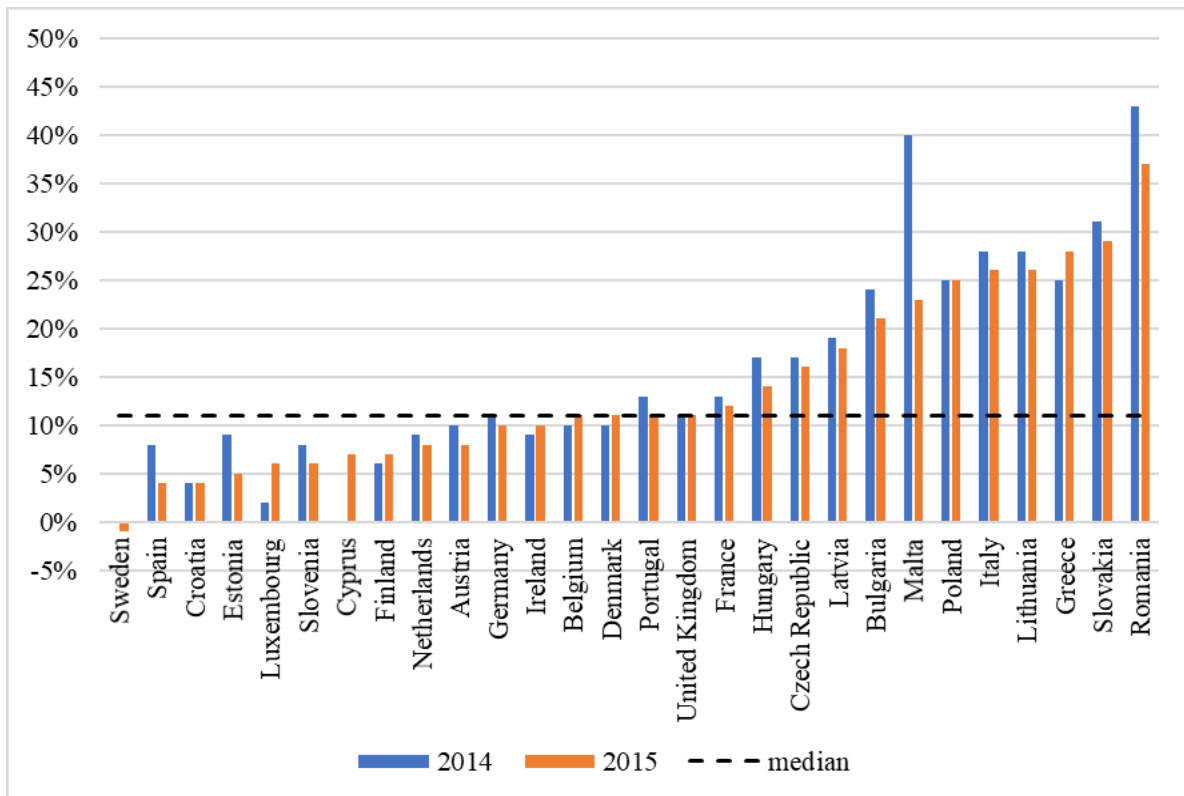

Figure 2: VAT Gap as a percent of the VTTL in EU-27 Member States, 2014 and 2015 (calculated according CASE)

In nominal terms, in 2015, the VAT Gap in the EU-28 amounted to EUR 151,5 billion. The VTTL accounted for EUR 1187,8 billion, whereas VAT revenue was EUR 1035,3 billion. In relative terms, the VAT Gap share dropped to 12,8 % down from 14,1 % in 2014 and was at its lowest value since 2011. In absolute values, the nominal VAT Gap has dropped by EUR 8,7 billion and is at its lowest value since then. Of the EU-27 (excluding Cyprus), the VAT Gap share decreased in 20 countries and increased in only 7 (Belgium, Denmark, Ireland, Greece, Luxembourg, Finland, and the United Kingdom).

Table following on the next page

Table 3: VAT GAP as a percent of VTTL in EU-28 (calculated according CASE)

Country	2011	2012	2013	2014	2015	Trend Graph
Belgium	12%	14%	12%	10%	11%	
Bulgaria	25%	21%	16%	24%	21%	
Czech Republic	17%	20%	19%	17%	16%	
Denmark	11%	10%	11%	10%	11%	
Germany	10%	11%	11%	11%	10%	
Estonia	12%	12%	14%	9%	5%	
Ireland	16%	16%	12%	9%	10%	
Greece	34%	29%	33%	25%	28%	
Spain	13%	10%	12%	8%	4%	
France	8%	12%	11%	13%	12%	
Croatia	na	na	na	4%	4%	
Italy	29%	29%	30%	28%	26%	
Cyprus	na	na	na	na	7%	
Latvia	32%	24%	24%	19%	18%	
Lithuania	29%	31%	29%	28%	26%	
Luxembourg	5%	4%	3%	2%	6%	
Hungary	21%	22%	21%	17%	14%	
Malta	41%	42%	41%	40%	23%	
Netherlands	10%	9%	10%	9%	8%	
Austria	11%	8%	10%	10%	8%	
Poland	21%	27%	26%	25%	25%	
Portugal	13%	16%	16%	13%	11%	
Romania	37%	39%	39%	43%	37%	
Slovenia	6%	9%	5%	8%	6%	
Slovakia	28%	38%	33%	31%	29%	
Finland	5%	5%	5%	6%	7%	
Sweden	3%	6%	2%	0%	-1%	
United Kingdom	9%	10%	10%	11%	11%	

#### 4. CLUSTER ANALYSIS

The objective of cluster analysis was to achieve such groups of states, which would be characterized by certain homogeneity. Cluster analysis sorted data into groups with the greatest possible similarity within the group and the largest difference between groups. The basic methods of clustering we used were:

- Hierarchical methods are based on sequentially joining of clusters, their number decreases continuously until finally all clusters are combined into one. The result is graphically displayed as tree diagram respectively cluster dendrogram.
- Ward's method involves an agglomerative clustering algorithm. It looks for groups of leaves that it forms into branches, the branches into limbs and eventually into the trunk. Ward's method starts out with  $n$  clusters of size 1 and continues until all the observations are included into one cluster. Ward's method uses the Euclidean distance.

There were  $p$  objects in the analyzed group, namely 28 countries in which were pursued  $k$  quantitative characters (3 variables). Three imputed variables were VAT Gap, Nominal Growth of Final Consumption and VAT Standard Rate in 2015 in EU-28.

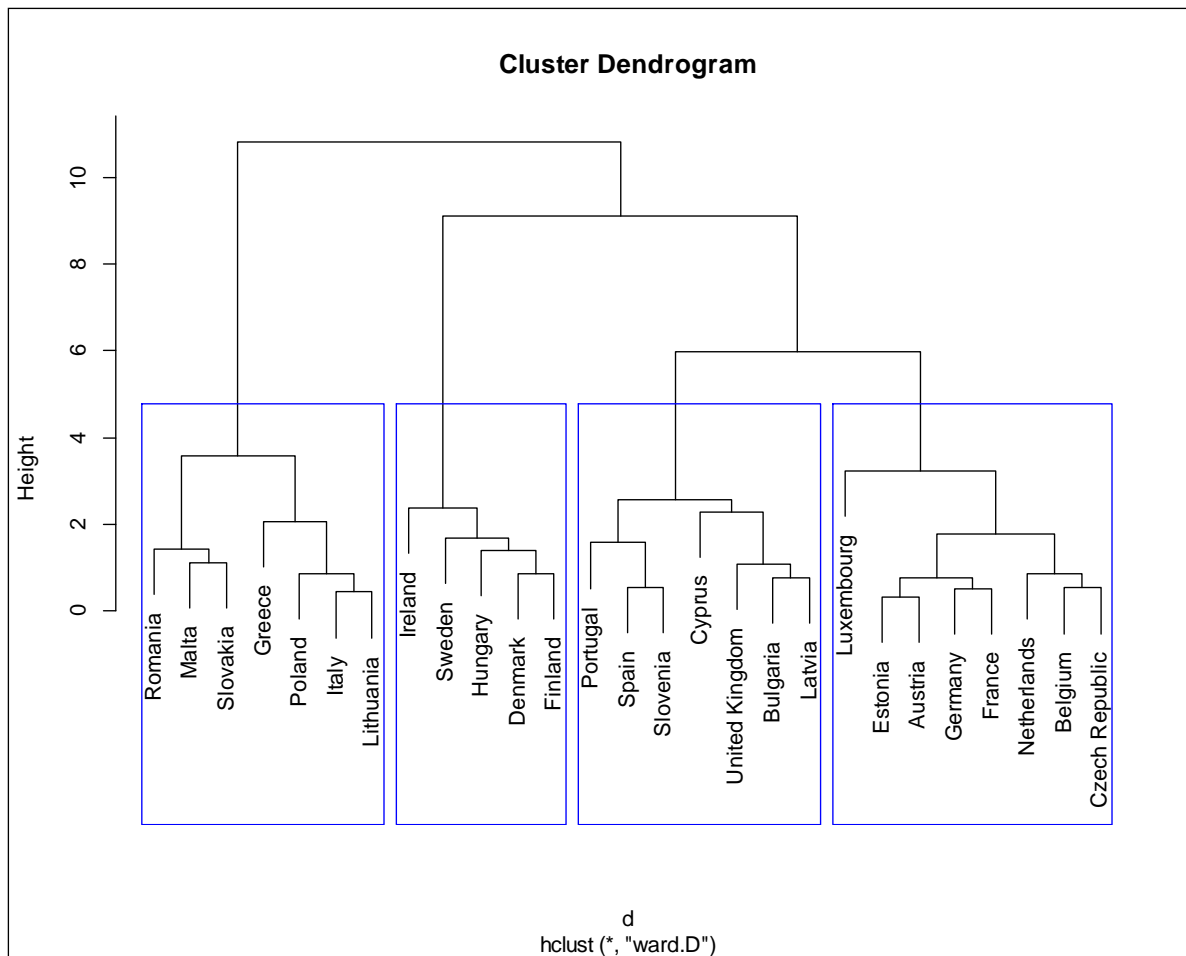

Figure 3: Cluster dendrogram according Ward's method (authors)

In the dendrogram (Figure 3) we can identify only four groups of countries with similar characteristics. These groups are highlighted.

## 5. CONCLUSION

Among EU Member States Romania and Slovakia belong to the countries with highest tax gap on Value Added Tax. The lowest VAT Gap in the EU-28 was in the last few years reported in Sweden, Croatia and Spain. There are few significant factors that affect VAT Gap in a state. It is especially the tax policy, tax rates, willingness and capacity to pay, and other macroeconomic indicators like final consumption of population, GDP growth etc. In the last few years several governments are trying to prevent tax evasion on VAT due to numerous measures like reduced VAT rate on basic groceries, restrictions on cash payments in business, tightened tax oversight for entities, sales receipt lottery, stricter controls of retailers and so on. But these are measures that help to reduce the tax gap only on a small scale. There are more effective tools and methods for reducing the VAT Gap. In several economies are employee salaries and wages undersized, there are too high differences between individual incomes groups, successful entrepreneurs are burdened by high taxes etc. To avoid tax evasion, it is necessary to create a more favorable business environment. These are the areas where we see the space for improvement. There might help the cluster analysis that had created clusters of countries with similar features. There are countries with poorer outcomes and countries with better results within the clusters. Therefore observing, learning and cooperation is the way forward, the way to improvement and rectification.

Cluster analysis fundamentally confirmed the intuitive division of countries during working on the paper. There are four groups of similar countries according to hierarchical clustering.

**ACKNOWLEDGEMENT:** *This Paper was elaborated within the framework of the project VEGA 1/0887/17.*

**LITERATURE:**

1. Alm J., Borders K. (2014). *Estimating the "Tax Gap" at the State Level: The Case of Georgia's Personal Income Tax*. Public Budgeting & Finance, Vol. 34 Issue 4.
2. CASE. (2017). *Study and Reports on the VAT Gap in the EU-28 Member States: 2017 Final Report*. Warsaw: CASE. Retrieved 25.09.2018 from [https://ec.europa.eu/taxation\\_customs/sites/taxation/files/study\\_and\\_reports\\_on\\_the\\_vat\\_gap\\_2017.pdf](https://ec.europa.eu/taxation_customs/sites/taxation/files/study_and_reports_on_the_vat_gap_2017.pdf).
3. European Commission–a. (2018). *VAT Gap: Frequently asked questions*. Brussels: EC. Retrieved 18.09.2018 from [http://europa.eu/rapid/press-release\\_MEMO-13-800\\_en.htm](http://europa.eu/rapid/press-release_MEMO-13-800_en.htm).
4. European Commission–b. (2018). *VAT rates applied in the Member States in the European Union*. Brussels: EC. Retrieved 15.09.2018 from [https://ec.europa.eu/taxation\\_customs/sites/taxation/files/resources/documents/taxation/vat/how\\_vat\\_works/rates/vat\\_rates\\_en.pdf](https://ec.europa.eu/taxation_customs/sites/taxation/files/resources/documents/taxation/vat/how_vat_works/rates/vat_rates_en.pdf).
5. European Parliament. (2013). *Report on Fight against Tax Fraud, Tax Evasion and Tax Havens, Committee on Economic and Monetary Affairs (2013/2060(INI))*. Strasbourg: EP. Retrieved 14.09.2018 from <http://www.europarl.europa.eu/sides/getDoc.do?pubRef=-//EP//TEXT%20REPORT%20A7-2013-0162%200%20DOC%20XML%20V0//EN>.
6. Eurostat. (2018). *National accounts data*. Brussels: EC. Retrieved 20.09.2018 from <http://ec.europa.eu/eurostat/web/national-accounts/data/database>.
7. GOV.UK. (2015). *Measuring tax gaps 2015 edition -Tax gap estimates for 2013-14*. Retrieved 14.09.2018 from [https://www.gov.uk/government/uploads/system/uploads/attachment\\_data/file/470540/HMRC-measuring-tax-gaps-2015-1.pdf](https://www.gov.uk/government/uploads/system/uploads/attachment_data/file/470540/HMRC-measuring-tax-gaps-2015-1.pdf)</Titre.
8. Poniatowski G., Bonch-Osmolovskiy M., Belkindas, M. (2017). *Reports on the VAT Gap in the EU-28 Member States: 2017 Final Report*. CASE – Center for Social and Economic Research. Poland. Retrieved 01.10.2018 from [http://www.case-research.eu/files/?id\\_plik=5284](http://www.case-research.eu/files/?id_plik=5284), 2017.
9. European Commission. (2013.) *Study to quantify and analyse the VAT Gap in the EU - 27 Member States*. Brussels: EC. Retrieved 02.10.2018 from [http://ec.europa.eu/taxation\\_customs/resources/documents/common/publications/studies/vat-gap.pdf](http://ec.europa.eu/taxation_customs/resources/documents/common/publications/studies/vat-gap.pdf).
10. Warren N., McManus J. (2007). *The Impact of Tax Gap on Future Tax Reforms*. Australian Economic Review, Vol. 40 Issue 2.

## THE LIABILITY OF LEGAL ENTITIES FOR CRIMINAL ACTS IN CROATIAN COURT PRACTICE

**Nina Misic Radanovic**

*University of Split,  
University Department of Forensic Sciences,  
Ruđera Boškovića 33, Split, Croatia  
nina.misic.radanovic@unist.hr*

### **ABSTRACT**

*The normative model of liability of legal entities for criminal acts in the Croatian legal system has already been present for almost fifteen years. The Republic of Croatia's legislation has completely harmonized this with the European one and in particular with the Anglo-American system in which types of liability had always been in place. The responsibility of a legal entity is founded on its individual (responsible) person and accepting the model of implemented liability with the theory of identification because the person responsible is identified with the legal entity and their acts and omissions are considered to be the acts/omissions of the legal entity. In Croatian legal criminal theory, a range of disputable issues of this type of liability have notionally been defined. An example of this is the circle of individual and legal entities liable which our court practice mainly accepts. However, research into the processing and structure of criminal acts of legal entities point to the fact that inquests and investigations of legal entities are lengthy; that a large number of reports are rejected because the informers are individual or legal entities who believe they are injured parties in a legal-civil way; that the court criminal policy towards legal entities is substantially different from the legislative; that the security measures are very rarely applied, just like confiscation of pecuniary gain and so on. Also, less legal entities are criminally reported than responsible individuals in these legal entities, which can be explained by the fact many legal entities have ceased to exist or by the fact a legal entity has several responsible persons. The structure of the acts of legal entities most commonly appearing in court practice shows that they are in particular from the area of white-collar crime. That is, mainly reported is fraud in business, abuse of trust in business, tax or customs evasion and so on. Then come acts against employment relations and social insurance, against the environment, against safety in general, against property, document forgery, against intellectual property and so on. Research into the judicature uncovers the existence of a kind of gap between normative solutions and their application in court practice.*  
**Keywords:** *liability of legal entities, legislative framework, criminal capacity, responsible individuals, economic crime*

### **1. NORMATIVE FRAMEWORK**

In the Republic of Croatia, material legal assumptions of the liability of legal entities for criminal acts are not prescribed in Criminal Code<sup>1</sup> but in a special Act on the Responsibility of Legal Persons for Criminal Offences (official gazette NN, 151/03, 110/07, 45/11, 143/12, further: ZOPOK). In this law are all the normative solutions on which legal entities have criminal liability, which individuals for whose acts a legal person is also responsible, according to which model of liability does punishability of legal entities exist, for which criminal acts are

---

<sup>1</sup> A great number of European states prescribe conditions for liability of legal entities in a Criminal Code, for example the Netherlands (Criminal Code of 1976), France (Code Penal of 1994), Italy (art. 197. Codice Penale) and so on. Republic of Slovenia firstly prescribed punishability of legal entities with its Crime Act of 1994 and in 1999 with a special *Act on Responsibility of Legal Entities for Criminal Acts*. More in Vermuelen and so on (2012). On European documents and legislative framework of criminal liability of legal entities in European states and on the Anglo-American concept of the type wider liability Horović, S., Mišić Radanović, N., pp. 181-185.

legal entities liable and by which legal criminal sanctions can legal persons be punished. However, due to also accepting the principle of subsidiary application of general criminal legislation on legal entities, ZOPOK is *lex specialis* which expressly prescribes subsidiary application of Criminal Code of the Republic of Croatia,<sup>2</sup> Criminal Procedure Act<sup>3</sup> and Act of Anti-Corruption and Organized Crime Prevention Office.<sup>4</sup> Therefore, ZOPOK in particular only regulates material and procedural questions that are specific for the liability of legal entities, while for all other questions all stated regulations of Croatian criminal legislation also apply to legal entities. The foundation for the liability of legal entities is established in art. 3 of ZOPOK and the legal entity is punished for the criminal act of the individual person responsible if it violates some duty of the legal entity or by that act the legal entity has gained or stood to gain illegal pecuniary gain for themselves or someone else. Also, liability of the legal entity is based on the guilt of the person responsible (art. 5 sec. 1 ZOPOK), and that is that person who runs the business of the legal entity or has entrusted him/her to run matters from the area of the legal entity's activity (art. 4 ZOPOK). At the same time, so called cumulation of liability is accepted for the same act which means that criminal liability of legal entities does not exclude the criminal liability of individuals.

### 1.1. Punishable legal entities

Pursuant to ZOPOK criminal liability only applies to entities whose legal entity is recognized by the legal order and those are companies, institutions, unions, associations, trade unions, political parties and so on as well as foreign persons who Croatian law recognizes as being legal entities (art. 1 sec. 2). In other words, societies which do not have the status of a legal entity, and in Croatian law these are only silent partnerships or secret companies,<sup>5</sup> partnerships and associations which do not have legal entity properties as well as legal entities in the making. These cannot be punished. Foreign legal entities are equalized with domestic ones. For deciding whether a foreign or domestic legal entity is concerned the criterion is where the headquarters are registered.<sup>6</sup> Given that the legislation which regulates company law and rights of societies for the permanent carrying out of activity in the Republic of Croatia prescribes the condition that the foreign legal entity must establish a head-office, ZOPOK will nevertheless also be applied to foreign legal entities when they do not have a representative body or branches in the Republic of Croatia as well as on those who are not legal entities pursuant to foreign law, but are pursuant to Croatian law.<sup>7</sup> To the circle of legal entities who have criminal capacity also belong local and regional units of self-government, political parties and trade unions.<sup>8</sup> Criminal liability of state and other public bodies in implementing government powers (*iure imperii*) is absolutely excluded because *ius puniendi* belongs exclusively to the state and it cannot punish itself. However, when local and regional units of self-government as territorial units of state act *iure gestionis* in economic business dealings, on the basis of authority of running business

---

<sup>2</sup> Crime Code, NN, 125/11, 144/12, 56/15, 61/15, 101/17 (further: CC).

<sup>3</sup> Criminal Procedure Act, NN, 152/08, 76/09, 80/11, 121/11, 91/12, 143/12, 56/13, 145/13, 152/14, 70/17 (further: CPA).

<sup>4</sup> Act of Anti-Corruption and Organized Crime Prevention Office, NN, 76/09, 116/10, 145/10, 57/11, 136/12, 148/13, 70/17

<sup>5</sup> Secret Society is a society where a secret member participates with pecuniary benefit role in a legal entity in order to share profit, but has no obligation towards third persons, making it merely a contractual obligation between a secret and public member.

<sup>6</sup> "A foreign company for the purposes of this law is a company which is validly established pursuant to the laws of the country wherein it has registered headquarters outside of the Republic of Croatia" (art. 611. sec. 1.), Company Act, NN 111/93, 34/99, 121/99, 52/00, 118/03, 107/07, 146/08, 137/09, 125/11, 152/11, 111/12, 68/13, 110/15 In more detail: Horović, S., Mišić Radanović, N. p. 186.

<sup>7</sup> Art. 611 sec. 1 and art. 612. sec. 2 of the Company Act. On the reason for this type of extensive organization in relation to punishing foreign legal entities see Đurđević, Z. p. 751.

<sup>8</sup> In this way do all legal entities answer before French Criminal Law with the exception of the state be they either legal public (public institutions, public interest groups), legal private (groups directed at acquiring profit as a society, economic interests groups or those which are not aimed at acquiring profit such as associations, trade unions, foundations) or mixed (professional circles, associations for agrarian exploitation and populating rural areas). Cartier, M. E., p. 283.

matters, they are criminally liable because they can entrepreneurially contract on buying, selling, public procurement and so on.<sup>9</sup>

## **1.2. Responsible individuals for whose acts legal entities are also liable**

As already stated, a responsible person is that legal entity who runs business affairs or to whom the running of business affairs from the area of activity of the legal entity is entrusted. These are firstly persons who can conclude legal dealings for the legal entity and thereby commit a criminal act.<sup>10</sup> This involves individuals who are authorized to represent the legal entity on the basis of the law, statute, contract, management decision or proxy. However, besides these persons the individual and every legal entity to whom carrying out business affairs from the legal entity's area of activity is entrusted.<sup>11</sup> Thereby, in establishing who the responsible person is, the modified identification model (alter ego) that is model of delegation is accepted<sup>12</sup> opening up a wide possibility of criminal liability of legal entities. Furthermore, if the responsible person committed the criminal act for their own personal gain or against the interests of the legal entity, there is only the personal criminal punishability of that individual and not of the legal entity.<sup>13</sup> In that way, for example, the legal entity can suffer damages from embezzlement by their employee.

## **1.3. Principle of the guilt of legal entities**

Given that ZOPOK has accepted accessory and subjective legal entity liability which depends on the responsibility of the liable person, legal entity liability rests on the model of calculating the guilt of the responsible person to the legal entity. Therefore, in Croatian legal system the classic theory of identification has been accepted, that is the theory of borrowed guilt.<sup>14</sup> The guilt of the legal entity emerges from the guilt of the responsible person which means that with the legal entity as the responsible person all the ingredients of guilt must be present.<sup>15</sup> However, pursuant to art. 5 sec. 2 of ZOPOK there is the possibility that the legal entity is punished for the criminal act by the responsible person also in the case where the existence of legal or real obstacles for establishing the liability of the responsible person in which case the guilt of the responsible person is assumed, but proving that the responsible person is not guilty is allowed. Such a solution in Croatian criminal law introduces the only exception to the presumption of innocence, which theoretically justifies the necessity of punishing legal entities also in cases when the responsible legal entity is unknown or inaccessible.<sup>16</sup>

---

<sup>9</sup> For example, carrying out local community activities such as transport, collecting rubbish, maintaining open space, cemeteries, public lighting and so on via own companies.

<sup>10</sup> On authority for carrying out jobs in companies in more detail Barbić, J., pp. 3-44. Similarly, in Katušić-Jergović, pp. 131-182.

<sup>11</sup> Thereby harmonization with the concept of the responsible person is achieved from art. 87 sec. 6. C.C. When establishing which individual is responsible in the legal entity, a knowledge of all legal and sub-legal regulations which regulate the structure and functioning of that legal entity is necessary.

<sup>12</sup> The model of delegation widens liability to those persons to whom leading persons have assigned responsibility for managing or have entrusted the carrying out of certain tasks.

<sup>13</sup> More on the concept of liability of persons in theory and foreign legislations Horović, S., Mišić Radanović, N. pp. 187-189.

<sup>14</sup> On the issue of legal entity guilt in European and Anglo-Saxon countries are numerous theories or various models of legal entity criminal liability. On autonomous or corporative guilt, implemented or borrowed guilt, theories of aggregation and identification, guilt because of omitted reaction and so on. In more detail Đurđević, Z., pp. 740-743., Boisvert, A., p. 12., Savić, V. p. 65., Ku, M. and Pepper, L., p. 284.

<sup>15</sup> All circumstances which affect legal entity guilt, whether they exclude or merely soften, are transferable and influence guilt and legal entities, by which legal entity liability is made compliant with the principle of guilt. See Horović, S., Mišić Radanović, N., p. 195.

<sup>16</sup> For example, in cases in which the individual who has committed the act cannot be found or proceedings cannot be conducted against that person because they have absconded or died.

#### **1.4. Structure of crime of legal entities**

ZOPOK has not, as opposed to the Slovenian<sup>17</sup> and French legislation, taxatively listed the criminal acts for which legal entities are held accountable, that is, a special catalogue of acts has not been proscribed in the belief that, by the nature of things, they cannot be held responsible for all criminal acts.<sup>18</sup> Given that the principle of legality and legal safety demands taxative regulation of criminal acts so that legal entities in advance can know for which criminal acts they could answer, it was necessary for ZOPOK to prescribe additional criteria for establishing for which criminal acts legal entities could answer. Thus, the Croatian solution partially matches Anglo-American law which has left resolving this issue up to court practice. Therefore, extra criteria for determining crime by legal entities pursuant to ZOPOK is that crime committed by a responsible person has violated some duty of the legal entity or by that act the legal entity has gained some illegal pecuniary gain for themselves or others.<sup>19</sup> For example, the violation of some duty of the legal entity exists if the cause of commission of the act represents a violation of some legal or sub-legal provision which stipulates some duty to the legal entity. The lucrative nature of this criminal act consists in achieving benefit for that legal entity or for someone else, for example, as in fraud in business. The criminal act is committed at the expense of the legal entity when it concerns the totality of its constituents or organs, members or to a lesser extent its employees and affects all of them.<sup>20</sup>

#### **2. CRIMINALITY OF LEGAL ENTITIES IN CROATIAN COURT PRACTICE**

The aim of this implemented research was to establish which criminal acts are reported and legal entities punished in Croatian judicature and to attempt to define the concept of the criminality of legal entities in Croatia.<sup>21</sup>

*Table following on the next page*

---

<sup>17</sup> „In a special part of the Bill on Liability of Legal Person for Criminal Offences are defined those criminal offences for which a legal person can be liable and provided sentences for criminal offences. Legal persons may be liable for criminal offences from the special part of PC and respectively PC-I and for other criminal offences, if so provided by the Bill. In Article 25 of this Bill are listed all criminal offences from the special part of PC and respectively PC-I, for which a legal person can be held liable.“ Jakulin, V., p. 8. Similarly, in Bele, Deisinger, Balažić, p. 37.

<sup>18</sup> The general liability approach is prevalent in common law world, while civil law countries have historically tended to prefer specific liability approaches. Although the latter approach prevails in most ACN (Anti-Corruption Network) countries, in five states Bosnia and Herzegovina, Croatia, Montenegro, Romania and Serbia corporate liability can arise for all offences specified in the penal code. OECD Anti-Corruption Network for Eastern Europe and Central Asia, *Liability of Legal Persons for Corruption in Eastern Europe and Central Asia*, 2015., p. 32.

<sup>19</sup> Basically, the Slovenian legislator also links legal entity liability with additional criteria: A legal person shall be liable for a criminal offence committed by the perpetrator in the name of, on behalf of or in favour of the legal person in the following cases: 1. if the committed criminal offence means carrying out an illegal resolution, order or endorsement of its management or supervisory bodies; 2. if its management or supervisory bodies influenced the perpetrator or enabled him to commit the criminal offence; 3. if it obtains by a criminal offence an illegally property gain or objects gained through a criminal offence; 4. if its management or supervisory bodies have omitted obligatory supervision of the legality of the actions of employees subordinate to them.). Cit. Jakulin, V., p. 5.

<sup>20</sup> Cit. Cartier, M. E., p. 290.

<sup>21</sup> Overview of practice contains data from the Republic of Croatia State Attorney (further: DORH) and the Municipal State Attorney in Split (further: ODO Split).



*Table 1: Reported legal entities 2013 - 2017*

<b>Year</b>	<b>Municipal and County State attorney</b>	<b>Anti- Corruption Organized Crime Prevention Office</b>	<b>Total</b>
<b>2013</b>	41	26	710
<b>2014</b>	38	18	912
<b>2015</b>	33	12	1331
<b>2016</b>	19	80	1431
<b>2017</b>	131	39	1263

*The number of reported legal entities to municipal and county State Attorneys and Anti-Corruption and Organized Crime Prevention Office.<sup>22</sup> Source: Report from Republic of Croatia State Attorney for the year 2017.*

*Table following on the next page*

---

<sup>22</sup> The number of reported complaints against legal entities is always less than against persons in those legal entities which can be explained by the fact that a large number of legal entities have ceased to exist or because a legal entity may have several responsible persons

*Table 2: Structure of legal entity criminality*

<b>Name of the criminal act</b>	<b>2016</b>	<b>2017</b>	
C. A. AGAINST EMPLOYMENT RELATIONS AND SOCIAL WELFARE	200 14%	178 14.1%	
C.A. AGAINST THE ENVVIRONMENT	23 1.6%	20 1,6%	
C. A. AGAINST PUBLIC SAFETY OF PERSONS AND PROPERTY	41 2.9%	46 3.6%	
C. A. AGAINST PROPERTY	171 11.9%	145 11,5.%	
C. A. AGAINST THE ECONOMY	796 55.6%	700 55.4%	
C. A. FORGERY	37 2.6%	44 3.5%	
C. A. AGAINST OFFICIAL DUTY	63 4.4%	72 5.7%	
OTHER CRIMINAL ACTS FROM C.C. AND SPECIAL LAWS	100 7%	58 4.6%	
<b>TOTAL:</b>	1431 100%	1263 100%	

*Criminal acts for which legal entities reported. Source: Report from the State Attorney of the Republic of Croatia for the year 2017*

The data shows that, with a natural person as the person responsible in companies, more and more applicant reporting legal persons for committing criminal offenses and in the five-year period from 2013 to 2017 there has been an increase in the number of reported legal entities. Furthermore, the structure of crimes has not changed. Over half of reported acts by legal entities are criminal acts against the economy because by them, legal entities have gained illegal pecuniary benefit for themselves or others. The case is the same with reports against legal entities for criminal acts against property (mainly for acts of fraud from art. 236 of the C.C.). In second place are reports for criminal acts against employment relations and social welfare insurance (mainly for the act of not paying wages from art. 132 of the C.C.), against official duties (mainly for abusing one's position and authority, art. 291 of the C.C.), for forging

documents, against public safety of persons and property and against the environment, because with these acts responsible persons have violated some legal entity duty.<sup>23</sup>

*Table 3: Decisions on reports against legal entities for 2017*

Decision to dismiss crime report	861	78.5%
Decision to lead an investigation	85	7.7%
Direct indictment	83	7.6%
Decision for other action (amalgamation or concession)	68	6.2%

*Structure of decisions according to reports. Source: Report from the State Attorney of the Republic of Croatia for the year 2017*

A large percentage of dismissed criminal charges is common for reported crime of legal entities. Reasons for this lie in several facts related to the structure of reported crime and in *ZOPOK* and the prescribed material and procedural assumptions for liability and leading proceedings against legal entities. Given the structure of legal entity criminology in which economic criminal acts dominate, it often occurs that reports are made by individual or legal entities who consider themselves to be injured parties in some civil or company or business relation and in principle after investigation or evidence procedures are carried out, it can be established that the matter is not at all a criminal act or that it is impossible to prove, for example so called fraudulent intentions on the part of the responsible person in the legal entity. In other words, the reason for dismissal is establishing that in the actions of the reported person, no characteristics of a criminal act exist<sup>24</sup>, but rather it concerns unresolved civil relations which have emerged from business relations because of which injured parties by making a criminal report try to get back what is owed to them.<sup>25</sup> Furthermore, with some criminal acts, for example tax or customs evasion from article 256 of the C.C., dismissal of charges against the legal entity occurs most often because the legal entity ceases to exist or because of some other circumstances which are a procedural obstacle to initiating criminal proceedings or are reason to halt proceedings against the legal entity. An interest piece of data is that injured parties after receiving notification that charges have been dismissed very rarely instigate criminal prosecution.<sup>26</sup>

*Table 4: Judicial decisions on indictments against legal entities in the year 2017*

conviction	acquittal	reject the charge
70      63.6%	21      19.1%	19      17.3%

*Source: Republic of Croatia State Attorney for the year 2017*

<sup>23</sup> Besides 128 reports against legal entities for white collar criminal acts, the ODO in Split in 2017 received 12 reports for acts against the environment, 11 for criminal acts against public safety of persons and property, 10 for criminal acts against property, 4 for forgery, 3 for criminal acts against intellectual property, 5 for criminal acts against official duty and so on and 1 for a criminal act against personal freedom.

<sup>24</sup> For example, in the criminal act of not paying owed wages from art. 132. of C.C. not paying owed wages mostly occurred because of not being able to have power over funds in the employer's account so because of that pursuant to provision of art. 132 sec. The characteristics for this criminal act were not created.

<sup>25</sup> Legal dealings were only exceptionally modified into a criminal act. When legal dealings become criminal see in more detail Pavlović, Š., pp. 71-130.

<sup>26</sup> Cit. According to annual reports of ODO in Split for 2017.

And this table shows that success of accusations in proceedings against legal entities percentage wise is lower than success in accusing individuals. In fact, there was a decrease in the share of convictions in relation to the previous period in which the convictions accounted for 75.4% of judgments rendered.<sup>27</sup> Data shows that 78.6% of convictions against legal entities received sentence of a monetary fine while a suspended sentence was applied in the remaining 21.4% of verdicts. Together with convicting verdicts, the court also applied the measure of taking away pecuniary benefit from the legal entity.<sup>28</sup> An interesting piece of data is that in 2017 there was not one decision handed down that the legal entity be forced to cease to exist.<sup>29</sup>

*Table 5: Structure of reported economic criminal acts (white collar crime) in 2017*

	DORH	ODO Split
c.a. abusing trust in business dealings, art. 246 C.C	130	3
c.a. fraudulent business dealings, art. 247 C.C	421 <sup>30</sup>	107
c.a. violation of duties of running company or business books from article 248 C.C	10	1
c.a. causing bankruptcy, art. 249 C.C	10	-
c.a. tax or customs evasion, art. 256 C.C	108	15
c.a. subvention fraud, art. 258 C.C.	7	-

*\*According to data from 2017 by the Municipal State Attorney in Split one legal entity has been reported for the criminal act of favouring creditors from art. 250 of the C.C. and betraying and authorized use of business secrets from art. 262 of the C.C.*

*Source: Republic of Croatia State Attorney for the year 2017*

Among the economic criminal acts<sup>31</sup> for which legal entities were most reported for<sup>32</sup>, two parts are most represented – fraud in running business dealings (art. 247 of C.C.) and abuse of trust in running business dealings (art. 246 of C.C.).

<sup>27</sup> Data on number of reported, charged and convicted legal entities from 2005 to 2014 see Horović, S., Mišić Radanović, N., p. 196.

<sup>28</sup> During this reporting period, 2,989,613.38 kuna was seized from legal entities, which is much less than in the previous period. The reason for this is not only just the smaller number of convicted legal entities, but the inability to seize their pecuniary benefit from them, either because of the cessation of their business, or because establishing that they had no property. In these cases, the State Attorney submitted property requests against responsible persons for damages the same criminal act was done to the State Budget. Cit. Report by Republic of Croatia State Attorney for the year 2017, p. 155.

<sup>29</sup> Pursuant to art. 12 of *ZOPOK*, the punishment of annulling the legal entity can be handed down if the legal entity primarily works on perpetrating criminal acts or used its activities mainly to perpetrate criminal acts. This cannot be handed down to unity of local and regional self-government and political parties.

<sup>30</sup> According to DORH in 2017 in relation to the previous period a significant reduction of the number of reported legal entities has occurred for criminal acts of fraud in business dealings from article 247 of the C.C. by 127 persons or 23.2% less, and also an increase in the number of reported legal entities for the criminal act of abuse of trust in business dealings from article 246 of the C.C. (by 25 more persons or 2.8% more).

<sup>31</sup> The biggest number of these acts is completely logical because while collar criminal acts are mainly the criminal acts of entrepreneurs and these are mostly companies as legal entities. Novoselec, P., p. 7.

*"Business activity is understood to be systematic activity which is independently carried out for the purpose of making a profit by an entrepreneur in his own name, and at his own liability"*. In more detail Žatecká, E., p. 2984.

<sup>32</sup> Data on the structure of criminal acts of convicted legal entities show that a part of white-collar criminal acts against the economy in convicted legal entities is extremely high from 65.0% up to 74.0% of all convictions. In more detail Horović, S., Mišić Radanović, N., p. 196.

Both acts in their legislative description have characteristics of illegally gaining pecuniary benefit for themselves or someone else, that is, for the legal entity.<sup>33</sup>

Table 6. Processing economic criminal acts (white collar crime) in 2017

	Other	New reports received	Total number of reports	Dropped art.206 CPA and so on	Direct Indictment	Court order to instigated investigation	Reported complaints resolved in another way	Total number of decisions resulting from reported complaints	Total of unresolved reported complaints	Indictment	Conviction	Acquittal	Dismissal	Total number of decisions	Fines	Safety measures from ZOPOK	Seizure of Pecuniary Benefit
fraud in economic business	30	77	107	81	1	4	1	87	20	1	1	1	-	2	1	-	-
abuse of trust in business dealings.	-	3	3	2	-	-	-	2	1	-	-	-	2	2	-	-	-
tax or customs evasion	2	13	15	1	1	-	1	3	12	-	2	-	-	2	2	-	-
<b>Total</b>	<b>32</b>	<b>93</b>	<b>125</b>	<b>84</b>	<b>2</b>	<b>4</b>	<b>2</b>	<b>92</b>	<b>33</b>	<b>1</b>	<b>3</b>	<b>1</b>	<b>2</b>	<b>6</b>	<b>3</b>	<b>0</b>	<b>0</b>

Source: Annual Report Municipality State Attorney Split for the year 2017

### 3. CONCLUSION

Legal entity criminology according to collected data represents economic crime. Legal entities through their responsible individuals commit criminal acts gaining or were to gain illegal pecuniary benefit for themselves or others. Although the legislative should not in the interests of freedom to contract and the principles of disposability too broadly criminalize the actions of participants in company and contractual relations, research into the structure of legal entity criminology shows that it concerns the so-called classic form of „white collar crime” where legal entities act like legal participants in business. That is, the nature and aims of corporate criminal acts, in which there is no violence, physical violation and grievous bodily harm against individual legal goods, shows that the perpetrators in achieving their criminal aims, use their position, reputation and social status. Given the initiating motive, criminology of legal entities according to the nature of things belong to the rational and professional form of criminal activities. It is precisely these criminal characteristics that hinder uncovering perpetrators and the processing of them. Given that legal entities are legal creations, the covertness of their crime represents a great danger in the sense of its increasing organization. The research of Croatian practice in the uncovering and processing of legal entities for criminal acts reveals the existence of a certain gap between normative solutions and their practice. There are fewer criminal reports against legal entities than against responsible persons in these legal entities. Investigation into legal entities lasts for a long time. The number of rejected criminal reports is large.

<sup>33</sup> Fraud in business dealings (art. 247. of C.C.): *S/he who in business dealings with the aim of gaining illegal pecuniary benefit for the legal entity that person represents or for another legal entity creates or hides false or misleading facts incurring misrepresentation resulting in losses against their own or others' property by act or omission.* Abuse of trust in business dealings (art. 246 of the C.C.): *S/he who in business dealings breaches the duty of protecting others' economic interests founded by law, by administrative or judicial authority decision, legal dealings or relations of trust and in that way gains for themselves or another person illegal pecuniary benefit and thereby or by another way causes losses for the person whose property s/he is bound to protect..*

Court policy of punishing legal entities differs greatly from the legal one because mainly suspended monetary fines are handed down. The most serious decision to close down the legal entity is never passed and safety measures are almost never applied. Pecuniary benefit gained by the legal entity by the criminal act of their responsible person is never seized and so on. All of the above shows that perhaps the time has come for the difficulties in uncovering and punishing legal entities be superseded by certain specialized state attorneys and judges. This would reduce the gap between legislations and the judicature.

#### LITERATURE:

1. Barbić, J. (2002), *Ovlast za vođenje poslova u trgovačkim društvima*, Aktualna pitanja kaznenog zakonodavstva, IV. Savjetovanje, Zagreb, str. 3-44.
2. Bele, Deisinger, Balažić (2000), *Zakon o odgovornosti pravnih oseb za kazniva dejanja s komentarjem*, Ljubljana.
3. Boisvert, A. (1999), *Corporate Criminal Liability*, Uniform Law Conference of Canada.
4. Cartier, M. E. (2005), *Kaznenopravna odgovornost pravnih osoba u francuskom pravu*, Hrvatski ljetopis za kazneno pravo i praksu, vol. 12, broj 2.
5. Đurđević Z. (2003), *Kaznena odgovornost i kazneni postupak prema pravnim osobama u Republici Hrvatskoj*, Hrvatski ljetopis za kazneno pravo i praksu, vol. 10, broj 2, str. 719-770.
6. Horović, S., Mišić Radanović, N. (2016), *Deliktna odgovornost pravnih osoba u poredbenom i pozitivnom zakonodavstvu i sudskoj praksi*, Zbornik radova "Aktualnosti građanskog i trgovačkog zakonodavstva i pravne prakse", Mostar, br. 14, str. 180-203.
7. Jakulin, V., *The criminal liability of legal persons in the Republic of Slovenia*. Dostupno na: <https://www.law.muni.cz/sborniky/dp08/files/pdf/trest/jakulin.pdf>
8. Katušić-Jergović (2002), *Prilog razmatranju o kaznenoj odgovornosti odgovornih osoba u trgovačkim društvima kapitala*, Aktualna pitanja kaznenog zakonodavstva, IV. Savjetovanje, Zagreb, str. 131-182.
9. Ku, M. i Pepper, L. (2008), *The Collective Knowledge Doctrine*, American Criminal Law Review, Georgetown University.
10. Novoselec, P. (2009), *Uvod u gospodarsko kazneno pravo*, Zagreb.
11. OECD Anti-Corruption Network for Eastern Europe and Central Asia (2015), *Liability of Legal Persons for Corruption in Eastern Europe and Central Asia*. Dostupno na: <https://www.oecd.org/corruption/acn/ACN-Liability-of-Legal-Persons-2015.pdf>
12. Pavlović, Š. (2002), *Modifikacija pravnog posla u kazneno djelo*, Aktualna pitanja kaznenog zakonodavstva, IV. Savjetovanje, Zagreb, str. 71-130.
13. Savić, V. (2011), *Koncept autonomne odgovornosti pravne osobe i njegova primjena u kaznenom pravu*, Godišnjak Akademije pravnih znanosti Hrvatske, vol. 2, no. 1.
14. Vermuelen i dr. (2012), *Liability of Legal Persons for Offences in the EU*, Antwerpen.
15. Žatecká, E. (2013), *Selected Aspects of Criminal Liability of Legal Persons*, ACTA UNIVERSITATIS AGRICULTURAE ET SILVICULTURAE MENDELIANAE BRUNENSIS, Volume LXI, No. 7. Dostupno na: <https://acta.mendelu.cz/media/pdf/actaun>

## A MULTIDIMENSIONAL APPROACH TO VALUE MANAGEMENT IN A SMALL AND MEDIUM-SIZED ENTERPRISE

**Ewa Mackowiak**

*Department of Accounting, University of Economics in Katowice, Poland  
ewa.mackowiak@ue.katowice.pl*

**Iwona Kumor**

*Department of Accounting, University of Economics in Katowice, Poland  
iwona.kumor@ue.katowice.pl*

### **ABSTRACT**

*An enterprise is an economic entity established with the purpose of conducting economic activity. In compliance with legal regulations in Poland, this involves for-profit manufacturing, construction, commercial and service activity as well as prospection, exploration and extraction of mineral reserves as well as professional activity carried out in an organized and continuous manner<sup>1</sup>. The necessity of self-financing and market competition forces enterprises to constantly search for new manufacturing, technical, organizational and financial solutions as well as to improve their financial performance. In these conditions, the basic characteristics of an enterprise are<sup>2</sup>:*

- a) volatility resulting from the need to constantly adapt to market conditions,*
- b) uncertainty and the resulting risk inherently involved with an enterprise's operations,*
- c) economic rationale of decisions and the systematic and professional nature of the conducted activity,*
- d) the need to sustain innovation and entrepreneurship in an enterprise's activity.*

*Economic sciences encompass, on the one hand, theories related to economic growth and development and, on the other, enterprise development theories. These theories come together with the concept of "value"<sup>3</sup>. In the late 20<sup>th</sup> century, theoreticians and practitioners of management began to advocate a closer connection of company management with creating shareholder value. Shifting the focus from maximizing profit to maximizing value for owners changed the approach to assessing the performance of an enterprise. Business management that is focused on stimulating value maximization for owners is referred to as Value Based Management (VBM). It points to the need to maximize value for all stakeholders. It is a "management philosophy that uses analytical tools and processes to bring individual objects of an organization around creating value for owners"<sup>4</sup>.*

**Keywords:** *Value of enterprise, small business, Value Based Management*

### **1. INTRODUCTION**

Both in the source literature and in business practice the expressions such as "a micro enterprise", "a small enterprise" and "a medium-sized enterprise" can be encountered. The most characteristic features of a small enterprise comprise<sup>5</sup>:

---

<sup>1</sup> Cf. W. Janik, A. Paździor, Zarządzanie finansowe w przedsiębiorstwie, Politechnika Lubelska, Lublin 2011, p. 9;

<sup>2</sup> Cf. R. Borowiecki, A. Jaki, J. Kaczmarek, Metody i procedury wyceny przedsiębiorstw i ich majątku, wyd. PSB, Kraków 1997, p.21;

<sup>3</sup> Cf. A. Gondek, Wartość, jako kategoria łącząca teorie wzrostu gospodarczego z teoriami przedsiębiorstw w: Zeszyty Naukowe Uniwersytetu Szczecińskiego nr 855, Finanse Rynki Finansowe, Ubezpieczenia No. 74, Vol. 2, Szczecin 2015, p. 223;

<sup>4</sup> Cf. Dudycz T. Zarządzanie wartością przedsiębiorstwa, PWE Warszawa 2005, p. 18;

<sup>5</sup> Cf. Raport o stanie sektora MŚP w Polsce, 2016, s. 98; M. Dylewski (red.), Finanse małych i średnich firm. Innowacje, decyzje, procesy, CeDeWu, Warszawa 2016, pp. 12-13;

1. połączenie funkcji właścicielskich z kierowniczymi pełnionych przez jedną osobę (właściciela) lub kilka osób (współwłaścicieli) powoduje, że wykonuje on wszystkie funkcje zarządzania, a więc funkcję planowania, organizowania, motywowania i kontrolowania; właściciel – kierownik jest zwykle założycielem; jedność zarządzania i własności ogranicza koszty utraconych możliwości i jednocześnie przeciwdziała istnieniu sprzecznych celów,  
joint ownership and managerial functions performed by one person (owner) or several persons (co-owners), which causes that one person performs all management functions, such as planning, organizing, motivating and controlling; the owner-manager is also usually the founder; the unity of management and ownership reduces the costs of lost opportunities and, at the same time, prevents the emergence of conflicting goals,
2. scarce sources of income,
3. a simple and unsophisticated organizational structure, stemming from the existence of one main decision-making center, a short information flow path, direct communication in the entity and a limited degree of delegation and empowerment,
4. decision-making autonomy of the owner or co-owners (often family members); this autonomy is expressed in the independent and free pursuit of ideas and managerial functions; it is increased by the absence of institutionalized forms of internal control, so the owner operates at his own risk and is not subject to third party supervision; this is evidenced by the results of the survey conducted by the Polish Agency for Enterprise Development in 2016, according to which in the majority (94%) of family businesses the owner manages the enterprise single-handedly, while the involvement of other family members in a firm's management is assessed as significant (27%) or very significant (47 %),
5. a simple accounting system,
6. a relatively small market share, limited mainly to a regional or local market; the activity often entails one product or one type of services provided; it is characterized with high flexibility, which makes it possible to respond quickly to the changing environment and tailor a firm's activity to the individual needs of clients;
7. the absence of an extensive administrative structure,
8. limited access to sources of funding, as evidenced by the results of the survey conducted by PARP, for example, in 2016, according to which the majority of investment expenditure of small enterprises is financed with own funds (64%), while only one fifth with loans and credit lines (18.1%); this is due to the costs of raising capital and the requirements of capital providers, the fulfillment of which is often problematic for a small enterprise; the aversion to the use of borrowed capital may also stem from the reluctance of owners to use external sources of funding, as this hinders their freedom,
9. a network of personal interactions with contractors; small firms conduct transactions mainly within a narrow circle of contractors, with whom they tend to develop closer contacts, which results in favorable cooperation relationships

## **2. SMALL AND MEDIUM-SIZED FIRMS IN POLAND**

Currently, 1.84 million of non-financial enterprises, referred to as active enterprises, operate in Poland. The majority, i.e. 99.8%, are firms that belong to the group of micro, small and medium-sized entities. When assessing trends concerning firms operating in Poland, a steady upward trend in the number of entities can be observed. In 1997, 1.58 million firms were active, in 2013 – 1.77 million, while 2014 saw a 4% increase in the number of economic entities, and in 2015 1.91 million firms existed in Poland. In 2015, compared to the previous year, one of the highest increases in the number of non-financial enterprises in recent years was reported – of almost 4%, and in the period 2011-2015, the increase in the number of enterprises reached 7.3%. The Polish sector of enterprises is dominated by microenterprises, whose share in the



structure of all enterprises amounts to as much as 96%. The recent years have seen a rise in the number of micro-enterprises. At present, over 1.8 million operate in Poland, which is 7% more than in 2008. Following the decrease reported in 2013, the years 2014-2015 saw a significant increase in their number (by 4% y/y). The largest number of microenterprises operate in services (52%) and trade (26%). They have the largest share in generating GDP. In addition, they have a significant impact on the labor market – they provide 39% of jobs in the sector of enterprises (the number of employees of such firms is approx. 3.7 million people). In 2015, they allocated almost PLN 30 billion to investment activity (14% of the entire sector of enterprises). Compared to other groups of enterprises, microfirms are the most productive (the ratio of results to expenditure), cost-effective (the ratio of costs to revenues), and profitable. Unfortunately, the majority concentrates exclusively on the domestic market – they rarely export/import and the share of exports/imports in their revenues/costs is quite low. They are also characterized by lower sustainability – the average of two-thirds stay in business after the first year, while in the next years their situation tends to be more difficult than this of other entities. Nevertheless, the share of the oldest entities, operating in the market for 5 or more years, is growing in the total number of microfirms, which may be indicative of an improvement in their situation<sup>6</sup>. Small and medium-sized enterprises operating in the market generate basic economic effects, which include<sup>7</sup>:

1. productivity effect – productivity of capital expenditure in small enterprises is at a lower level than in large enterprises, which is related to the fact that for the same level of production, a smaller enterprise usually needs less capital than a large company,
2. employment effect – in the sector of small and medium-sized enterprises the cost of new jobs is usually lower than in large companies, and in the case of an economic slowdown, job security is also higher in smaller entities,
3. technical progress effect - related to the development of product or process innovations, which is an important determinant of competitiveness in small companies,
4. regional decentralization effect – small and medium-sized enterprises tend to operate on a local scale and support the development of a given region, contributing to the activation of local communities and improving living conditions,
5. capital mobilization effect – funds involved in the foundation and development of small enterprises become productive capital, which means that without these enterprises, capital would be unused and remain unproductive in the economy,
6. stabilizing effect – in the period of economic downturn or recession, small enterprises perform better,
7. ecological effect – associated with the thesis that small enterprises, due to their decentralized and less aggressive nature, have a lower negative impact on the environment than larger entities.

### **3. VALUE MANAGEMENT IN SMALL AND MEDIUM-SIZED ENTITIES**

Value management in SMEs requires control on three levels:

1. Employed capital,
2. Operating profit,
3. Cash.

The first level of the value management system, based on the categories of working capital and employed capital, efficiently provides comprehensive information, which – in the case of

---

<sup>6</sup> Cf. Raport o stanie małych i średnich przedsiębiorstw 2017,

[https://webcache.googleusercontent.com/search?q=cache:SDwwhXd2C9wJ:https://www.parp.gov.pl/images/PARP\\_publications/pdf/raport%2520o%2520stanie%2520sektora%2520msp%2520w%2520polsce\\_2017.pdf+%cd=6&hl=pl&ct=clnk&gl=pl&client=firefox-b](https://webcache.googleusercontent.com/search?q=cache:SDwwhXd2C9wJ:https://www.parp.gov.pl/images/PARP_publications/pdf/raport%2520o%2520stanie%2520sektora%2520msp%2520w%2520polsce_2017.pdf+%cd=6&hl=pl&ct=clnk&gl=pl&client=firefox-b)

<sup>7</sup> Cf. M. Matejun, Zarządzanie małą i średnią firmą w teorii i w ćwiczeniach, Difin Warszawa 2012, pp.27-29;

problems with working capital or total financing – will indicate where irregularities occur. Working capital and total financing, or in fact their level, are of great importance, especially in the case of enterprises operating during the economic crisis, but this information is also valuable in such a volatile and unpredictable market as is currently in existence. In a sense, it can be said that the information obtained is “pure” information, which is free from actions aimed at improving an enterprise’s financial performance. The best example of such actions aimed at improving an enterprise’s image is the situation when provisions that are not strictly necessary are either set up or dissolved<sup>8</sup>. The second level concerns the management of operating profit. When determining the advantages and disadvantages of operating profit, one should first of all point out that the category of EBITDA is less susceptible to accounting manipulation of non-cash accruals of costs, provisions and write-offs. However, if an enterprise is affected by financial difficulties, its current assets may be illiquid and short-term liabilities may require immediate settlement. In such a situation, the flows of funds are not representative of cash flows. Another gap emerges between the flows of funds and cash flows in the event of high revenue growth<sup>9</sup>. Therefore, free cash flows determined in the third part will add to operating profit. The third element of the SME value management system applies to cash management. This part is related to the cash flow statement. This is the most complex part of the value management system. Cash flows are an integral element of the modern management of economic entities. They are so important that their characteristics, monitoring, reporting, analysis and prediction are the subject of many scientific studies, practical research as well as legal and environmental regulations, both in Poland and around the world<sup>10</sup>. The implementation of a value management system in SMEs is justified by a number of benefits for the owners<sup>11</sup>:

- creating value for owners is conducive to attracting investors,
- value is the best measure of an enterprise’s operations,
- the value management system prevents the emergence of a “value gap” allowing a hostile takeover,
- it acts as a managerial control system,
- focus on value for owners provides value to all stakeholder groups.

The simplifications for SMEs, in compliance with the accounting law, concern: the exemption from the audit and announcement of annual financial statements, the possibility of preparing financial statements in a simplified form, the exemption from the obligation to draw up a cash flow statement and a statement of changes in equity, the possibility of not establishing assets and provisions for deferred income tax. We should remember, however, about the special role of financial reporting in the information system. On the other hand, due to the fact that small enterprises use simplified accounting, the scope of information available for management purposes is significantly reduced. The far-reaching process of simplifying financial statements of SMEs is not advantageous to the management of the value of an enterprise. Source literature points to the information opacity of SMEs: information is not announced on a regular basis, neither are contracts with suppliers and customers. Accounting data of enterprises are not subject to standard financial control.

---

<sup>8</sup> Cf. E. Maćkowiak, Model przekształconego sprawozdania finansowego jako nadrzędzie zarządzania wartością finansową małych, średnich i dużych przedsiębiorstwach – głos w dyskusji [w] Finansowe uwarunkowania rozwoju organizacji gospodarczych, eds. M.Postała, J. Turyna, Wydawnictwo Uniwersytetu Warszawskiego, Wydział Zarządzania, Warszawa 2015, pp.56-57;

<sup>9</sup> Cf. R. Patterson, Kompendium terminów z zakresu rachunkowości po polsku i angielsku, Warszawa 2015, p.619;

<sup>10</sup> Por. E. Sniezek, Sprawozdawczość przepływów pieniężnych, krytyczna ocena i propozycja modelu, Wydawnictwo Uniwersytetu Łódzkiego, Łódź 2008, s.93;

<sup>11</sup> Por. J. Kuczowic, Kategorie wartości biznesu w zarządzaniu małym przedsiębiorstwem, Zeszyty Naukowe Uniwersytetu Szczecińskiego, Rynki Finansowe, Ubezpieczenia nr 79, Szczecin 2015, s. 268-269;

The changes introduced by the legislator significantly limited the scope of information that micro-entities are obliged to disclose. Despite the simplifications introduced, these entities continue to keep accounting books within the general tax framework and are required to prepare financial statements within the deadlines set for all entities. The changes introduced by the legislator also had other consequences<sup>12</sup>:

- the need to change/update accounting software,
- the need to prepare additional reports that do not contain simplifications for external users, for example, and which are prepared for banks, factoring companies or applications for EU funds,
- no possibility of using simplified reports for the purposes of financial analysis,
- the necessity to group synthetic accounts in order to transfer data to financial statements,
- the necessity to make changes to the chart of accounts and accounting policy.

#### **4. CONCLUSION**

Enterprise value management should be perceived as a system the goal of which is to maximize value, meaning the need to maximize capitals while generating the largest possible cash flows. On the other hand, enterprise value management requires the adoption of the criteria for evaluating the effectiveness of solutions and the identification of all factors that may affect the growth in an enterprise's value. The concept of value management in a small and medium-sized entity should focus on three elements:

- the proper definition of value carriers,
- the selection of appropriate measures to assess value,
- the analysis of the benefits obtained from various forms of economic ventures undertaken by an enterprise,
- the inclusion of all parties interested in the functioning of an enterprise.

These elements and the nature of small and medium-sized entities caused that these factors were taken into account in the value management system for small and medium-sized entities. Therefore, the system accounts for capital employed and free cash flows. Due to the need to apply the evaluation criteria, current assets, current liabilities, working capital and interim financial results were introduced. A multidimensional value management system in a small and medium-sized enterprise can be considered as:

- an analytical and financial tool for managers,
- an investment decision making tool for owners,
- a economic decision making tool for stakeholders.

#### **LITERATURE:**

1. R. Borowiecki, A. Jaki, J. Kaczmarek, *Metody i procedury wyceny przedsiębiorstw i ich majątku*, wyd. PSB, Kraków 1997,
2. Dudycz T. *Zarządzanie wartością przedsiębiorstwa*, PWE Warszawa 2005,
3. M. Dylewski (red.), *Finanse małych i średnich firm. Innowacje, decyzje, procesy*, CeDeWu, Warszawa 2016,
4. A. Gondek, *Wartość, jako kategoria łącząca teorie wzrostu gospodarczego z teoriami przedsiębiorstw w: Zeszyty Naukowe Uniwersytetu Szczecińskiego nr 855, Finanse Rynki Finansowe, Ubezpieczenia No. 74, Vol. 2, Szczecin 2015,*

---

<sup>12</sup> Cf. G. Voss, *Uproszczenia w sprawozdawczości finansowej w mikro i małych przedsiębiorstwach*, *Finanse, Rynki Finansowe, Ubezpieczenia No. 5/2016 (83), Part 2, Szczecin 2016, p. 160;*

5. W. Janik, A. Paździor, Zarządzanie finansowe w przedsiębiorstwie, Politechnika Lubelska, Lublin 2011,
6. J. Kuczowic, Kategorie wartości biznesu w zarządzaniu małym przedsiębiorstwem, Zeszyty Naukowe Uniwersytetu Szczecińskiego, Rynki Finansowe, Ubezpieczenia nr 79, Szczecin 2015,
7. E. Maćkowiak, Model przekształconego sprawozdania finansowego jako nadrzędzie zarządzania wartością finansową małych, średnich i dużych przedsiębiorstwach – głos w dyskusji [w] Finansowe uwarunkowania rozwoju organizacji gospodarczych, eds. M.Postała, J. Turyna, Wydawnictwo Uniwersytetu Warszawskiego, Wydział Zarządzania, Warszawa 2015,
8. M. Matejun, Zarządzanie małą i średnią firmą w teorii i w ćwiczeniach, Difin Warszawa 2012,
9. R. Patterson, Kompendium terminów z zakresu rachunkowości po polsku i angielsku, Warszawa 2015,
10. Raport o stanie małych i średnich przedsiębiorstw 2017,  
[https://webcache.googleusercontent.com/search?q=cache:SDwwhXd2C9wJ:https://www.parp.gov.pl/images/PARP\\_publications/pdf/raport%2520o%2520stanie%2520sektora%2520msp%2520w%2520polsce\\_2017.pdf+%&cd=6&hl=pl&ct=clnk&gl=pl&client=firefox-b](https://webcache.googleusercontent.com/search?q=cache:SDwwhXd2C9wJ:https://www.parp.gov.pl/images/PARP_publications/pdf/raport%2520o%2520stanie%2520sektora%2520msp%2520w%2520polsce_2017.pdf+%&cd=6&hl=pl&ct=clnk&gl=pl&client=firefox-b)
11. E. Sniezek, Sprawozdawczość przepływów pieniężnych, krytyczna ocena i propozycja modelu, Wydawnictwo Uniwersytetu Łódzkiego, Łódź 2008,
12. G. Voss, Uproszczenia w sprawozdawczości finansowej w mikro i małych przedsiębiorstwach, Finanse, Rynki Finansowe, Ubezpieczenia No. 5/2016 (83), Part 2, Szczecin 2016;

## HAPPINESS AS A RESILIENCE RESOURCE FOR THE SOCIAL REPRODUCTION OF HUMAN CAPITAL IN THE PRIVATE SPHERE

**Claudiu Coman**

*Transilvania University of Braşov, Romania*  
*claudiu.coman@unitbv.ro*

### **ABSTRACT**

*In a globalized world, contemporary economy and social development need to cope with complex challenges. There is a growing body of literature that recognizes the importance of resilience in today's societies. Most of these studies focus on economic, social or urban resilience, little attention being paid to relationship resilience. Globalization involves not only the spread of the capitalist and neoliberal ideologies, but also the individualization and reflexivization of the private life. In a public space in which competitive, transactional and instrumental relationships are becoming the norm, in the private sphere, the opposite phenomenon emerges, by growing cooperation, happiness, and emotional bonding. By studying relationships from the private sphere, one could gain a more nuanced understanding of how resilience works, so that it could be better mobilized as a resource for the reproduction of human capital. As main analysis materials, we used the results of a longitudinal psychological explicative research on the human development theme, conducted in the American context. The results show that the strongest predictors of a subjective evaluation of life as a fulfilled one are the variables measuring the management dimensions of intimacy (specific for family, friendship and community life). We discuss implications for conceptualizing happiness as a resilience resource to be taken into account by policy making for the reproduction of human capital in modern welfare economies.*

**Keywords:** *Human capital, Intimacy, Private sphere, Resilience policy, Wellbeing*

### **1. INTRODUCTION**

In a globalized world, contemporary economy and social development need to cope with complex challenges. There is a growing body of literature that recognizes the importance of resilience in today's societies. The concept of resilience has been defined differently in various disciplines (MacKinnon & Driscoll Derickson, 2013, p. 256): (1) physics – "the ability to store energy and deflect elasticity under a load without breaking or being deformed; (2) engineering – "the persistence of relationships within a system; the ability of systems to absorb change and still persist"; (3) ecology - "the capacity to tolerate disturbance without collapsing into a qualitatively different state"; (4) geography – "the ability of communities to withstand external shocks to their social infrastructure"; (5) urban and regional development – "the ability of a region to recover successfully from shocks to its economy"; (6) psychology – "the capacity for successful adaptation and functioning despite high risk, stress or trauma". Presently, scholars (Southwick et al., 2014) agree that this complex construct may be defined differently in the context of individuals, families, organizations, societies, and cultures and that it may be enhanced on various levels (individual, family, community, culture). On the one hand, the use of resilience term in social sciences academic research is predominantly related to ecology and psychology, in 1950s being mainly interpreted through a systemic and functionalistic perspective by focusing on systems' adaptability and capability to handle disruptions and variations (Woods, 2017). Later on, geographers proposed the concept of regional economic resilience (Martin & Sunley, 2015) to connect resilience with its economic effects. On the other hand, in the 1970s, the psychology research literature nuanced the concept of resilience and defined it as a resource for responding to different everyday life adversities (Fletcher & Sarkar, 2013).

Later on, psychologists introduce the concepts of family resilience (Walsh, 2015) and child resilience (Goldstein & Brooks, 2013) and showed both the importance of early family relationships (Cicchetti & Cohen, 2015) and of developing resources across the life span for successful aging (Greve & Staudinger, 2015). Hence psychologists (Jordan, 2013) proposed the concept of relational resilience, while in the economic field, it has been accepted that resilience can be conceptualised as having relational dimensions, such as communication, cooperation, and integration (Wieland & Marcus Wallenburg, 2013). Nowadays social scientists have started to use the concept of resilience as a new form of governance (Welsh, 2014) in a postmodern (Chandler, 2014) neoliberal world (Hall & Lamont, 2013) and to highlight the importance of community resilience (Berkes & Ross, 2013). In this direction, Aldrich and Meyer (2014) pleads for using the concept of social capital to understand social resilience. However, MacKinnon and Driscoll Derickson (2013, p. 253) criticises the concept of community resilience and concludes that "the ecological concept of resilience is conservative when applied to social relations" and "resilience is externally defined by state agencies and expert knowledge". This means that there is need to surpass the functionalistic and top-down approach when applying the concept to understand human relations. As a solution, the cited authors suggested the introduction of the concept of resourcefulness as an alternative approach.

### **1.1. Relations from the private sphere as a resilience resource**

In sociology, according to late modern theoreticians, in contemporary period, the intimacy has entered into a reflexive and emergent transformation of "pure relations" (Rezeanu, 2016b; Beck and Beck-Gernsheim, 1995; Giddens, 1992), relationship's "democratization" germs appear, which produce new intimacy management difficulty. Specific to late modernity, "pure relationships" have as a sole purpose mutual satisfaction of both partners and it ends when this cannot be obtained anymore (Giddens, 1992). Confronting the risk of breaking the relationship, partners must make efforts to maintain reflexive intimacy, to commit to building a common biography, on the confession and intimate opening basis. In the same time, "pure relationship" permits the development of a self-reflexive project, as the communicational practice of the intimacy contributes to the self-awareness of the partners. So, these kind of relationships demand a permanent search of self-development, improvement and satisfaction (Beck and Beck-Gernsheim, 1995). In the difficulty category of couples' intimacy management in late modernity enters the imperative of the "romantic love" (Giddens, 1992), according to which love is socially constructed as a hidden meaning of happiness. More precisely, partners' expectations to be happy being increased, rises the risk for the marriage or the relationship to disappoint, which leads to high divorce rates or to informal breakup. Therefore, marriage ideal for life loses intensity, as the individuals begin relationships knowing that they can come out of it when satisfaction is no longer obtained. Still, love continues to be socially constructed as the ingredient of happiness, no matter if the relationship is formally consumed within marriage or informally outside of it. Despite the idealization of love in late modernization, the individualization and the opening up imperative make it even more difficult to realize it. "Individualization" demands the person's freedom from collective identity traditional (religion, caste, neighborhood, country, family), which can lead to isolation and alienation, encouraging the refugee into intimacy and the idealization of permanent and "romantic love", as an answer to a world in permanent change, full of uncertainty and risks (Beck and Beck-Gernsheim, 1995). The desirable image of contemporary love is the search for emotional coherence, acceptance, and the legitimacy and pursue of self-knowing through mirroring in the other. However, when each partner wants to build its own biography, one can become an obstacle in the other's way to development, and difficulty can appear in building a common biography from other two individual biographies. Moreover, the individualization puts pressure on the individuals and permanently asks the opening for the privacy's handling, for the communication, the dialog,

confession or exposure in front of the other. This “purgative culture” of love enforces that any new situation and any individual change to be analyzed, interpreted and discussed within the relationship. So, confession isn’t made in the presence of an outside expert (priest or therapist), but is consumed in private. This pressure of exposure, the authors considers, may create conflicting situations that the partners cannot always have the competency to resolve it. Giddens (1992) admits that “pure relations” are just an ideal model as their realization in the heterosexual dyad is difficult because of various reasons. Firstly, the author considers that men and women are socio-psychologically different, because of the different primary socialization. Secondly, each partner enters the relationship with a past, with an individual biography, which must be analyzed, deconstructed and harmonized through future plans that will suit the other’s biography. Thirdly, each partner enters the relationship with a sort amount of autonomy, which if minimized or exacerbated, if no individual barriers are established, the satisfaction disappears and “pure relationship” cannot be realized. Fourthly, in the reflexive modernity, trust has no more exterior fundamentals, but has to be made through emotional opening towards the other and face the risk to be vulnerable. Fifthly, in “pure relationship”, the traditional binding liberates sexuality, so that the episodes outside marriage must be negotiated and interpreted within the intimacy, often these new sexual autonomy prescriptions come to loggerheads with the traditional networks. In other words, in late modernity, managing intimacy assumes reflexivity over differences and balancing the will for autonomy with the communion one. In recent Romanian literature, the preoccupations of contemporary intimacy’s theorization have been on and off. In this sense, Coman (2013) proposes, through a philosophical and essayistic approach, a phenomenology of love as an alternative to “Marx illusion”, to historical materialism in which the existence determines the consciousness. In conceptualization of love, the author starts from the premise that, trying to find rational reasons to justify the existence of love, we forget that love has “reality beyond any reason of it to be”. Love concept, without having as an exclusive referential any relationship whatsoever with a person, it is defined by the author as an orientation of the character which determines the way of reporting of a person to the world entirely, not only to an individual object of love. On the one hand, the author stands that the judgment makes the connection between two concepts - love and cognition - that would mean that the dissolution of a term involves the inconsistency of judgment, the abeyance of it. On the other hand, the author states that at the base of love stands a desire and faithfulness in something, in someone. In this way, the desired object can be known only through the identification of the person who wants the very object. This way, the cognition appears as the result of love and not as a purpose of it, love existing through itself, having a reality that the person involved cannot avoid. The author concludes that the self doesn’t need the other because is impatient and needs to become patient, all the contrary, the demarche of looking and living the love may cause huge flusters and pain. In what concerns experiencing love, Coman (2013) makes a self-ethnographic exercise and assumes that there is an ordinary life and an ordinary reality, but unique moments appear too, in which the judgment being suspended, nothing of what the self knows has value anymore; love being perceived subjectively as a relationship between dream and death. According to the author, this relationship is experimented this way: there is a moment, in which the self is immortal, in which knows everything and in the same times knows nothing, in which knows not through thinking, but through living in union with the other. In the author’s words, in this way, you discover yourself, and finally realize certainty, but cannot maintain there; it is the moment you start to rethink, to ask yourself questions, and knowing very clearly that the world is changing, that the individuals are changing, you try to preserve the moment, the immortality, through vows; this way you try to preserve the moment, to live it again and again forever. The conclusion of the essay is that by trying of the self to unite with the other through love doesn’t start from the logical conviction that someone was destined soul pair would exist, but all the contrary it is generated by the idea that the other, the

only one, is a point of seizing an activity, of an intern faculty of the individual, love resulting because the self cannot avoid this imperative. Contrary to the previous interpretive framework, this paper proposes another approach to happiness and intimacy, by framing them as resources for producing and reproducing economic relations of production.

### **1.2. The material dialectics frameworks**

There are scholars showing that, the globalization of capitalism and market economy brought changes at the level of intimacy life which became more instrumental and rationalized (Swader & Obelene, 2015; Swader, 2012). Others have evidenced that the the cognitive dissonance between the traditional model of family life and the reflexive intimacy of late capitalism manifest as follows: in a public space in which competitive, transactional and instrumental relationships are becoming the norm, in the private sphere, the opposite phenomenon emerges, through a growth in cooperation, happiness, and emotional bonding (Rezeanu, 2016a) which could be better evidenced by focusing on the material dimensions of domestic space (Rezeanu, 2018). The previous cited author explains that, due to the pressure coming from the spread of the capitalist and neoliberal ideologies, couples find refuge in the domestic space where they also struggle to solve the challenges of individualization and reflexivization brought by the late modernity. However, these scholars have only focused on the influence of economic globalization on the intimacy sphere and did not emphasized weather the transformations of intimacy from the private sphere could impact the changes brought by the economic globalization. Hence, this paper is framed within the material dialectics paradigm, assuming the private sphere of life has the capacity to reproduce the economic relations of production, and that relationships from the private life could empower the workforce.

## **2. MATERIALS AND METOD**

We conducted a secondary analysis of a longitudinal study, namely the Harvard Study of Adult Development (1937 - present). The study was initiated in 1937 by Arlie Bock and Clark Heath, continued in 1953 by Charles MacArthur, in 1972 by George Vaillant, and in 2003 by Robert Waldinger. The study followed for 75 years two groups of participants in order to identify the subjective wellbeing factors and those of the intimacy's quality: (1) 268 male students during their second year of Harvard University, age of 19 and surveyed for the period of 1934-1944 (Grant Study); (2) 456 boy with ages between 11 and 16, living in the suburbs of the Boston city surveyed for the period of 1940-1945 (Glueck Study). The picking of the data was done with the help of the survey (applied once every two years at the respondents' domicile), health evaluation sheet (applied once every 5 years) and of the life history type interviews (made once every 10 years). There were measured variables such as: (a) personality type, (b) apperception level; (c) mental health, (d) intelligence level, (e) general health, (f) stress adaptability, (g) school sociability, (h) school performance, (i) length and sleep quality, (j) the consume of damaging substances (Tabaco, alcohol, drugs), (k) participation in associations or clubs, (l) home atmosphere, (m) military stage or war experience, (m) close relations quality, (n) financial success etc. The obtained information from the respondents were rounded by the data given by the parents, legal tutors or spouses, so for each respondent were obtained social historic information that stretches for four generations. In present, it is worked for this study to be extended at the descendants of the initial participants' level, counting over 2000 children of the initial participants (The Harvard Second Generation study).

## **3. ANALYSIS AND INTERPRETATION OF RESULTS**

Even though people have difficulties in order to give a clear answer to the classic question regarding the general purpose of life, in ordinary life these have the tendency to invoke the fulfillment of some particular desires in order to describe their tactics for the making a fulfilled



life. Often in the social construction of the life purpose or the tactics for a fulfilled life, they merge, in different combinations, themes like the financial situation, social reputation, life without worries, power and knowledge. Among these, generally, one is considered more important than the other in what concerns the perception of it's own contribution in order to reach happiness. Conventionally, people assume granted that the usual tactics to reach happiness are related to hard work and perseverance to attain a social success. Oppositely, the longitudinal study shows that the most important ingredient in order to attain happiness is related to the quality of the relationships. Asked at the beginning of the investigation, of their general purpose in life, 80% from the young respondents of the longitudinal study invoked the desire to become rich, and 50% to become famous. The same respondents, asked 75 years later, declared that the recipe of a fulfilled life consists, not in fame and money, but in cultivation of a satisfying relationship with the family, friends and community (Waldinger, 2015). In detail, the study has three main results: (1) Close quality relationships are the most important predictor for a fulfilled life (the ones who are the most socially connected with the family, friends and community are happier, healthier and live longer than the ones who are less socially connected; and oppositely, the ones who felt alone during their life declare in the last part of it to be less happy and less healthy; fulfilled life is predicted not by the quantity of the relationships or undertaking a formal marriage, but by the quality of close relationships; loneliness is manifested despite large number of friends; formal commitment of marriage it is not the guarantee of happiness as it doesn't imply granted absence of the conflicts or the presence of affection, the divorce being incompatible with happiness; (2) happy couple's relationship is the most important predictor for a healthy life (subjective satisfaction over close relationships manifested at the age of 50 predicts the presence at the age of 80 of a healthy state evaluated objectively as being good; healthy condition which even then when is shaky its not compatible with happiness in conditions of satisfaction towards the relationship with the partner; and the association between an unhappy relationship and a unhealthy condition generates unhappiness); (3) Relationships based on security and trust is the most important predictor for a well functioning over a long time for the brain and memory (the ones who are in a relationship based on mistrust and insecurity manifests in an early stage dysfunction of the memory than the ones that are in relationships with someone who they can rely on). All in all, the results of the longitudinal study emphasize that men, no matter the way they start in life (be privileged like Harvard students, be deprived like the works from the Boston), of the way in which they looked at life at the beginning, by the position in the social structure, they become influenced, in what concerns health, hence the intimacy's management. Implicitly, the study suggests that as the satisfaction towards close relationships grew, so the life satisfaction degree grew. The study also discloses that, in the respondent's vision, happiness and life satisfaction are not obligatory associated with the absence of the family discussions or with the tendency to hold no matter what the formal commitment of marriage and avoid the divorce. The main conclusion of the research is that the strongest predictors of the subjective evaluation of life as a happy life are the variables that measure intimacy's dimension (couple's understanding and fulfilled and consistent social life). We consider that a future research should answer to questions like: (1) in what degree the intimacy from the private sphere is determinate so much for social life of partners, as for the quality of the relationship's life and (2) in what way the satisfaction over life depends of the social construct of the private sphere. On one hand, in order to avoid speculations or possible causal circularity, we recommend the introduction into a future design of the relationship between love and happiness, an intermediary dimension, expressly the perception over the private sphere. On the other hand, even though the love and happiness concepts can't be measured directly, by virtue of the epistemological relativism, the researcher can pertain to grades, levels, intensities of these in such way to generate new categories of answers such: "happier", "more loved", "more loving".

Such an approach could permit the analysis of the relationship between the variables that approximates subjective happiness, subjective love, subjective satisfaction of life and subjective wellbeing. More precisely, this operationalization might answer to dilemmas such: (1) what is the grade in which happiness associates with love, (2) to what degree life satisfaction approximates happiness or with what other set of more indicators can be used, (3) if the private sphere influences the couple's relationship or if rather the couple's relationship influences the perception over the private sphere, (4) if the age generates implicitly an image more favorable over what it was or if it's just about a desirable social image which is associated with getting old. Since in this analytical intercession we started from the premise that the reality of the couple's life is a social construct, in contradiction with the approach from the longitudinal study, we appreciate that a future research shouldn't focus on the recording of the objective data (like health condition reflected in the medical records of the partners), but on the way in which the objective aspects are reflected in the subjective perceptions of both partners in different moments of their relationship. Also, we point out that a significant challenge for the future intercessions of research from the Romanian context would be the projection and implementation of longitudinal researches over the theme between intimacy and private sphere.

#### 4. CONSLUDING REMARKS

The present paper argues for for conceptualizing happiness as a resilience resource to be taken into account by policy making for the reproduction of human capital in modern welfare economies. Its results could guide future studies to offering nuances explanations over the way in which the private sphere of the couple's intimacy, of romantic love or sociability in general could influence life satisfaction and wellbeing to (re)produce the economic relations of production and empower the workforce. By studying relationships from the private sphere, one could gain a more nuanced understanding of how resilience works, so that it could be better mobilized as a resource for the reproduction of human capital.

#### LITERATURE:

1. Aldrich, D. P., & Meyer, M. A. (2015). Social capital and community resilience. *American Behavioral Scientist*, 59(2), 254-269.
2. Beck, U. & Beck-Gernsheim, E. (1995). *The normal chaos of love*. Cambridge: Polity Press.
3. Berkes, F., & Ross, H. (2013). Community resilience: toward an integrated approach. *Society & Natural Resources*, 26(1), 5-20.
4. Chandler, D. (2014). Beyond neoliberalism: resilience, the new art of governing complexity. *Resilience*, 2(1), 47-63.
5. Coman, C. (2013). *Marx Illusion. Sociological essays about mindsets*. Viena: Osterreichisch-Rumanischer Akademischer Verein.
6. Fletcher, D., & Sarkar, M. (2013). Psychological resilience: A review and critique of definitions, concepts, and theory. *European Psychologist*, 18(1), 12-23.
7. Giddens, A. (1992). *The transformations of intimacy: Sexuality, Love and Eroticism in Modern Societies*. Cambridge: Polity Press.
8. Goldstein, S. & Brooks, R. (2013). *Handbook of Resilience in Children*. Boston, MA: Springer.
9. Greve, W., & Staudinger, U. M. (2015). Resilience in later adulthood and old age: Resources and potentials for successful aging. In D. Cicchetti & D. J. Cohen. (Eds.), *Developmental Psychopathology: Volume Three: Risk, Disorder, and Adaptation* (2nd edition) (p. 796-840). Hoboken, New Jersey: John Wiley & Sons.
10. Hall, P. A., & Lamont, M. (Eds.). (2013). *Social resilience in the neoliberal era*. Cambridge University Press.

11. Jordan, J. V. (2013). Relational resilience in girls. In S. Goldstein & R. Brooks, (Eds.). *Handbook of resilience in children* (pp. 73-86). Springer, Boston, MA.
12. Luthar, S. S. (2015). Resilience in development: A synthesis of research across five decades. In D. Cicchetti & D. J. Cohen. (eds.), *Developmental Psychopathology: Volume Three: Risk, Disorder, and Adaptation* (2nd edition) (p. 739-795). Hoboken, New Jersey: John Wiley & Sons.
13. MacKinnon, D., & Derickson, K. D. (2013). From resilience to resourcefulness: A critique of resilience policy and activism. *Progress in Human Geography*, 37(2), 253-270.
14. Martin, R., & Sunley, P. (2015). On the notion of regional economic resilience: conceptualization and explanation. *Journal of Economic Geography*, 15(1), 1-42.
15. Rezeanu, C.-I. (2016a). *Couple living space in the metropolitan area of Braşov* (unpublished doctoral thesis). Retrieved 15.11.2018 from: <https://drive.google.com/file/d/0B8QmaaRFXpKVW8wVDNxTmg0RIE/view>.
16. Rezeanu, C.-I. (2016b). Reflexive Transformation of Intimacy in Late Modernity Theories: Some Critiques and Conceptual Alternatives. *Postmodern Openings*, 7(1), 35-54.
17. Rezeanu, C.-I. (2018). Social Construal Maps to Study Territories within Home Space. In V. Manolachi, C. M. Rus, & S. Rusnac (Eds.), *Proceedings Volume 3rd Central & Eastern European LUMEN International Conference - New Approaches in Social and Humanistic Sciences* (p. 404-416). Iaşi: LUMEN Publishing House.
18. Southwick, S. M., Bonanno, G. A., Masten, A. S., Panter-Brick, C., & Yehuda, R. (2014). Resilience definitions, theory, and challenges: interdisciplinary perspectives. *European journal of psychotraumatology*, 5(1), 25338.
19. Swader, C. S. (2012). *The capitalist personality: Face-to-face sociality and economic change in the post-communist world*. New York: Routledge.
20. Swader, C. S. & Obelene, V. (2015). Post-Soviet Intimacies: An Introduction. *Sexuality & Culture*, 19(2), 245-255.
21. Waldinger, R. (2015). *What makes a good life? Lessons from the longest study on happiness*. Retrieved 15.11.2018 from: [www.ted.com/talks/robert\\_waldinger\\_what\\_makes\\_a\\_good\\_life\\_lessons\\_from\\_the\\_longest\\_study\\_on\\_happiness](http://www.ted.com/talks/robert_waldinger_what_makes_a_good_life_lessons_from_the_longest_study_on_happiness).
22. Walsh, F. (2015). *Strengthening family resilience* (3rd edition). New York, London: Guilford Publications.
23. Welsh, M. (2014). Resilience and responsibility: governing uncertainty in a complex world. *The Geographical Journal*, 180(1), 15-26.
24. Wieland, A., & Marcus Wallenburg, C. (2013). The influence of relational competencies on supply chain resilience: a relational view. *International Journal of Physical Distribution & Logistics Management*, 43(4), 300-320.
25. Woods, D. D. (2017). Essential characteristics of resilience. In D. Woods, E. Hollnagel, & N. Leveson (eds.), *Resilience engineering* (p. 33-46). London: CRC Press.

## PRICE COMPETITION AND ENTRY UNDER CORPORATE SOCIAL RESPONSIBILITY PRODUCT DIFFERENTIATION

**Michał Wojna**

*Department of Economics, Kozminski University in Warsaw, Poland  
michwoj@kozminski.edu.pl*

**Domenico Buccella**

*Department of Economics, Kozminski University in Warsaw, Poland  
buccella@kozminski.edu.pl*

### **ABSTRACT**

*Do firms adopt social concerns and advocate social progress for the sake of philanthropy, or is there also a strategic rationale for social engagement? In a monopoly with threat of market entry, this paper analyzes the potential competitor entry decisions in the presence of strategic use of Corporate Social Responsibility (CSR) by the incumbent and, therefore, the potential anticompetitive effect of CSR. We consider profit sharing (with stakeholders, i.e. a firm's donation) as a form of CSR that is valued by consumers and affects their purchase decisions. An incumbent adopting CSR creates product market differentiation and thus weakens the price competition among firms. On the other hand, weaker price competition can encourage potential entrants. To show this result, we develop a three-stage entry game. In the first stage, the incumbent monopolist determines the level of CSR. In the second stage, the potential rival decides whether to enter. In the case of entry, Bertrand competition among the two rivals takes place in the product market in the third stage. Solving the game using backward induction to obtain subgame perfect Nash equilibria, we find that natural barriers to entry (sunk costs) and CSR activity are strategic substitutes, and either of two equilibria can arise: accommodation with a market segmentation or blockaded entry of the potential competitor, depending on the cost structure of firms. This result is in line with the observation that CSR activity can lead to higher market concentration, market segmentation, or both.*

**Keywords:** *CSR, Product differentiation, Market entry, Market segmentation, Monopoly, Duopoly, Price competition*

### **1. INTRODUCTION**

Strategic motive of Corporate Social Responsibility (CSR) has received much attention from scholars and practitioners recently. The basic notion is that profit-maximizing firms can engage in such activities in order to maintain or improve their market position. Firms can have various reasons to implement strategic CSR. When consumers are conscious of and responsive to responsible and sustainable practices of a firm, CSR can play an important role in a firm's product differentiation strategy. This kind of vertical differentiation gives another dimension to the product quality and can be viewed as a complement to the increasing technical sophistication or innovative features of the product. Surveys show that consumers are increasingly informed about CSR practices, and this knowledge has an effect on their purchasing behavior. According to the Harris Interactive study, 82% percent of American consumers in 2012 were aware of companies and brands pursuing CSR activities. Nielsen annual surveys (ACNielsen, 2015) reveal that the percentage of consumers that are willing to pay extra for products committed to positive social and environmental impact is constantly increasing, reaching 66% in 2015. Consumers' positive response to CSR practices was confirmed across countries and branches. For example, according to Eurobarometer survey (Commission of the European Communities, 1997), 70% of European consumers was prepared

to pay at least 10% premium for fair-trade bananas. Enhanced willingness to pay for products related to CSR was found in coffee fair trade (Loureiro and Lotade, 2005), hygienic eco-label product markets (Bjorner et al. 2004), and the seafood market (Del Giudice, 2018) among others. While a majority of studies indicate that CSR is a win-win situation for brands and consumers, relatively less attention has been paid to examining the strategic effects of CSR investments in markets with imperfect competition. There are two established approaches to modeling strategic CSR in the literature. The first one assumes that firms adopting CSR incorporate consumers' or stakeholders' surplus into its objective function and make its decision public as a commitment tool in the entry game (Goering 2010, Kopel and Brand 2012). The second strand of literature attributes the firm's involvement in CSR to the fact that consumers tend to reward socially responsible firms willing to pay a premium for socially responsible products (Manasakis et al., 2013, Banerjee and Wathieu, 2017). We argue that vertical differentiation related to CSR can reduce price competition and thus encourage entry in contestable markets. In this paper, we develop a simple model of entry in a Dixit-Spence setting (Dixit, 1980; Spence, 1977), with an incumbent monopolist, one potential entrant and price competition à la Bertrand. In our framework, only the incumbent firm can engage in socially responsible activities as it has an experience-based advantage – it knows consumers response to CSR. In general, the implementation and maintenance of CSR activities entail costs; one way of expressing this notion is to assume that firms with social concern spend some share of its profits on socially responsible and sustainable practices. Accordingly, we introduce the sharing parameter, which is the incumbent's control variable. This parameter measures social engagement of the incumbent and, at the same time, defines the extent of the product's vertical differentiation. Under specific assumptions on consumer tastes for ethical and sustainable products, this allows the incumbent to attract customers with higher willingness to pay and gives rise to market segmentation. Our study contributes to the literature on strategic CSR by showing the interplay between entry costs and the level of incumbents' engagement in CSR activity. Our main finding suggests that, in the absence of fixed-entry cost accommodation strategy is a unique subgame perfect equilibrium. In contrast, when the act of entering the market entails strictly positive sunk costs, the incumbent does not engage in CSR, thereby posing a threat of fierce price competition in homogenous good market, and as a result, the blockaded entry case arises. Our paper relates to the literature on vertical product differentiation and market entry. The studies closest to the model considered here are Shaked and Sutton (1982) and Donnenfeld and Weber (1992). These authors show that equilibrium product quality differentiation critically depends on the entry costs. If these costs are low, entry is accommodated with a high quality choice of incumbent. By contrast, when entry costs are high, the incumbent chooses quality similar to the expected entrant's quality, and as a result, blockaded entry equilibrium arises. Our paper is also related to the work of Graf and Wirl (2014), which considers CSR as a mode of vertical product differentiation in the optimal market entry response problem.

## 2. THE MODEL AND THE RESULT

There is a continuum of consumer types  $\theta$  distributed uniformly over  $(0, 1)$ . Sets of consumers take form of intervals  $[\theta_x, \theta_y]$  with a measure  $\theta_y - \theta_x$ . Utility (indirect) function takes the form:

$$U(\theta, \alpha, p_1) = V(\theta, \alpha) - p_1 \quad (1)$$

if type  $\theta$  buys from the incumbent, and

$$U(\theta, \alpha, p_2) = V(\alpha, 0) - p_2 \quad (2)$$

if she buys from the entrant. The parameter  $\alpha$  stands for sharing parameter, and  $p_1$  and  $p_2$  denote prices of incumbent and entrant, respectively. Each consumer has reserved zero utility if she doesn't buy and otherwise has perfectly inelastic unit demand. The function  $V$  has a property of increasing differences:

$$\text{for } (\theta_1, \alpha_1) > (\theta_2, \alpha_2): V(\theta_1, \alpha_1) - V(\theta_1, \alpha_2) > V(\theta_2, \alpha_1) - V(\theta_2, \alpha_2), \quad (3)$$

moreover:

$$V(\theta, 0) \equiv \theta, V(0, 0) = 0 \quad (4)$$

For smooth functions, condition (2) is equivalent to:

$$\frac{\partial^2 V}{\partial \theta \partial \alpha} > 0 \quad (5)$$

This means that an increase of the sharing parameter brings more value for "higher" types than for "lower" ones. In the context of CSR, this can be interpreted as a complementary relation between socially responsible attributes of product and other quality characteristics in consumers' utility functions. The first step in our analysis is a description of the division of market between incumbent and entrant for arbitrary  $\alpha$  and price vector if the entry takes place. Notice that, if type  $\theta_i$  buys, all higher types also buy:

$$\max\{V(\theta_i, \alpha) - p_1, V(\theta_i, 0) - p_2\} \geq 0 \Rightarrow \max\{V(\theta_j, \alpha) - p_1, V(\theta_j, 0) - p_2\} \geq 0$$

for  $\theta_j > \theta_i$  (from single crossing) (6)

We now show the proper self-selection of consumers (according to the preference order) into two separate sets (intervals). Consider type  $T_1$  that is indifferent to buying from the entrant or incumbent and some type  $\theta_i$  that strictly prefers buying from the incumbent for a given price vector. Then, the following two conditions must hold:

$$V(T_1, \alpha) - p_1 = V(T_1, 0) - p_2 \quad (7)$$

$$V(\theta_i, \alpha) - p_1 > V(\theta_i, 0) - p_2 \quad (8)$$

Summing up these conditions, we get:

$$V(T_1, \alpha) - V(T_1, 0) < V(\theta_i, \alpha) - V(\theta_i, 0) \quad (9)$$

which means that  $\theta_i > T_1$  under assumption of increasing differences. On the other hand, it stems directly from increasing differences property that, if  $\theta_i > T_1$ , then type  $\theta_i$  will buy from the incumbent. One can apply an analogous sort of reasoning for types that buy from the entrant. The market is divided between firms as is depicted on Figure 1 below.

Figure 1: Division of the market between incumbent and entrant in absence of entry costs

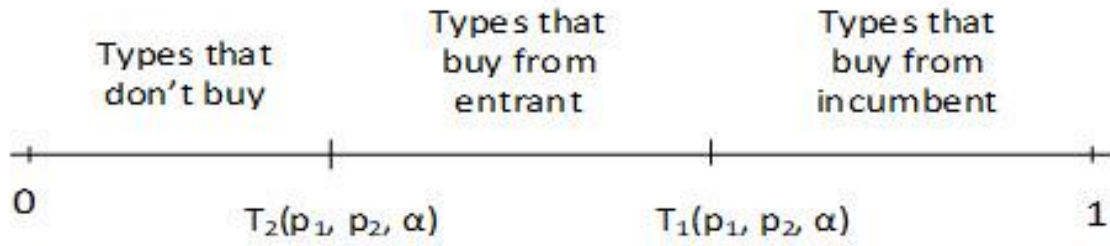

Source: Authors' calculations

Type  $T_1$  is indifferent to buying from the incumbent or entrant; accordingly, the following condition must hold:

$$V(T_1, \alpha) - p_1 = T_1 - p_2 \quad (10)$$

Type  $T_2$  is indifferent to buying from the entrant or not buying at all

$$T_2 = p_2 \quad (11)$$

Now, we can write down the objective function for the incumbent under the assumption of zero marginal and fixed costs (positive marginal costs are not necessary in our setting but would complicate the analysis):

$$\pi_1 = (1 - \alpha)p_1(1 - T_1), \quad (12)$$

and for the entrant

$$\pi_2 = p_2(T_1 - T_2) \quad (13)$$

Our entry game considers three stages: In the first stage, the incumbent monopolist chooses the value of the sharing parameter and announces it. The potential entrant does not possess the knowledge of CSR activity specific to the branch and consumer tastes, and its sharing parameter is set to zero. Thus, only the incumbent has the option to differentiate (vertically) the product in the market. In the second stage, the potential competitor decides whether to enter the market. In the third stage, if entry occurs, firms compete in prices for a determined level of product differentiation. For modelling convenience, we propose a specific form of  $V(\dots)$  to find  $T_1$  and  $T_2$  explicitly:

$$V(\theta, \varphi) = \theta(1 + \alpha) \quad (14)$$

Substituting (10) and (11) into the objective functions of the incumbent and entrant, and taking the specified form of  $V$  in (14), we get both (net) profits as functions of the choice variables:

$$\pi_1 = (1 - \alpha)p_1 \left( 1 - \frac{p_1 - p_2}{\alpha} \right) \quad (15)$$

$$\pi_2 = p_2 \left( \frac{p_1 - p_2}{\alpha} - p_2 \right) \quad (16)$$

We solve the game by backward induction, starting from the last stage decisions. Applying the FOCs with respect to prices, we find reaction functions for both the incumbent and entrant respectively, for the arbitrary value of the sharing parameter:

$$p_1 = \frac{1}{2}\alpha + \frac{1}{2}p_2 \quad (17)$$

$$p_2 = \frac{1}{2} \frac{p_1}{\alpha+1} \quad (18)$$

Note that, for zero value of the sharing parameter, the standard Bertrand duopoly case with homogenous products and strategic complements in prices arises. Solving the system of (17) and (18), we find equilibrium prices in the second stage of the game.

$$p_1^*(\alpha) = \frac{2\alpha(\alpha+1)}{3+4\alpha} \quad (19)$$

$$p_2^*(\alpha) = \frac{\alpha}{3+4\alpha} \quad (20)$$

Let us discuss potential strategies of the incumbent in the first stage under the assumption of the absence of entry costs. Strategic deterrence in the absence of fixed costs would come down to setting the sharing parameters as equate  $T_1$  and  $T_2$ . Inserting equilibrium prices (19) and (20) into (10) and (11) yields:

$$T_1 = \frac{2\alpha+1}{3+4\alpha} \quad (21)$$

$$T_2 = \frac{\alpha}{3+4\alpha} \quad (22)$$

However, straightforward calculation show that  $T_1 > T_2$  for all  $\alpha \in \langle 0; 1 \rangle$ , which is depicted in Figure 2 below.

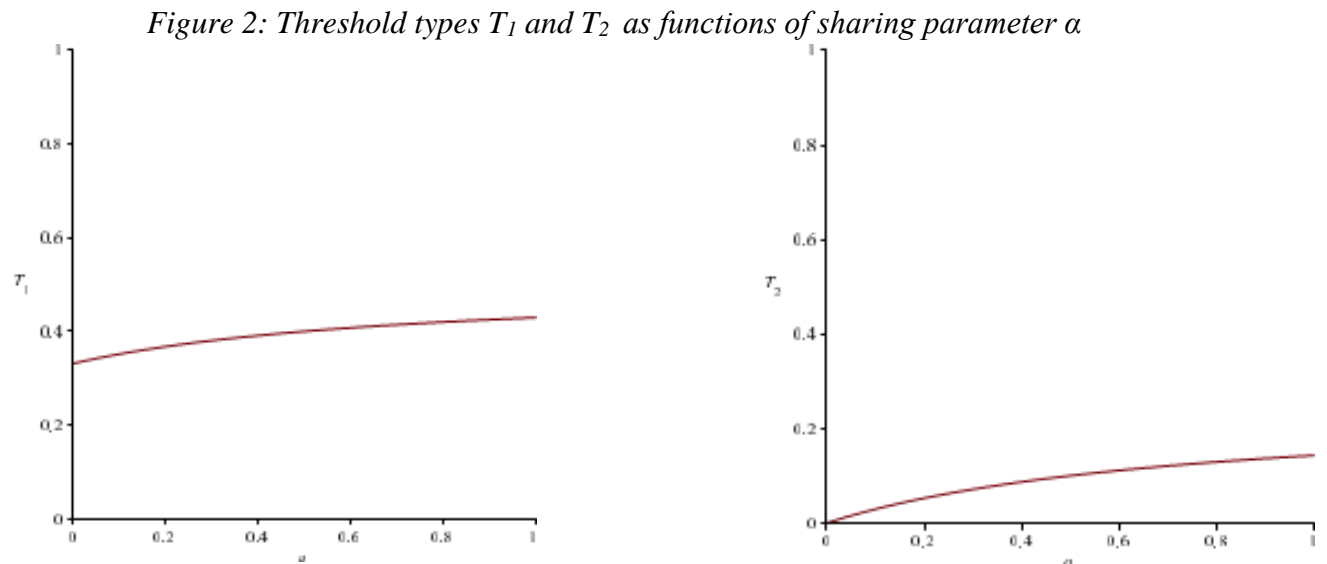

*Source: Authors' calculations.*



In the accommodation strategy, the incumbent maximizes his (net) profit, setting the optimal value of the sharing parameter in the first stage. Inserting (19), (20), (21), and (22) into (15) and (16), we get equilibrium profits as a function of the sharing parameter:

$$\pi_1 = \frac{4\alpha(1-\alpha)(\alpha+1)^2}{(3+4\alpha)^2} \quad (23)$$

$$\pi_2 = \frac{\alpha(\alpha+1)}{(3+4\alpha)^2} \quad (24)$$

Maximizing  $\pi_1$  with respect to  $\alpha$  yields  $\alpha^* = 0,465$ , and the corresponding equilibrium profits of incumbent and entrant are:

$$\pi_1^* = 0,0904 \quad (26)$$

$$\pi_2^* = 0,0288 \quad (27)$$

Now let us consider strictly positive entry costs. In this scenario, we first examine the decisions of the incumbent monopolist who is not threatened by entry. Rewriting the condition (10) for the monopolist case and arbitrary vector of choice variables  $(\alpha, p_1)$ , we get:

$$V(T_1, \alpha) - p_1 = 0. \quad (28)$$

Thus, for a specified  $V(\dots)$  function (14), the monopolist's objective function is given by:

$$\pi_1 = (1 - \alpha)p_1 \left(1 - \frac{p_1}{\alpha}\right) \quad (29)$$

The monopolist maximizes its objective function with respect to choice variables  $\alpha$  and  $p_1$ . The corresponding system of FOCs is :

$$\frac{\partial \pi_1(\alpha, p_1)}{\partial \alpha} = 0 \quad (30)$$

$$\frac{\partial \pi_1(\alpha, p_1)}{\partial p_1} = 0, \quad (31)$$

and for  $\alpha \in \langle 0; 1 \rangle$  and  $p_1 \geq 0$  is solved for stationary values:  $\alpha^* = 0$  and  $p_1^* = 0,5$ . This means that the monopolist does not engage in CSR at all and consequently potential entry with strictly positive entry costs is blockaded (in this case, products are homogenous and potential Bertrand competition drives prices down to zero in the second-stage subgame equilibrium).

**Result 1:** In the absence of fixed entry costs, the only subgame perfect equilibrium is as follows: the incumbent sets a positive value of sharing parameters and thus accommodates entry. As a result, market segmentation arises with the incumbent targeting consumers with higher willingness to pay. In the presence of strictly positive entry costs, the only subgame perfect equilibrium is thus: the incumbent sets zero sharing parameters, and the entry is thus blockaded.

### 3. CONCLUSION

In this paper, we examined some strategical considerations of CSR activity in contestable markets. We build a two-stage game in which the incumbent at first determines the level of CSR activity, thus differentiating its product and price competition, which takes place in the

second stage. We have found that strategic use of CSR critically depends on the presence of market entry barriers. For strictly positive entry costs, adopting CSR is a dominated strategy, since vertical differentiation encourages entry by reducing post-entry price competition. Accordingly, it is shown that the incumbent can block entry by driving its CSR engagement down to zero, which is a subgame perfect equilibrium in this case. We demonstrate that, under the absence of entry costs, the incumbent accommodates the entrant by choosing strictly positive value of sharing parameter.

#### **LITERATURE:**

1. Banerjee, S., Wathieu, L. (2017). Corporate social responsibility and product quality: Complements or substitutes? *International Journal of Research in Marketing* 34, (pp. 734-745)
2. Baron, D. P. (2009). A Positive Theory of Moral Management, Social Pressure, and Corporate Social Performance. *Journal of Economics and Management Strategy* 18 (1), (pp. 7–43).
3. Bjorner, T. B., Hansen, L. G., and Russell, C. S. (2004). Environmental labeling and consumers' choice – An empirical analysis of the effect of the Nordic Swan. *Journal of Environmental Economics and Management* 47, (pp. 411–24).
4. Del Giudice, T., Stranieri, S., Caracciolo, F., Ricci, E. C., Cembalo, L., Banterle, A., Cicia, G. (2018). Corporate Social Responsibility certifications influence consumer preferences and seafood market price. *Journal of Cleaner Production*, 178, (pp. 526-533).
5. Dixit, A. (1980). The role of investment in entry-deterrence. *The Economic Journal* 90(357), (pp. 95-106).
6. Donnerfeld, S. & Weber, S. (1992). Vertical Product Differentiation with Entry, *International Journal of Industrial Organisation*, 10, (pp. 449-472).
7. Commission of the European Communities (1997). The Common Agricultural Policy: Attitudes of EU Consumers to Fair Trade Bananas. Eurobarometer Special Report No. 116.
8. Goering, G. E. (2007). The Strategic Use of Managerial Incentives in a Non-Profit Firm Mixed Duopoly. *Managerial and Decision Economics* 28(2), (pp. 83–91).
9. Graf, C. & Wirl, F. (2014). Corporate social responsibility: a strategic and profitable response to entry? *Journal of Business Economics* 84(7), (pp. 917– 927).
10. Harris Interactive (2012). Harris Poll Reputation Quotient. Retrieved on December 15, 2012, from <http://www.harrisinteractive.com/Products/ReputationQuotient.aspx>.
11. Kopel, M. & B. Brand (2012). Socially Responsible Firms and Endogeneous Choice of Strategic Incentives. *Economic Modelling* 29(3), (pp. 982–989).
12. Loureiro, M. L. & Lotade, J. (2005). Do fair trade and eco-labels in coffee wake up the consumer conscience? *Ecological Economics*, 53, (pp. 129-138)
13. Manasakis, C., Mitrokostas, E., Petrakis, E. (2013). Certification of corporate social responsibility activities in oligopolistic markets. *Canadian Journal of Economics* 46, (pp. 282–309).
14. Nielsen (2015), The sustainability imperative. Report, October 2015
15. Planer-Friedrich, L., Sahm, M. (2016). Why firms should care for all consumers, BERG Working Paper Series, No. 116, ISBN 978-3-943153-35-4.
16. Shaked, A. & Sutton, J. (1982). Relaxing Price Competition through Product Differentiation, *Review of Economic Studies*, 49, (pp. 3-13).
17. Spence, A. M. (1977). Entry, capacity, investment and oligopolistic pricing. *The Bell Journal of Economics* 8(2), (pp. 534-544).

## ANALYSIS OF THE EFFECTS OF APPLYING THE NEW IFRS 16 LEASES ON THE FINANCIAL STATEMENTS

**Mirjana Hladika**

*Faculty of Economics and Business, University of Zagreb, Croatia  
mhladika@efzg.hr*

**Ivana Valenta**

*Faculty of Economics and Business, University of Zagreb, Croatia  
ivalenta@efzg.hr*

### ABSTRACT

*Current model of lease accounting pursuant to IAS 17 Leases requires the classification of leases on operating and finance leases. There is a distinction in accounting treatment of each type of lease. Significant differences are observed in financial statements of lessee. According to IAS 17, if there is a contract about the operating lease the lessor recognize the asset in lease in its financial statement of financial position, while the lessee recognizes only the costs of rent in its income statement (but not the assets in lease and financial liabilities related to lease during lease period). If there is a contract about the finance lease, the lessee recognizes the assets in lease and financial liabilities related to lease in its financial statement of financial position. Many of financial statements users have highlighted disadvantages of accounting model for operating lease, primarily because there are not evident financial liabilities during whole lease period in the statement of financial position of a lessee. Therefore, the financial statements of a lessee are not representing faithfully its financial position as well lessees' indebtedness is not appropriate presented. In order to enhance the accounting model for leases, in January 2016 the International Accounting Standards Board (IASB) issued a new accounting standard IFRS 16 Leases that will become effective for annual reporting periods beginning on or after 1 January 2019 (IFRS 16 will replace IAS 17). New IFRS 16 implement unique accounting model for all leases in financial statements of a lessee. Changes in lease accounting are focused on better and comprehensive presentation of accounting information related to leases in financial statements. The implementation of new accounting model will influence on the coverage of information presented in financial statements, and consequently on financial ratios of a lessee. The goal of this paper is to investigate and analyse key effects which the implementation of IFRS 16 and new accounting model for lease will have on financial statements. The main consequences and effects of implementation of IFRS 16 are analyzed through the case study.*

**Keywords:** *Assessment of effects, Financial statements, IAS 17, IFRS 16, Lease accounting*

### 1. INTRODUCTION

Leasing is a very important source of funding of entities from all sectors and for different types of assets (machinery, airplanes, cars and other means of transport, real estate, laptops and others). Leasing enables companies to access and use property and equipment without incurring large cash outflows at the beginning (PWC, 2016, pp. 2). In order to highlight the significance and lease volume, it is important to present that in the EU-28 and EFTA countries, equipment rental companies and other companies providing rental services generate a total rental turnover of more than EUR 24.5 billion in 2016 (ERA, 2018, pp. 2). Furthermore, according to report of Leaseurope (2018), the portfolio of leased assets (leasing and automotive rental industries) grew by 5.3% and reached EUR 802.2 billion at the end of 2017. The reason for popularity of leasing is contained in its specific accounting treatment. Current lease accounting is carried out according to the requirements presented in IAS 17 Leases.

IAS 17 requires the classification of leases on operating or finance leases. Lessee recognizes finance lease in its statement of financial position as the assets in lease and financial liabilities related to lease. On the other hand, operating lease is recognized in lessees' income statement just as an expense (costs of rent) (an off-balance sheet lease). The consequence of such accounting treatment of operating lease in lessees' financial statements is insufficient transparency of information about assets and liabilities arise from operating lease. Users of financial statements are not able to properly evaluate financial position and financial performance as well the indebtedness of companies (lessees) with a significant amount of active contracts in operating leases. Consequently, such approach to the accounting treatment of operating leases by lessees' caused a significant number of requirements from different financial statement users (investors, financial analysts, creditors and others) for changes of those accounting model. Since 2006, development of a new single approach to lease accounting was one of a major convergence project between the International Accounting Standards Board (IASB) and the Financial Accounting Standards Board (FASB). The goal of this project was to develop new accounting model for lease that will ensure presentation of all assets and liabilities arising from a lease in statement of financial position (or balance sheet). The new lease accounting model is presented in January 2016 in IFRS 16 Leases, and this standard will become effective for annual reporting periods beginning on or after 1 January 2019 (IFRS 16 will replace IAS 17). This standard will lead to the capitalisation of the majority of current operating leases by the lessees. The goal of this paper is to investigate and analyse key effects which the implementation of new IFRS 16 and new accounting model for lease will have on lessees' financial statements and on its financial ratios. The analysis of determined effects which the application of new accounting model for leases will have on lessees' financial statements and its financial ratios is provide through the case study.

## **2. LITERATURE REVIEW**

### **2.1. Lease accounting model under IAS 17 and IFRS 16**

Under IAS 17, the leases are classified as finance or operating lease. The classification of leases is based "on the extent to which risks and rewards incidental to ownership of a leased asset lie with the lessor or the lessee" (Bakran, Gulin, Milčić, 2016, IAS 17). The lease is classified as a finance lease if the lease transfers substantially all the risks and rewards incidental to ownership from lessor to lessee (Bakran, Gulin, Milčić, 2016, IAS 17). Finance lease is reported in a lessees' statement of financial position. Lessees recognize finance leases as assets and liabilities in their statement of financial position at amounts equal to the fair value of the leased property or, if lower, the present value of the minimum lease payments, each determined at the inception of the lease (Bakran, Gulin, Milčić, 2016, IAS 17). Since lessees recognize assets and liabilities from finance lease in their statement of financial position, they also recognize depreciation expense for assets in finance lease as well as finance expense for each accounting period. On the other hand, lessors shall recognise assets held under a finance lease in their statement of financial position and present them as a receivable at an amount equal to the net investment in the lease (Bakran, Gulin, Milčić, 2016, IAS 17). The lease is classified as an operating lease if it does not transfer substantially all the risks and rewards incidental to ownership from lessor to lessee (Bakran, Gulin, Milčić, 2016, IAS 17). Operating leases are not recognized in lessees' statement of financial position. Asset which is the subject of operating lease is recognized in lessors' statements of financial position according to the nature of the asset. Depreciation expense is presented in lessors' income statement. Lessees recognize only lease payments from operating lease as an expense on a straight-line basis over the lease term (Bakran, Gulin, Milčić, 2016, IAS 17). Lessee presents the information about the assets and liabilities from operating lease in notes to the financial statements or as an off-balance sheet items.

Current accounting model for operating leases has been criticised by different users of financial statements, practitioners and academics. The main criticism is focused on the lack of transparency of financial statements of companies with significant amounts of assets held in operating leases, because the assets and liabilities arising from operating lease are not presented in lessees' statement of financial position. Typical examples of sectors with high volumes of operating leases that are not currently recognised in the statement of financial position are retail, airlines, hotels and telecommunications (Morales-Diaz and Zamora-Ramirez, 2018). In those circumstances, financial statement users are not able to properly evaluate a financial position of lessee as well to calculate its indebtedness. In order to eliminate disadvantages of current accounting model for operating lease, IASB and FASB started lease accounting joint project and they developed a new single accounting model for leases. IASB issued the new IFRS 16 in January 2016 in which the new accounting model for leases has been introduced. The most significant change under IFRS 16 in comparison to IAS 17 is the introduction of the new lease accounting model to be applied by lessees. Lease accounting model (under IFRS 16) eliminates the classification of leases as either finance or operating lease for a lessee, and it requires that all leases are treated similarly to finance lease under IAS 17 (IFRS Foundation, 2016). IFRS 16 requires lessees to recognise nearly all leases on the statement of financial position which will reflect their right to use an asset for a period of time and the associated liability for payments (PWC, 2016, pp. 2). Accordingly, at the commencement date, a lessee shall recognize a right-of-use asset and a lease liability on its statement of financial position (IFRS 16, 2017). Exemptions from the application of this model to the lessee are possible for short-term leases (less than 12 months) and for leases for which the underlying asset is of low value (IFRS 16, 2017). In the income statement, the lessee will recognize the interest cost and the amortisation of the leased asset. The lease accounting model for lessors set up in IFRS 16 remains the same model as it was set up under IAS 17. Lessors continue to classify leases either as finance or operating lease. As the new IFRS 16 introduces new lease accounting model that changes only the accounting treatment of operating lease for the lessees, the most significant influence of this model will be on the statement of financial position of lessee with significant amount of operating leases that are not presented on actual statement of financial position. The recognition of operating lease in lessees' statement of financial position will have an impact on its financial position and key financial ratios. The higher amount of operating lease means the greater impact on financial position of a lessee.

## **2.2. Review of previous researches on lease capitalisation**

There are many researches that have been conducted in order to assess the impact of changes in lease accounting on companies' financial position and financial performance, and consequently on its financial ratios. Most of these researches are focused on accounting for operating leases by lessees, and on the impact of the operating lease capitalisation on lessees' financial statements. Beattie, Edwards and Goodacre (1998) have analysed the impact of operating lease capitalisation on key accounting ratios on a random sample of 300 listed industrial and commercial UK companies. Research includes the period from 1990 to 1994. The results showed that lease capitalisation will have a significant impact on financial statements ("on average, the unrecorded long-term liability represented 39% of reported long-term debt, while the unrecorded asset represented 6% of total assets"). Results indicated that lease capitalisation will have a significant impact on selected financial ratios – profit margin, return on assets, asset turnover and measures of gearing. Furthermore, the lease capitalisation will have an influence on the ranking of companies which will significantly change. Bennett and Bradbury (2003) analyzed the expected impact of the capitalisation of operating leases on financial statements and key financial ratios on a sample of 38 companies listed on the New Zealand Stock Exchange in 1995.

Research results showed that operating lease capitalisation has a significant impact on financial position of a company. In their study they found an average increase in total assets for 8.8% and 22.9% for total liabilities, and a decrease for 3% in equity. Results showed that leverage will significantly increase, while profitability and liquidity are expected to decrease. Mulford and Gram (2007) have examined the expected impact of operating lease capitalisation on a sample of 19 US companies from retail industry. The results of this study showed the increase of total assets for 14.6 % and total liabilities for 26.4%, so the impact of lease capitalisation on companies' financial position is significant. They also find significant increase in EBITDA whilst a reduction in income from continuing operations and decrease of earnings per share (EPS). Furthermore, they find that the profitability measures (return on assets – ROA and return on equity – ROE) are decreasing in those circumstances. Finally, results showed an increase in the operating cash flows and in free cash flows. Durocher (2008) has investigated the impact of operating lease capitalisation on the statement of financial position and key financial ratios on a sample of 100 largest Canadian quoted companies (from all sectors) for years 2002 and 2003. The results showed a significant increase in total assets and total liabilities. As a consequence, there is evident significant decrease in current ratio, and significant increases in the debt-to-asset ratio. Also, in this study is stated that lease capitalisation should have a significant profitability effects (ROA, ROE and EPS) only in certain industry segments like merchandising and lodging, oil and gas and financial services. Singh (2012) has analysed the expected impact of operating lease capitalisation on financial statements and key financial ratios on a sample of 234 restaurants and retail companies for the period from 2006 to 2008. Consistent with previous studies, he concluded that operating lease capitalisation will have a significant impact on financial statements and the coverage of presented information as well on key financial ratios. The influence of new model of lease accounting will affect both sectors, although retail sector shall be affected to a greater extent than the restaurant sector. Wong and Joshi (2015) investigated the effects of lease capitalisation on financial statements and financial ratios on a sample of 107 Australian companies (from several sectors) listed on the Australian stock Exchange in the year of 2010. The results of their research have indicated the significant impact on the statement of financial position (increase in total assets and total liabilities, and decrease in total equity). Furthermore, results showed that the financial ratios such as debt to equity (D/E) ratio, debt to assets (D/A) ratio and return on asset (ROA) will change significantly under lease capitalisation, while the change in return on equity (ROE) is insignificant. Bohušová (2015) has investigated the impact of operating lease capitalisation on companies' financial statements and financial analysis ratios on a sample of non-financial companies listed on the Prague Stock Exchange. In this research was used reporting information on operating lease in accordance with IAS 17. The results of this research have showed a negative impact of operating lease capitalisation on financial analysis ratios (decreasing of return on assets, increase of indebtedness, and increase of debt to equity ratio). Morales-Diaz and Zamora-Ramirez (2018) conducted a research on a sample of 646 quoted European companies (from a variety of sectors) included in the STOXX Total Market. They found that the capitalisation of operating leases will have a significant impact on statement of financial position (total assets and total liabilities will increase significantly), leverage (leverage will increase significantly) and solvency ratios of European quoted companies. The intensity of these impacts depends on the sector in which certain entity operates. The results of their research showed that the most affected sectors are the retail, transportation, hotels and software and services sectors. The results of all above mentioned researches showed a significant impact of operating lease capitalisation of financial position and key financial ratios of lessees'.

### 3. ANALYSIS OF THE EFFECTS OF OPERATING LEASE CAPITALISATION ON LESSEES' FINANCIAL STATEMENTS – A CASE STUDY

In this part of the paper, are explained the consequences of application of new lease standard IFRS 16 Leases on the financial statements of the lessee. Under IAS 17 Leases company (lessee) accounted all the lease payments from the operating lease directly in profit in loss as rental expenses. Under IFRS 16 company (lessee) needs to recognize the right-of-use asset and the lease liability in its statement of financial position. As example is taken the company A, which rents office space whose fair value is 1.450.000 HRK, and its period of use is 25 years. Company A and company X signed rental contract for a period of 5 years. The annual rent is 60.000 HRK and it is paid at the beginning of the year. For initial measurement of the lease liability, lessee shall measure the lease liability at the present value of the lease payments that are not paid at that date. The lease payments shall be discounted using the interest rate implicit in the lease, but if that rate cannot be determined, the lessee shall use the lessee's incremental borrowing rate, and that is the rate at which lessee would be able to get the new borrowings for acquisition of the same asset with similar terms. As in this study is not defined the implicit interest rate in the contract, it is used the incremental borrowing rate which can medium sized company determine from the banks. The incremental borrowing rate is specific to the lessee, it is rate that reflects the credit-worthiness of the company, it is specific to the term of the arrangement, the amount of the funds borrowed or the security and the quality of the underlying asset and the economic environment. A lessee is required to identify a discount rate for all leases, and it should be realistic discount rate because many lessee financial ratios will be sensitive to the discount rate. Using a higher discount rate will reduce reported liabilities and the leverage will be lower, asset turnover and current ratio will be higher because total asset and the lease liability will be lower. For this case of calculating the lease liability it is used incremental borrowing rate of 4%, for which it was assumed that presents some average interest rate in current economic environment for medium sized companies in Croatia. The right-of-use asset is equal to the lease liability at the commencement date, plus lessee's initial direct costs which are in this case zero. At the company A, the right to use office space is amortised on a straight line basis, for the period of the agreement. The right to use the asset and the liability are measured at the discounted value of the payments generated by the agreement, amounting to 267.109 HRK. As it can be seen in Table 1, at the beginning of 2019 agreement was settled, and the first rate was paid.

*Table 1: Calculation of principal repayment and interest*

Date	Paid amount	Discount rate	Discount factor	Present value of lease payments	Principal repayment	Interest	Unsettled liability
1.1.2019.							267.109
1.1.2019.	60.000	4%	0,9615	57.692	49.316	10.684	217.793
1.1.2020.	60.000	4%	0,9246	55.473	51.288	8.712	166.505
1.1.2021.	60.000	4%	0,8890	53.340	53.340	6.660	113.165
1.1.2022.	60.000	4%	0,8548	51.288	55.473	4.527	57.692
1.1.2023.	60.000	4%	0,8219	49.316	57.692	2.308	0
<b>Total</b>	<b>300.000</b>			<b>267.109</b>	<b>267.109</b>	<b>32.891</b>	

*Source: Authors*

The right of use asset is amortised on a straight line basis, for the period of the agreement, whereas the annual amortisation amounts 53.422 HRK (267.109 HRK / 5 years). Each lease payment of 60.000 HRK is split between principal repayment and interest. Interest is calculated as unsettled liability at the end of previous year multiple discount rate.

Principal repayment is calculated as the difference between annual rent and interest. At the end of the year should be calculated unsettled liability which is calculated as unsettled liability from previous year minus principal repayment from current year. In Table 2 is shown the comparative analysis of the effects of the application of each of accounting standard about leases (IAS 17 and IFRS 16) on the value of company's assets and liabilities.

*Table 2: Comparative analysis of effects on assets and liabilities*

Date	IAS 17			IFRS 16		
	Assets	Liabilities	Off-balance sheet item	Assets	Liabilities	Off-balance sheet item
31.12.2019.	0	0	240.000	213.687	217.793	0
31.12.2020.	0	0	180.000	160.265	166.505	0
31.12.2021.	0	0	120.000	106.844	113.165	0
31.12.2022.	0	0	60.000	53.422	57.692	0
31.12.2023.	0	0	0	0	0	0

*Source: Authors*

As it can be seen from the Table 2, when the IAS 17 is applied, the lessee presents the operating lease as off-balance sheet item in its financial statements. New lease standard IFRS 16 will improve transparency because all leases have to be included in statement of financial position. In this case it can be seen that liabilities at the end of the first year of agreement amount 217.793 HRK, while assets amount 213.687 HRK. In table 3 is shown the comparative analysis of the effects of the application of lease standards (IAS 17 and IFRS 16) on company's profit or loss.

*Table 3: Comparative analysis of effects on profit or loss*

Item	2019.		2020.		2021.		2022.		2023.	
	IAS 17	IFRS 16	IAS 17	IFRS 16	IAS 17	IFRS 16	IAS 17	IFRS 16	IAS 17	IFRS 16
Rental expenses	60.000	0	60.000		60.000		60.000		60.000	
Amortisation costs		53.422		53.422		53.422		53.422		53.422
Financing costs		10.684		8.712		6.660		4.527		2.308
Total Costs	60.000	64.106	60.000	62.134	60.000	60.082	60.000	57.948	60.000	55.729
Profit/loss before tax	income - 60.000	income - 64.106	income - 60.000	income - 62.134	income - 60.000	income - 60.082	income - 60.000	income - 57.948	income - 60.000	income - 55.729
Difference	4.106		2.134		82		-2.052		-4.271	
Tax deductions	739		384		15		-369		-769	

*Source: Authors*

As it can be seen from Table 3, according to IAS 17, operating lease amounts 60.000 HRK, and it was classified as rental expenses. Impact on profit and loss before tax was the same every year and lease reduced company's income every year for the same amount. This 60.000 HRK present annual rent that was paid at the beginning of the every year of the lease period. Effects on company's profit or loss that will be caused by the implementation of new lease standard IFRS 16 are shown also in Table 3. Lessees will have to present the amortisation costs (in this case the amortisation costs amount 53.422 HRK) and the interest for each year which was calculated in Table 1.



That is because the total costs in each year of lease agreement would not be the same – in the first years total costs will be higher and they will decrease through years. So it can be concluded that profit and loss before tax will be lower in the first years of implementation of IFRS 16 in comparison to IAS 17, and in the last years it will be vice versa, but in total the effects on profit or loss will be levelled. In Table 4 are analyzed the effects of implementation of the new lease standard IFRS 16 on the company's equity.

*Table 4: Effects of new IFRS 16 on equity*

Date	IAS 17	IFRS 16	Effects of applying IFRS 16 on equity
31.12.2019.	60.000	64.106	-4.106
31.12.2020.	60.000	62.134	-2.134
31.12.2021.	60.000	60.082	-82
31.12.2022.	60.000	57.948	2.052
31.12.2023.	60.000	55.729	4.271
Total	300.000	300.000	0

*Source: Authors*

In Table 4 are compared total costs under IAS 17 and IFRS 16 and their impact on equity. As it can be seen, total effect on companies' profit or loss that arises from the application of IAS 17 and IFRS 16 is the same and it amounts 300.000 HRK, but the time of costs presentation is different. So in the first years equity will be lower by applying IFRS 16, especially in first year, but in the last year of agreement, equity will be higher by applying IFRS 16. In Table 5 is presented cash flow from operating, investing and financing activities for company A from this case.

*Table 5: Effect of new IFRS 16 on cash flows*

Item	2018.		2019.		2020.		2021.		2022.	
	IAS 17	IFRS 16	IAS 17	IFRS 16	IAS 17	IFRS 16	IAS 17	IFRS 16	IAS 17	IFRS 16
Operating activities	60.000	10.684	60.000	8.712	60.000	6.660	60.000	4.527	60.000	2.308
Investing activities										
Financing activities		49.316		51.288		53.340		55.473		57.692
Net cash flow	60.000	60.000	60.000	60.000	60.000	60.000	60.000	60.000	60.000	60.000

*Source: Authors*

As it can be seen from Table 5, net cash flow is the same under IAS 17 and IFRS 16. The difference is in the structure of net cash flow, because under IFRS 16 interest is presented under operating activities, and principal repayment is presented under financial activities. It can be concluded that implementation of new IFRS 16 will mostly improve companies transparency because leases need to be included in lessees' statement of financial position as right-of-use an asset and lease liability. This will increase amount of lessee's assets and liabilities, but also will affect on the most of financial ratios which are important for all stakeholders. New lease standard will affect on the profit and loss because in the first years of lease agreement the profit will be lower because of amortisation costs and interest, and during the lease agreement

interests are lower, so the profit will be higher. That directly effects on the equity, but in total period, there will be no effect of implementation of new standard on companies' equity. If it is looked the effect on cash flow statement (Table 5), it can be concluded that implementation of the new standard will mostly have an influence on the amount of cash flow from operating activities, which will be higher, so the financial ratios such as free cash flow will be more favourable for the company.

#### 4. CONCLUSION

The new lease standard (IFRS 16 Leases) will be mandatory for annual reporting periods beginning on or after 1 January 2019. Application of a new lease standard will fundamentally change the way the leases are accounted for and reported in financial statements for the lessee. The major change that is introduced in IFRS 16 contains the capitalisation of current operating lease for the lessee. Recognition of all leases in lessees' statement of financial position as the right-of-use asset and a lease liability contributes to the improvement of the quality and comparability of financial statements and better transparency of a company (lessee). Financial statements (statement of financial position, income statement and cash flow statement) of the lessee will undergo significant changes depending on the volume and amount of active contract of operating leases. Total assets and total liabilities will increase and that will have a significant impact on lessees' financial position. In the income statement, the lessee will recognize the interest cost and the amortisation of the leased asset. In the cash flow statement the structure and amount of cash flows from operating and financing activities will change, but total net cash flow will remain at the same level. As it was evidenced from prior researches, operating lease capitalisation will have a significant impact on the financial statements as well on financial ratios and performance metrics. The application of IFRS 16 will affect on financial ratios and performance metrics such as gearing, interest cover, current ratio, EBITDA, EBIT, operating profit, net income, return on assets, return on equity, earnings per share, operating and financing cash flows. Consequently, these changes may affect the credit rating, loan covenants and borrowing costs. Extended coverage of accounting information presented in lessees' financial statements is useful for different users of financial statements. Changes in lease accounting enables users of financial statement with the information about the amount, timing and uncertainty of cash flows that arising from a lease. Based on the research results it can be concluded that a new standard (IFRS 16) and new accounting model for leases will provide investors and other financial statement users with more precise information for assess a financial position and value the debt obligations of a company, as well to more accurately assess the risks undertaken by the company.

#### LITERATURE:

1. Bakran, D., Gulin, D., Milčić, I. (2016). *Međunarodni standardi financijskog izvještavanja; Hrvatski standardi financijskog izvještavanja*. Zagreb: Hrvatska zajednica računovođa i financijskih djelatnika.
2. Beattie, V., Edwards, K., Goodacre, A. (1998). The Impact of Constructive Operating Lease Capitalisation on Key Accounting Ratios. *Accounting and Business Research*, 28(4), pp. 233-254.
3. Bennett, B.K., Bradbury, M.E. (2003). Capitalizing Non-cancelable Operating Leases. *Journal of International Financial Management and Accounting*, 14(2), pp. 101-114.
4. Bohušová, H. (2015). Is Capitalization of Operating Lease Way to Increase of Comparability of Financial Statements Prepared in Accordance with IFRS and US GAAP?. *Acta Universitatis Agriculturae et Silviculturae Mendelianae Brunensis*, 63(2), pp. 507-514.
5. Durocher, S. (2008). Canadian Evidence on the Constructive Capitalisation of Operating Leases. *Accounting Perspectives*, 7(3), pp. 227-256.

6. ERA. (2018). *ERA Market Report 2017*. Retrieved 18.10.2018 from <https://erarental.org/en/publications/era-rental-statistics/era-market-report-2017>
7. IFRS Foundation. (2016). *IFRS 16 Leases – Project Summary and Feedback Statement*. Retrieved 21.10.2018 from [https://ifrs16org.files.wordpress.com/2016/07/ifrs\\_16\\_project-summary.pdf](https://ifrs16org.files.wordpress.com/2016/07/ifrs_16_project-summary.pdf)
8. IFRS 16 *Leases*. (2017). Retrieved 20.10.2018 from <https://eur-lex.europa.eu/legal-content/EN/TXT/PDF/?uri=CELEX:32017R1986&qid=1541882816108&from=HR>
9. Leaseurope. (2018). *Key facts and figures 2017*. Retrieved 18.10.2018 from [http://www.leaseurope.org/uploads/documents/LeaseuropeFF\\_17\\_PRINT.pdf](http://www.leaseurope.org/uploads/documents/LeaseuropeFF_17_PRINT.pdf)
10. Morales-Diaz, J., Zamora-Ramirez, C. (2018). The Impact of IFRS 16 on Key Financial Ratios: A New Methodological Approach. *Accounting in Europe*, 15(1), pp. 105-133.
11. Mulford, C., Gram, M. (2007). The Effects of Lease Capitalisation on Various Financial Measures: An Analysis of the Retail Industry. *Journal of Applied Research in Accounting and Finance*, 2(2), pp. 3-13.
12. PWC. (2016). IFRS 16: The Leases Standard is Changing – are you ready?. Retrieved 20.10.2018 from <https://www.pwc.com/gx/en/services/audit-assurance/assets/ifrs-16-new-leases.pdf>
13. Singh, A. (2012). Proposed Lease Accounting Changes: Implications for the Restaurant and Retail Industries. *Journal of Hospitality & Tourism Research*, 36(3), pp. 335-365.
14. Wong, K., Joshi, M. (2015). The Impact of Lease Capitalisation on Financial Statements and Key Ratios: Evidence from Australia. *Australasian Accounting, Business and Finance Journal*, 9(3), pp. 27-44.

## FACTORS EFFECTING MARKET ACTIVITIES THAT LEADS TO INVESTOR'S OVERCONFIDENCE: PAKISTAN STOCK EXCHANGE CASE

**Fareeha Javed Qureshi**

*Anadolu University, Graduate School of Social Sciences, Eskisehir, Turkey  
javed.faree2@gmail.com*

**Murat Ertugrul**

*Anadolu University, Faculty of Economics and Administrative Sciences, Eskisehir, Turkey  
mertugrul@anadolu.edu.tr*

### **ABSTRACT**

*The purpose of the research is to review the results of study conducted in 2008 that claim to investigate the relationship of investors' happy sentiment and overconfidence effect. Cloud coverage, temperature and temperature change, former returns, and short term loan l change rate are used as proxies for happy sentiment. Data from Pakistan stock exchange and Metrological department is collected to check the Relation. The happy sentiment index is divided into two categories: "natural environment happiness" and "investment atmosphere happiness." The results suggest that short term loan rates, Previous day turnover and previous day activities have significant low effect on investment overconfidence of investor so trading activities are affected. Natural environment factors have less impact while investment atmosphere happiness has moderately high effect on market activities of investors.*

**Keywords:** *Behavioural finance, weather effect, investors' overconfidence, market turnover, stock markets*

### **1. INTRODUCTION**

Market efficiency is a topic of debate from several decades. The argument that if all markets are efficient then why some investors can perform better in market leads to raise several questions on market efficiency. Behavioral Finance is an emerging field in theory of knowledge. Moods, behavior, sentiments and attitudes of investor are very important. The follower of inefficient market concept is trying to proof market inefficiencies by conducting researches on factors which are unique to market activities. Odean describes overconfidence as "a belief that a trader's information is more precise than it actually is" (1998, p. 1893). The paper is a type of review research and is an effort to check the claim that happy investors are overconfident as claimed by Chih-Lun Huang and Yeong-Jia Goo in their paper published in 2008. Instead of directly involving investors, the behavior change of investors is observed by keeping in mind few factors. According to some researchers the weather has effect on investor that leads him to perform overconfidently in market and thus market activities fluctuates between Bearish to bullish and Vice Versa. Brown and Cliff argue that investor sentiment "represents the expectations of market participants relative to a norm: a bullish (bearish) investor expects returns to be above (below) average, whatever 'average' may be" (2004, p. 2). Much of the existing literature on behavioral biases indicates the limited research in emerging economies in this area, the dominance of secondary data-based empirical research, the lack of empirical research on individuals (Satish and Nisha, 2014). This research is conducted on data collected from developing economy of Asia from year 2007 to 2016. Although the results are significant but shows that not very strong evidence could be gathered on such claims. Market variables such as daily close and open readings, market volume change, weather change and other climate variables are analyzed to check the accuracy of claim. However the research provokes a desire to check the relation of these unique variables on sector wise and seasonal

businesses as somewhat a moderate relationship is evident from the research which shows there are few sectors that might be fashion industry or food and cement industries where investor could be affected by these changes.

## 2. METHODOLOGY

In the light of literature reviewed, the study tries to check the affect of factors influencing overconfidence. It tests the hypothesis that overconfident investors are happy investors and overconfidence of investor could be determined by using fundamental values. Although overconfidence is behavioral phenomenon but some market variables and climate variables can be helpful to get an idea that how active investors are on that day. For happiness, two proxies "Natural Environment Happiness" and "Investment Atmosphere Happiness" is used. Natural Environment factors include the cloud coverage and temperature changes while Investment Atmosphere Happiness include the Lag of Market turnover, lag of previous day open values and short term loan rates of that day. It was assumed that if cloud coverage is low and temperature is not too high or too low beside a positive change in previous day market turnover, previous day opening readings and interbank loan offer rates, the investor will feel happy and become overconfident leads to changed values of market turnover. This study intends to evaluate the relation between investor activity level and one of the irrational investment behaviors i.e. over confidence using data from Pakistan.

Overconfidence, OC= Market Turnover (M.T.O)

Where M.T.O. = (total number of shares traded over a period / average outstanding shares at that period) ----- 1

Happiness variable (H) is divided into Investment Atmosphere Happiness (IAH) and Natural Environment Happiness (NEH)

Whereas

Natural Environment Happiness (NEH)= Cloud coverage, (CC) + Lag cloud Coverage Change , (LagCloud)

or

(NEH)= CC+LagCloud ----- 2

Data for both variables have been collected from metrological department of Pakistan from year 2007 Jan to 2016 Sep

While

Investment Atmosphere Happiness (IAH) = Former day returns change ( $\Delta R(t-1)$ ) + Former short term Loan rate ( $L(t-1)$ ) + Former Market turnover M.T.O( $t-1$ ) + Former daily Open (Open( $t-1$ )).

or

(IAH) =  $\Delta R(n-1) + (L(n-1)) + M.T.O(n-1) + (Open(n-1))$ ----- (3) Here  
 $L(t-1) = ((L2-L1)/L1)*100$ ----- (3a)

$L(t-1)$ = short term loan rate in trading day before the current day

MLR2 = Margin loan in one trading day before t - 1 day.

And  $\Delta R(t-1)$ , is defined as  $(R) = ((R2+R1)/R1) * 100$  ----- (3b)

R1= Ending value of Market Returns day before the current day R2= Opening value of Market returns day before the current day

Study defines their relationship as below

$$OC = \alpha_0 + IAH \alpha_1 + \epsilon \text{-----}(5)$$

$$OC = \alpha_0 + NEH \alpha_1 + \epsilon \text{-----}(6)$$

$$OC = \alpha_0 + IAH \alpha_1 + NEH \alpha_2 + \epsilon \text{-----}(7)$$

Ten years data of Pakistan stock market from year 2007 to 2016 is used. For weather, daily cloud coverage and average daily temperature in city where the largest stock exchange of country is located. Cloud coverage is measured in OKT having value 0 to 9. 0 is for clear sky while 9 is for sky obstructed from view. Data is collected from Metrological department on daily bases. Stock exchange works 5 days in week from Monday to Friday and also remain close on public holidays while the data of temperature and cloud coverage was on continuous daily basis, 7 days in a week. For this first the required data is filtered than Scattered Plots were created to check the outliers in data. After removing the outliers and public holiday “2268” readings/ data points are used to run the analysis. Two tailed Pearson and Spearman correlation is used to interrogate relationship among the components. Significance of relation is checked on 0.01 and 0.05 Level of Confidence. Regression analysis is used to check the affect of happiness on overconfidence. For autocorrelation Durbin Watson test is used as a diagnostic tool.

### 3. ANALYSIS AND RESULTS

*Figure 1: Daily market Turnover during years 2007-2016*

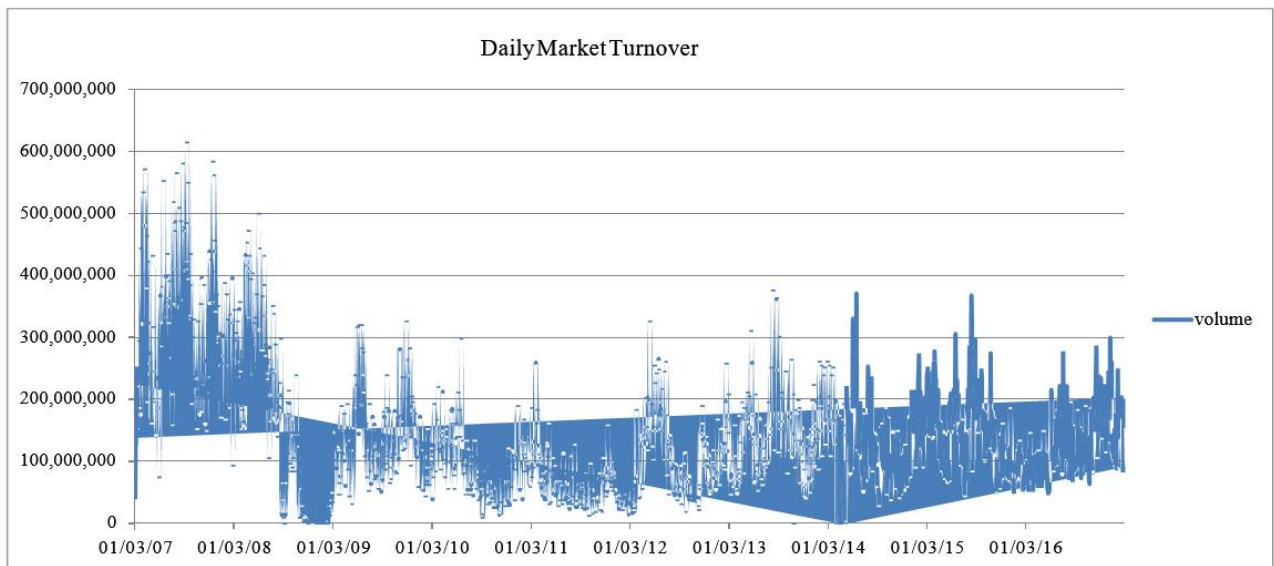

*Table following on the next page*

*Table 1: Spearman Correlation*

Correlations										
Spearman's rho		cloud coverage	Day close	Previous day change	Loan rate	Previous day open	Change of cloud coverage	Previous day temperature change	Previous day short term loan rate	Previous day Turnover
Daily Market turnover	Correlation Coefficient	-.083**	.182**	.081**	-.425**	.179**	.080**	.089**	-.427**	.806**
	Sig. (2-tailed)	.000	.000	.000	.000	.000	.000	.000	.000	0.000
	N	2286	2286	2285	2286	2285	2286	2285	2285	2285

\*. Correlation is significant at the 0.05 level (2-tailed).  
 \*\*. Correlation is significant at the 0.01 level (2-tailed).

*Table 1(a): Pearson Correlation*

Correlations									
Daily Market Turnover	cloud coverage	Day close	Previous day change	Loan rate	Previous day open	Change of cloud coverage	Previous day temperature change	Previous day short term loan rate	Previous day Turnover
Pearson Correlation	-.293*	.024	.163**	-.314**	.020	.138**	.129**	-.316**	.825**
Sig. (2-tailed)	.000	.258	.002	.000	.329	.001	.000	.000	0.000
N	2286	2286	2285	2286	2285	2286	2285	2285	2285

\*. Correlation is significant at the 0.05 level (2-tailed).  
 \*\*. Correlation is significant at the 0.01 level (2-tailed).

Table 1 shows the Spearman's correlation among variable. Although the values are not high but these are significantly correlated with each other at .01 level as for all the values P value is less than 0.05. Table 1(a) is about Pearson Correlation. As Pearson correlation is more restricted measure to check correlation so after applying the test it is examined that although Spearman Correlation is showing a significant low correlation between day close, Pearson correlation measure rejects the relationship as P value is also high i.e. > .05. so we dropped the variables Day close and Previous day open from our Model. However other variables are showing significant relation with our overconfidence proxy i.e. Daily market turnover though the relation is not so strong. When daily loan rate increases investor does not feel comfortable in investing so Daily market activity decreases as shown by the value -.314 which is significant at confidence interval .05 and .01. Regression Analysis for Daily Volume Turnover, Lag of Temperature Change, Cloud Coverage and Change of Cloud Coverage

*Table 2 Regression: Market Turnover as dependent variable  
 Variables Entered/Removed<sup>a</sup>*

Model	Variables Entered	Variables Removed	Method
1	Previous day temperature change, cloud coverage, Change of cloud coverage <sup>b</sup>	.	Enter

a. Dependent Variable: Daily Market turnover  
 b. All requested variables entered.

*Table 2(b): ANOVA<sup>a</sup>*

Model		Sum of Squares	df	Mean Square	F	Sig.
1	Regression	468150095284387650	3	156050031761462560.	120.564	.000 <sup>b</sup>
	Residual	17309161685683874000	2281	7588409331733395.		
	Total	17777311780968262000	2284			

a. Dependent Variable: Daily Market Turnover  
 b. Predictors: (Constant), Previous day temperature change, cloud coverage, Change of cloud coverage

Table 2(c) : Regression Model volume vs Natural Environment Happiness

Model Summary

Model	R	R Square	Adjusted R Square	Std. Error of the Estimate
1	.262 <sup>a</sup>	.126	.0185	87111476.47

a. Predictors: (Constant), Previous day temperature change, cloud coverage, Change of cloud coverage

Table 2(d): Coefficients<sup>a</sup>

Model	Unstandardized Coefficients		Standardized Coefficients	t	Sig.	
	B	Std. Error				Beta
1	(Constant)	120859727.538	6575235.620	98.381	.000	
	cloud coverage	-3183226.271	804604.719	-.082	-3.956	.000
	Change of cloud coverage	1845996.518	579493.073	.091	3.186	.001
	Previous day temperature change	1059450.962	566995.249	.053	1.869	.062

a. Dependent Variable: Daily Market turnover

Table 2 ,2(a), 2(b) and 2(d) are generated to check the relationship of Proxy for Happiness: Natural Environment happiness. Table 2(c) includes variable cloud coverage on that day, change of cloud coverage and previous day temperature change based upon the correlation calculated through Pearson correlation measure. However after applying the regression it is concluded that previous day temperature change has no significant effect on Market turnover, in other words, on overconfidence of investor. However Cloud coverage has weak negative but significant relation with Market turnover while change has positively weak but significant relation with daily turnover activities of investor. Table 3 :Variables Entered/Removed

Regression: Volume Vs Investment Atmosphere Happiness

Table 3 :Variables Entered/Removed<sup>a</sup>

Model	Variables Entered	Variables Removed	Method
1	Previous day Turnover, Previous day change, Previous day open, Previous day short term loan rate <sup>b</sup>		Enter

a. Dependent Variable: Daily Market turnover

b. All requested variables entered.

Table 3(a): Model Summary<sup>b</sup>

Model	R	R Square	Adjusted R Square	Std. Error of the Estimate	Durbin-Watson
1	.832 <sup>a</sup>	.692	.691	49012756.32960	2.280

a. Predictors: (Constant), Previous day Turnover, Previous day change, Previous day open, Previous day short term loan rate

b. Dependent Variable: Daily Market turnover



*Model 3(b): ANOVA<sup>a</sup>*

Model	Sum of Squares	df	Mean Square	F	Sig.
1 Regression	123001811356713 35000.000	4	307504528391783 3700.000	1280.069	.000 <sup>b</sup>
Residual	547713064529692 7700.000	2280	240225028302496 8.500		
Total	177773117809682 64000.000	2284			

*a. Dependent Variable: Daily Market turnover*

*b. Predictors: (Constant), Previous day Turnover, Previous day change, Previous day open, Previous day short term loan rate*

*Model 3 ( c ) : Coefficients<sup>a</sup>*

Model	Unstandardized Coefficients		Standardized Coefficients	T value	Sig.	
	B	Std. Error	Beta			
1	(Constant)	134832531.967 3663853.501	13190195.604 943208.238		10.222 3.884	.000 .000
	Previous day change	-1269.725	187.807	.045	-6.761	.000
	Previous day open	-7566934.180	892836.163	-.138	-8.475	.000
	Previous day short term loan rate	.754	.013	-.182	57.971	.000
	Previous day Turnover			.769		

*a. Dependent Variable: Daily Market turnover*

Table 3,3(a),3(b) and 3(c) describes the results calculated for Regression analysis of daily turnover volume and Investment Atmosphere Happiness. It includes variables Previous day change, Previous day open, previous day short term loan rate and previous day market turnover. In order to check the autocorrelation Durbin Watson test is applies which is showing value 2.280. it shows that data has almost no autocorrelation. Durbin Watson value ranges from 0-4 and value 2 shows no autocorrelation in observed values. All factors are showing P values less than .05 that tells that they have significant effect on model. The Model R value is .832 and adjusted R<sup>2</sup> value as .692 which means the model is good to explain the relationship as in general R value is between 0 to 1.

Regression (Complete Model)

Overconfidence = Investment Atmosphere Happiness + Natural Environment Happiness

*Table following on the next page*

*Table 4: Variables Entered/Removed<sup>a</sup>*

Model	Variables Entered	Variables Removed	Method
1	Previous day Turnover, Previous day open, cloud coverage, Change of cloud coverage, Previous day short term loan rate, Day session average close <sup>b</sup>		Enter

*a. Dependent Variable: Daily Market turnover*

*b. All requested variables entered.*

*c.*

*Table 4(a) Model Summary<sup>b</sup>*

Model	R	R Square	Adjusted R Square	Std. Error of the Estimate	Durbin-Watson
1	.837 <sup>a</sup>	.700	.700	48356329.81245	2.266

*a. Predictors: (Constant), Previous day Turnover, Previous day open, cloud coverage, Change of cloud coverage,*

*Previous day short term loan rate, Day session average close*

*b. Dependent Variable: Daily Market turnover*

*Table 4 (b): ANOVA<sup>a</sup>*

Model		Sum of Squares	df	Mean Square	F	Sig.
1	Regression	124505854871520 77000.000	6	2075097581192012800.	887.4 25	.000 <sup>b</sup>
	Residual	532672629381618 4800.000	2278	2338334632930722		
	Total	177773117809682 62000.000	2284			
a. Dependent Variable: Daily Market turnover						
b. Predictors: (Constant), Previous day Turnover, Previous day open, cloud coverage, Change of cloud coverage, Previous day short term loan rate, Day session average close						

*Table following on the next page*

*Table 4 ( c ): Coefficients<sup>a</sup>*

Model	Unstandardized Coefficients		Standardized Coefficients	t	Sig.
	B	Std. Error			
(Constant)	144388630.008	13366014.119		10.803	.000
cloud coverage	-2529636.895	449037.207	-.065	-5.633	.000
Day session average close	20220.209	3517.848	2.198	5.748	.000
Previous day open	-21566.596	3522.461	-2.341	-6.123	.000
Change of cloud coverage	573009.969	235912.103	.028	2.429	.015
Previous day short term loan rate	-7771796.187	881338.624	-.187	-8.818	.000
Previous day Turnover	.745	.013	.761	57.546	.000

*a. Dependent Variable: Daily Market turnover*

*4 ( d ): Residuals Statistics<sup>a</sup>*

	Minimum	Maximum	Mean	Std. Deviation	N
Predicted Value	5359620.5000	470409824.0000	138053851.8630	73832374.77762	2285
Residual	244307040.0000	226207632.0000	.00000	48292772.72499	2285
Std. Predicted Value	-1.797	4.501	.000	1.000	2285
Std. Residual	-5.052	4.678	.000	.999	2285

*a. Dependent Variable: Daily Market turnover*

Finally the tables 4, 4(a), 4(b), 4( c ) and 4 (d) show the Model statistics and analysis values. According to the table 4(a) the R value of Model is .837 and the adjusted R value is .77 which show a significant good fit at .01 and .05 level of confidence interval. Durbin Watson Value of Model is also acceptable i.e. 2.266.

#### 4. CONCLUSION

The study assumed that investors are more confident when there is good weather (Model 1) and an optimistic investment atmosphere stimulates stock trading (Model 2). The results show that when the sky is not too cloudy (negative value of coefficient) the activity of investor is high as suggested by Kumar & Nish, (2008) that investment atmosphere affects mood and mood affects stock trading. When there is a happy investment atmosphere, investors are more optimistic, able to bear higher risk, and likely to act in a way that causes overconfidence. Frequent trading causes investors to assets at higher prices. However the short term loan rates and previous day loan rates also affect the investment mood of investors, they tend to be less active and decrease trading on days having high rates. However, the significant values although showing low correlation suggest that nontechnical factors like weather, temperature or cloud coverage change are not strongly effecting investor's overconfidence in all sectors but they might have strong influence on few sectors where season has effect on business activities.

#### 5. LIMITATIONS AND FUTURE SCOPE

The study is based on single country data. Moreover the study is limited to secondary quantitative data, qualitative measures like survey, questioners and primary data cross sectional

data can increase the parsimony of research under discussion. Sector wise division of shares traded could also help to get a better understanding of results. Other irrational investor behaviors, such as overreaction and disposition effect rarely involved with investor sentiment in past studies can be subjects for further research. In addition, fear and regret could be included in future studies.

#### **LITERATURE:**

1. Bollen, J., Mao, H., & Zeng, X. (2011). *Twitter mood predicts the stock market*. Journal of computational science, 2(1), 1-8.
2. Brown, G.W., and M.T. Cliff. 2004. *Investor Sentiment and the Near-Term Stock Market*. Journal of Empirical Finance 11, no. 1: 1-27
3. Chang, S. C., Chen, S. S., Chou, R. K., & Lin, Y. H. (2008). *Weather and intraday patterns in stock returns and trading activity*. Journal of Banking & Finance, 32(9), 1754-1766.
4. Goetzmann, W. N., Kim, D., Kumar, A., & Wang, Q. (2014). *Weather-induced mood, institutional investors, and stock returns*. The Review of Financial Studies, 28(1), 73-111.
5. Huang, C. L., & Goo, Y. J. (2008). *Are happy investors likely to be overconfident?* Emerging Markets Finance and Trade, 44(4), 33-39.
6. Jacobsen, B., & Marquering, W. (2009). *Is it the weather? Response*. Journal of Banking & Finance, 33(3), 583-587.
7. Kang, S. H., Jiang, Z., Lee, Y., & Yoon, S. M. (2010). *Weather effects on the returns and volatility of the Shanghai stock market*. Physica A: Statistical Mechanics and its Applications, 389(1), 91-99.
8. Kondor, P. (2012). *The More We Know about the Fundamental, the Less We Agree on the Price*. Review of Economic Study , 1175-1207.
9. Kourtidis, D., Šević, Ž., & Chatzoglou, P. (2016). *Mood and stock returns: evidence from Greece*. Journal of Economic Studies, 43(2), 242-258.
10. Lee, W. Y., Jiang, C. X., & Indro, D. C. (2002). *Stock market volatility, excess returns, and the role of investor sentiment*. Journal of banking & Finance, 26(12), 2277-2299.
11. Levy, O., & Galili, I. (2008). *Stock purchase and the weather: Individual differences*. Journal of Economic Behavior & Organization, 67(3), 755-767.
12. Lu, J., & Chou, R. K. (2012). *Does the weather have impacts on returns and trading activities in order-driven stock markets? Evidence from China*. Journal of Empirical Finance, 19(1), 79-93.
13. Muradoglu, G., & Harvey, N. (2012). *Behavioural finance: the role of psychological factors in financial decisions*. Review of Behavioural Finance, 4(2), 68-80.
14. Symeonidis, L., Daskalakis, G., & Markellos, R. N. (2010). *Does the weather affect stock market volatility?* Finance Research Letters, 7(4), 214-223.

## HOBBY CULTURE AS A SOURCE OF ENTREPRENEURSHIP – INNOVATION AND RISK MANAGEMENT

**Niko Komljenovic**

*Faculty of Law, University of Zagreb, Croatia  
niko.komljenovich@gmail.com*

**Nenad Rancic**

*Department of Economics, Faculty of Law, University of Zagreb, Croatia  
nrancic@pravo.hr*

**Ozren Pilipovic**

*Department of Economics, Faculty of Law, University of Zagreb, Croatia  
opilipovic@pravo.hr*

### **ABSTRACT**

*For economists, leisure time is most often the period in which people consume and spending is the main aspect of free time they are studying. However, leisure is the time in which people create. In this paper the emphasis has been put on the creative potential of free time, and in this connection, the idea of hobby culture development as a catalyst for entrepreneurship. The reason lies in the complementarity of the hobby culture and entrepreneurial culture. If we distinguish between innovation and entrepreneurial risk as the two fundamental theoretic determinants of the concept of entrepreneurship, we will see that hobby activity unobtrusively solves the underlying problem of encouraging the expansion of entrepreneurial behavior. The hobby itself hides the potential for mitigating risk aversion. The reason lies in an interesting phenomenon that deserves more attention, for the purposes of this paper we call it a phenomenon of double benefits; hobbyists are often prepared to bear a serious financial loss, just to satisfy their interest. This tendency of general spending often turns into a tendency to capital spending, ie investment. The reason for this kind of behavior is hidden in the promise of double benefits. For a hobbyist, investment is not only a promise of future higher spending geared towards meeting its interests and needs, but it additionally meets the present need to deal with its hobby. There is also another effect of the hobbyist activity that contributes to the reduction of aversion to risk. A hobby in its essence is a game, the consequence of such pursuit of leisure is feelings of enthusiasm and optimism. Such is the effect of hobbies on the nature of things because the hobby is, among other things, a quest for pleasure. On the contrary, the fact is that the pessimistic social climate is one of the reasons for the insufficient development of the entrepreneurship. The active pursuit of leisure time in the form of hobbies also promotes creative behavior that creates a suitable climate for the emergence and development of innovations.*

**Keywords:** *hobby culture, entrepreneurship, innovation, risk management*

### **1. INTRODUCTION**

The question of free time and the way we spend it plays a significant role in the development of entrepreneurship. According to the way we spend it, free time can be divided into active or productive and passive or consuming (Farkaš 2014, pp 6-7). Nowadays, dominating pattern is passive, and we associate it with the phenomenon of consumer society and mass culture. Although consumption plays an indispensable economic role, unproductive free time does not encourage, or develop the creativity of an individual by which he would overcome, upgrade and enrich culture with new contents. On the other hand, the active spending of free time also generates a certain amount of consumption, but has quite the opposite effect, and in that sense

can act as a catalyst for entrepreneurship. Entrepreneurship is inseparably linked to free time, and even better with the free time of certain quality. First of all, it should be noted that people usually start entrepreneurial adventure in free time. The entrepreneurial idea is often developed as a result of the way of spending free time. Namely, if the entrepreneurial idea does not come as an upgrade of work experience it derives from experience related to our private interests. This is the reason why the entrepreneurship promotion programs don't produce desired results. Such programs are activated at a time when a person has already become an entrepreneur or has at least made a decision to start the entrepreneurial adventure. Entrepreneurship promotion programs do not significantly contribute to the expansion of entrepreneurial behavior. Instead, they support the entrepreneurial venture that has already begun. The need to create the circumstances and environments in which more people will be tempted to become entrepreneurs is neglected. It is therefore necessary to identify the circumstances in which people become entrepreneurs and then, by appropriate institutional infrastructure, encourage and support such circumstances as a wider social phenomenon.

## **2. HOBBY CULTURE AND ENTERPRENEURSHIP**

Hobby culture is a term designed for the purpose of this work, and the meaning of the term is obtained by linking these two concepts. Hobbies are the activities that people are most engaged in their free time, whose fundamental motivation is the search for pleasure, while culture usually refers to the complex set of institutions, values, concepts and practices that create the life of a particular human group and are spread and received by learning (Encyclopedia.hr 2018). Therefore, the term hobby culture signifies a major role that hobbies play in the life of a community, which is reflected in the frequent practice of hobbies, as a way of spending free time. In addition to frequent practice, social awareness of the value of such activity is also needed, as well as the transfer of such behavior patterns from one generation to the next. Just as the belief in the necessity of pursuing or maintaining a family relationship is deeply embedded in us; in the same way we should accept a conviction to practice some activity in free time, in order to achieve satisfaction. Just as society directs us toward its institutions and rituals: finding work or maintaining family contacts, the social community should encourage development of institutions that would direct us towards taking a hobby. We have already discussed that the development of hobby culture, i.e. active practice of free time, can be a potentially powerful catalyst for entrepreneurship. The reason for this lies in the complementarity of the hobby culture and entrepreneurial culture. People practice hobbies in order to achieve satisfaction, while the underlying motivation of an entrepreneur is gaining profit, receiving financial benefits for the hobbyists plays a secondary role. Moreover, they are often prepared to bear a serious financial loss, just to satisfy their interest (Gelber 1999). What is then the link between hobbies and entrepreneurship? Practicing a hobby can be seen as a pre-entrepreneurial phase. Hobbyists are often found within an entrepreneurial opportunity, regardless of whether they recognize it or not. They spontaneously develop ideas for new products and services; research about the market associated with their hobbies and are constantly getting educated about it. Visible connectivity allows hobby culture to act as a bridge between free time and launching own business. Although this developmental pathway from free time, via hobbies to entrepreneurship is known, hobbies have not yet received clear and explicit recognition for their role in the development of entrepreneurship. Usually, we hear that hobbies may eventually trigger the emergence of small businesses, and how their business potential ends there. To begin with, it should be clear that small businesses are more than a valuable part of a country's economy. The European Commission highlights the key role of small and medium-sized enterprises in economic growth, job creation and innovation (Eurostat, 2018). It should be identified that most of the entrepreneurial projects result in small businesses, if they are able to survive at all.

Some of these small companies will ultimately grow into medium to large, and exceptionally in large companies. Businesses developed from the hobbies are not exceptions in this regard. The growth of an enterprise depends on a number of factors and is not determined by its hobby origins. There is no doubt that not every hobby activity is equally economically potent. Due to the unbreakable link between hobbies with some industry and the broad possibilities of innovation in the same industries, hobbies are more than a significant source of entrepreneurial activity. First of all, there is the information-telecommunications sector and new technologies. It is a sector that has turned the world upside-down out of the "garage" several times. The mentioned revolutions were the result of youthful playfulness and creativity, encouraged through hobby. The entertainment industry is in its essence, in closest connection with hobby activities. Ecologic and natural products are also often developed thanks to the hobbyist impulse. In the broader sense, agriculture and the food industry are also subject to hobby innovation. Although all of this is significant, the greatest strength of the hobbyist experience lies in the potential of creation of entirely new types of products and services, and perhaps even the whole new industry. Having a hobby is still considered to be a frivolous activity. Mature people will often be ridiculed because they are spending their free time in such way. However, doesn't the entrepreneur show the same forms of behavior as a hobbyist? The entrepreneur also spends his free time playing the game. He, just like a hobbyist, is obsessed with some idea, explores it, seeks to improve and promote it. Freeing up time, and encouraging the active spending of it, can result in multiple benefits for the development of entrepreneurial culture. Hobby can be perceived as a polygon where we develop the qualities and skills needed for entrepreneurial success. If a hobbyist never decides to transform his or her hobby into entrepreneurial activity, or if he tries but doesn't succeed, he will still benefit from the experience that such projects offer. Enriched with new knowledge and skills he will be readier when an opportunity for another entrepreneurial venture comes. His experience can be used to help his employer. The positive effects of the hobbyist activity are not exclusively related to traditional entrepreneurship, but also to a corporate. Having that in mind, it should be pointed out that there are programs which are encouraging hobby culture, sponsored by large corporations. One of the brightest examples of this kind of behavior is the Formula Student contest. Automotive industry, being aware that a formal educational system cannot produce a workforce that fully meets their needs, finances teams of students who are making racing cars and competing with them. This project uses hobbyist activity as a means of development of entrepreneurial culture; therefore, the winner is not the one who reaches the goal first. The total result depends on: the evaluation of the construction and performance of the vehicle produced, as well as the evaluation of the financial and sales plan. In Germany, which is one of the leading countries in this sport, all major automakers and a number of companies closely related to the automotive industry, are involved in this project.<sup>1</sup> There are many examples that confirm the theory that hobbies can be entrepreneurial incubators. Did not Bill Gates, Steve Jobs and Mark Zuckerberg begin as hobbyists, before Microsoft, Appel, and Facebook were founded? Also Mate Rimac, the founder of Rimac Cars, he also started as a garage hobbyist. These are just examples of easily recognizable large companies created from the hobbies, but the final list of companies originating from hobbies is infinite. The prosperity of hobbyists in creating new business ventures should not be surprising, although people tend to spend on average only 2% of their free time practicing a hobby, this is the activity that they mostly identify with, and activity in which they invest most of their intellectual energy (Peppler 2017).

---

<sup>1</sup> For more details about *Formula student* see: :  
<https://www.formulastudent.de/about/concept/> and <https://www.formulastudent.de/partners/>

### **3. INOVATION AND ENTERPRENURIAL RISK**

If we look at entrepreneurship from the theoretical level, we will notice to what extent is expressed that subtle interlink between entrepreneurship and hobby activities. Innovation and entrepreneurial risk are, by modern economic definitions, the determining component of the concept of entrepreneurship. If we look at the modern definition of entrepreneurship, the presence of these two concepts is almost inevitable. Thus, Škrtić (2006, p.61) states: "An entrepreneur can be defined as a person gifted with a business spirit and managed with abilities, rich in knowledge of jobs and people, determined and willing to take the risk of enterprise management, based on innovation and constant development." Hobbies as a pre-phase of the entrepreneurship in these two categories can be a key help to future entrepreneurs.

#### **3.1. Innovation**

Innovation is one of the fundamental characteristics of entrepreneurship. Probably the most deserving for verification of entrepreneurs as the main driver of economic development is J.A. Schumpeter, who in his section of *The Theory of Economic Development* (1934) identifies innovation as an entrepreneur's function and goes so far as to discard the definition of entrepreneurship which only motivated by profit (Vranjican 2007: 193). Innovation is the use of new technological and market knowledge in order to offer a new product or service. The new product has a lower price, improved features, or features that it did not have, or have never existed, in the market before. Under the conditions of fierce competition on the market, every innovation that meets the need of customer in a better and more efficient way is important. The importance of innovation is even more obvious because of global competitiveness, shortening the life cycle of products, increasing technological ability and ever-changing customer requirements (Baković & Ledić-Purić 2011). Many people connect innovations and creativity with divergent thinking. Divergent thinking is associated with the game that is hidden in the hobby itself.<sup>2</sup> Divergent thinking does not provide a correct answer, instead we are free to seek different solutions and develop new ideas. In that sense, hobby opens the doors of creativity. The common result will be inventions. However, the invention needs to be commercialized. Therefore, invention becomes the first step of a long process that leads to the expansion and efficient use of a good idea. In order to become innovation, invention must be converted into a product or service that consumers want (Baković & Ledić-Purić 2011). For transition of invention to innovation, convergent thinking is of crucial importance, and has to be characterized by criterion, selectivity and the search for a correct answer. Freeing up the spare time and developing a strong hobby culture can give this segment of entrepreneurship the greatest contribution. The active pursuit of free time, in the form of hobby, creates an environment in which a person can fully indulge in his own creativity. Once a hobbyist becomes an entrepreneur, such a luxury will be unacceptable. Until then, they can enjoy the game. Psychologists, such as Teresa Amabile, attach the greatest importance of creative productivity to motivation, which will be maximized, if the person is dealing with a matter of their interest. Amabile in *Creativity in context* (1996) emphasizes the difference between intrinsic and extrinsic motivation and describes their influence on creativity. In her opinion, intrinsic motives, such as enjoying creative process and the desire to solve the problem are necessary for creativity, while extrinsic motives, such as the desire for glory and richness, can in some situations even prevent creativity (Pandža 2016, p.3). The hobbyist is not under pressure of time. He can dedicate all of his time to project without fear of his project being canceled, or innovation coming too late. He is not yet burdened with the question of ultimate profitability of innovation, as he creates for his pleasure. For hobbyist, learning is not a burden because any new information represents a reward, and at the same time satisfies his passion and hunger for extra knowledge. The hobbyist can make a mistake; invest time, money and energy in projects

---

<sup>2</sup> The concept of divergent thinking was introduced by American psychologist J.P. Guilford. (Guilford 1971).



that fail, and still enjoying the result of his work, because he receives pleasure just from dealing with a certain matter. These unique conditions cannot be replicated in a corporate environment and are therefore crucial for further expansion of the boundaries. Creator, as a hobbyist, is really in a specific position. He does not face the problem of ignoring his potential by his superiors. The hobbyist does not have the problem of insufficient encouragement of creativity from the internal or external environment; or undeveloped motivation system that encourages the creativity of individuals in the organization (Jakovljević, Radman Peša, & Čovo 2012). Economic science is trying to design models of organizations that will enable creative action, while disabling the group to suppress the creativity of an individual (Jakovljević, Radman Peša, & Čovo 2012). Such networked creativity for hobbyists is created naturally. Hobbyists are networking in the community, sharing their knowledge, and their discoveries. They are fully flexible. They choose how many, when, and how they want to work in the team. Teamwork does not produce negative consequences on the creativity of an individual, as he is always free to return to individual engagement. This selfless interaction allows hobbyists to create new solutions based on the ideas of others (Pepler 2017). A smaller part of the hobbyist will grow into successful entrepreneurs. But even those who do not become entrepreneurs will often, knowingly or unknowingly, contribute to the entrepreneurial success of hobbyists, by creating solutions that will in the end be embedded in their product or service. This attitude has its own affirmation in psychology, so Dean Keith Simonton presents a view of creativity through evolutionary thinking. The basic idea is that creativity, as well as organisms, is the result of a large number of blind variations, out of which, only the best remain. Blind variations are enabling the creation of a large number of innovative ideas, which are then accepted or rejected based on their value. (Pandža 2016, p. 4). We could say that there is a free research team available to hobbyists, whose mistakes and successes will ultimately affect the product, even though they are unaware of their participation in the process of creation of a new product. The development of the natural products industry in Croatia, for the past twenty years, has witnessed the creative power of the hobbyist experience. Successful companies like Suban d.o.o. are laid out on the hobby foundations (Suban.hr 2018). The fondness of founder Milan Suban for herbs over the past 20 years, has made it possible for him to create a successful company, whose products can be found in almost all pharmacies in Croatia. The final result is a company employing about twenty employees and turning a million euros a year (Poslovni dnevnik 2009). Beekeeper hobbyist Ivan Bračić, started a small family business. Today, its company PIP is a regional manufacturer of beekeeping and bee products with one of the most modern facilities in this part of Europe. Located in the Pisarovina entrepreneurial zone, PIP's products are exported to several European countries, and receiving recognition at innovation fairs worldwide (Inovatorstvo.com 2014). These examples are no exception. The natural cosmetics industry is one of the fastest growing in Croatia. Brands such as the "Mala od Lavande", funded by "Priroda zna" j.d.o.o., or "OLIVAL" funded by Olival d.o.o., have conquered Croatian market and are slowly expanding across the region and the European Union (Poslovni dnevnik 2017a). When we research it in more detail, we will notice that the foundation of all of these companies is hobby. Natural product industry is not the only growing industry based on creativity, which comes from hobbies. In Croatia brewing industry is also growing fast. The leaders of this scene: "Nova runda", "Zmajaska pivovara", "Varionica" and "Medvedgrad", have laid the foundations of the Croatian "craft beer", and they have started a small revolution, which resulted in more than 30 crafts breweries. They are small, independent, innovative brewers, with few employees, where maximum care is devoted to quality and the creation of new flavors. The current market share of "craft beer" in Croatia is about 2%, with the expectation for further growth (Poslovni dnevnik 2017). These companies originally came from local beer lovers and home brewing hobbyists. The potential of this industry is best illustrated by US data which is also the source of this hobbyist-entrepreneurial phenomenon. In the US in 1980, around 45 companies

produced beer. It was a fairly low point in the US brewery industry. Since then, the American scene of "craft beer" has exploded. Now there are more breweries than ever, and annual sales of "craft beers" is worth about \$ 22.3 billion, which is about 12 percent of the total market share. (Agrobiz 2018). Once the hobbyist succeeds in placing his product, or service, on the market and becomes an entrepreneur, he will continue to profit from his hobby experience. Above all, he will intuitively understand the creative processes and conditions necessary to build a creative environment. Thanks to the knowledge of the hobby scene which he left, he will have access to the specialist labor force; passion and experience that will be enable his company (if well structured) survival on the market, and further development by upgrading and developing new products and services. So, it is not surprising that small businesses and individuals are responsible for the disproportionate share of most important innovations and innovations (Samuelson & Nordhaus 2005, pp. 196-197).

### **3.2. Entrepreneurial risk**

We have already identified risk as one of the key components of entrepreneurship concept. Furthermore, Richard Cantillon in the first known definition of entrepreneurship in his "General Discussion on Nature of Commerce" published in 1725, emphasizes the risk and uncertainty as essential determinants of entrepreneurial function. For him, the entrepreneur is a person who buys at known and sells at unknown prices. In order to clarify entrepreneurship, he used the example of a leaseholder who pays contracted, well-known income to the landowner and workers, but he sells products at indeterminate prices, therefore: unknown (Vranjican 2007, p. 187). The risk is actually uncertainty that is based on the quantitatively determinable probability of its occurrence. The uncertainty itself, in the broader sense, is impossible to calculate and attribute the likelihood. Moreover, in most cases it is not even possible to reduce it by researching nature and causes linked to the phenomenon. (Ritchey et al., 2004). Therefore, the basic criterion for distinction between risks and uncertainty, is that the probability of occurrence of a certain event in the case of a risk is determinable, and in the case of uncertainty remains unrecognizable (Rančić 2007, pp. 656-657). It is well-known that the advantage of entering into entrepreneurship is gaining control over personal destiny. As much as it a sound motivating, to most people, such a process is fearful. Entrepreneurial theorists know well that this fear is rational. Destruction is a characteristic of entrepreneurship, which cannot be found in definitions, but everyone is aware of. If entrepreneurial innovation is successful and recognized in the market, it will reflect negative on those on the market who are offering old ideas. This is so-called Schumpeter's creative destruction, which is consisted in creation of new values by destroying existing market structures. On the other hand, if entrepreneurial fear gets realized, the entrepreneur will pay the price with his own poverty. Because they are aware of the possibility of failure, people often do not try to become entrepreneurs, even though they have created an entrepreneurial idea of serious potential. This problem is particularly noticeable in post-socialist countries like Croatia. In the conditions of the planned economy, entrepreneurial role was carried out by people coming from communist party which did not bear the risk of their own impoverishment. Consequently, the culture risk free, or even worse: pseudo-entrepreneurship, was developed (Vranjican 2007). Under the term prone to risk, we consider the psychological tendency of individuals to accept risks, or the impact of the perceived risk on making business decisions. The core of the attitude towards risk is the theory of money's usefulness. Like many other goods, money for most people shows the characteristics of decreasing marginal utility. That means, to most people, that every additional unit of money represents additional desirable benefit. This added benefit, once the desired amount is reached, is smaller and smaller. Empirical economics methods have established that the risk of fear in most cases, decreases with the amount of available money. In other words, rich person is less vulnerable to losing money, and is more prone to risky behavior. This, of course, works in reverse, as we are poorer we are more unwilling to invest, in the hope of achieving some future

greater benefit. Consequently, the relatively low level of income in Croatia, prevents the average citizen from entering entrepreneurial adventure. The risk that is primarily rejected by potential entrepreneurs is financial risk. Since investing does not bring benefits right away, it basically represents a delay in current spending for the purpose of eventual increase in future consumption. Although the investment is actually a category of consumption, for the purposes of this paper, investment can be compared to savings, which manifests in future benefits. Investing exists only when a person does not decide to spend their entire income on classical spending. The hobby itself has the potential for minimizing the fear of risk. The reason lies in an interesting phenomenon that deserves more attention, for the purposes of this paper we will call it, a phenomenon of double benefit. We have already stated that hobbyists are often prepared to bear a serious financial loss in order to satisfy their interest. This hobby's tendency for classic spending often turns into a tendency to capital spending, i.e. investment. The reason for this kind of behavior is hidden in the promise of double benefits. For a hobbyist investment is not just a promise of higher future spending that is directed towards satisfying his interests and needs, moreover his current need to practice a hobby gets satisfied. There is another effect of the hobbyist activity that contributes to the minimizing the fear of risk. As hobby in its essence is a game, such spending of free time results in feelings of enthusiasm and optimism. Such an effect of hobby is not surprising, because the hobby is among other things, a search for pleasure. The empirical ideas of economic science have noticed, longtime ago, that there is a relationship between pessimistic predictions and bad investments (Samuelson & Nordhaus 2005, pp. 459,460). Hobby experience can be particularly important for promoting women's entrepreneurship. According to the statistics of the Croatian Chamber of Trades and Crafts, in December 2016 there were 25,723 female craft owners in Croatia, which is 33.1% of the total number of crafts in Croatia (HOK 2018). Although the inequality of women and men is a complex issue, one of the reasons for a smaller number of women in entrepreneurship is the relatively lower tendency of women towards financial risk. Therefore, Bernd Finger states: "It is typical that women are less likely to take risk than man, and it is like that from early childhood, and in all cultures. However, reality is more complex. Men are more likely to take risks in the field of finance, while women are more likely to act in social activities." (Znananost 2011). This view is also confirmed by domestic research. The survey, conducted on a sample of 79 managers of large Croatian companies, shows that men are more likely to take a risk than a woman. At the same time, top management is constituted of 75% of men, compared to only 25% of women (Prester 2004, p. 15). Some other studies conducted in Croatia have yielded similar results (Sikavica & Bahtijarević-Šiber 2004, pp. 58-64). Having that in mind, the ability of hobbies to decrease the impact of financial risk, opens up significant opportunities for women's entrepreneurship. The above-mentioned flourishing industry of natural cosmetics is based on the success of women's hobbyists. The founder OLIVAL d.o.o., Vlasta Pojatina says: "I was working in the city pharmacy and it all seemed like I will be working there till retirement. My hobby was the production of cosmetics for myself and my family. I was young, enthusiastic and I have desired to have private company, so I started the business. I saw that the products being sold, new orders were coming, so I quit the job at the pharmacy, rented the space and bought the first mixer." (Pacek 2014). Today OLIVAL has steady growth of 35% in the last three years. They have built a new business building and manufacturing space. They export to countries in the region. They will soon start exporting to Germany and are in the final phase of negotiations with partners from the Middle East and Finland. (Stratego 2017). Besides the fact that a hobby can inspire a person to face entrepreneurial risk, sometimes hobbies teach a hobbyist a lesson about risk management. Since risk management is often more art than science, such experience is more than crucial in the during the future entrepreneurial activity. The reason lies in the necessity of implementing such a risk management system in every business venture. In addition, the "Risk Management System can be defined as a complete process of prediction,

measurement and monitoring of relevant and potential risks, and analyzes related to potential losses" (Osmanagic Bedenik 2003, p. 69). How do hobbyists gain experience in risk management? Hobbyists, especially those who make something in their spare time, tend to sell part of their products to cover their investment in hobbies. Such practice is often imposed as a necessity, since many hobbies require serious investment. If a hobbyist decides to do so, he or she will have to face the risks that occur in a classical entrepreneurial venture. They face this risk in the first stage, which is development of business ideas. At this stage market interest for the product, or service, that hobbyist offers gets assessed, followed by risks from the business realization phase. This phase will test the hobbyist's ability to plan and develop financial structure, followed by the risks of the production and sales phase. (Vranjican 2007, pp. 201-203) The market is unpredictable and the buyers are demanding. If hobbyist fails to attract enough customers, they will feel the destructive nature of entrepreneurship. Just like in the case of a real entrepreneur, failure will result in their impoverishment. If not, the registration of business and becoming the entrepreneur is logical next step.

#### 4. CONCLUSION

The paper emphasizes the creative potential of free time, with the aim of affirming the idea of the development of hobby culture as a catalyst for entrepreneurship. The reason lies in the complementarity of the hobby of culture and entrepreneurial culture. If we distinguish innovation and entrepreneurial risk as the two fundamental theoretic determinants of the entrepreneurship concept, we will see that hobby activity solves the underlying problem of encouraging the expansion of entrepreneurial behavior. The active spending of free time in the form of hobbies encourages creative behavior and minimizes the fear of risk. It is therefore necessary to develop an institutional infrastructure that will enable a potential entrepreneur easier entrance to economic life. We need a bridge that will act as a natural link between the new educational system and the economy. We believe that this sought-after bridge could be found in combination of two factors: free time factors and fun factor. These two concepts are united within the concept of hobby, and therefore we consider that the development of hobby culture is potentially a powerful catalyst for entrepreneurship.

#### LITERATURE:

1. *Agrobiz: Od kućnog kuhanja kraft piva do milijardera*. (2016). Retrieved 11.11.2018. from <https://www.agrobiz.hr/agrovijesti/od-kucnog-kuhanja-craft-piva-do-milijardera-2615>
2. Baković, T., Ledić-Purić D. (2011). *Uloga inovacija u poslovanju malih i srednjih poduzeća*. Zagreb: Sveučilište u Zagrebu. Retrieved 12.03.2018. from <https://hrcak.srce.hr/75460>
3. Bedenik Osmanagić, N. (2003). *Kriza kao šansa*. Zagreb: Školska knjiga, Zagreb.
4. *Enciklopedija.hr: kultura, hobi*. Retrieved 17.03.2018. from <http://www.enciklopedija.hr/natuknica.aspx?id=34552>, <http://enciklopedija.hr/Natuknica.aspx?ID=25826>
5. *Eurostat - Statistics on small and medium sized enterprises*. (2018). Retrieved 04.03.2018. from [http://ec.europa.eu/eurostat/statistics-explained/index.php/Statistics\\_on\\_small\\_and\\_medium-sized\\_enterprises](http://ec.europa.eu/eurostat/statistics-explained/index.php/Statistics_on_small_and_medium-sized_enterprises)
6. Farkaš, H. (2014) Slobodno vrijeme kao resurs u postindustrijskome društvu. In T. Pranić (ed.), *Amalgam, No. 6-7*. Retrieved 12.03.2018. from <https://hrcak.srce.hr/134855>
7. *Formulastudent.com: Concept, Partners*. Retrieved 04.03.2018. from <https://www.formulastudent.de/about/concept/> & <https://www.formulastudent.de/partners/>
8. Gelber S. (1999). *Hobbies - Leisure and the Culture of Work in America*. New York: Columbia University Press.
9. Guilford, J. P. (1971). *The nature of human intelligence*. London: McGraw-Hill.

10. Jakovljević M., Radman Peša A., Čovo P. (2012). Integrativni organizacijski model kreativnosti i inovativnosti (omki): Primjenjivost na srednja i mala poduzeća u Republici Hrvatskoj. In Đ. Benić (ed.), *Ekonomska misao i praksa*, No.1, Dubrovnik: Sveučilište u Dubrovniku, Retrieved (15.03.2018) from <https://hrcak.srce.hr/83760>
11. *Hrvatska obrtnička komora (HOK): Obrtništvo u brojkama*. Retrieved 17.03.2018. from [https://www.hok.hr/statistika/obrnistvo\\_u\\_brojkama](https://www.hok.hr/statistika/obrnistvo_u_brojkama)
12. Pacek, T. (02.06.2014). Kvalitetna krema stvara se godinama. 24 sata. Retrieved 17.03.2018. from <https://www.24sata.hr/lifestyle/vlasnica-olivala-kvalitetna-krema-stvara-se-godinama-368899>
13. Pandža V. (2016). *Koncept kreativnosti: različiti pogledi u psihologiji*. Zagreb: FSB, Retrieved 15.03.2018. from <https://www.fsb.unizg.hr/brodogradnja/UZIR-2016-Essay-Viktor-Pandza.pdf>
14. Peppler, K. (2017). *The SAGE Encyclopedia of out of school learning*. London: SAGE Publications.
15. *Poslovni dnevnik: Bakinim tajnama do godišnjeg prihoda većeg od milijun eura*. (2009). Retrieved 17.03.2018. from <http://www.poslovni.hr/domace-kompanije/bakinim-tajnama-do-godisnjeg-prihoda-veceg-od-milijun-eura-115935>
16. *Poslovni dnevnik: Pivo u hrvatskoj zapošljava 28 000 ljudi, proizvodnja raste*. (2017). Retrieved 17.03.2018. from <http://www.poslovni.hr/poduzetnik/pivo-u-hrvatskoj-zaposljava-28000-ljudi-proizvodnja-raste-330449> (17.03.2018)
17. *Poslovni dnevnik: Prirodna kozmetika prvo se dokazala doma i u regiji pa lakše osvaja svijet*. (2017a). Retrieved 17.03.2018. from <http://www.poslovni.hr/hrvatska/prirodna-kozmetika-prvo-se-dokazala-doma-i-u-regiji-pa-lakse-osvaja-i-svijet-331275>
18. Prester, J. (2004). Sklonost riziku hrvatskih menagera. *Slobodno poduzetništvo*, Broj 4, Zagreb: TEB.
19. Rančić, N. (2007). Načelo opreza u teoriji i politici zaštite okoliša i javnog zdravlja. In D. Hrabar (ed.), *Zbornik Pravnog fakulteta u Zagrebu*, 57 (3), Zagreb: Pravni fakultet.
20. Ritchey T., Lövkvist-Andersen, A., L., Olsson, R., Stenström, M. (2004) *Modelling Society's Capacity to Manage Extraordinary Events*. Swedish Morphological Society. Retrieved 11.11. 2018. from <http://www.swemorph.com/pdf/sra.pdf>
21. Samuelson, P.A., Nordhaus, W.D. (2005). *Ekonomija*. Zagreb: Mate.
22. Sikavica, P., Bahtijarević-Šiber F. (2004). *Menadžment - Teorija menadžmenta i veliko empirijsko istraživanje u Hrvatskoj*. Zagreb: Masmedia.
23. *Stratego: Ploval novom proizvodno-uredskom zgradom povećao kapacitet za 5 puta*. (2017). Retrieved 17.03.2018. from <https://www.stratego.hr/2017/04/07/olival-novom-proizvodnom-uredskom-zgradom-povecao-kapacitete-za-5-puta/>
24. Suban.hr: O nama. Retrieved 17.03.2018. from <https://www.suban.hr/o-nama/>
25. Škrčić, M. (2004). *Poduzetništvo*. Zagreb: Sinergija.
26. *Udruga inovatora hrvatske: Od obiteljskog hobija do regionalnog lidera*. (2014). Retrieved 17.03.2018. from <http://www.inovatorstvo.com/intervju-ivan-bracic-od-obiteljskog-hobija-do-regionalnog-lidera/a621>
27. Vranjican, S. (2007). *Politička ekonomija*. Zagreb: Pravni fakultet.
28. *Znanost: Tko je spreman na rizik i što utječe na sklonost riskiranju*. (2011). Retrieved 29.03.2018. from <http://znanost.st/znanost-drustvene-znanosti/9/rani-upozoravajući-znakovi-kolapsa-stanovništva/294>

## NON-FINANCIAL INFORMATION DISCLOSURES AND CSR REPORTING VERSUS THE INFORMATION ASYMMETRY PROBLEM

**Ewelina Papaj-Wlislocka**

*University of Economics in Katowice  
ul. 1 Maja 50, 40-278 Katowice, Poland  
ewelina.papaj@ue.katowice.pl*

### **ABSTRACT**

*The 21st century is called the era of information. Access to information is equally important for potential investors as well as recipients of financial statements. As researches show, reports users expect a growing range of disclosed information regarding not only traditional financial, but also non-financial data. Therefore, there arises a question about the scope and reliability of data disclosures and their impact on the problem of information asymmetry. Poland's implementation of the Directive 2014/95/EU has crucial importance taking into account the changes in the Accounting Act, which introduced an obligation for the largest Polish companies to disclose non-financial data. The aim of the article is to draw attention to the concept of CSR reporting as well as non-financial information disclosures and their impact on the problem of information asymmetry observed in modern companies. On the basis of a critical analysis of the literature of subject and legal acts, author will describe the problem of information asymmetry and the possibilities of its's reduction by implementation concept of CSR and CSR reporting as well as non-financial information disclosures. In empirical part of this paper, PARP Report will be analysed in order to present results of implementing CSR concept in 123 Polish companies in 2016. The aim of article is also to underline the differences between CSR reporting and non-financial information disclosures. Research contribution of this paper is to provide a better understanding of discussed phenomena as well as to initiate a discussion on the problem of information overload.*

**Keywords:** *asymmetry of information, corporate social responsibility (CSR), modern financial reporting, non-financial data*

### **1. INTRODUCTION**

Recent years are a time of very intense changes both in social life and in business realities. With the development of modern technologies and the advancement of the Internet, access to information is common and national borders no longer constitute any barriers. Access to reliable information might be a determinant of the success of the company. However, as economic practice shows, equality in access to information is still a significant problem. Another challenge is the comparability of the data published in the reports, especially for enterprises operating in different countries. Recipients of financial statements, among which the dominant group are investors, are becoming more and more demanding and expect very high quality of presented data. The trends which are observed in Western European countries also have a large impact on the changes in the area of reporting. Particularly visible is the interest in integrated reporting and disclosure of non-financial data (Walińska, 2015, pp.152). Taking into account the changes observed in the Polish accounting system, non-financial information disclosures are of particular importance. The aim of this paper will be to draw attention to the role of non-financial disclosures in reducing the problem of information asymmetry in contemporary enterprises. Basing on the analysis of the literature, the phenomenon of asymmetry of information and its' effects in business processes will be characterised. In the next part of the article, activities proposal that can reduce this problem will be presented. It will cover the CSR concept implementation, reporting and the idea of non-financial disclosures as a part of the

classic financial reporting. These phenomena are very similar, however they have different assumptions from the legal regulations' perspective. The article will be an attempt to distinguish them.

### 1.1. The problem of information asymmetry

As it has been emphasised in the introduction, contemporary socio-economic conditions placed information among the most crucial factors influencing market success. Thus, equal access to information has become one of the major economic problems (Kubiak, 2011, pp.45-50). As a common saying has it: "Knowledge is power", drawing attention to the possibility of achieving certain benefits owing to access to information. On the other hand, it suggests the existence of the problem of information asymmetry. According to the well-known definition, information asymmetry is a phenomenon in which one group of people has the knowledge that is not easily accessible to others (Begg, Fischer, Dornbusch, 2007). In literature of the subject, the notion of information asymmetry is often used interchangeably as "information opacity" or "information non-transparency". The existence of information asymmetry is a proof that the scope of information available to parties involved in business processes is very diverse (Brown, Deegan, 1998, pp.22). Precursors of scientific research in the area of information asymmetry were the Nobel Prize winners in the field of economics - Akerlof, Spence and Stiglitz (2001). Considering the problem of asymmetry of information from the point of view of the company's activity, it should be noted that it is most often observed between the management (insiders) and investors (outsiders). The information opaqueness between these entities has its source in the conflict of interests between them. The Management Board as an internal authority has unlimited access to the information resources of the entity, while an investor is dependent on information coming from the board in published reports. What is more, the management also has an impact on the future operations of the entity, which is not always made known to investors. The lack of sufficient information regarding the future investment activity that is most serious for investors. Management and investors are not the only groups exposed to the information asymmetry problem. It also exists between owners and creditors as well as among minority and majority shareholders (Skowroński, 2005, pp.155). The occurrence of information asymmetry has many negative effects on enterprises, their examples are presented in Figure 1.

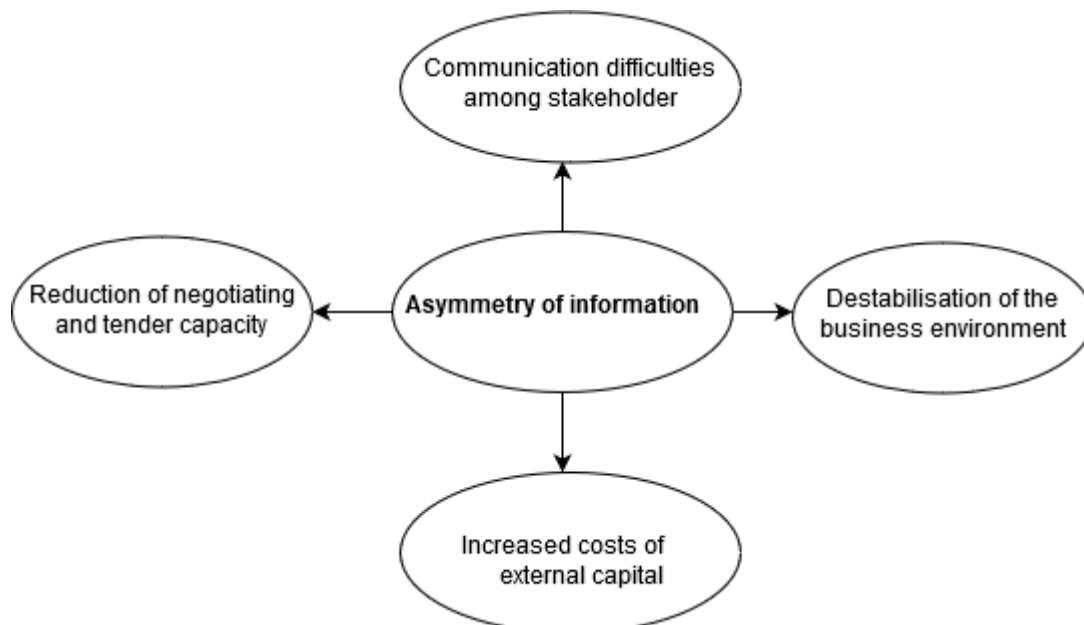

Figure 1: Examples of negative effects of information asymmetry  
Source: Own study

The asymmetry of information has a destabilising effect on the business environment of the enterprise, especially considering increased costs of external capital, as well as difficulties in finding a sales market (Donaldson, Dunfee, 1994, pp.252-255). A high degree of information asymmetry tends to discourage potential investors from engaging capital. Thus, the company might be forced to guarantee higher rates of return, and in consequence, increase the costs of internal capital for running a business. Another negative aspect related to information asymmetry could be reducing effectiveness of marketing activities, as well as the worse effects of negotiations and tenders. One should also noticed the negative consequences that take place within the organization. Inequality in access to information may result in communication difficulties between employees and cause complications in decision making process (Hobbs, 2004, pp.395). Considering the above examples of negative impacts of information asymmetry on the functioning of enterprises, steps to maximally mitigate the information asymmetry effects are necessary. Undoubtedly, in a market economy it is not possible to completely exclude the problem of information opacity. The market trends also contribute to easing the effects of information asymmetry (Guthrie, Parker 1990, pp.160). In the era of investors' increasing awareness and growing popularity of the idea of social corporate responsibility (CSR), companies decide to prepare more and more extensive reports with a very high information value (Blajer-Gołębiowska, 2012, pp.25-60) .

## **2. METHODS**

The discussed problem of information asymmetry may be mitigated by implementing CSR concepts in enterprises and increasing the standards of published reports. In Poland, it is currently a very popular phenomenon. The Directive 2014/95/EU, recently introduced into the Polish law, is erroneously identified by business as an obligation of CSR reporting. As part of the study, examples of activities undertaken by Polish enterprises will be presented in connection with the introduction of corporate social responsibility concept. In the following part of the paper the most popular CSR areas among Polish companies will be presented. The empirical part features an analysis of the companies' benefits associated with the implementation of the CSR concept. The analysis presented in the article was based on the results of the Report of the Polish Agency for Enterprise Development (PARP) conducted on 123 Polish companies, which in 2016 have decided to implement the principles of the CSR. Distinguishing between CSR activities and reporting and disclosing non-financial information will form the final part of the analysis.

## **3. RESULTS AND DISCUSSION**

One of the ways to mitigate the negative effects of information asymmetry is to provide transparent reports. Managers and business owners who want to reduce the costs of external capital should provide potential and current investors with reports that will meet their expectations (Harrison, Laan Smith, 2015, pp. 940). These reports should also strengthen confidence in the company (Lehman, 2017, pp.30-41). The solution are the CSR (Corporate Social Responsibility) reports, very popular in Western Europe and the U.S.A., which are also gaining popularity in Poland. The basis for creating a CSR report lies in the concept, according to which the company, in building its strategy, includes social interests, environmental protection, as well as relations with stakeholders on a voluntary basis (Stanton, Suttipun, 2012, pp 99-110). The creation of the report is the last stage, the final effect, which often serves as a marketing tool for the company (Morgan, 1988, pp.477-485). The most important factor is the general concept and actual activities consistent with the CSR assumptions and their application in the company (Frederick, Davis, Post, 1988, pp.78). These include, among others:

- a) Compliance with human rights - a fundamental value



- b) Determining a wide range of standards and requirements - developed in accordance with applicable law
- c) Abiding "soft law", such as guidelines developed by OECD, UN, GRI
- d) Creating a space for dialogue with stakeholders (Svenson, Wood, Callaghan, 2010, p.338)

What is important is that CSR activities should not be identified with charitable activities, which is often the case in Polish enterprises. According to the best practices applied throughout the world, CSR activities should be related to the area of basic business activity. Table 1 presents examples of activities carried out by Polish companies divided into the development of the local community, pro-ecological activities and social involvement.

*Table 1: Examples of corporate social responsibility (CSR) activities*

*Source: Own elaboration*

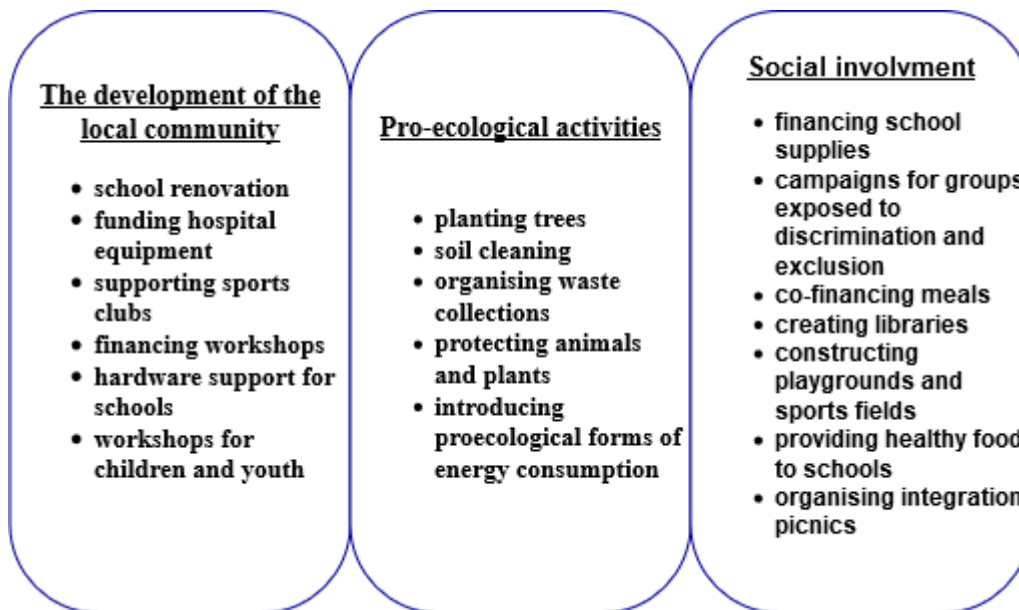

Considering the subject of corporate social responsibility, it is worth paying attention to the meaning of the word "reporting". Beside the standard disclosures concerning social, labour, environmental, human rights and anti-corruption information, it is primarily a process that can provide tangible benefits to the company. The Polish companies are also convinced about the benefits of actions aligned with the philosophy of corporate social responsibility. Although the popularity of CSR reporting in Poland is not as wide as in Western European countries, there are undoubtedly more and more companies publishing social responsibility reports every year. Figure 2 presents three main areas within which Polish enterprises implement the CSR concept:

*Figure following on the next page*

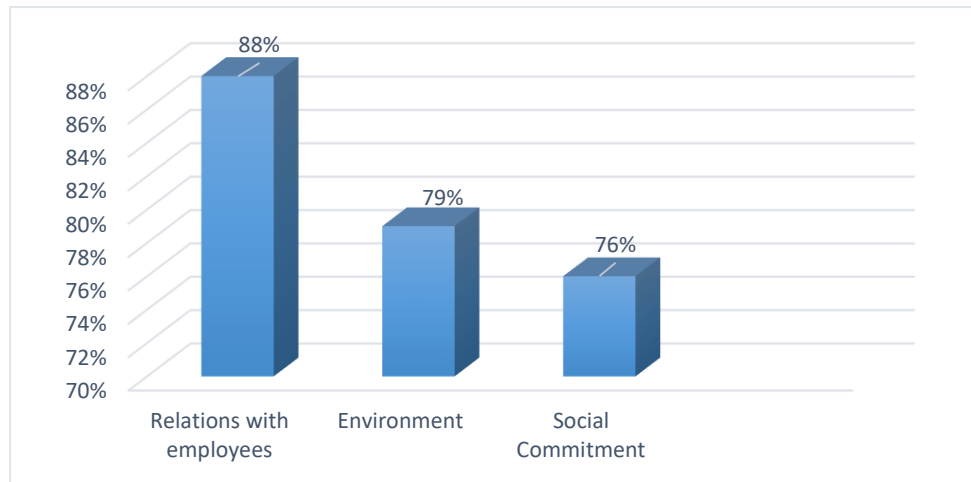
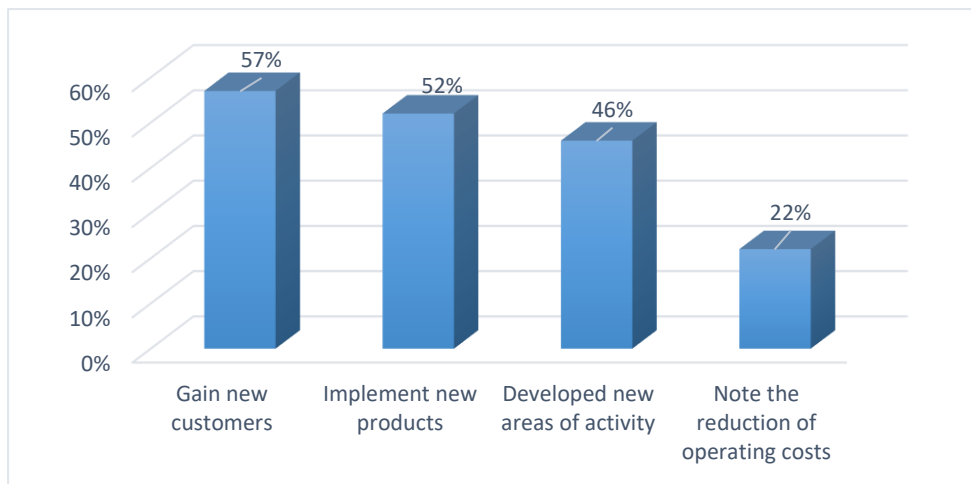

*Figure 2: Areas of CSR implementation among Polish companies*

*Source: Own elaboration based on PARP Report 2016 [[http://odpowiedzialnybiznes.pl/wp-content/uploads/2016/06/parp\\_PL\\_Raport\\_koncowy\\_2016\\_05\\_16\\_FIN.pdf](http://odpowiedzialnybiznes.pl/wp-content/uploads/2016/06/parp_PL_Raport_koncowy_2016_05_16_FIN.pdf)]*

The analysis of Figure 2 shows that Polish companies place the highest importance to the development of the CSR concept in the area of relations with employees. This is particularly important considering the current situation on the labour market. Recent years clearly show that in Poland an employee's market can be observed. Staff shortages and increasing recruitment problems make Polish companies appreciate the value of a well-qualified and committed employee. Hence, they make every effort to keep their staff for as long as possible. It is connected not only with guaranteeing a fair remuneration, but also with caring for non-pay benefits such as: training, subsidizing rest for employees and their families, providing access to free health care and guaranteeing a positive atmosphere in the workplace. A similar scope of CSR concept implementation covers areas related to the environment and involvement in the local community. A larger percentage of companies declared activities in the area of the natural environment. It is connected with the growing awareness of the need to take care of the natural environment, especially in the topics of air and water pollution. It should be also emphasised that requirements in the area of natural resources and environment protection is also increasingly a subject of legal regulations in various countries. The third area within the CSR concept is the company's involvement in the life of the local community. Such activities include for example: financing school supplies, constructing playgrounds and sports field or providing healthy food for schools. It is increasingly important to show company's commitment into local community. This way, company acquires social acceptance for its operation. There is no doubt that the stimuli that attract more and more companies to CSR reporting are the benefits that result from the disclosures. Figure 3 presents the effects resulting from CSR reporting by Polish companies. The data comes from the evaluation report "Improving the competitiveness of regions through corporate social responsibility" conducted in 2016.

*Figure following on the next page*



*Figure 3: Benefits for Polish companies resulting from the implementation the CSR Concept*  
Source: Own elaboration based on PARP Report 2016 [[http://odpowiedzialnybiznes.pl/wp-content/uploads/2016/06/parp\\_PL\\_Raport\\_koncowy\\_2016\\_05\\_16\\_FIN.pdf](http://odpowiedzialnybiznes.pl/wp-content/uploads/2016/06/parp_PL_Raport_koncowy_2016_05_16_FIN.pdf)]

Among the benefits of implementing good CSR practices, the opportunities for gaining new customers and introducing new products are most significant. Socially responsible enterprises tend to be able to develop new areas of activity more easily. Among the entities covered by the evaluation program "Increasing the competitiveness of regions through corporate social responsibility", 22 % observed a reduction in operating costs. This may indicate that CSR reporting has a significant impact on reducing the negative effects of information asymmetry. Taking into account the case of this study, attention should also be drawn to the distinction between the concepts of CSR reporting and disclosing non-financial data. In practice, these concepts are often treated as identical, but in fact they bear a different meaning. Changes in the Accounting Act which follow the implementation of Directive 95/2014/UE have to be linked with the obligation of preparing CSR reports. CSR reporting is a holistic concept having influence on the entire enterprise management process. CSR reporting must be preceded by adoption of a philosophy related to social responsibility (Fuente, García-Sánchez, Lozano, 2016, pp.737-750). Reporting is therefore a final effect of all actions taken in the area of local community development, pro-ecological activities and others. Disclosures are a much narrower concept, which means presenting a certain minimum of information related to non-financial data, defined by law. The article 49b has been added to the Accounting Act, which treats the need to disclose the minimum scope of disclosures (Papaj, 2016, s.526). The scope of non-financial information disclosures includes, inter alia:

- a) description of the business model of the company,
- b) key non-financial performance indicators related to the company's operations,
- c) description of the policies used by the entity in relation to social, employment, environmental issues, respect for human rights and counteracting corruption and bribery, as well as a description of the results of these policies,
- d) description of due diligence procedures - if the entity uses them under the above policies (...),
- e) description of significant risks related to the entity's operations that may have an adverse effect on issues, including risks related to the entity's products or its relations with the external environment, including business partners, and a description of managing these risks (Accounting Act, art. 49b, 2017).

In the process of data disclosure, a company is able to apply the standards, guidelines or principles depending on its choice.

The most popular guidelines in this area include the Global Reporting Initiative (GRI) and EMAS Standards and Global Compact. The Directive permits using own company's standards or other internationally recognised principles, however, it imposes an obligation to inform in reports about company's choice. This underlines the fact of large freedom in the form of the mandatory disclosures. However, one should be aware that the above-mentioned regulations do not fully cover the idea of CSR reporting, because they do not change the approach to conducting business. The scope of non-financial information that must be disclosed by large public trust companies is in a way similar to that reported in the CSR, but is not as extensive and is not related to specific activities adopted by enterprises. Therefore, it is not fair to say that the EU Directive imposed on companies from Member States an obligation to report CSR. CSR concept is by definition of a voluntary nature. The actions of the European Union were aimed at increasing the comparability of data, including that of a non-financial nature.

#### 4. CONCLUSION

The considerations presented in the article touch some very current issues faced by today's enterprises, namely unequal access to information. Despite widespread access to the Internet, there are still groups of stakeholders that receive insufficient data. Of course, the complete elimination of information asymmetry is not possible. However, from the point of view of the negative effects of this phenomenon presented in the study, it is desirable to limit it. The changes taking place in the modern world contribute to the growing popularity of non-financial data. Foreign literature in the area of accounting increasingly emphasises the need to extend traditional financial reports by including the presentation of non-financial data (Kieso, Weygandt, 1995). The institutions of the European Union supervise the transparency and comparability of published data, which through their directives impose specific obligations on member states as part of the unification of reporting. The disclosure of non-financial data is undoubtedly a new challenge that must be faced by today's business. Observation of business practice allows to notice that there is a problem with distinguishing CSR activities, CSR reporting and disclosure of non-financial data. The article, trying to distinguish these concepts, also presented practical examples of CSR activities that are popular in Polish enterprises and presented the benefits resulting from their implementation. The issue of CSR reporting and disclosure of non-financial data has also been distinguished. Despite significant terminological differences, it should be noted that both extensive CSR reports and limited to the statutory minimum disclosure of non-financial data might lead to an increase in the amount of information disclosed. The greater amount of information presented may contribute to reducing the problem of information asymmetry. However, a very significant problem is verifying the disclosed non-financial data or CSR reports. According to the applicable law, they are not subject to mandatory auditing by an auditor. Thus, the question arises about the reliability of the disclosed information. What is more, taking into account CSR reports, a very frequent flaw is their growing volume. Thus, a research question can be formulated, which could serve as an inspiration for further scientific work, namely whether by eliminating the problem of information asymmetry, enterprises do not contribute to the information overload phenomenon, which from the point of view of decision-making processes of recipients may appear as much if not more harmful.

#### LITERATURE:

1. Act of Accounting (Dz.U. 2016, item 1047).
2. Begg D., Fischer S., Dornbusch R., (2007). *Microeconomics*, PWE Publisher, Warsaw.
3. Blajer-Gołębiowska A. (2012). *Asymmetry of information in investor relations. The perspective of corporate governance*, Wydawnictwo Uniwersytetu Gdańskiego, Gdańsk.

4. Brown N., Deegan C., (1998) .The public disclosure of environmental performance information. The agenda setting theory and legitimacy theory, *Accounting and Business Research*, Vol. 29.
5. Daszkiewicz M., (2007). *Impact of social relations on the market position of Polish enterprises*, Scientific Work AE No. 1170, Wrocław.
6. Donaldson T., Dunfee TW (1994). *Toward a unified conception of business ethics, Integrative social theory*, Academy of Management Review, Volume 19.
7. Frederick W. C, Davis D., Post JE (1988). *Business and Society. Corporate Strategy. Public Ethics*, McGraw-Hill Publishing Company, New York 1988.
8. Friedman M. (1970). *The New York Times Magazine*, New York, September 13, 1970.
9. Fuente, J. A. , García-Sánchez, IM and Lozano , MB (2016). The role of the CSR information. *Journal of Cleaner Production*, Vol. 141.
10. Guthrie J., Parker L., (1990). Corporate social disclosure practice: a comparative international analysis, *Advances in Public Interest Accounting 3* .
11. Harrison, JS and van der Laan Smith, J. (2015), Responsible accounting for stakeholders, *Journal of Management Studies*, Vol. 52 7.
12. Hobbs JE (2004). *Information asymmetry and the role of traceability systems*, Agribusiness An International Journal, Volume 20, Issue 4.
13. [http://odpowiedzialnybiznes.pl/wpcontent/uploads/2016/06/parp\\_PL\\_Raport\\_koncowy\\_2016\\_05\\_16\\_FIN.pdf](http://odpowiedzialnybiznes.pl/wpcontent/uploads/2016/06/parp_PL_Raport_koncowy_2016_05_16_FIN.pdf)
14. Kieso DE, Weygandt JJ (1995). *Intermediate Accounting*, 8th. Ed, Wiley, New York
15. Kubiak J. (2011). *Methods of testing information asymmetry in the enterprise in the field of capital allocation*, National Economy 236, Warsaw.
16. Lehman, G. (2017). The expression of beauty and truth. *Critical Perspectives on Accounting*, Vol. 44.
17. Morgan, G., (1988). Accounting as reality construction: towards a new epistemology for accounting practice. *Accounting, Organizations and Society*, Vol. 13 5.
18. Papaj E. (2016). *The directions of changes in non-financial reporting date in Poland*, reviewed Proceedings of the International Scientific Conference on MMK Masaryk 2016 International Conference for Ph.D. Students and Young Researches, MAGNANIMITAS, Czech Republic.
19. Skowroński A., (2005). *Impact of information asymmetry on financial decisions of enterprises*, The legal, economic and sociological movement, Zeszyty 3, Warsaw.
20. Stanton, P., Suttipun, M. (2012). Determinants of Environmental Disclosure in Thai Corporate Annual Reports. *International Journal of Accounting and Financial Reporting*, Vol. 2, No. 1.
21. Svenson G., Wood G., Callaghan M. (2010). A corporate model of sustainable business practices: An ethical perspective, *Journal of World Business* , Vol. 45.
22. Walińska M. (2015). *Integrated report - beginning of the end of the financial report?*, Accounting Theoretical Accounts Volume 82, Publishing House of Accountants Association in Poland, Warsaw.

## TECHNOLOGY, ORGANISATION AND STRETEGY AS THE TOOL TO OVERCOME NEGATIVE EXTERNALITIES

**Mario Lesina**

*Midal d.o.o., Croatia  
mario.lesina@gmail.com*

**Lovorka Gotal Dmitrovic**

*University North, Croatia  
lgotaldmitrovic@unin.hr*

**Marko Stojic**

*University North, Croatia  
marko.stojic@unin.hr*

### **ABSTRACT**

*Globalization forces companies to improve financial performance and system coordination trough new technology, new organization schemes and new strategic approach considering the changes caused by international environment and faster dialectic of time on global scale. Participation of manufacturing in Croatian GDP is showing very volatile trend but within time frame from year 2002. till 2017. it has grown and trend is still positive, although still very volatile. The main jeopardy that Croatian companies are exposed to is lack of labourers which is already very conspicuous and is to become even more in middle term because of negative demographic trends. The decision by companies to enter into a structural changes trough new strategic approach, considering new technologies and new organization schemes inquired by mentioned changes is influenced by the management`s decision and assessment how to maintain and improve company`s profitability and increase the productivity in order to compensate lack of labourers. In other words, companies are forced to use new strategy, technology and organization in order to maintain competitiveness on global scale. The main objective of this paper is to investigate how the companies are using new technologies and organization schemes in order to improve productivity and to create products at same price and better quality with increased cost. Moreover, a qualitative study among companies in manufacturing was conducted in order to get knowledge how the top management in Croatian companies understands the concept of modified strategic approach, new technology and modified organization and to determine factors for successful cost effective operating, and to investigate what impediments are the managers expecting and their predictions how to overcome them.*

**Keywords:** *Organisation, Strategy, Technology*

### **1. INTRODUCTION**

The initiative for this work is driven by the review of International meeting of Leather and Footwear Industry, held in Čakovec in year 2017. with the main topic «Industry 4.0 and it's appliance in Leather and Footwear Industry» where all of the participants have shown a large amount of knowledge about Industry 4.0 and high level of awareness about futures tendencies regarding such industry, and emphasised that, due the lack of skilled labourers and expected rise of wages, new organisational models and replacement of human labour with the automatized machines are the only possible way to increase productivity. Ghauri et al. (2003) concluded that networking models, outsourcing above all, helped developing countries in raising their competitiveness. In further researches, performed by Renko et al. (2104) was also confirmed that outsourcing was main model in revitalisation and development of leather and

footwear industry in Croatia. According to Croatian Ministry of Economy (2014, p 160) main advantages of Croatian companies was business tradition and skilled labourers, high level of quality, proximity to the European market that provides quick deliveries, high flexibility of production and lower level of wages then in the countries of Old Europe. Structure of Croatian footwear industry is shown in Table 1.

*Table 1: Structure of Croatian footwear industry*

Year	Total revenue in HRK	Number of employed	Companies by size			Total
			Small	Middle	Large	
2008.	2.364.973.135	8.583	114	9	1	124
2009.	2.182.539.018	7.692	115	8	1	124
2010.	2.556.027.748	8.781	116	10	1	127
2011.	2.957.739.973	9.026	120	8	1	129
2012.	3.000.752.156	8.547	122	7	1	130
2013.	3.071.295.472	9.787	123	4	1	128
2014.	3.772.515.477	10.611	126	3	2	132
2015.	3.784.711.035	10.411	129	3	2	134
2016.	3.401.438.851	10.350	130	3	2	135
2017.	3.383.979.845	9.996	132	5	2	139

Paper begins with theoretical framework where historical concept of Industrial Revolution, including 4-th Industrial Revolution. Industry 4.0 is topic of a whole series of current discussions, but there are lacking discussions with sectorial approach, especially in footwear industry. The objective of this paper is to stipulate the Croatian managers level of knowledge about Industry 4.0 and to stimulate further discussions and researches on a sectorial approach in order to propose possible ways to adopt Industry 4.0. Next section explains the methodology adopted and the discussion of cases of Industry 4.0 in the investigated industry. Follows an analysis of the findings of the qualitative research among managers of companies operating in the Croatian footwear industry is given. It ends with an integrated conclusion, summarising the results, developing managerial implications and providing suggestions for future research with the directions proposed.

## **2. THEORETICAL FRAMEWORK**

Globalism and globalisation entered everyday use in early 1960s after publishing marshal McLuhan's Gutenberg Galaxy, but in official use it has entered first in 1986 in second edition of Oxford English Dictionary. Globalisation is a process of emergence in the world of economy, cosmopolitan culture and international social movements (Albrow and King 1990). Malcom Waters defined it as «process in which the constraints of geography on social and cultural arrangements recede and (as the consequence) people become increasingly aware that (such constraints) are receding (Waters, 1995) According to Wiegerling (2004: 2), globalisation as a global integration of markets and the consideration of a local identity can exist side by side. Ekonomski leksikon (2011) defines globalization as the process of tighter connecting and mutual interdependence among the parts of the modern world fuelled by constant growth of scope and importance of the international trade trough exchange of consuming goods, capital, technology and knowledge. As we can see, definition of globalisation is different by size and scope since first mentioned definition to now days' definition of it. Globalisation describes a process by which national and regional economies, societies, and cultures have become integrated through the global network of trade, communication, immigration and transportation. However, globalization is much more than just trade. It includes all aspects of life and determinates all of the development processes, with special emphasising on economy in general.

Preglobalised economies used to be based on domestic market and the neighbouring markets or markets nearby. One of the reasons for such condition surely was geographical distance. The main point of the Second industrial revolution was appliance of the internal combusting machines in transportation, such as steam turbine, in maritime transportation, or gas (four-stroke) engine in road vehicles (Bryant, 1967). Both of those inventions have relativized geographical distance trough enabling to reach desired destination in less time at lower costs. International trade became more important. Two World wars and the time between them, marked by Great depression, disrupted trends and tendencies, but the sequel of them followed after 1950. which is marked as the end of post war reconstruction and rebuilding process (Pollard 1986). After 1950. international trade became the main sector of all economies, as shown in Table 2.

*Table 2: Exporting within 70 years*

Country	Austria	Belgium	Denmark	Germany	Italy	Sweden	UK
1918.	100	100	100	100	100	100	100
1950.	32	112	240	35	127	276	100
1973.	5.339	886	1.115	514	1.619	1.298	242

*Source: Madisson (1998, 138)*

Structure of the international trade also changed in globalised world. Before globalisation, developed countries used to import agricultural products and row materials, and in globalised world their import shifted to industrial products. On the other side, developed countries in non-globalised world exported industrial products and food, and now, in globalised world they are exporting technology, knowledge and capital, as shown in Figure 1.

*Figure 1: International trade in pre-globalised and globalised world*

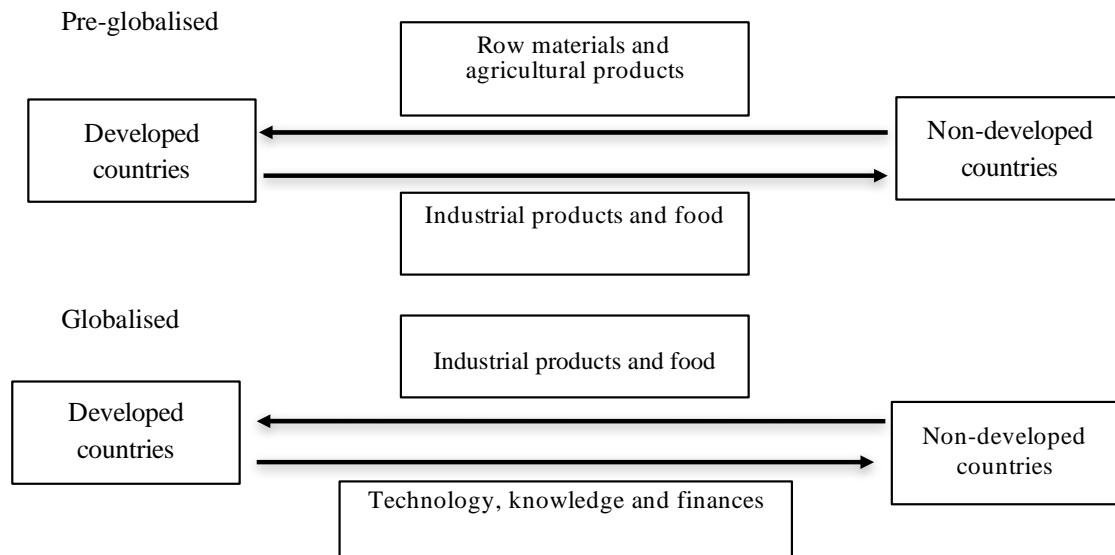

□

*Source: based on Dicken, P. Global Shift, Gilford Press, New York, London; 2003, p. 9*

Tylecote (1992) defined the invention of computer and internet in early 1970-ies as the beginning of the third industrial revolution. Computers made possible to automatize whole factories, and internet made possible to exchange information's and knowledge easier and faster and world have become "Global village". Great stimulus to intensification of international trade where also political actions taken after 1950. in order to restrict the boundaries among the countries.



The most significant of them was founding of GATT – General Agreement on Tariffs and Trade in October 1947. among 23 countries. This agreement allowed signatories to approach each other's markets as the most-favoured nation, in the other words, each on signatory country are applying such status even doe they did not negotiated and agreed directly. In further two rounds, Kennedy in 1964. and Tokyo in 1973, further liberalisation has been made, and finally, after Uruguay round of negotiations in 1995. GATT turns into WTO (World Trade Organisation) and the world turns into one single market with no boundaries or trade restriction. All the members of WTO, now 164 of them, should be not discriminated, more open, transparent, competitive, and WTO should bring more benefits to less developed members. Process of globalisation together with technical advancing and development brought to job polarisation (Goos and Manning, 2009). Job Polarisation is a process in which middle-skill jobs are decreasing, and low-skill and high skill jobs are increasing. This phenomenon is caused by replacement of human labour by machines (Frey and Osbourne, (2013), but also transfer of middle-skilled jobs to less developed countries (Gereffi and Sturgeon, 2004). First such transfer of labour, also known as outsourcing (Lei and Hitt, 1995), appeared in clothing industry, including footwear industry in years 1950-1960, as this industry was displaced to Japan, later on, in years 1970-1980 from japan to Hong Kong, South Korea, Taiwan and Singapore, after that from, in years 1980-1990 from Hong Kong, South Korea, Taiwan and Singapore to China, Indochina and Bangladesh, and from Old Europe to New Europe (Gereffi 1999). Trend of labour migration among sectors is shown in Table 3.

*Table 3: Transformation of the national economies, global shift*

<b>Year</b>	<b>1950</b>			<b>1973</b>			<b>2000</b>		
<b>Region</b>	Western Europe	Southern Europe	Central and eastern Europe	Western Europe	South Europe	Central and eastern Europe	Western Europe	Southern Europe	Central and eastern Europe
<b>Services</b>	36,30	27,30	36,90	47,60	37,00	35,70	68,70	60,70	52,90
<b>Industry</b>	40,80	24,20	34,00	43,40	34,90	37,80	28,40	30,20	29,10
<b>Agriculture and mining</b>	22,90	48,50	29,10	9,00	28,10	26,50	2,90	9,60	18,00

*Source: Berend I.T. Ekonomska povijest Europe dvadesetog stoljeća, Zagreb, Mate 2011.*

Further technological development brought to the fourth industrial revolution or industry 4.0 (Schwab 2109). The aim is no longer to replace human physical labour, or to support humans in performing work, but to replace cognitive work and humans together based on key technologies, such as genetics, artificial intelligence, cloud computing, nanotechnology, biotechnology, and 3D printing, among others. Brynjolfsson and McAfee (2014) claimed that technological progress is advancing with exponential speed and that we are currently just at the beginning of fundamental changes and technological breakthroughs that are yet to occur in the next few decades. Possibility of mining, processing, systematizing and analyzing of large amount of different data, provided by mighty hardware and software, have enabled the whole new approach in defining organization schemes, strategical decision making and technology appliance. Among wide variety of management programs developed and applied in order to enhance competitiveness, most popular programs still are Six Sigma and Lean management. Program Six sigma is first introduced by Bill Smith (Tennant, 2001). Breafly, Six Sigma is the need for quality improvement when manufacturing complex products having a large number of components, which often resulted in a correspondingly high probability of defective final

products. Combining Total Quality Control (TQC) and Six-Sigma statistical metric originating at Motorola Company. Today, Six Sigma is a broad long-term decision-making business strategy rather than a narrowly focused quality management program (Arnheiter and Maleyeff, 2005). Lean management originates from Toyota production system set by Taiichi Ohno and Shigeo Shingo (Inman, 1999). Lean management refers to reduce resource waist, not material nor human. According to this model, waste is to be eliminated in the way that all activities along the value stream are made perfectly in order to generate perfection at the end. Each process is about to start with initial rethinking each time again in order to deliver improvements and reduce waist. Lean management does not presume no quality control at all, it relies on labourers themselves to control their own work and performance (Womack and Jones, 1996). Now days, Lean management does not refer only on production, as originated, but also on management. Process starts with "Kaizen", rethinking of process, continues with "Kaikaku" action, more or less radical, to improve the process and result is elimination of "Muda", waste on Japanese. The lean production goal of eliminating waste (muda in Japanese), so that all activities along the value stream create value, is known as perfection. Efforts focused on the reduction of waste are pursued through continuous improvement or kaizen events, as well as radical improvement activities, or kaikaku. Both kaizen and kaikaku reduce muda, although the term kaikaku is generally reserved for the initial rethinking of a process. Hence, perfection is the goal and the journey to perfection is never ending (Womack and Jones, 1996). Considering that Six sigma concentrates on waste reduce through rough control using statistical methods in order to predict weak loops in chain and to observe them, and Lean management concentrates on reducing resource wastage, it is logical to conclude that those two models can and should be combined with each other. Such models are called Lean Sigma (Sheridan, 2000).

### **3. METHODOLOGY**

In order to increase knowledge about negative externalities in globalised world, several information sources and scholarly databases Emerald, Ebsco and ProQuest have been consulted which brought us to identification of words: Organisation, Strategy and Technology at the key words. In order to detect what externalities are main threat to footwear industry in Croatia, and to conclude whether or not Croatian managers have vision how to overcome them, authors performed semi conducted in depth interview with five managers of the leading Croatian footwear companies. Qualitative approach is chosen in order to utilise insider position of authors and to gain deep idiographic cognition and to create new theoretical framework (Byrman, 1988). Even do the sample is so small, saturation have been accomplished because selected companies are consisting more than 50% of total number of employed, and more than 50% of the revenue what makes the sample sufficient (Huges, 1999). In order to conduct the interview, authors have used reminder with two general questions to keep up with theoretical part of the paper. All of the managers were interviewed together in opened, less formal, atmosphere the whole afternoon, about four hours.

### **4. RESULTS**

This section includes the discussion about main challenges in Croatian footwear industries what future brings and about methods of solving the problems brought by negative externalities in order to gain insights into the opportunities in the time to come. All five of the Croatian top managers are inquired to answer two main questions. What are the main negative externalities who are affecting the business and how they see the solutions that should enable maintenance of competitiveness and further development? Plain nature of footwear production is a batch and queue process with large number of different operation which are performed sequentially regardless are they needed for next operation (Wong and Hammond 1991). According to all interviewed managers in footwear industry, labour costs are about 25% of total costs, and

therefore optimal utilisation of working hours, working efficiency, is one of the mayor criterion for valuation of companies' success. The main task of the production management is to organise the production process in the way to use working hours optimally, to maintain and improve demanded quality level and to keep up with the delivery deadlines inquired by end consumers. In order to make this coordination possible, first loop in the supply chain, the logistic, needs to operate with the interests of their own firms (Ryu et al, 2009), and such model demands complex interactions of people, materials, equipment, and resources. In this model timing is everything. As all of the managers emphasised, disruptions in supply chain are the constant treat to companies functioning, but also to companies vitality because such disruption in supplying with the materials need for production are causing large disruptions in production itself, which is impossible to overcome without significant costs. Disruption in supplying causes delay in delivery, which is very often penalised directly with certain financial fee, or indirectly through declined orders in time to come. Speeding up the production in order to compensate time lost, either through overtime or pushing forward some items (orders) causes declined quality and further chaos in batches cumulated in production process. In order to avoid such disruptions in supply chain, rethinking of the optimal supplier needs to be nonlinear and it needs to consider more elements than price (cost) in decision making, such as quality, punctuality and reliability (Lešina, 2013). As the opportunity managers are emphasising the seasonality of the production process. All the products are sold six months in advance, practically, "Made to Order" (MTO) products (Sheridan, 2000), what gives the opportunity to organize and coordinate the supply chains in optimal way. This brings us to situation in which we have necessity for batches in production as the supposition for optimal utilisation of working hours for production of MTO products. This gives the opportunity to reduce use of spatial resources, for storage of so many different material, financial resources for purchasing them human resources to operate with them because the supply chain takes over large amount of regular stockman's jobs and reduces number of labourers. Further managers emphasising was strategical approach to bind closely to suppliers and to integrate inner processes with each other in order to gain the best and the shortest delivery terms with them. As negative externalities managers are alleging strong migration of labourers abroad and in other industries due better wage, lack of skilled young labourers to replace the retired ones and low level of interest for the industry in general, not only the footwear industry. Those negative externalities are mutually intersecting so the managers are seeing the solution in raising wages. According to Croatian Chamber of Commerce (2017) average wage in footwear industry are 68% of average wage in manufacturing industry and 62% of general Croatian average wage. Higher wages would keep the labourers within the industry and generate interest for the young people, but, is it so simple and easy? Footwear industry is oriented mainly to exports considering the fact that the interviewed companies are exporting more than 90% of its products, and linear, one sided raise of the product prices would generate decline of competitiveness and decline of orders as well. Such decline of orders would increase share of fixed costs in the price structure of the product, what would invalidate positive effect of price increase. Other possibility is to rise the wages by reducing profit. Such operation would make impossible to make any development projects, including refurbishment of technology, not to mention investments in new technology, and, in the long term, it would make the company uncompetitive and unable to respond the market inquiries and demands. The only way to resolve problem they are faced with, managers are seeing in increment of productivity. Tools to do it are constant improvement of the production process and replacement of human labour with machines. Now days' production process is based on interaction of humans and machines, but in the near future is, according to them, necessary to increase share of machine work on behalf of human work. Such shift would diminish significance of human skills and resolve the lack of technologically educated and skilled labourers. Inclusion of new labourers in the process would be far easier. In order to make it possible, managers ate emphasising the importance of strong interaction with scientific institutions, but also significance

of support by the state because they are not able to manage it alone. Scientific institutions are important because the performance of robotized machines are not yet at the satisfying level, and they need to be improved. Significance of the state is actually in incentives. Beside direct costs of purchasing new technology, there are hidden, indirect, costs of its implementation regarding education of labourers. Managers are considering that such amount of costs would be unbearable for them alone, without outside help. As the positive cases, they assert cases of Portugal and Spain in years 2000.

## 5. CONCLUSION AND FUTURE RESHEARCH DIRECTIONS

Relaying on information gained through in-depth interview, these paper pints to following conclusions:

- Croatian footwear industry is applying mixture of batch-and-queue model, lean management for managing the supply chains.

Nature of production process demands batches in production in order to utilize the working hours and avoid losses in human resources measured in time units. Such approach demands lots of material at disposal, in the other words, inquires lots of the resources to be engaged, what is typical for batch-and-queue model. On the other side, all of the companies are strategically cooperating with the suppliers to coordinate inner organisation schemes and reduce the delivery time in order to reduce engagement of resources, what, basically is core of Lean management model. Lean management consists of three elements: Kaizen, Kaikaku and Muda (Womack and Jones). Kaizen element is detected in constant rethinking about suppliers and their performance in the sense of constant improvements, what leads to Kaikaku, actions towards supplier in order to coordinate activities, and both in order to avoid Muda (waist). Considering supply chain, Muda are disruption in production process caused by lack of needed raw or semi-produced materials.

- To manage production, Croatian footwear companies are applying mixture of Six sigma and Lean management model.

One of the main comparative advantages of Croatian footwear producers, according to Croatian Ministry of Economy, is high quality level. Such hypothesis is confirmed by Croatian mangers in footwear industry. All of the interviewed managers stated that there are persons employed in all of the production phases with the main task to control quality. Here is important to mention that footwear production is a two-stage production systems (Tone and Tsutsui, 2009), where all outputs from the first stage are intermediate products that make up the inputs to the second stage, in case of footwear production, uppers, for which input large amount of different materials is, input for mounting are. Those two stages have very little common. Hence, elements of Six Sigma are detected here. Another of the main comparative advantages, also according to Croatian Ministry of Economy and all of the interviewed managers, is quick delivery. In order to provide such deliveries, production process must be as short as possible. Here we are faced with one dichotomy. Batch-and queue model is perfect to utilize the working hours optimally, but it does not give priority to short delivery terms. On the other side, consumers are demanding short delivery terms, and Croatian footwear companies are using such demands as their comparative advantage amongst other companies. So, the companies must deliver goods quick without generating disruptions in working hours or idling due to giving priority to certain orders in production. In order to do so, management plans the production considering delivery terms, but also considering necessary batches in production with less queues –Kaizen, management also predicts possible deadlocks in production along with the actions to be done in case of deadlocks-Kaizen. Deadlocks are Muda in this case. Hence, Lean Management is also detected. It is to be concluded that Croatian footwear companies are capitalising strengths of both, Lean Management

and Six Sigma to maintain and improve market position, precisely, they use three primary tenets of lean management: incorporating an overriding philosophy that seeks to maximize the value-added content of all operations, incorporating a management decision-making process that bases every decision on its relative impact on the customer and constant evaluation of all incentive systems in place to ensure that they result in global optimization instead of local optimization. Three primal tenets of Six Sigma included in Croatian footwear companies are: data-driven methodology in decision making, so that changes are based on scientific rather than ad hoc studies, promotion of methodologies that strive to minimize variation of quality and implementation of a company-wide and highly structured education and training regimen. Final conclusion is that interviewed Croatian footwear are applying Lean Six Sigma organization, as Arnheiter and Maleyeff (2005) defined.

- Croatian managers consider Industry 4.0 as the only way to overcome negative externalities in the time to come

All of the interviewed managers stated that all of them have already problems with labourers in general. Larger picture is even worse considering that population of Croatia is declining. Forecast is to be under four million in year 2020. Another great problem that Croatian economy in general is facing is faster growth of wages than productivity, nay, trends are opposite, productivity is declining and wages are growing as shown in Picture 2.

*Picture 2: Discrepancy between growth of wages and productivity*

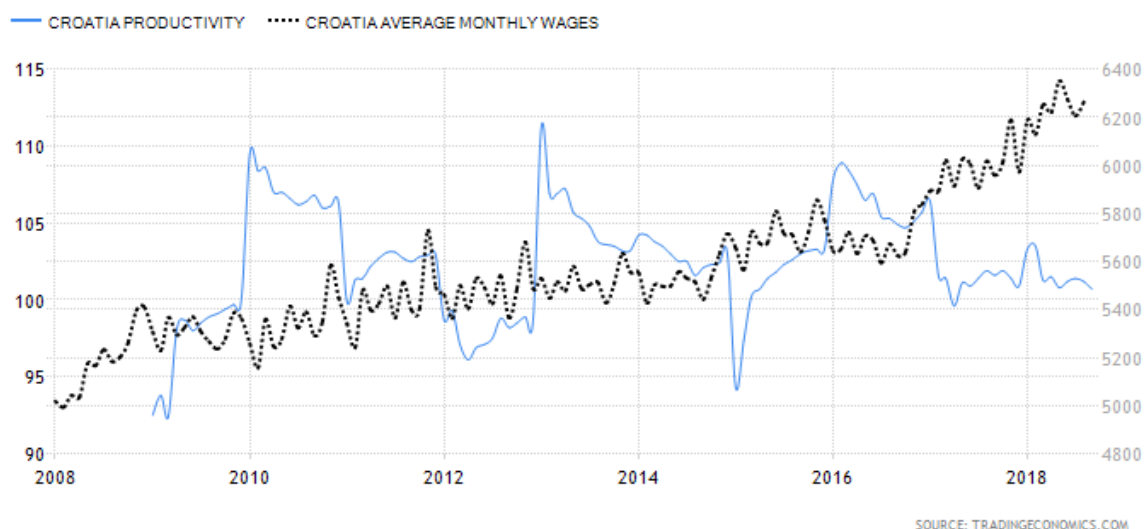

Replacing human labour with the machines would resolve all mayor problems and maintain, or even improve competitiveness. Faced with the fact that labourers are migrating in other industries, with the job polarisation and extinction of middle-skilled jobs, and the fact that the wages will grow further on towards EU average regardless to productivity growth, automatization seems as the only possible solution. Despite some rather pessimistic views (Ford, 2015) who are concerned about vast job loss after significant appliance of automatization in production, there is a general consensus among labor economists that mass unemployment is unlikely to be a major problem in the next few decades. Arntz et al. (2016) estimated that 9% of all individuals in the United States are working in a job that has high potential for automation, with at least 70% of performed tasks being automatable based on current technology.

## LITERATURE:

1. Albrow, M., King, E. *Globalization, Knowledge and Society: Readings from International Sociology* SAGE, 1. August 1990 pp 1
2. Arnheiter E. and Maleyeff J. *The TQM Magazine* Vol. 17 No. 1, 2005 pp. 5-18 q Emerald Group Publishing Limited
3. Arntz, M., T., Gregory, & Zierahn, U. (2016). *The risk of automation for jobs in OECD countries: A comparative analysis* *OECD Social, Employment and Migration Working Papers*. Paris: OECD Publishing.
4. Berend I.T. *Ekonomska povijest Europe dvadesetog stoljeća*, Zagreb, Mate 2011.
5. Bryant, L. 1967. "The Beginnings of the Internal Combustion Engine." In *Technology in Western Civilization*. Vol. 1, edited by Melvin Kranzberg and Carroll W. Pursell, Jr., 648-663. New York: Oxford University Press.
6. Bryman, A. (1988). *Quantity and Quality in Social Research*. London: Unwin Hyman.
7. Brynjolfsson, E., & McAfee, A. (2014). *The second machine age : work, progress, and prosperity in a time of brilliant technologies*. New York: W. W. Norton & Company.
8. Dicken, P. *Global Shift*, Gilford Press, New York, London; 2003, p. 9
9. *Ekonomski leksikon*, Leksikografski zavod Miroslav Krleža, Zagreb 2011. ISBN 978-953-260-013-3
10. Ford, M. (2015). *Rise of the robots technology and the threat of a jobless future*. New York: Basic Books.
11. Frey, C. B., & Osborne, M. A. (2013). *The future of employment: How susceptible are jobs to*
12. Gereffi, G. i Sturgeon, T. J. (2004). *Globalization, Employment and Economic Development: a Briefing Paper*. Sloan Workshop Series in Industry Studies, Rockport, MA, lipanj, 14–16.
13. Ghauri, P.N. and Prasad, B. (1995), "A network approach to probing Asia's interlinkages," *Advances In International Comparative Management*, Vol. 10, pp. 63-77
14. Goos, M., Manning, A., & Salomons, A. (2009). *Job polarization in Europe*. *American Economic Review*, 99(2),
15. <http://www.britannica.com/topic/General-Agreement-on-Tariffs-and-Trade>,
16. <https://tradingeconomics.com/croatia/productivity>
17. [https://www.wto.org/english/docs\\_e/legal\\_e/marrakesh\\_decl\\_e.htm](https://www.wto.org/english/docs_e/legal_e/marrakesh_decl_e.htm)
18. [https://www.wto.org/english/thewto\\_e/minist\\_e/min96\\_e/chrono.htm](https://www.wto.org/english/thewto_e/minist_e/min96_e/chrono.htm)
19. [https://www.wto.org/english/thewto\\_e/whatis\\_e/what\\_stand\\_for\\_e.htm](https://www.wto.org/english/thewto_e/whatis_e/what_stand_for_e.htm)
20. Hughes, A. (1999). *Constructing Economic Geographies from Corporate Interviews: Insights from a Cross-Country Comparison of Retailer-Supplier Relationships*. *Geoforum*, 30, 363–74.
21. Hymer S. , *International Economics Policies and their Theoretical Foundations*; Ch.: *The Tokyo Round of multilateral trade negotiations (1973–79)* Elsevier, 1982, ISBN 978-0-12-444280-1
22. Inman, R.R. (1999), "Are you implementing a pull system by putting the cart before the horse?", *Production and Inventory Management Journal*, Vol. 40 No. 2, pp. 67-71
23. Lei, D., Hitt, M. A. (1995). *Strategic restructuring and outsourcing: the effects of mergers and acquisitions and LBOs on building firm skills and capabilities*. *Journal of Management*, 21 (5), 835–859.
24. Lesina M. (2013) »Business Interligence in Industry« *IMR IX*, ISBN 978-953-253-117-6 Opatija p. 239-248
25. Maddison, A. (1998) ; *The World Economy in the 20th Century*; Paris: OECD, 138.
26. *Ministry of Economy Republic of Croatia (2014), Croatian Industrial strategy 2014-2020*, January 2014, Zagreb

27. Pollard, S. (1986). *Peacefull Conquest. The Industrialisation of Europe 1760-1970*. Oxford: Oxford University Press.
28. Renko, S., Grilec, A., Lešina, M. (2014). Dealing with crisis: using subcontracting for the development of the Croatian leather manufacturing and processing industry. 10<sup>th</sup> Interdisciplinary Management Research (IMR) Conference, 469–480.
29. Ryu, I., So, SH, Koo C. (2009), The role of partnership in supply chain performance, *Industrial Management i Data System*, 109, 4, pp 496-514.
30. Schwab, K. (2016). *The fourth industrial revolution*. New York: Crown Business.
31. Sheridan, J.H. (2000), "Lean Sigma synergy", *Industry Week*, Vol. 249 No. 17, pp. 81-2.
32. Tennant, G. (2001). *SIX SIGMA: SPC and TQM in Manufacturing and Services*. Gower Publishing, Ltd. p. 6. ISBN 0-566-08374-4
33. Tylecote, A., 1992. *The Long Wave and the World Economy: The Current Crisis in Historical Perspective*. Routledge, London.
34. Waters, M., *Globalisation*, Roitledge, London February 1995
35. Wiegerling, K., (2004), "Localisation versus Globalisation – Claim and Reality of Mobile and Context-aware Applications of the Internet", in: *International Center for Information Ethics (ICIE)*, Volume 2, 1-7.
36. Womack, J.P. and Jones, D.T. (1996), *Lean Thinking*, Simon & Schuster, New York, NY, pp. 90-8.
37. Wong, A. and Hammond, J.H. (1991), *Dore´ -Dore´*, Harvard Business School Publishing, Cambridge, MA

## DISPARITIES IN DEVELOPMENT BASED ON TAXONOMIC RESEARCH – THE CASE OF SELECTED LATIN AMERICAN COUNTRIES

**Iwona Pawlas**

*University of Economics in Katowice, Poland  
iwona.pawlas@ue.katowice.pl*

### **ABSTRACT**

*Economic development is a multidimensional category, including not only quantitative changes expressed by indices of economic growth but also qualitative changes in socio-economic structure of a national economy. It is broadly accepted that economic development constitutes a key category describing economic structure of contemporary world economy. Improvement of life quality is considered one of crucial development challenges. Economic development is determined by numerous internal and external, economic and non-economic factors. Discussions regarding stimulants and barriers of economic development, as well as development disparities and the ways adopted for their measurement can be found in scientific literature. The problem of possible ways and methods of overcoming negative effects of 2008+ global crisis arouses considerable interest of researchers. The main goal of the paper is to examine and evaluate disparities in development of ten Latin American countries. The economic development of the following economies was analysed: Argentina, Bolivia, Brazil, Chile, Colombia, Ecuador, Guatemala, Mexico, Peru and Venezuela. Because of the complexity of the category of economic development, many elements had to be taken into consideration during the comparative study. The following diagnostic variables were taken into account: GDP growth, GDP per capita, share of service sector in GDP creation, inflation rate, unemployment rate, general government deficit, general government gross debt, infant mortality rate and life expectancy. Selected taxonomic methods were used, and in particular classification and hierarchization methods. Multidimensional comparative analysis resulted in identification of economies in the best economic condition and the worst one. Additionally, the analysed countries were classified into four classes in terms of synthetic measure of economic development. Moreover, the scale of income inequalities in the analysed economies was presented. Finally, international competitiveness of studied Latin American economies was presented.*

**Keywords:** *Latin America, development, taxonomic research, multidimensional comparative analysis*

### **1. INTRODUCTION**

The position of a national economy in a globalised world economy is strongly related to the level of its socio-economic development. More developed economies build stronger international relations, while countries characterised by lower level of development are usually less internationalised. Pro-development activities and pro-development policies aim at reducing poverty and increasing standard of living. Moreover, a higher level of development constitutes an important element of creating higher and more sustainable international competitiveness of a national economy. Unprecedented intensity and dynamism of globalisation has been observed in the 21<sup>st</sup> century. Global financial and economic crisis 2008+ has complicated the overall picture of the world economy. A really high and still rising interconnectedness in the globalised world economy creates necessity to study, observe, analyse and interpret phenomena and processes in each part of the World. The main objective of the paper is to explore, evaluate and diagnose disparities in development of selected Latin American economies. The economic development of the following ten Latin American countries was analysed: Argentina, Bolivia,



Brazil, Chile, Colombia, Ecuador, Guatemala, Mexico, Peru and Venezuela. Due to the complexity of a category of economic development, it was necessary to take into consideration a number of factors. Therefore, nine diagnostic variables were used, in particular:  $X_1$  - GDP dynamics,  $X_2$  - GDP per capita (PPP),  $X_3$  - service sector in GDP creation,  $X_4$  - unemployment rate,  $X_5$  - general government deficit (% GDP),  $X_6$  - general government gross debt (% GDP),  $X_7$  - life expectancy at birth,  $X_8$  - infant mortality (per 1000 life births),  $X_9$  - inflation rate. All diagnostic variables were divided into two groups: stimulants (*stimuli*) and destimulants (*destimuli*). GDP dynamics ( $X_1$ ), GDP per capita ( $X_2$ ), share of service sector in GDP creation ( $X_3$ ) and life expectancy at birth ( $X_7$ ) were considered stimulants. Unemployment rate ( $X_4$ ), general government deficit ( $X_5$ ), general government gross debt ( $X_6$ ), infant mortality ( $X_8$ ) and inflation rate ( $X_9$ ) were treated as destimulants. Initially it was planned to use two more diagnostic variables, namely gross expenditure on research and development (% GDP) and number of patents granted (per 10000 population) but it was not possible to gather the statistical data for all ten studied economies. The research was conducted for the year 2017. Statistical material provided by Central Intelligence Agency and taken from the World Factbook was used for the analysis. Due to the significance of family income inequalities, Gini index for the studied Latin American countries was analysed. In addition to that, the analysed ten Latin American economies were compared in terms of their competitive positions according to the Global Competitiveness Reports published by World Economic Forum.

## 2. RESEARCH METHODS

The research methods applied in the research included literature studies, descriptive analysis and taxonomic analysis. Because of a complexity of an economic category of economic development, chosen taxonomic methods were implemented. Hellwig's method of taxonomic measure of development as well as standard deviations' method were used. Hellwig's method of multidimensional comparative analysis made it possible to make a hierarchy of the studied subjects, i.e. ten Latin American economies, regarding synthetic measure of socio-economic development. After selecting the set of diagnostic variables, the character of each of variable was determined. Variables were standardized and development model was constructed – a model unit, where diagnostic of variables were determined according to the rule, where:

$$z_{0j} = \max_i (z_{ij})$$

for stimulants or

$$z_{0j} = \min_i (z_{ij})$$

for destimulants.

The distance of  $i$ -unit from the development model was calculated using Euclid's measure:

$$d_{oi} = \sqrt{\sum_{j=1}^m (z_{ij} - z_{oj})^2}$$

Taxonomic measure of development (TMD) was calculated according to the formula (Hellwig 1990; Hellwig 1968; Pluta 1977; Nowak 1990):

$$TMD_i = 1 - \frac{d_{oi}}{d_o}, i=1,2,\dots,n$$

where:

$$d_o = \bar{d}_o + 2S_o$$

and:

$$\bar{d}_o = \frac{1}{n} \sum_{i=1}^n d_{oi}$$

$$S_o = \sqrt{\frac{1}{n} \sum_{i=1}^n (d_{oi} - \bar{d}_o)^2}$$

while:

$$TMD_i \in <0; 1>, i=1, 2, \dots,n.$$

Finally, the analysed subjects were put in order according to the level of development expressed by taxonomic measure of development (TMD). Additionally, the implementation of cluster analysis for the research resulted in grouping of the analysed subjects – ten Latin American economies – in four clusters according to the level of socio-economic development measured by TMD. A selected method of grouping of linearly ordered objects, and in particular, method of standard deviations was used for this purpose. Ten selected Latin American economies were divided in four clusters, according to the following rule:

$$G_1 : s_i < \bar{s} - S(s),$$

$$G_2 : \bar{s} > s_i \geq s_i - S(s),$$

$$G_3 : \bar{s} + S(s) > s_i \geq \bar{s},$$

$$G_4 : s_i \geq \bar{s} + S(s),$$

where:  $\bar{s}$  - arithmetic mean of synthetic variable (in this study: arithmetic mean of TMD), while  $S(s)$  - standard deviation of synthetic variable (in this study: standard deviation of TMD),  $s_i$  - value of the synthetic variable of the object  $i$  (in this study: TMD value in  $i$  Latin American economy).

### 3. PRESENTATION OF INPUT DATA AND RESEARCH RESULTS

As it was mentioned before, the research embraced ten Latin American countries. They were selected by population and territory. Altogether they represented over 552.8 million people and area of 18.85 million square kilometres. Table 1 presents the set of statistical data used during the research:  $X_1$  - GDP dynamics,  $X_2$  – GDP per capita according to purchasing power parity (PPP in Int. \$),  $X_3$  – service sector in GDP creation (%),  $X_4$  –unemployment rate (%),  $X_5$  – general government deficit (% GDP),  $X_6$  – general government gross debt (% GDP),  $X_7$  – life expectancy at birth (years),  $X_8$  – infant mortality (per 1000 life births),  $X_9$  – inflation rate (%).

Before the fundamental taxonomic analysis could begin, the situation in ten selected Latin American countries in regard to all nine diagnostic variables one by one was studied.

This initial stage of research has led to the following conclusions:

- GDP dynamics ranged from +4.2% (Bolivia) to minus 12% (Venezuela) with an average amounting to 0.63%;
- Maximum level of GDP per capita (PPP) was noted in Chile (24600 Int. \$), minimum level of GDP per capita (PPP) was observed in Bolivia (7500 Int. \$), and an average GDP per capita (PPP) equalled 14730 Int. \$;
- The share of service sector in GDP creation ranged from 54.1% in Bolivia to 72.8% in Brazil, with an average amounting to 61.39%;
- The lowest level of unemployment was observed in Guatemala (2.3%) and the highest unemployment rate was characteristic for Venezuela (26.4%), while an average rate of unemployment for the studied group of Latin American economies amounted to 8.56%;
- General government deficit ranged from 1.1% GDP in Brazil to 38.1% GDP in Venezuela, and an average level of general government deficit in the analysed states equalled 7.13% GDP;
- Minimum level of general government gross debt in relation to GDP was noted in Guatemala (24.4% GDP) and maximum level of general government gross debt in relation to GDP was observed in Brazil (78.4% GDP); it is worth mentioning here that the average government gross debt for the studied states amounted to a bit over 43% GDP;
- Average life expectancy at birth equalled 75.13 years, with its maximum observed in Chile (78.9 years) and its minimum noted in Bolivia (69.5 years);
- Infant mortality ranged from 6.6 ‰ in Chile to as much as 35.3 ‰ in Bolivia, with average infant mortality for the analysed group of countries amounting to 16.27 ‰;
- The lowest inflation rate was observed in Ecuador (0.7%) and the highest rate of inflation was noted in Venezuela (653.2%), and average inflation rate for the studied Latin American economies equalled 70.73%.

*Table 1: Set of statistical data (CIA, 2018)*

Economy	Input data								
	X <sub>1</sub>	X <sub>2</sub>	X <sub>3</sub>	X <sub>4</sub>	X <sub>5</sub>	X <sub>6</sub>	X <sub>7</sub>	X <sub>8</sub>	X <sub>9</sub>
Argentina	2.5	20700	60.9	8.1	6.1	53.7	77.3	9.8	26.9
Bolivia	4.2	7500	54.1	4.0	6.2	51.5	69.5	35.3	3.2
Brazil	0.7	15500	72.8	13.1	1.1	78.4	74.0	17.5	3.7
Chile	1.4	24600	64.3	7.0	3.1	25.2	78.9	6.6	2.3
Colombia	1.7	14500	61.4	9.3	3.3	53.0	75.9	13.6	4.3
Ecuador	0.2	11200	59.7	5.1	5.5	41.0	77.0	16.4	0.7
Guatemala	2.8	8100	63.2	2.3	3.2	24.4	72.6	21.3	4.4
Mexico	2.1	19500	64.0	3.6	1.9	51.5	76.1	11.6	5.9
Peru	2.7	13300	56.1	6.7	2.8	25.7	74.0	18.4	3.2
Venezuela	-12.0	12400	57.4	26.4	38.1	25.8	76.0	12.2	652.7

*Table following on the next page*

Table 2: The results of input data sorting (Own calculations)

Economy	Input data								
	X <sub>1</sub>	X <sub>2</sub>	X <sub>3</sub>	X <sub>4</sub>	X <sub>5</sub>	X <sub>6</sub>	X <sub>7</sub>	X <sub>8</sub>	X <sub>9</sub>
Argentina	4	2	6	7	8	9	2	2	9
Bolivia	<b>1</b>	<b>10</b>	<b>10</b>	3	9	7	<b>10</b>	<b>10</b>	4
Brazil	8	4	<b>1</b>	9	<b>1</b>	<b>10</b>	7	7	5
Chile	7	<b>1</b>	2	6	4	2	<b>1</b>	<b>1</b>	2
Colombia	6	5	5	8	6	8	6	5	6
Ecuador	9	8	7	4	7	5	3	6	<b>1</b>
Guatemala	2	9	4	<b>1</b>	5	<b>1</b>	9	9	7
Mexico	5	3	3	2	2	7	4	3	8
Peru	3	6	9	5	3	3	7	8	4
Venezuela	<b>10</b>	7	8	<b>10</b>	<b>10</b>	4	5	4	<b>10</b>

The results of the procedure of input data sorting were presented in table 2. A relatively good situation was easily visible in the case of Chile: the Chilean economy took the 1<sup>st</sup> position in terms of variables X<sub>2</sub>, X<sub>7</sub> and X<sub>8</sub>, moreover it was classified on the 2<sup>nd</sup> positions in regard to variables X<sub>3</sub>, X<sub>6</sub> and X<sub>9</sub>. The opposite situation was observed in case of both Venezuela and Bolivia: they were positioned on the very last place in regard to four variables: Venezuela took the very last position in terms of X<sub>1</sub>, X<sub>4</sub>, X<sub>5</sub> and X<sub>9</sub>, while Bolivia was classified on the 10<sup>th</sup> place in regard to X<sub>2</sub>, X<sub>3</sub>, X<sub>7</sub> and X<sub>8</sub>. Table 3 presents the results of research with the application of Hellwig's method of taxonomic measure of development (TMD). TMD ranged from 0.792 in case of Chile (the unquestionable leader in regard to socio-economic development among the ten studied Latin American countries) to 0.127 for Venezuela (the least developed one). The top-three group included also Mexico (TMD for Mexico equalled 0.690) and Argentina (with TMD amounting to 0.649). It is worth mentioning here that TMD for Venezuela represented 16% that of Chile.

Table 3: Ranking of selected Latin American countries according to taxonomic measure of development (Own calculations)

Position	Economy	TMD
1	Chile	0.792
2	Mexico	0.690
3	Argentina	0.649
4	Colombia	0.582
5	Ecuador	0.552
6	Brazil	0.500
7	Peru	0.496
8	Guatemala	0.484
9	Bolivia	0.210
10	Venezuela	0.127

As a result of the adoption of cluster analysis, ten Latin American countries were divided into four clusters G<sub>1</sub>, G<sub>2</sub>, G<sub>3</sub> and G<sub>4</sub>. G<sub>4</sub> included the economies for which  $s_i$  amounted to at least 0.712 (i.e. the most developed ones); G<sub>3</sub> gathered the economies which were characterised by  $s_i \in <0.508; 0.712>$ ; G<sub>2</sub> consisted of the economies for which  $s_i \in <0.304; 0.508>$  and G<sub>1</sub> gathered the economies for which  $s_i < 0.304$  (i.e. the least developed ones). Table 4 presents classification of the studied Latin American economies. Chile constituted a one-element G<sub>4</sub> class. Mexico, Argentina, Colombia and Ecuador formed a four-element G<sub>3</sub> class. G<sub>2</sub> class consisted of three economies, namely: Brazil, Peru and Guatemala. Bolivia and Venezuela created G<sub>1</sub> class.

*Table 4: Division of selected Latin American countries into clusters according to synthetic measure of development (Own calculations)*

Position	Economy	Class
1	Chile	G4
2	Mexico	G3
3	Argentina	G3
4	Colombia	G3
5	Ecuador	G3
6	Brazil	G2
7	Peru	G2
8	Guatemala	G2
9	Bolivia	G1
10	Venezuela	G1

The process of economic development of a national economy should result in a higher standard of living for its citizens. Usually, however, family income is not distributed equally. Gini index is used to measure the extent to which the distribution of income among individuals or households within an economy deviates from a perfectly equal distribution. Gini index ranges from 0 to 100. A Gini index of 0 represents perfect equality, while an index of 100 implies perfect inequality. Due to the fact that it was impossible to gather information on the Gini index for the studied year (i.e. 2017), income inequalities were not included in the taxonomic research. On the other hand, however, Author of the paper considers the income inequalities as an issue of huge significance. Therefore, information regarding the Gini index for selected Latin American countries (latest available data) was presented in table 5. Unfortunately, the problem of income inequalities remains a challenge for each and every studied Latin American economy. The Gini index ranged from 42.7 in Argentina to 51.3 in Brazil. Moreover, it seems, that it may be even higher in Venezuela due to the deterioration of its overall macroeconomic situation (according to the World Bank data the Gini index for Venezuela amounted to 46.9, but the information was available for the year 2006 only).

*Table 5: The Gini index for selected Latin American countries – various years (IndexMundi 2018: World Bank estimate)*

Economy	Gini Index	Year
Argentina	42.7	2014
Bolivia	45.8	2015
Brazil	51.3	2015
Chile	47.7	2015
Colombia	51.1	2015
Ecuador	46.5	2015
Guatemala	48.7	2014
Mexico	48.2	2014
Peru	44.3	2015
Venezuela	46.9	2006

The achieved results were compared with competitive positions of the analysed countries in the Global Competitiveness Reports published by World Economic Forum and expressed by Global Competitiveness Index (GCI) (see table 6). Chile was the most competitive economy among the selected Latin American countries: it was positioned on the 33<sup>rd</sup> place in 2017/2018 ranking and it took the 30<sup>th</sup> position in 2009/2010 ranking. The 2<sup>nd</sup> most competitive economy of them all was Mexico (the 51<sup>st</sup> position in 2017/2018 ranking and the 60<sup>th</sup> place in 2009/2010 ranking). In 2017/2018 ranking Venezuela was the least competitive economy among the

studied Latin American countries: it took the 127<sup>th</sup> place. All studied Latin American economies (but Chile) represent low or very low competitiveness against the background of over 130 national economies analysed by World Economic Forum experts.

*Table 6: Global Competitiveness Index of selected Latin American countries  
 (WEF, 2017, p. ix; WEX, 2016, p. xiii; WEF, 2009, p. 13)*

Economy		2009/10	2017/18	2017/2018- 2009/10 change	Economy		2009/10	2017/18	2017/2018- 2009/10 change
Argentina	Rank	85	92	-7↓	Ecuador	Rank	105	97	+8↑
	Score	3.9	3.9	0.0		Score	3.6	3.9	+0.3
Bolivia	Rank	120	121*	-1↓	Guatemala	Rank	80	84	-4↑
	Score	3.4	3.5*	+0.1		Score	4.0	4.1	+0.1
Brazil	Rank	56	80	-24↓	Mexico	Rank	60	51	+9↑
	Score	4.2	4.1	-0.1		Score	4.2	4.4	+0.2
Chile	Rank	30	33	-3↓	Peru	Rank	78	72	+6↑
	Score	4.7	4.7	0.0		Score	4.0	4.2	+0.2
Colombia	Rank	69	66	+3↑	Venezuela	Rank	113	127	-14↓
	Score	4.0	4.3	+0.3		Score	3.5	3.7	+0.2

\*- Bolivia was excluded from GCI 2017/2018 due to insufficient data, that's why GCI for Bolivia for 2016/17 is presented

#### 4. DISCUSSION

There have been numerous theoretical and empirical studies concentrating on economic development – its factors and barriers, elements and layers (Todaro, Smith 2015; Huggins, Thompson 2017; Perkins 2016; Horúcková, Lebieczik 2014). Giugale (2017) focused on the influence of democratisation and globalisation on economic development. Želazny and Pietrucha (2017) studied the significance of innovation and institutions. The impact of systemic factors on growth and development as exemplified by countries from different regions (including Asia, Latin America, Africa) was examined by Swadźba (2017; 2016; 2015). Müller analysed historical determinants and roots of economic development of selected economies (Müller 2017). The connections between active participation in processes of regional economic integration and economic development were studied and described by Pawlas (2014A). Nafziger (2012) analysed the reasons for rapid recent development in India, Poland, Brazil, China, and other Pacific Rim countries. Economic development of selected African countries was examined by Heshmati (2017). Cornia (2011) studied the connections between regional economic integration processes, economic growth and the problem of inequalities. Wamboye and Tiruneh (2017) focused on the significance of foreign capital for economic development of African countries. The 21<sup>st</sup> century brought rising interest in the concept of sustainable development, which was intensely promoted by the United Nations (Browne 2017; Donohoe 2017). Internet and its openness as an engine of economic growth and innovation was analysed by OECD experts (OECD 2016). Taxonomic methods were used for the evaluation of socio-economic development by Bąba (2016), Grabiński (2003), Młodak (2006), Pawlas (2014B; 2016; 2017; 2018), as well as the team formed by Hrubcova, Loster and Oberguber (2016). Still, however, there is a gap in recent literature regarding the identification and evaluation of disparities in development among Latin American countries with the implementation of taxonomic methods (multidimensional comparative analysis). Therefore, the undertaken research has filled in the existing gap.

#### 5. CONCLUSION

The research project focused on development of ten selected Latin American economies. The comparative study proved the persistence of considerable development disparities among the countries of Latin America. In 2017 the highest level of synthetic measure of socio-economic

development was noted in Chile (Chile constituted a one-element cluster G<sub>4</sub>). Among the leading economies in terms of synthetic measure of development one could also find Mexico and Argentina. The lowest position was taken by Venezuela; Bolivia was another economy with a relatively low level of development measured by synthetic TMD index (Bolivia and Venezuela formed a two-element cluster G<sub>1</sub>). Moreover, the analysis of the Gini index for the selected countries of Latin America did prove that the problem of income inequalities remains a challenge for each and every studied economy. What's more, the achieved results of the study with the application of selected taxonomic methods did fall in line with competitive positions of the analysed Latin American countries presented by World Economic Forum in the Global Competitiveness Report 2017/2018. Chile was classified as the 33<sup>rd</sup> most competitive country in the world (the highest one of all ten studied countries). Mexico was the next Latin American country characterised by a relatively high competitiveness (as compared to other studied economies); it took the 51<sup>st</sup> position in 2017/2018 ranking. Venezuela and Bolivia, i.e. those Latin America economies which were considered the least developed ones according to TMD, were also classified as the least competitive economies among the analysed Latin American countries (they took the 127<sup>th</sup> place and the 121<sup>st</sup> positions respectively). Author would like to point out to several limitations of the study: the number of analysed objects, the set of diagnostic variables, as well as the period of research. Future research should embrace more countries of Latin America and a longer period of time. Author would also like to underline the possibility of analysing a number of fields, e.g. demographic potential, economic potential, labour market, technical and technological infrastructure. Moreover, some limitations were connected with the lack of statistical data for all analysed Latin American countries or the analysed year (e.g. initially Author planned to use two additional diagnostic variables, namely: gross expenditure on research and development as % GDP and number of patents granted by US Patent Office per 1000 population; unfortunately, the statistical data was unavailable for 2017 for all studied ten Latin American economies). In addition to that, Author intends to undertake a much more complex comparative study embracing not only economies of Latin America, but also the United States, Canada, selected European countries, chosen Asian economies and selected African countries.

#### **LITERATURE:**

1. Bąba, W. (2016). Changes in Level of Socio-Economic Development of EU Member Countries in the 2004-2013 Period – Taxonomic Analysis. In: *Proceedings of the 3<sup>rd</sup> International Conference on European Integration VSB - Technical University of Ostrava*.
2. Browne, S. (2017). *Sustainable development: goals and UN goal-setting*. London; New York: Routledge, Taylor & Francis Group.
3. CIA (2018). *The World Factbook*. Retrieved 10.09.2018 from <https://www.cia.gov/library/publications/the-world-factbook/fields/2018.html>.
4. Cornia, G.A. (2011). Economic Integration, Inequality and Growth: Latin America vs. the European economies in transition. In: *UN Department of Economic and Social Affairs (DESA) Working Papers*, No. 101. (p. 1-36). New York: United Nations.
5. Donohue, W.J. (2017). The multinational and the legitimation of sustainable development, *Transnational Corporations*, Vol. 24, no. 3, (p. 49-60). New York : United Nations.
6. Giugale, M. (2017). *Economic development: what everyone needs to know*. New York: Oxford University Press.
7. Grabiński, T. (2003). *Analiza taksonomiczna krajów Europy w ujęciu regionalnym*. Kraków: Wydawnictwo Akademii Ekonomicznej w Krakowie.
8. Hellwig, Z. (1990). Hellwig Z. (1990), *Taksonomia - teoria i jej zastosowania*. Kraków: Wydawnictwo Akademii Ekonomicznej w Krakowie.

9. Hellwig, Z. (1968). Zastosowanie metody taksonomicznej do typologicznego podziału krajów ze względu na poziom rozwoju oraz zasoby i strukturę wykwalifikowanych kadr. *Przegląd Statystyczny*, No. 4. (p. 307-327).
10. Heshmati, A. (2017). *Studies on economic development and growth in selected African countries*. Singapore: Springer Nature.
11. Horúcková, M., Lebedzik, M. (2014). Economic Development of Montenegro and Its Progress Towards EU Membership. In: *Proceedings of the 2<sup>nd</sup> International Conference on European Integration 2014. ICEI 2014. May 15-16, 2014. Ostrava, Czech Republic*, (p. 262-271). Ostrava: VSB - Technical University of Ostrava.
12. Hrubcova, G., Loster, T., Obergruber, P. (2016). The Taxonomy of the Least Developed Countries Based on the Tourism Economic Impact Analysis. In: *Procedia Economics and Finance*. No. 39. *3rd GLOBAL CONFERENCE on BUSINESS, ECONOMICS, MANAGEMENT and TOURISM, 26-28 November 2015, Rome, Italy*. (p. 446-450). Amsterdam: Elsevier. Retrieved 1.10.2018 from [https://ac.els-cdn.com/S2212567116303471/1-s2.0-S2212567116303471-main.pdf?\\_tid=1c7e3c81-b0dc-4574-aae5-4056dc102e38&acdnat=1539696292\\_3d997306b91afb56c7dbe1f4b59d8a37](https://ac.els-cdn.com/S2212567116303471/1-s2.0-S2212567116303471-main.pdf?_tid=1c7e3c81-b0dc-4574-aae5-4056dc102e38&acdnat=1539696292_3d997306b91afb56c7dbe1f4b59d8a37).
13. Huggins, R., Thompson, P. (2017). *Handbook of regions and competitiveness: contemporary theories and perspectives on economic development*. Northampton: Edward Elgar Publishing.
14. INDEXMUNDI (2018). *GINI index (World Bank estimate) - Country Ranking*. Retrieved 10.10.2018 from <https://www.indexmundi.com/facts/indicators/SI.POV.GINI/rankings>.
15. Müller, J. (2017). *State formation, regime change, and economic development*. London; New York: Routledge.
16. Młodak, A. (2006). *Analiza taksonomiczna w statystyce regionalnej*. Warszawa: Difin.
17. Nowak, E. (1990). *Metody taksonomiczne w klasyfikacji obiektów społeczno-gospodarczych*. Warszawa: PWE.
18. Nafzinger, E.W. (2012). *Economic Development* (5<sup>th</sup> edition). Cambridge: Cambridge University Press.
19. OECD (2016). Economic and Social Benefits of Internet Openness. 2015 Ministerial Meeting on the Digital Economy Background Report. *OECD Digital Economy Papers* No. 257. Paris: OECD.
20. Pawlas, I. (2018). Disparities in development based on taxonomic research. A case of Poland in the European Union. In: *Proceedings of the 4<sup>th</sup> International Conference on European Integration 2018. ICEI 2018. May 17-18, 2018. Ostrava, Czech Republic*, (p. 1162-1171). Ostrava: VSB - Technical University of Ostrava.
21. Pawlas, I. (2017). Regional Disparities in Development Based on Taxonomic Research: A Case of Poland. In: *Regional Formation and Development Studies*, Vol. 23, No. 3, (p. 86-101). Klaipėda: Klaipėdos universiteto leidykla.
22. Pawlas, I. (2016). Economic Picture of the Enlarged European Union in the Light of Taxonomic Research. In: *Proceedings of MAC-EMM 2016, 5<sup>th</sup>-6<sup>th</sup> August 2016 in Prague*. Vopava, J., Douda, V., Kratochvil, R., Konecki, M. (eds). (p. 75-82). Prague: MAC Prague consulting Ltd.
23. Pawlas, I. (2014A). Cohesion Fund as an Instrument Stimulating Transport Infrastructure development in Poland. In: *Proceedings of the 16<sup>th</sup> International Scientific Conference FINANCE AND RISK 2014. Bratislava, Slovakia*, Vol. 1. (p. 173-181). Bratislava: Publishing House EKONÓM.
24. Pawlas, I. (2014B). *Rozwój polskiej gospodarki na tle pozostałych krajów Unii Europejskiej w okresie niestabilności w gospodarce światowej*. Katowice: Wydawnictwo Uniwersytetu Ekonomicznego w Katowicach.



25. Perkins, G. (2016). *Socioeconomic status: influences, disparities and current issues*. Hauppauge; New York: Nova Science Publishers, Inc.
26. Pluta, (1977). *Wielowymiarowa analiza porównawcza w badaniach ekonomicznych*. Warszawa: PWN.
27. Swadźba, S. (ed.). (2017). *Systemowe uwarunkowania wzrostu i rozwoju gospodarczego krajów Afryki Subsaharyjskiej*. (176 p.) Katowice: Wydawnictwo Uniwersytetu Ekonomicznego.
28. Swadźba, S. (ed.). (2016). *Systemowe uwarunkowania wzrostu i rozwoju gospodarczego krajów Ameryki Łacińskiej*. (174 p.) Katowice: Wydawnictwo Uniwersytetu Ekonomicznego.
29. Swadźba, S. (ed.).(2015). *Systemowe uwarunkowania wzrostu i rozwoju gospodarczego krajów Azji Południowo-Wschodniej*. (168 p.) Katowice: Wydawnictwo Uniwersytetu Ekonomicznego.
30. Todaro, M.P., Smith, S.C. (2015). *Economic Development* (12<sup>th</sup> edition). Boston: Pearson.
31. Wamboye, E., Tiruneh, E.A. (2017). *Foreign Capital Flows and Economic Development in Africa: the Impact of BRICS versus OECD*. New York: Palgrave Macmillan.
32. WEF (2017). *The Global Competitiveness Report 2017–2018*. (p. ix). Geneva: World Economic Forum.
33. WEF (2016). *The Global Competitiveness Report 2016–2017*. (p. xiii). Geneva: World Economic Forum.
34. WEF (2009). *The Global Competitiveness Report 2009–2010*. (p. 13). Geneva: World Economic Forum.
35. Żelazny, R., Pietrucha, J. (2017). Measuring innovation and institution: the creative economy index. Equilibrium. In: *Quarterly Journal of Economics and Economic Policy*, Vol. 12, Issue 1, (p. 43-62). Toruń: Uniwersytet Mikołaja Kopernika w Toruniu. Instytut Badań Gospodarczych.

## SETTING BID PRICES IN CONSTRUCTION: CASE STUDY OF FORMWORKS

**Petr Aigel**

*Brno University of Technology, Faculty of Civil Engineering,  
Veveří 95, 602 00 Brno, Czech Republic  
aigel.p@fce.vutbr.cz*

**Miloslav Vyskala**

*Brno University of Technology, Faculty of Civil Engineering,  
Veveří 95, 602 00 Brno, Czech Republic  
vyskala.m@fce.vutbr.cz*

**Patrik Janas**

*Brno University of Technology, Faculty of Civil Engineering,  
Veveří 95, 602 00 Brno, Czech Republic  
janaspatrik33@outlook.cz*

### ABSTRACT

*This article deals with the issue of turnover material and its individual types, in particular the formwork. The authors characterise the individual types of formwork from multiple perspectives: traditional formwork and formwork systems; ceiling formwork, wall formwork and column formwork. The paper's analytical part deals with the issue of assembly and disassembly of formwork and tangentially addresses the issue of formwork rental. Based on the interviews conducted, the factors influencing the price of formwork rental are discussed. The authors also analyse the prices of assembly and disassembly of formwork established based on market research and the related influencing factors. The analysis is conducted on a sample of real data relating to construction projects and draws on interviews with experts in the field. A detailed sample analysis is conducted using foundation structures; aggregate results are further presented in respect of vertical and horizontal structures and staircases. The analysis shows that the price of assembly and disassembly of formwork is most significantly affected by the complexity of the construction element, i.e. its shape and appearance.*

**Keywords:** *formwork, calculation, turnover material*

### 1. INTRODUCTION

The term "turnover material" denotes material that is not consumed in the process of construction of a building project. This includes material that serves as an auxiliary structure in implementation of certain technological stages of a project. Turnover material includes e.g. formwork, scaffolding, sheeting/earthwork support, and Jersey barriers. This article will deal with formwork and the issues related to setting its bid price for customers. The price consists of the daily rental amount paid by the contractor to the company that leases out the formwork; other parts of the price consist of costs of formwork assembly and disassembly, which are analysed in more detail below.

### 2. FORMWORK TYPES

Formwork is a temporary or permanent auxiliary structure that forms a mould for casting concrete in order to create (reinforced) concrete structures and elements or to deposit and compact earth in construction of earthen structures. The mould consists of formwork sheeting (shell) and internal and external braces. Formwork position is secured by a retaining and supporting system.

The formwork sheeting is the part which is in direct contact with the wet concrete. The properties of the shell determine the resulting quality of concrete surfaces. The shell is often treated in various ways, especially when dealing with face concrete. As the poured wet concrete exerts significant pressures on the shell, the formwork requires external bracing consisting of a grid of perpendicular bearers. The bearers serve to attach elements comprising the shell and to transfer the forces exerted on the shell by the concrete. These forces need to be carried to other solid construction parts. In horizontal structures, this is accomplished by a supporting system which carries the vertical loads to lower completed structures or the ground. In vertical structures, a retaining reinforcement is used to maintain optimal stiffness using struts and supporting triangular frames. These braces are then anchored to the final structure in order to prevent the formwork from being lifted by the freshly poured concrete. Reusable formwork is most often used for casting reinforced concrete monolithic structures. Such formwork is considered in terms of formwork lifetime, which is the time period during which the formwork can serve its function without developing defects. The actual lifetime depends on the way the formwork is treated during transport, assembly and disassembly. Theoretical lifetime is based on the assumption of proper use and forms the basis for determining the depreciation rate. The depreciation rate expresses the annual percentage of wear and tear of the formwork. The depreciation captures the gradual decrease in the value of the property of the company owning the formwork. The decrease is included in the company's costs by means of first establishing the percentage of the annual depreciation incurred per calendar day. This percentage rate is the base for calculating the daily amount of formwork rental. The types of reusable formwork include the traditional timber formwork, specialised formwork and formwork systems [1]. Traditional timber formwork uses soft construction lumber. The shell utilises planed and non-planed boards in the I. and III. quality classes. The number of times they can be reused has a significant impact on the costs of the formwork. Reusing the material can be very labour intensive, especially the removal of the forms and cleaning. Currently, timber formwork in larger construction projects is only used as a necessary complement of the formwork mould, which consists of suitable metal or plastic formwork systems. Specialised formwork includes e.g. tunnel formwork, self-climbing formwork, travelling formwork and sliding formwork. The design of the concrete structure must be drawn up simultaneously with the design of these special types of formwork. As these types of specialised formwork are relatively expensive, a larger number of reuse cycles is necessary to amortise the costs associated with acquisition [1]. Formwork systems comprise a set ("system") of factory-produced elements. These forms can withstand greater pressures, have higher accuracy and joining the individual elements together is not very labour intensive. Some important suppliers of these systems include DOKA, PERI, ULMA, NOE, and MEVA. The main advantage of these systems consists in rapid assembly and high turnover of the material which significantly affects the costs of implementation. The expected turnover of formwork systems ranges from 30 to 300 cycles. Each manufacturer utilises somewhat different elements of the system and materials, most often steel and plywood. The materials used in formwork systems should ensure multiple reuse. The construction of concrete structures is a "wet" process where the formwork is exposed to aggressive cement conditions in concrete mixtures as well as environmental effects [1, 2]. Ceiling (slab) formwork comprises four elements and is used in all kinds of ceiling structures, smooth ceiling slabs, vaulting ribs, joists and girders. The four-part ceiling formwork is the most common because its assembly does not require heavy machinery and is suitable for closed and complex floor plans. The system comprises timber beams of various lengths, multi-layered sheeting using 21 mm thick panels, steel ceiling props up to 5 m tall, fork heads and holding tripods. The number of beams and props and their spacing is determined by the manufacturer and depends on the thickness of the slab [3, p. 139].

Wall formwork is a panel formwork emphasising ease of assembly and shorter formwork deployment times. The individual elements of various types are joined with a type coupler. The elements can be used in horizontal as well as vertical arrangement. System elements for connecting walls, branching walls and corners are also available. Stabilisation elements provide the necessary stability of the formwork. The maximum allowed wet concrete pressure is up to 80 kN/m<sup>2</sup>. Brackets and platforms are available to ensure safety at work. Powder coating of the individual panels makes cleaning easier [4]. Column formwork supplements wall formwork; 90 cm panels can also be used in wall formwork. There is a possibility to create sharp or bevelled edges using triangular mouldings. The maximum permissible pressure of wet concrete is 100 kN/m<sup>2</sup>. Special nuts enable joining the formwork panels using one hand. Adjustable concreting platforms and ladders ensure safe access [4].

### **3. FORMWORK RENTAL PRICE**

The bid price for which companies rent formwork is mainly affected by the complexity of the construction element (shape, required face appearance) and bearing capacity (height and thickness). In vertical structures, the height and width of the structure will be reflected in the costs by means of increased number of joining and hardening elements. In horizontal structures, the price is most affected by the thickness of the slab. Increased thickness of the ceiling slab requires a greater density of secondary beams and supporting elements (stacking towers, slab props). The price can also be significantly affected by the competence of the manager who ensures the formwork rental for the company. Since each project is unique, the specific possibilities need to be dealt with on an ad hoc basis. This concerns the quality of the concrete, appearance of the concrete face, presence of cranes or formwork sheeting to deliver the desired surface structure to the customer. Individual projects differ not only in terms of the materials and types of formwork systems used, but also in terms of their turnover. In a large part of current projects, it is necessary to ensure high turnover of the formwork in order to ensure that its quantity on the construction site stays as low as possible. For instance, in construction of more complex walls, the formwork is used in several separate stages in order for one set to be reused multiple times. This puts a significant emphasis on the professional expertise of the company's technical department responsible for formwork rental. In the above case, formwork rental is determined based on sets and costed in EUR/m<sup>2</sup>/day. The process of calculating the prices using the above unit of measurement is described in the following paragraph. Each company providing formwork rental services has its own technical department responsible for creating blueprints of the formwork composition. Specialised software is employed for each specific type of formwork. For instance, ULMA's system is called Grafssystem, PERI uses PERI CAD and DOKA utilises Tipos8. The software tools work in a similar way. Each of the aforementioned companies has its own price database including individual formwork elements and parts. Such databases contain thousands of items comprising the proprietary formwork systems. All individual elements are assigned a price. The calculation itself is carried out using computing programs such as Microsoft Excel. The program enables to download individual items from the database based on the formwork composition blueprint prepared by the technical department. The company renting the formwork sets a daily rental as a percentage of the price of the individual formwork elements. The actual percentage differs and directly depends on the wear-out rate of the turnover material. Table 1 contains preliminary percentage of formwork wear per contract [5, 6, 7, 8, 9].

*Table following on the next page*

Formwork element	Material	Value Wear [%]	Number of reuse cycles
Ceiling props	steel	2-3	up to 50
Wall formwork	steel, wood	3-7	up to 34
Column formwork	steel, wood	3-5	up to 34
Stacking towers	steel	2-4	up to 50
Plywood	wood	9-14	up to 11
Timber bearers	wood	7-11	up to 14
Folding platforms	steel, wood	3-5	up to 34

*Table 1: Wear percentage of the individual formwork elements [10].*

The table shows that timber elements wear out the fastest. The wear of metal elements is negligible, and the percentage rate is thus correspondingly lower. The price of daily rental usually also includes the costs of design activities. Ancillary costs of design activities are only included in cases of complex and technically demanding construction projects. The price does not include the costs of transport. Generally speaking, the market price of road transport of a 200 m ceiling or 200 m wall formwork is approximately 1.35 EUR/km. In cases of damage or loss of the rented formwork, the customer company is obliged to compensate the amount of damage according to internal regulations of the rental company [5, 6, 7, 8, 9]. From the perspective of the investor, the price of using the formwork becomes a part of life cycle costs [11]. In order to determine the average market price for a daily rental, four companies which regularly rent formwork were contacted. From the resources thus obtained, the authors calculated the daily rental per square metre on order. The daily rental is around 0.56 EUR/m<sup>2</sup>/day.

#### **4. ANALYSIS OF THE PRICE OF FORMWORK ASSEMBLY AND DISASSEMBLY**

Calculating the costs of formwork assembly and disassembly puts significant demands on the professional expertise and experience of the budgeters. The price of formwork assembly and disassembly is specified in EUR/m<sup>2</sup>. The price is influenced e.g. by requirements on accuracy, whether structural or face concrete is involved, the current market conditions, an emphasis on speed of construction, and the selection of the formwork system. In terms of construction, the price is most affected by the geometric shape of the structure, its dimensions (height, width, thickness), the number of cutouts and openings, linings, grooves, sparings and the number of hardening and supporting elements [5, 6, 7, 8, 9]. Table 2 includes a calculation of the average bid price of formwork assembly and disassembly per square metre of foundation structures. The prices are not inclusive of the daily formwork rental.

*Table following on the next page*

<b>Foundation structures</b>						
Type of foundation structure	Foundation plate formwork [EUR/m <sup>2</sup> ]	Plate formwork removal [EUR/m <sup>2</sup> ]	Foundation strip formwork [EUR/m <sup>2</sup> ]	Strip formwork removal [EUR/m <sup>2</sup> ]	Foundation slab formwork [EUR/m <sup>2</sup> ]	Slab formwork removal [EUR/m <sup>2</sup> ]
CORTEX administrative building	7.74	1.93	7.74	1.93	-	-
Slovanská Grammar School in	5.8	1.55	5.8	1.55	-	-
Uherské Hradiště Hospital	5.42	1.16	5.42	1.16	5.42	1.16
Residential building in Komín	5.8	1.16	-	-	-	-
MMCI – Radiotherapy unit	4.64	1.55	5.61	2.71	-	-
BALUO – Testing pool	5.8	1.55	-	-	-	-
BALUO – Testing hall	5.8	1.55	5.8	1.55	5.8	1.55
Single family home in Jundrov	5.42	1.55	6.96	6.38	-	-
Residential building at Veslařská	5.8	1.55	5.8	1.55	5.8	1.55
Polyfunctional building in Brno	9.67	3.87	-	-	9.67	3.87
Residential building in Prosek	5.8	1.55	5.8	1.55	-	-
Třebíč Hospital	5.42	2.32	5.42	2.32	5.42	2.32
URS indicative price	8.4	2.09	8.4	2.09	8.4	2.09
URS indicative price without daily rental	4.06	2.09	4.06	2.09	4.06	2.09
Interval	4.64-9.67	1.16-	5.42-7.74	1.16-6.38	5.42-9.67	1.16-
Arithmetic average	6.11	1.78	6.04	2.28	6.42	2.09

Table 2: Price of foundation structures formwork (prepared by the author based on [10, 12])

Table 2 shows that the supplier companies charge on average 6.11 EUR/m<sup>2</sup> for the assembly of foundation plate formwork and 1.78 EUR/m<sup>2</sup> for the disassembly of the same. Foundation strip formwork assembly costs on average 6.04 EUR/m<sup>2</sup> while removal costs 2.28 EUR/m<sup>2</sup>. Assembly and disassembly of foundation slabs formwork is carried out for the average price of 6.42 EUR/m<sup>2</sup> and 2.09 EUR/m<sup>2</sup>, respectively. The table further shows that the price per square metre of formwork ranges from 4.64 EUR/m<sup>2</sup> to 9.67 EUR/m<sup>2</sup> and that the most common price per square metre equals 5.8 EUR. Higher prices are mostly the result of a greater complexity of the concrete elements. This means that the more complex the structure, the higher the price of formwork assembly and disassembly, and vice versa – in simpler structures, the price is about 0.39 to 0.77 EUR/m<sup>2</sup> lower than the average. An interesting observation following from the analysis of the data contained in Table 2 is that the indicative price is significantly below the usual market price; this is true even in exceptional cases where the indicative price covers the daily formwork rental. Similar approach was used for other concrete structures.

#### 1. Vertical structures

- column formwork assembly costs on average 6.15 EUR/m<sup>2</sup> while its removal costs 1.47 EUR/m<sup>2</sup>;
- the average price of wall formwork assembly and disassembly is 6.07 EUR/m<sup>2</sup> and 2.09 EUR/m<sup>2</sup>, respectively. Attic formwork assembly costs on average 5.8 EUR/m<sup>2</sup> while its removal costs 1.55 EUR/m<sup>2</sup>.

## 2. Horizontal structures

- the average price of ceiling structure formwork assembly is 6.04 EUR/m<sup>2</sup>, the price of disassembly averages 1.74 EUR/m<sup>2</sup>;
- Girder formwork assembly costs on average 5.92 EUR/m<sup>2</sup> while its removal costs 1.43 EUR/m<sup>2</sup>.

## 3. Staircases

- assembly of staircase landing and half-landing formwork costs on average 11.49 EUR/m<sup>2</sup> while its removal costs 3.4 EUR/m<sup>2</sup>;
- assembly of straight steps formwork costs on average 33.62 EUR/m<sup>2</sup> while its removal costs 6.96 EUR/m<sup>2</sup>;
- the price of staircase formwork assembly is influenced by a number of other factors which must be taken into account in budgeting the costs of works. For example, a greater height significantly increases the labour intensiveness; attaching the staircase to the side wall also affects the cost.

For graphical depiction of the above, see Figure 1.

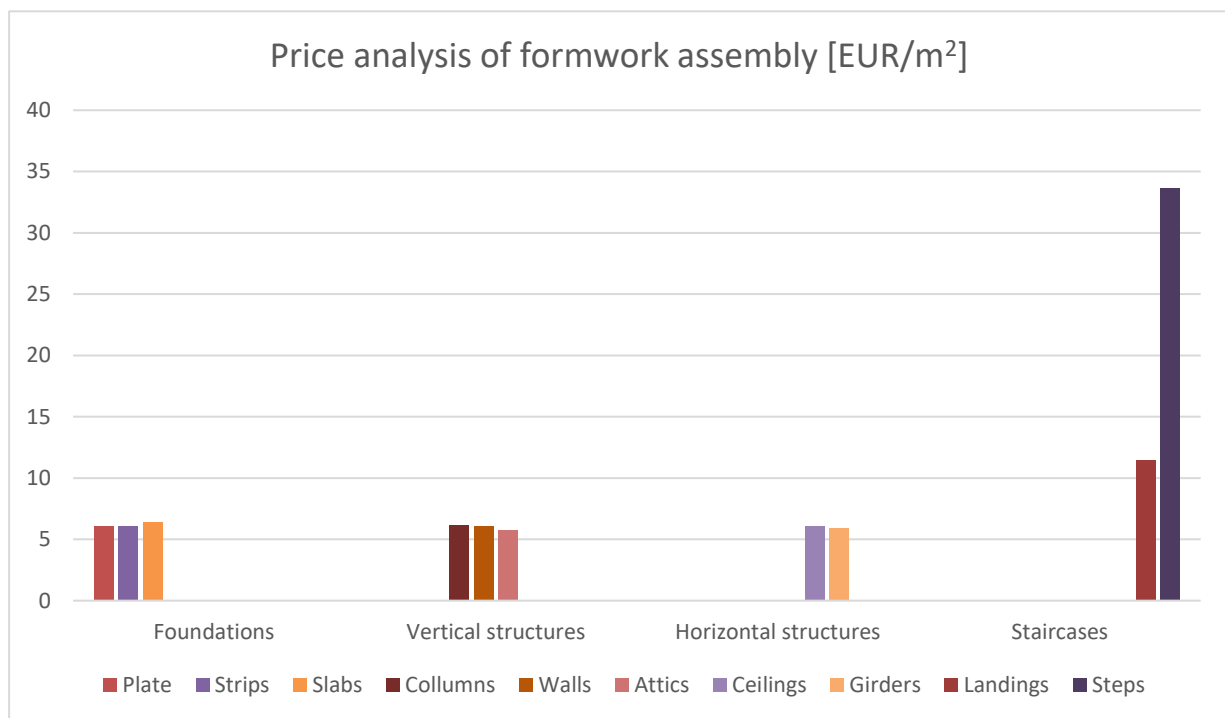

Figure 1: Price analysis of formwork assembly (prepared by the authors)

## 5. CONCLUSION

The investors exert pressure indirectly not only in respect of the manufacturers of formwork systems, but also on the companies that carry out the assembly itself. This results in continuously increasing turnover of the material, greater compatibility of the individual elements, and decreasing time of construction of monolithic structures. This puts considerable demands on the organisational abilities of the technical supervisors as well as the skills of the workers and craftsmen. As the above demonstrates, concrete structures such as the foundations, and vertical and horizontal structures are not especially demanding and the prices per square metre are similar. Conversely, the price in far more complex staircases is significantly higher. It is thus possible to generally conclude that the price is most significantly affected by the complexity of the individual construction element, i.e. its shape and appearance.

**ACKNOWLEDGEMENT:** *The project presented in this article is supported by research grant FAST-S-18-5154 entitled "Company costs and tender prices management in the construction sector".*

**LITERATURE:**

1. Ladra, Josef. (2002). *Technologie staveb 11: realizace železobetonové monolitické konstrukce budov (Construction technology 11: Creating reinforced concrete monolithic structures)*. ISBN 80-01-02487-3. Praha: Vydavatelství ČVUT,
2. Král, Pavel a Hrázský Jaroslav. (2004). *Použití velkoplošných materiálů na betonářská bednění (Using large-area materials in concrete formwork)*. ISBN 80-7157-769-3. Brno: Mendel University in Brno, Faculty of Forestry and Wood Technology. Folia Universitatis Agriculturae et Silviculturae Mendelianae Brunensis. Facultas Silviculturae et Technologiae Ligni.
3. Chromík, Róbert a Klein Štefan. (2003). *Strojní zařízení pro stavby: stavební mechanizace: pomocné konstrukce: eurokatalog stavebních výrobků (Construction machinery: construction mechanisation: auxiliary structures: European catalogue of construction products)*. ISBN 80-239-0172-9. Brno: Art-Projekt. Construction tables.
4. Stěnové bednění (*Wall formwork*). PERI Česká republika – Formwork Scaffolding Services [online]. Copyright © 2017 [retrieved on 09 January 2017]. Available at: <https://www.peri.cz/produkty/bedn%C4%9Bn%C3%AD/st%C4%9Bnov%C3%A9-bedn%C4%9Bn%C3%AD.html>
5. Interview with Ing. Martin SCHWAB, ULMA branch manager. Brno, 24 February 2017.
6. Interview with Ing. Jakub CINCIBUS, ULMA formwork technician. Brno, 24 February 2017.
7. Interview with Ing. Tomáš DONÁT, Head of the division of monolithic structures at SKANSKA. Brno, 20 March 2017.
8. Interview with Ing. Martin MOUDŘÍK, Head of the division of monolithic structures at PSG. Brno, 10 February 2017.
9. Interview with Bc. Marek HUDEČEK, Technical supervisor at PSG. Brno, 10 February 2017.
10. Patrik Janás *Analýza nákladů obrátkového materiálu stavebního objektu (Analysis of the costs of turnover material in a construction project)*. Brno, 2017. BA Thesis. Brno University of Technology, Faculty of Civil Engineering, Institute of Economics and Management. Supervisor Ing. Petr Aigel, Ph.D.
11. Bišek, V.; Hanák, T. Conceptual framework for management of the life cycle costs of buildings. In 26th International Scientific Conference on Economic and Social Development – "Building Resilient Society". Book Series: International Scientific Conference on Economic and Social Development. Varazdin, Croatia, pp. 466-472, ISSN: 1849-7535, 2017.
12. Cenová soustava ÚRS (*ÚRS Price System*), available at: <https://www.pro-rozpocty.cz/software-a-data/cenova-soustava-urs-cs-urs-/> (*in Czech*)



## COMPARING CUSTOMER MANAGEMENT OF THE NEW CUSTOMER GENERATION USING DESKTOP VERSUS SMARTPHONE IN E-COMMERCE CONDITIONS

**Radovan Bacik**

*Faculty of management, University of Prešov, Slovakia  
radovan.bacik@unipo.sk*

**Jakub Horvath**

*Faculty of management, University of Prešov, Slovakia  
jakub.horvath@smail.unipo.sk*

**Richard Fedorko**

*Faculty of management, University of Prešov, Slovakia  
richard.fedorko@unipo.sk*

### ABSTRACT

*We live at a time when the technical world is significantly ahead of other factors influencing human life and it is almost impossible to stop this development. A great breakthrough can be seen in the year 1990, when the emergence of the Internet caused immediate access to information. Given the social, cultural or financial differences in the society, access to the Internet has been largely limited or even totally excluded. Countries that have not experienced this scarcity have begun to understand the strength and potential of its use. There is a surplus of products within the global market, so new companies have to differentiate considerably from others in order to break the market for their products. Here it comes to the e-commerce scene, which becomes the main means of dealing with this situation. The objective of this article is to highlight how to manage a new generation of customers when shopping online and what are the preferences when choosing between desktop and smartphone.*

**Keywords:** *Consumer behaviour, E-commerce, New generation of customers, Smartphone*

### 1. INTRODUCTION

E-business in translation means e-commerce. It is usually described as a senior e-commerce group. E-business represents the management of business processes on the Internet (Čorba, Nastišin 2016). These processes include electronic purchasing and selling of products, needs and services, customer service, order processing, payment processes, further cooperation with business partners, sharing information, gaining members and many others (Madleňák 2004; Bačík, Gburová, Štefko 2015). In short, the importance of e-business can be summarized as a comprehensive e-business that uses information and communication technologies to improve business processes and the quality of customer service thanks to the use of the Internet and technology (Mariga 2003; Bačík, Nastišin, Gavurová 2017). E-commerce in translation also means e-commerce, but it is already perceived in the narrower sense of the word (Sedláček 2006). E-commerce significantly influences the dynamics of the business environment as well as the way people and organizations trade with each other. Gangopadhyay (2001) in his book lists several authors of e-commerce definitions:

- As first he mentions Garnter Group (1999), who stated that e-commerce represents a dynamic set of technologies, resources and business processes that linked organizations, consumers and communities.
- We agree with Timmers (1998), who defined e-commerce as any form of business transaction where both parties interact electronically instead of physical exchange of money or direct physical contact.

- A very comprehensible definition of e-commerce is also the statement by Kalakota et al. (1997) who simply explains that e-commerce is buying and selling via digital media. It is also a market for the sale, trading and distribution of goods and services in an electronic environment.

The combination of information and communication technologies has expanded its applications into sales processes as well (Karlíček, Král 2011). One of these applications is e-commerce. E-commerce combines information technologies, telecommunication technologies and business processes to ensure a unique environment when doing business (Monzel 2006; Mura, Zulová, Madleňák 2016). It is a comprehensive system of trading with goods, services and information using computer networks, including a public Internet network (Muneesh 2011; Gburová, Matušíková, Benková 2015).

E-commerce is a collection of modern trading methods and carries these elements (Thanasankit 2003):

- Non-cash payment - e-commerce allows us to make use of credit card, debit card, smart card, direct bill payment and other electronic payment options.
- Availability of 24/7 customer service - e-commerce automates business dealings and the way they provide customer service. It is available anytime, anywhere thanks to the online environment.
- Promotion/marketing - e-commerce enhances the reach of advertising, product promotion, and business services. This helps to improve marketing management.
- Increased sales - Through e-commerce, product orders can be generated anytime, anywhere without any human intervention. It provides a large increase in existing sales.
- Support - e-commerce provides a variety of ways to provide assistance before and during shopping to provide a better customer service.
- Inventory management - e-commerce automates inventory. The results are generated as soon as we request them. Product inventory management becomes very efficient and simple to control.
- Improved communication - e-commerce provides ways for faster, more effective and more reliable communication with customers and business partners.

E-commerce determines the amount of needs within organizations (Gburová, Matušíková 2017). Enables and facilitates the electronic market, allows businesses to reduce service costs, improve delivery speeds, simplify and eliminate inefficient business process elements (Gero 2012). It also supports the delivery of product, service and payment information, as well as the exchange of information with customers (Štarchoň, Lizbetinova, Weberová 2016). It can enhance the identity and image of the business, enable new customer's access and generate new business opportunities (Kaplan 2012).

## **2. METHODOLOGY**

The main objective of this article is to find out the differences in the customer behaviour of the new generation of customers in the relationship between desktop and smartphone in terms of e-commerce. To find out these differences the method of descriptive statistics was used. The research sample is defined as a new generation of customers, i.e. the millennials. The article retains the method by Young (2017), according to which the millennials is referred to as the 'Y generation', which represents the age group 18-34 years. Primary resources for the purpose of this article were obtained by carrying out quantitative research through the CAWI method (Computer Assisted Web Interview). The data collection was carried out in the form of an electronic questionnaire.

The data collection took place in April-May 2018. For the purposes of quantitative research, we surveyed a basic set of students at the Faculty of Management of the University of Prešov. The survey sample consists of 396 respondents.

### 3. RESULTS

*Table 1: Devices used to connect to the Internet (Own elaboration)*

	Frequency	%	Cumulative %
Smartphone	324	81.8	81.8
Desktop / Notebook / Laptop	66	16.7	98.5
Total	396	100.0	

Respondents are most often connected to the Internet via smartphones (N = 324; 81.8%). 16.7% of the respondents (N = 66) connected via desktops/laptops).

*Table 2: Time spent browsing websites daily on the Internet via smartphones (Own elaboration)*

	Frequency	%	Cumulative %
Do not use it	3	0.8	0.8
hour per day	99	25.0	25.8
Within 2 hours	132	33.3	59.1
Within 6 hours	96	24.2	83.3
Within 8 hours	30	7.6	90.9
More than 10 hours	36	9.1	100.0
Total	396	100.0	

99 respondents (25%) spend an hour of daily browsing on the Internet via the smartphone. Within two hours, 132 respondents (33.3%), up to six hours 96 respondents (24.2%), up to eight hours 30 respondents (7.6%) and over ten hours 36 respondents (9.1%). Three respondents do not use their smartphone for this activity (0,8 %).

*Table 3: Time spent browsing websites daily on the Internet via desktops/laptops (Own elaboration)*

	Frequency	%	Cumulative %
Do not use it	81	20.5	20.5
hour per day	126	31.8	52.3
Within 2 hours	111	28.0	80.3
Within 6 hours	51	12.9	93.2
Within 8 hours	27	6.8	100
Total	396	100.0	

126 respondents (31.8%) spend an hour of daily browsing on the Internet via a desktop/laptop. Within two hours, 111 respondents (28%), up to six hours 51 respondents (12.9%), and up to eight hours 27 respondents (6.8%). 80 respondents (20.5%) do not use this activity on these devices. Nobody chose the option spending more than ten hours.

Table 4: Frequency of online shopping (Own elaboration)

	Frequency	%	Cumulative %
Several times a year	69	17.4	17.4
Several times a half a year	126	31.8	49.2
Several times a month	177	44.7	93.9
Several times a week	24	6.1	100.0
Total	396	100.0	

24 respondents (6.1%) shop via the Internet often, or several times a week. Occasionally, or several times a month, 177 respondents purchased (44.7%). Rarely, or several times a year, 126 respondents purchased (31.8%). Very rarely, or several times a year, 69 respondents purchase (17.4%).

	Frequency	%	Cumulative %
2	9	2.3	2.3
3	51	12.9	15.2
4	189	47.7	62.9
5	147	37.1	100.0
Total	396	100.0	

Table 5: Experiencing shopping via the Internet (Own elaboration)

This question was carried out in the form of the Likert scale, where one meant 'very negative' and five 'very positive'. On this scale, respondents most often identified their experience as 4 (N = 189; 47.7%). Then they rated other options such as five (N = 147; 37.1%) and three (N = 51; 12.9%). The lowest number of respondents (N = 9; 2.3%), i.e. those who had negative experiences with internet shopping, marked the option two. A very negative experience did not occur in this case.

Table 6: Descriptive statistics of shopping experience via the Internet (Own elaboration)

Mean	Median	Modus	St. Deviation	Minimum	Maximum	Percentile	
						25	75
4.1969697	4	4	0.7439824	2	5	4	5

The table above shows the outputs of the basic numeric attributes of the survey item that identified the Internet shopping experience. This item was conceived in a five-step scale, with the higher code number <1; 5> defining a more positive experience. The diameter is  $\approx 4.2$ , which is a relatively high value when looking at the five degree scale. The medial, which highlights the fact that at least half of the respondents point to the second most frequented value of four, and therefore has a positive shopping experience. The second half is distributed at values less than four. The most common value is four. The deviation was  $\approx 0.7$ . The minimum and maximum suggests that the full range of responses has not been used. None of the respondents indicated the possibility that they had a very negative experience with online shopping. By focusing on the percentage, 25% of the respondents indicated option three or less, i.e. their experience is neutral or bad.

*Table 7: Trust in Internet shopping (Own elaboration)*

	Frequency	%	Cumulative %
1	6	1.5	1.5
2	21	5.3	6.8
3	105	26.5	33.3
4	168	42.4	75.8
5	96	24.2	100.0
Total	396	100.0	

This question was carried out in the form of the Likert Scale, where one meant "I do not Trust" and five "I do trust". On this scale, respondents chose the option four the most frequently (N = 168; 42.4%). Other options rated by the respondents were the option three (N = 105; 26.5%) and five (N = 96; 24.2%). The lowest number of respondents, with the lack of trust in online shopping chose the option two (21 respondents representing 5.3%) and the option one (6 respondents representing 1.5%).

*Table 8: Descriptive statistics of trust in internet shopping (Own elaboration)*

Mean	Median	Modus	St. Deviation	Minimum	Maximum	Percentile	
						25	75
3.8257576	4	4	0.90983	1	5	3	4

The table above depicts the outputs of the basic numeric characteristics of the query item that surveyed trust in internet shopping. This item was conceived in a five-step scale, with the higher code number <1; 5> defining a higher trust level. The diameter is  $\approx 3.8$ , which is not a high value when looking at the five degree scale. The medial, which highlights the fact that at least half of the respondents chose the second most favoured value four. The second half chose values lower than four. The most common value is four. The deviation  $\approx 1$  declares a higher "match identity". The minimum and the maximum suggests using the full range of responses. By focusing on the percentage, 25% of the respondents indicated option three or less, which means that they do not trust.

#### 4. CONSLUSION

According to Kaplan (2012), the transfer of information or the change takes place in the communication process. Already since remembrance, mankind has attempted to use different means of transmitting information unless it has been possible to exchange them face to face. Nowadays we can state that the commercial use of the Internet and the World Wide Web and its application in the field of electronic business, is the so-called 'e-business'. The huge development and growth of computers, the Internet, mobile phones, and other information and communication technologies have fundamentally influenced the way companies trade with each other and how they sell products to final customers. Businesses that are currently using e-commerce are working to make the best use of the benefits that e-commerce and e-business bring (Havlenka 2001). Based on the above findings, we can say that representatives of the new generation of customers and millennials are most often connected to the internet via their smartphones (81.8%). 33.3% of the respondents is browsing websites and e-shops via smartphones for two hours daily, to six hours deaily 24.2%. The same activity is carried out by one respondent (31.8%) via the desktop and 44.7% of the respondents spent two hours by brownging on the internet daily through a desktop. Milenals mostly buy several times a month (44.7%) or several times per half a year (31.8%). Young consumers have mostly positive experiences with online shopping (84.8%) and 66.6% of young consumers trust in it.

**ACKNOWLEDGEMENT:** *This article is one of the partial outputs under the scientific research grant VEGA 1/0806/16 – “Research on issues of consumer behaviour of a new generation of customers with emphasis on identifying preferences and usability of mobile platforms in the process of e-commerce of the subjects localized predominantly on the Central European Market” and VEGA 1/0789/17 – “Research of e-commerce with relation to dominant marketing practices and important characteristics of consumer behaviour while using mobile device platforms.”*

#### **LITERATURE:**

1. Bačík, R., Gburová, J., Štefko, R. (2015). Impact of the Internet Marketing on the Slovak Consumer. *Central European Conference on Finance and Economics (CEFE)*. Herlany, Slovakia: 30.9. -1.10. 2015, 21-28.
2. Bačík, R., Nastišin, L., Gavurová, B. (2017). The role of social media in the light of building a strong online brand awareness. *5th International Conference Innovation Management, Entrepreneurship and Sustainability (IMES)*. Czech republic, Prague, 25-26.5.2017. pp. 38-47.
3. Čorba, J., Nastišin, L. (2016). Online reputation of companies that have implemented the EMAS III scheme, *International Conference on Engineering Science and Production Management (ESPM)*. Slovakia, 16.-17.4.2015. pp. 45-48.
4. Gangopadhyay, A. (2001). *Managing Business with Electronic Commerce: Issues and Trends*. London: Idea Group Inc.
5. Gburová, J., Matušiková, D., Benková, E. (2015). Perception of tourist destination brand. *Ekonomičnyj časopys - XXI = Economic annals – XXI*, 5-6 (2015), 20-23.
6. Gburová, J., Matušiková, D. (2017). Image of retail and its impact on consumer purchasing decisions. *Education excellence and innovation management through Vision 2020: from regional development sustainability to global economic growth: proceedings of the 29th International Business Information Management Association conference (IBIMA)*: Vienna, Austria: 3.- 4.5. 2017. Norristown: International Business Information Management Association, 3151-3158.
7. Gero, Š. (2012). *Komunikácia – umenie – marketing*. Nitra: FF UKF.
8. Havlenka, J. (2001) *Dělejte byznys na internetu*. Praha: Computer Press.
9. Kaplan, A. M. (2012). If you love something, let it go mobile: Mobile marketing and mobile social media 4x4. In: *Business Horizons*, Vol. 55, No. 2, p. 129-139. ISSN 0007-6813.
10. Karlíček, M., Král, P. (2011). *Marketingová komunikace. Jak komunikovat na našem trhu*. Praha: Grada Publishing.
11. Madleňák, R. (2004). *Elektronický obchod*. Žilina: Žilinská univerzita.
12. Mariga, J. (2003). *Managing E-commerce and Mobile Computing Technologies*. London: Idea Group Inc.
13. Monzel, M. (2006). *99 Tipps für erfolgreiche Werbung*. Berlin: Bibliographisches Institut.
14. Muneesh, K. (2011). *Trust and Technology in B2B E-Commerce: Practises and Strategies for Assurance*. Retrieved. 17-10-2018 from:  
[https://books.google.sk/books?id=W-2eBQAAQBAJ&dq=B2B+e-commerce&hl=sk&source=gbs\\_navlinks\\_s](https://books.google.sk/books?id=W-2eBQAAQBAJ&dq=B2B+e-commerce&hl=sk&source=gbs_navlinks_s).
15. Mura, L., Zulová, J., Madleňák, A. (2016). Strategic management and management of personnel costs: Employing young people in the Slovak Republic. *Problems and Perspectives in Management*, 14(1), pp. 79-84.
16. Sedláček, J. (2006). *E-komerce, internetový a mobil marketing od A do Z*. Praha: BEN – technická literatura.

17. Štarchoň, P., Lizbetinova, L., Weberová, D. (2016). Clustering in Relation to Brand Perception: An Example Based on Czech Consumers. *Vision 2020: innovation management, development sustainability and competitive economic growth: proceedings of the 28th international business information management association conference (IBIMA)*. Seville, Spain: 9-10.11. 2016. Norristown: International business information management association, 2271-+.
18. Thanasankit, T. (2003). *E-commerce and Cultural Values*. London: Idea Group Inc.
19. Young, M., 2017. *Ogilvy o reklamě v digitálním věku*. Bratislava: Svojtka&Co.

## ECONOMIC ASPECT OF COUNTERING THE FINANCING OF TERRORISM

**Aleksandr N. Litvinenko**

*Saint-Petersburg University of the Ministry of Internal Affairs of Russian Federation, Russia  
lanfk@mail.ru*

**Liudmila A. Guzikova**

*Peter the Great Saint-Petersburg Polytechnic University, Russia  
guzikova@mail.ru*

### **ABSTRACT**

*The paper considers the problem of economic counteraction against terrorism from the standpoint of elimination the channels of its financing. The aim of the paper is to identify the ability of the Russian system of national security to increase effectiveness of countering the financing of terrorism. Theoretical explanations of terrorism is studied, methodology of economic counteracting the financing of terrorism stated in legal documents is analyzed, evolution of the Russian system of countering the financing of terrorism is traced, the today practices are discussed, existing problems are identified. Recommendations on interstate co-operation, monitoring of financial operations, operational work and changes in the system of personnel training are formulated.*

**Keywords:** *counteraction against terrorism, financing of terrorism, methodology of countering financing of terrorism, Russian system of counteraction against financing of terrorism*

### **1. INTRODUCTION**

Today, in the system of supranational risks associated with the national security of Russia, along with the credit and financial sphere, permeated with corruption, as well as with the zones of illicit drug traffic, the financing of terrorism is an area of special attention. The achievements in countering the financing of terrorism are largely predetermined by the effectiveness of the state's efforts to undermine the economic foundations of terrorism, because these two activities are interconnected. Within the framework of the authors' logic, it is necessary to compare what the theory offers and what today's Russian practice provides for resolving the contradiction between the non-disappearing terrorist threats and the insufficient effectiveness of the tools to prevent them. The aim of the paper is to identify how the effectiveness of the Russian system of national security in its economic counteraction against terrorism can be increased. The research is based on examining the methodology stated in legal documents, the evolution of the Russian system of countering the financing of terrorism, the practices, and the problems they generates.

### **2. SHORT REVIEW OF THEORY**

There are several theories trying to explain the macroeconomic causes of terrorism:

1. Uneven development of the world economy. Ackoff (2003) believes that there is the one way to reduce terrorism - to promote the development of societies that breed terrorists. Only through the alignment and increase of the level and quality of life is possible to come to the elimination of terrorism. The tool is in many ways idealistic, but there is no other one, and a number of UN programs are still working in this area.
2. Distortions in the distribution of funds within a particular country as a special case of the first reason. To eliminate this cause de Soto (1989) suggested the economic theory of "leakage" - transferring a part of the financial benefits received by large business to the



small business and consumers. Governmental programs on the small business support can be considered as practical actions to implement this idea.

3. The uprising of poor Muslims against the rich Christian world. The theory has been criticized, but the very topic of religious confrontation has not gone from the agenda (Precht, 2007).

### **3. MAIN PROVISIONS AND RESULTS**

#### **3.1. Methodology of solving the problem of financing terrorism in Russia**

The methodological fundamentals for solving the problem of terrorism in Russia are contained in (FATF, 2012-2018) and (FATF, 2013-2018) and in The Concept of Development of the National System of Countering the Legalization (Laundering) of Proceeds of Criminal Activity and the Financing of Terrorism (President of Russian Federation, 2018). The main elements determined by these documents are the basic terms and concepts, principles and measures of counteraction. Developers of the documents mentioned above assume that risk is a derivative of three factors: threats, vulnerabilities, and the consequences of identification particular threats of the financing of terrorism: 1) A threat is a person or a group of persons (terrorist, terrorist group, their supporters), an object (their money), as well as any activity (on financing terrorism) having no statute of limitations which can potentially harm the state. 2) In the context of the counteraction against terrorism, vulnerabilities are considered separately from the threats and include areas in which the threat can be realized (the financial system in the broad sense) or mechanisms that can facilitate its implementation (facilities used for transfer and storing money). 3) Risks are understood as the result of certain factors' impact in the counteraction against legalization (laundering) of proceeds of criminal activity crime and the financing of terrorism. These factors include: ineffective control; specific characteristics of the country; features of a particular activity and sector of the economy, financial product or service, which are attractive for the purposes of financing terrorism. 4) Consequences are considered as the results of the negative impact (harm) on the economy of the country, and on society as a whole, from the criminal activities of funded terrorist individuals (groups). The principles on which the Russian system of countering the financing of terrorism is based are the principles of international law, the principle of expanding the participation of the Russian Federation in international cooperation in this field, the principle of equal participation of member states in the system of counteraction, the principle of using outrun regulatory tools (risk-oriented approach, unified information system, quantitative criteria of the national system effectiveness, development of the professional training). The measures used to counter threats are divided into three groups: political, legal and operational. At the same time, there are no economic measures provided. An analysis of the now-day Russian system of countering the financing of terrorism allows finding out a number of theoretically unresolved issues. Firstly, the problem of objective setting. The macroeconomic regulation should correspond with the Tinbergen's rule (Tinbergen, 1952) which states that the number of objectives in the objective function of regulation should not exceed the number of tools in disposal to implement the policy. Its economic meaning constitutes in the fact that the legislator and the government should not take the responsibility on what they are not able to implement. The fight against terrorism leads to increasing number of direct and indirect opponents, which, in turn, makes it necessary to increase efforts to protect potential targets from terrorism attacks. An increase in protected objectives, in turn, leads to the need to increase the engaged resources and tools in the short and medium terms. The only explanation is that the more states are officially involved in the fight, the lower are the risks of terrorists' counteraction for each separate state in the long term. Secondly, the problem of the object for analysis. Today, terrorism (and its financing schemes) is represented not by isolated small groups but by the established network structure.

Special services and security forces are now adapting to combat these network communities. At the same time, an economic approach should be used, since today terrorist organizations can be considered and analyzed as business structures managing their assets. Thirdly, the problem of resolving the contradiction between the necessity of international efforts to overcome terrorism as a global problem, and the interests of particular state. It is primarily about the economic contribution to general programs from the standpoint of costs and benefits. Fourthly, the problem of budgetary expenditures. The principle known in economics – “marginal costs are necessary to marginal deterrence” (Stigler, 1970, p. 527) means that the stronger protection of the rule of law, the more pressure is created for law-abiding citizens who are forced to maintain the execution of the law at their own expense, and also to endure a lot of unpleasant police-bureaucratic procedures designed to prevent potential offenses. The task of optimum protection of the rule of law is not solved yet.

### **3.2. Russian practice of countering the financing of terrorism**

The structure of the Russian system countering the financing of terrorism includes special services - Federal Financial Monitoring Service (Rosfinmonitoring), law enforcement agencies (Federal Security Service of the Russian Federation, Investigation Committee, Ministry of Internal Affairs of Russian Federation) and the Central Bank of Russia as the core of this system. Russian counteraction system went through several stages of its formation.

The first stage - institutionalization – included: 1) adoption in 2001 of a special law on countering the legalization (laundering) of criminal proceeds and the financing of terrorism, and then more than 20 federal laws in this area, which increased the effectiveness of activities, including through its compliance with international standards; 2) working out by the Russian side the UN Security Council Resolutions aimed at curbing the financing of terrorists through the illegal trade in oil and oil products, precious metals and cultural values, as well as countering terrorist organizations; 3) establishing in 2001 the special federal executive body authorized to counteract the legalization (laundering) of criminal proceeds from crime and the financing of terrorism, as well as coordinating the activities of other executive bodies in this area - the Committee of monitoring (since 2004 - Federal Financial Monitoring Service).

The second stage is the international recognition. Distinguishing of this stage is based on: 1) exclusion of the Russian Federation in 2002 from the list of countries and territories not participating in the fight against legalization (laundering) of proceeds of criminal activity, admission in 2003 to the permanent members of FATF, 2) supporting in 2004 the Russian initiative on the creation of Eurasian group on combating money laundering and financing of terrorism (EAG); 3) successful annual passing a mutual assessment of the Russian system of countering the legalization (laundering) of criminal proceeds and the financing of terrorism compliance with international standards, conducted by experts of FATF, EAG and the Committee of Experts on the Evaluation of Anti-Money Laundering Measures and the Financing of Terrorism (MONEYVAL), 4) defense of the reports on FATF, EAG and MONEYVAL Plenary sessions.

The international operation Barrier, carried out on the methodology developed in Russia, made it possible to identify dozens of individuals at high risk of connection with terrorist activities, and they are included in the national lists of terrorists. As the result of joint work with international structures a number of so-called shadow plots were eliminated and schemes for servicing questionable cash flows of tens of billions rubles were identified.

The third stage is self-development which manifests in the development of new institutional solutions and creation of organizational structures — the Inter-Agency Commission on Counteracting the Legalization of Proceeds of Criminal Activity and Financing of Terrorism, the International Training and Methodological Center for Financial Monitoring, the Network university for professional training.

Analysis of the practice of countering terrorism allowed identifying a number of problems in the organization of this activity. The main one is that any major changes in the rules of the game for the system of counteraction affect all participants: businesses, the regulator, and the law enforcement. For credit institutions as an object of regulation difficulties are related with the following: 1) necessity to comply with rigid formal requirements to the mandatory control of bank customers; 2) growth of additional costs for the compulsory control of operations implementation, with the simultaneous increase of the volume and complexity of the operations under control; 3) complicated internal procedures including growing document circulation due to the documents' passing and coordination with the Bank of Russia, as well as with the obligation to control real estate transactions. For clients of the financial sector (individuals and legal entities), the difficulties are due to the potential threat that their transactions may be considered suspicious. Moreover, for several regulatory positions the Russian legislator has "surpassed" the FATF requirements, for example, introduced mandatory monitoring of cashless circulation of precious metals and jewelry products, twice reduced the threshold of the customer's identification for cash turnover of precious metals and jewelry products, and made such identification mandatory for non-cash turnover. For the regulator the organization of work supposes resolving an objective contradiction between the reduction of regulatory pressure on business that is the goal of Rosfinmonitoring, and the need to protect the interests of the state. A paradoxical technical precedent arose: the supervisory authority had previously made claims for non-timely reports, and now for overly conscientious attitude to this issue. Some credit organizations received reprimands for too frequent notifications about customer's checks on the Rosfinmonitoring black list. For law enforcement agencies, there are also some difficulties in the work on countering the financing of terrorism: 1) a large number of sources of financing, both illicit (illegally mined diamonds, human trafficking, counterfeiting, credit cards) and legal (committees for support of particular countries, sponsor-states), which does not allow them to be quickly revealed; 2) a variety of schemes for delivering money to participants of transactions (e-commerce shops, hawala system, banks, travel agencies, gambling houses); meanwhile, the risks connected with financial technologies are growing, since crypto currencies, as a side effect, ensure the anonymity of illegal operations; 3) risks of the possible use of non-commercial entities, as well as public and religious associations for organizing channels of financing terrorist organizations; 4) low quality and reliability of information on the financing of terrorist activities received from both officers of the Ministry of Internal Affairs of Russia and employees of the Bank of Russia, which leads to immobilization of significant forces and means; 5) intensification of migration, potentially carrying the threat of penetration of radical Islamic propaganda into Russia; 6) the lack of proper organization of interdepartmental, especially international interaction, due to insufficient experience in this area of law enforcement and regulatory agencies. According to Razumova (2016), in the Russian economy, areas of activity characterized by a high proportion of significant amounts of cash payments from individuals, and having, therefore, high risks of money laundering and terrorist financing, are revealed. The search for these problems solutions resulted in proposals for developing a strategy to counter the financing of terrorism. The first is efforts to achieve macroeconomic shifts, including: decriminalization and development of mechanisms to counter risks to the real sector of the economy and ensuring the budget system sustainability through the safety of the budgets of all levels.

The second is interstate work: building up anti-terrorist cooperation (President of Russian Federation, 2009) both at the political level and at the level of special services, in order to identify specific countries, business structures and individuals “embedded” in economic ties with terrorism; fuller use of the potential of existing multilateral mechanisms in this area, strengthening results-oriented interaction; establishing trade and economic embargo for territories under the control of terrorists, in accordance with Art. 41 of the UN Charter, which provides for sanctions against its violators; active participation of the relevant departments of the Ministry of Foreign Affairs of Russia and Rosfinmonitoring in conducting FATF studies, the purpose of which is to disclose the sources of funding for terrorist structures.

The third is the monitoring of operations with cash and other assets, which supposes the achievement of: of financial institutions transparency; effectiveness of detecting criminal incomes and informing the authorized body about them. Going into the “shadow” is a potential source of financing of terrorism. In add to the existing analytic tools new methods should be developed - innovative methods of analysis and forecasting, high-intelligent detection systems, methods of indirect assessment of the economic situation. For example, Rosfinmonitoring jointly with the largest banks has formed a model of terrorist financial behavior.

The fourth is the operational work to identify the facts of financing terrorism and the activities of individuals (organized groups) involved in the mechanisms of such financing. It is necessary to proceed from the fact of the strengthening of the link between terrorism and the shadow economy.

The fifth is training. The fundamental point of such training is the formation of new competencies for students in law and economics based on interdisciplinary approach and expansion of inter-sectoral interaction. Creation of new network institute can serve the organizational decision.

#### **4. CONCLUSION**

The counteraction against terrorism is a “classical” problem (and not a task), since it does not have guaranteed effective instruments for resolution. And if there are no working tools, it means that an understanding is needed of the adopted - and most importantly, used today - methodology for solving this problem. In turn, such a methodology should be objectively predetermined by the analysis and identification of the causes of terrorism. Actually, the object of discussion should be not just countering the financing of terrorism, but the measures for undermining the economic foundations of terrorism. During the period of its existence, Russian system of counteraction against financing of terrorism has gone through several stages, having received institutional formalization, international recognition and self-development mechanisms. Four fundamental problems of the adopted methodology are in the objective setting, determination of the object of analysis, “classic” costs-benefits problem and the problem arising from the practice of countering terrorism which manifests in complicating the licit activities of law-abiding entities and forcing them to change their behavior. Measures aimed at improving the practice of countering financing of terrorism should comprehensively cover the macroeconomic level, the system of interstate co-operation, monitoring of financial operations, operational work and changes in the system of personnel training.

#### **LITERATURE:**

1. Ackoff, R.L. & Strumpfer, J.P. (.2003). Terrorism: A Systemic View. *Systems Research and Behavioral Science*, 20(3), 287–294.
2. de Soto, H. (1989). *The Other Path*. New York, New York: Harper & Row Publishers, Inc.

3. FATF (2012-2018). International Standards on Combating Money Laundering and the Financing of Terrorism & Proliferation, FATF, Paris, France, [www.fatf-gafi.org/recommendations.html](http://www.fatf-gafi.org/recommendations.html)
4. FATF (2013-2018). Methodology for Assessing Compliance with the FATF
5. Recommendations and the Effectiveness of AML/CFT Systems, updated October 2018, FATF, Paris, France, [www.fatf-gafi.org/publications/fatfrecommendations/documents/fatfissuesnewmechanismstostrengthenmoneylaunderingandterroristfinancingcompliance.html](http://www.fatf-gafi.org/publications/fatfrecommendations/documents/fatfissuesnewmechanismstostrengthenmoneylaunderingandterroristfinancingcompliance.html)
6. Precht, T. (2007). Home grown terrorism and Islamist radicalisation in Europe. [http://www.justitsministeriet.dk/sites/default/files/media/Arbejdsomraader/Forskning/Forskningspuljen/2011/2007/Home\\_grown\\_terrorism\\_and\\_Islamist\\_radicalisation\\_in\\_Europe\\_-\\_an\\_assessment\\_of\\_influencing\\_factors\\_\\_2\\_.pdf](http://www.justitsministeriet.dk/sites/default/files/media/Arbejdsomraader/Forskning/Forskningspuljen/2011/2007/Home_grown_terrorism_and_Islamist_radicalisation_in_Europe_-_an_assessment_of_influencing_factors__2_.pdf) [In Russian]
7. President of Russian Federation (2009). On the National Security Strategy of the Russian Federation up to 2020. Decree of the President of Russian Federation. May 12, 2009, № 537 <http://pravo.gov.ru/proxy/ips/?docbody=&nd=102129631> [In Russian]
8. President of Russian Federation (2018). The concept of development of the national system of countering the legalization (laundering) of proceeds of criminal activity and the financing of terrorism. 30.05.2018. <http://kremlin.ru/supplement/5310> [In Russian]
9. Razumova, I.V. (2016). Combating money laundering and the financing of terrorism: interrelation of requirements of international standards and Russian reality. Finance and credit, 37(709), 2-13. [In Russian]
10. Stigler, G. J. (1970). The Optimum Enforcement of Laws. Journal of Political Economy, 78(3), 526-536
11. Tinbergen, J. (1952). On the Theory of Economic Policy. North-Holland Pub. Co.

## YOUTH AND THE LABOUR MARKETS IN THE EUROPEAN UNION

**Roman Klimko**

*University of Economics in Bratislava, Faculty of National Economy,  
Dolnozemska 1, 852 35 Bratislava  
roman.klimko@euba.sk*

**Eva Rievajova**

*University of Economics in Bratislava, Faculty of National Economy,  
Dolnozemska 1, 852 35 Bratislava  
eva.rievajova@euba.sk*

### **ABSTRACT**

*Young people have been hit harder by the recession than any other age group, and, moreover, the subsequent economic growth has not been accompanied by sufficient job creation that is suitable for young people. This is despite the fact that today's young people are the most educated generation in history. The current situation of young people has significant economic, political and social consequences. With insufficient public support, declining household incomes increase the risk of poverty. In recent years, the NEET indicator has been used to a greater extent. The reason was the group so-called discouraged young people who are not captured in the unemployment indicator according to the standard definition of unemployment. So, it is not about young people who want to work while actively looking for job - in other words, discouraged young people. Attention has begun to focus on the NEET indicator, as it has several advantages over the unemployment rate. The main objective of the paper is to analyse recent trends in youth unemployment and it seeks to identify the main issues related to youth unemployment and joblessness that need to be solved.*

**Keywords:** *European Union, NEET, Unemployment, Youth*

### **1. INTRODUCTION**

Young people are a disadvantaged group in the labour market as youth unemployment rates generally tend to be much higher than for the overall population, in some countries more than twice as high. Since the financial crisis, both overall and youth unemployment rates have risen in all member states of the European Union. However, youth unemployment is hardly a new phenomenon appearing only in the aftermath of the financial crisis. Most EU countries currently struggling with the integration of young people into the labour market had seen high levels of youth unemployment even before the financial crisis struck. The issue has only deepened and become more visible since then. The unemployment rate among young people varies greatly between EU countries. Looking at average unemployment rate across the EU, different trends can be seen in the last decade. Although youth unemployment stood at 16.8% in 2017, having just slightly increased since 2007 when it stood at 15.5%, nevertheless a sharp rise was reported between 2008 and 2009. During the subsequent stagnation in 2010-11, the situation deteriorated further and no positive developments were seen until 2014, when the youth unemployment rate started to fall gradually. The lowest youth unemployment rates (Figure 1) can be found in Germany (6.8%), followed by the Czech Republic (7.9%), the Netherlands (8.9%) and Austria (9.8%), while the highest are recorded in Greece (43.6%), Spain (38.6%) and Italy (34.7%). These high youth unemployment rates indicate the financial crisis to have especially impacted young people, with the subsequent economic growth not accompanied by the creation of enough jobs suitable for young people. This is despite today's youth being the most educated generation in history. As a rule, young people work in lower-quality jobs, often enter into temporary employment contracts with their employers and earn less than older workers.

The current situation they face has significant economic, political and social consequences. Insufficient public support capped with declining household incomes has put ever more people at risk of poverty. Young people and their families are willingly or unwillingly forced to reduce their basic spending on food, housing and healthcare, with a consequent effect on their overall well-being and health. A study conducted by the OECD (2015, p. 33) notes that periods of inactivity and unemployment in early adulthood have permanently negative effects on future employment and income. Carcillo et al. (2015, p. 49) believe that the growing uncertainty with which young people are grappling at the beginning of their careers may also be preventing them from reaching levels seen in traditional indicators of adulthood, such as ensuring permanent employment. A steady job is typically associated with the decision to leave their parents' home and is usually a prerequisite for starting a family. Over the long term, inactivity and unemployment can lead to isolation and loss of contact with society, with adverse effects on health, fertility and trust, and it can also lead to crime activities. The main objective of the paper is to analyse recent trends in youth unemployment and it seeks to identify the main issues related to youth unemployment and joblessness that need to be solved.

## **2. YOUTH UNEMPLOYMENT IN THE EUROPEAN UNION**

The youth unemployment rate responds both to the economic cycle and to the institutional setting and characteristics of the labour market. Notwithstanding, the impact of these factors may be different for youth and adult unemployment (Ghoshray et al., 2016, p. 8). Ryan (2001, p. 87) notes that youth unemployment tends to be markedly cyclical, and so more sensitive to the economic cycle than adult unemployment. Certain specificities of youth unemployment can explain the sensitivity of youth unemployment to the economic cycle, such as the concentration of young people employed in cyclically sensitive sectors and in small and medium-sized enterprises (Scarpetta et al., 2010, p. 14). It is primarily the role of the European Union's member state governments to address youth unemployment. Notwithstanding, the European Union is also endeavouring to support them in their efforts, including through the Youth Guarantee and Youth Employment Initiative (YEI). As early as its Communication of 28 November 2012 on the 2013 Annual Growth Survey, the European Commission has emphasised the need for member states to provide their youth with the opportunity to transition from school to employment, as well as to develop and put a system in place to guarantee people under 25 a job offer, further education, apprenticeships or internships within four months of completing formal education or losing a job. Subsequently, the Council of the European Union recommended on 22 April 2013 for EU member states to introduce a guarantee for young people. Further education could include high-quality vocational programmes that would lead to a recognised professional qualification.

*Figure following in the next page*

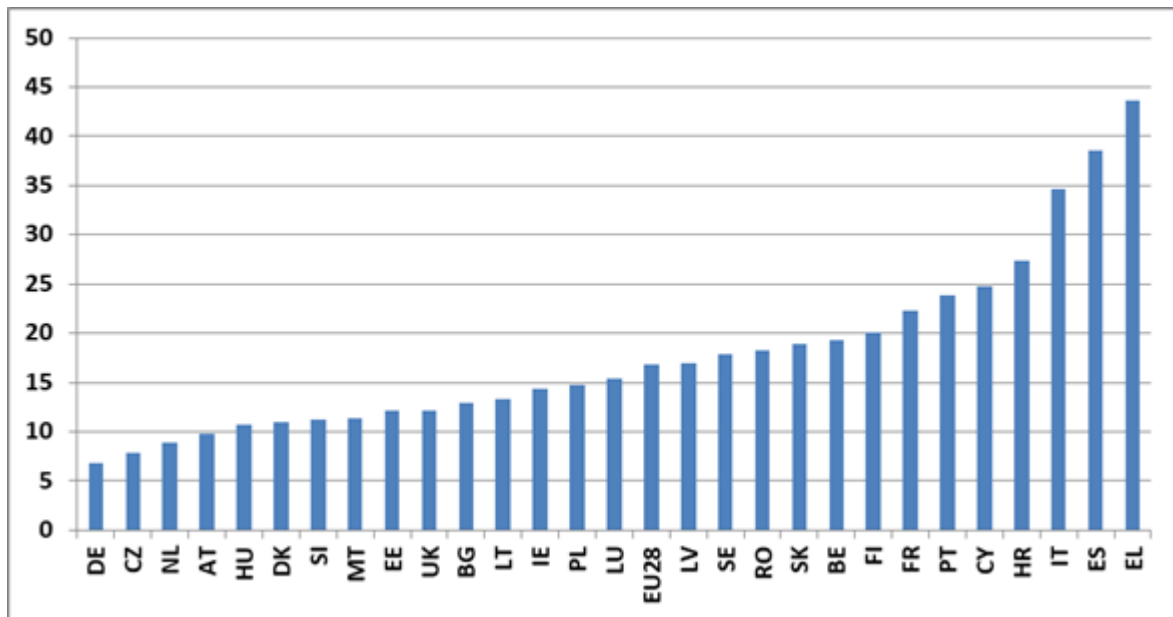

Figure 1: Youth unemployment rate (age group 15-24 years, year 2017, in %) (Eurostat)

The Youth Employment Package proposed by the European Commission on 5 December 2012 follows up on youth-related measures set out in the broader employment package and focuses on the following priorities:

- Proposing the creation of a *Youth Guarantee* by European Union member states;
- Consulting with social partners to create a good framework for internships; and
- Establishing the European Alliance for Apprenticeships and finding ways to remove mobility obstacles for young people.

On 8 February 2013, the European Council passed a resolution to appropriate €6.4 billion to establish the Youth Employment Initiative for 2014-20, with the aim to strengthen and accelerate the measures established in the Youth Employment Package. The purpose behind the Initiative is primarily to provide support for young people not in education, employment or training (NEETs) in regions whose youth unemployment rate is greater than 25%. The Youth Employment Initiative is the European Union's main programme for facilitating the roll-out of the Youth Guarantee. In 2016, increased funding was announced and it was replenished in 2017. For the current period running for 2014-20, the budget is €8.8 billion. This will bring support to even more young people. Interim results in the current period indicate significant improvement in the situation. The youth unemployment rate fell from its peak in 2013 of about 24% to the current level of 16.2% in 2017, faster than the decline in overall unemployment and the decrease projected by macroeconomic trends. The proportion of people aged 15-24 not in education, employment or training dropped from 13.2% in 2012 to 10.9% in 2017. In absolute numbers, there were 2.3 million less unemployed youth in the European Union than in 2013 and 1.4 million less youth NEETs.

Figure following in the next page



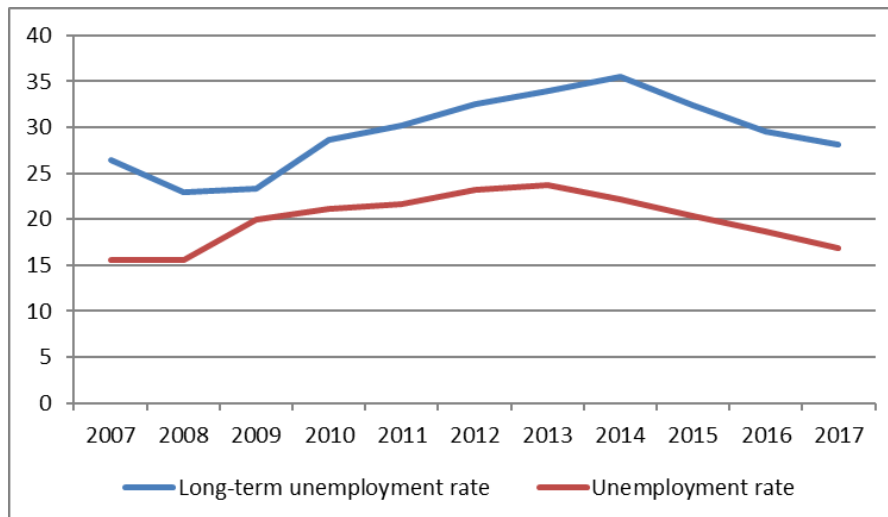

Figure 2: Youth unemployment rate and youth long-term unemployment rate  
(age group 15-24 years, in %)  
(Eurostat)

A short period of unemployment during the young people transition from the education system to the labour market cannot be considered as unexpected. After graduating from school, they have to find their own way in the labour market. In many cases, this transition will require them to revise their labour market expectations, search for a job they like and choose a career that will satisfy them in future. While a short period of unemployment in a young man or woman's career will not impair a career, long-term unemployment can leave lifelong consequences and have a significantly negative impact on employability and future prospects (Gregg, 2001, p. 638). Viewed from the perspective of the causes and effects of long-term unemployment, the effect is contingent on the individual level of skills, with a lasting adverse effect on the low-skilled, but not on individuals with mid- or high-level qualifications (Burgess et al., 2003, p. 303). Similarly, Gregg (2001, p. 636) estimated the future presence of unemployment from the unemployment rate among young people and found that an additional three months of unemployment for a person under 23 led between age 28 and 33 to a lengthening of the unemployment spell to 1.3 months. Long-term unemployed youth accumulate less work experience, devaluing their skills. Future job prospects are even more limited if they have less experience, which can subsequently lead to lower future earnings. Gregg and Tominey (2004, p. 2) estimated that an unemployed youth would see his or her income reduced 12-15% by age 42. The above findings suggest disengagement from the labour market not to be a temporary problem. An extended period of unemployment is likely to bring lifelong negative consequences, such as a job paying a lower wage, unstable employment, and generally fewer opportunities. There are some specific obstacles preventing access by young people to the labour market (Eurofound, 2017, p. 50). The first of these barriers is lack of prior professional experience. Another is considered to be the general shortage of opportunities for them in the current labour market, especially in those countries hit by the financial crisis the hardest. Some member states of the European Union have a relatively low number of long-term unemployed youth, while it is exactly the opposite in other countries where a large number of young people have been unemployed for more than 12 months, particularly reflecting the general shortage of job opportunities in these countries. France, Italy and Spain are the countries that particularly fall in this category and any action they take has to target large groups of young unemployed people. Living in a rural or specifically disadvantaged area can also be seen as a major barrier. According to traditional neoclassical models, migration should reduce regional differences. Mazúrová and Kollár (2017, p. 454) conclude that the mobility and its determinants, as well as

penetration in relation to the labour market at national or regional level and related implications for economic practice, are in the centre of attention in a number of studies. A young person from a foreign country or with a migrant background may face yet another obstacle. In addition, these problems are further multiplied for those young people who are entering the labour market disadvantaged for several reasons. Recent years have seen NEET used to a greater extent in order to capture the so-called “discouraged young people” missed by indicators which track unemployment according to the standard definition. These are not youth who would like to work and are actively looking for a job, but rather young people dissuaded from seeking employment. More attention is starting to be paid to NEET because the indicator has several advantages over the standard unemployment rate used, as O’Higgins (2015, pp. 7-8) asserts. First of all, it should be stressed that the unemployment rate is an indicator that cannot always provide a reliable picture of the scope of problems young people encounter in the labour market, since they concern all youth of this age, not just those unemployed according to the standard definition. If a majority of young people under age 24 are more or less receiving an education and when entering the labour market, they are unemployed, the youth unemployment rate will skew very high, but then it would be only a relatively minor problem, considering the total number of young people in a country. But on the other hand, the unemployment rate does not take the entire labour market into account, especially among the young. Youth unemployment does not include those who wish to be employed, but are not seeking a job because they know or believe there is nothing suitable available to them – the “discouraged” ones. This becomes a key issue during recessions. The number of discouraged workers is not dependent on economic or personal circumstances. People may stop looking for work because they either know or believe that no suitable work is available. When this happens, they instantly disappear from statistics and become temporarily or permanently excluded, which may cause them to be classified among the apathetic in the population. And what about those who have noticed current labour market conditions and so decided instead to have children, take care of them, enjoy their leisure time, travel or participate in lifelong learning? Ultimately, all of these discouraged young people represent untapped potential both from an individual perspective as well as from that of society. Given the particular problems which are associated with employment services unable to mobilise discouraged individuals, particular attention has to be paid to the following groups:

- Young people not captured by traditional unemployment rate indicators; and
- Youth not in education, employment or training.

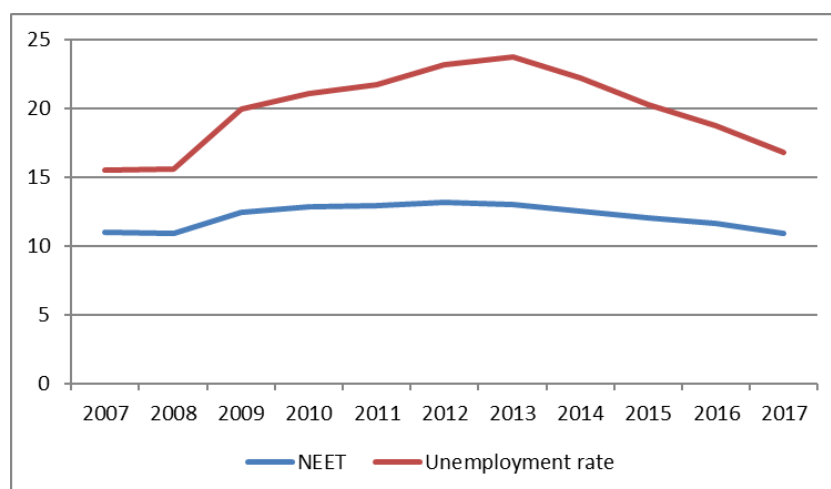

Figure 3: Youth unemployment rate and NEET indicator (age group 15-24 years, in %) (Eurostat)

### **3. POLICIES TARGETING YOUTH UNEMPLOYMENT**

So, what would be the appropriate response to a high youth unemployment rate? First of all, there needs to be awareness that any policy encouraging the employment of young people has to be based on an economic policy which generally promotes economic and employment growth. Secondly, experience shows a more flexible labour market in itself not to be enough, so passing employment protection legislation, for example, is in all likelihood not going to solve the problem of youth unemployment. On the other hand, a well-run education and training system can greatly facilitate access by young people to the labour market in the longer term. O'Higgins (2015, p. 14) argues that policies properly designed to increase the level of education among young people will probably enhance economic growth and, at an individual level, clearly lead to improved chances of finding work and earning an income. He also notes that one of the options for helping youth is to take active labour market measures, characterising its efficiency by the type of measure, the particular point in the economic cycle, the population group targeted and the timing of evaluation and involvement of social partners. In terms of type, active labour market measures include comprehensive labour market action that combines supported employment, training, self-employment support and counselling. Such comprehensive action has been successful in many countries. Job search assistance and improvements to it are considered the most cost-effective of all active labour market measures (Fay, 1996, p. 27), but this approach applies only when there are enough vacancies available. There is less probability for this type of action to be effective in recessionary periods. Other effective measures concentrate on employer training, especially by private-sector employers. Accordingly, it is important to distinguish between on-the-job and off-the-job trainings. On-the-job training provided at the workplace with direct employer contact is more effective. As mentioned earlier, measures somehow interconnected with the private sector tend to operate better than in the public sector. From the perspective of the economic cycle and the impact of active labour market measures, training seems to be less effective during a recession, especially when compared with other measures such as financial support for employment. In recessionary periods, emphasis should be placed on financial support for employment alongside other job-creation and income-support measures. However, an analysis of labour market measures conducted by Kluge (2010, p. 915) showed them to have worked much better as a whole when unemployment was higher, adding that the effect is even greater and more statistically significant when attention is reduced to just educational programs. He explained it by noting, in times of recession, for the pool of potential education programme candidates to be of above average quality. Targeting is generally seen to be negative, based on assessments made of active labour market measures for young people (Card et al., 2009, p. 462), while Betcherman et al. (2007, p. 13) mentions that measures targeting disadvantaged young people seem to be more effective. Fay (1996, p. 22) also notes targeted measures to be more effective. Although there have been few studies at least marginally concerned about the impact of social partners in how effective active labour market measures will be, a general consensus exists that their participation would probably make individual measures more effective. Many studies show measures closely focused on private-sector employees to be more effective. Employers can utilise a variety of active labour market measures in order to recruit and/or review employees.

### **4. CONCLUSION**

The economic crisis of recent years has had a particularly adverse effect on youth employment. The period was characterised by a dramatic decline in employment rates across the European Union and a sharp rise in unemployment rates both as a standard and NEET indicator. General recommendations reflecting the serious consequences the long-term unemployment can bring and the effort to integrate long-term unemployed youth into the labour market include primarily having public employment services register them and an in-depth assessment of the individual

needs of young people. Subsequently, the emphasis has to be on a tailored approach taking a job seeker's characteristics and needs into account. It is also important to recognise that long-term unemployment does not have the same impact on each young person and that long-term unemployed youth or young people indicated as NEETs typically have specific needs and characteristics different from those found in other unemployed people. Lack of education and of work experience are two major factors raising the probability of a young person becoming unemployed. Reintegrating long-term unemployed youth is a real challenge which has to be addressed across the entire European Union.

**ACKNOWLEDGEMENT:** *The paper is the outcome of scientific project VEGA No. 1/0001/16 'Present and prospects of changes in employment and related processes in the context of achieving the objectives of the European Employment Strategy'.*

#### **LITERATURE:**

1. Betcherman, G., Godfrey, M., Puerto, S., Rother, F., Stavreska, A. (2007). *Global inventory of interventions to support young workers: Synthesis report*. Washington, D.C.: World Bank.
2. Burgess, S., Propper, C., Rees, H., Shearer, A. (2003). The class of 1981: The effect of early career unemployment on subsequent unemployment experiences. *Labour Economics*, Vol. 10, No. 3, pp. 291-309.
3. Carcillo, S., Fernández, R., Königs, S., Minea A. (2015). *NEET Youth in the Aftermath of the Crisis: Challenges and Policies*. No. 164, Paris: OECD Publishing.
4. Card, D., J. Kluve, J., A. Weber. (2010). Active labour market policy evaluation: A metaanalysis. *Economic Journal*, 120(548), pp. 452-477.
5. Eurofound. (2017). *Long-term unemployed youth: Characteristics and policy responses*. Luxembourg: Publications Office of the European Union.
6. Fay, R.G. (1996). *Enhancing the effectiveness of active labour market policies: Evidence from programme evaluations in OECD countries*. *Labour Market and Social Policy Occasional Papers*. No. 18, Paris: OECD.
7. Ghoshray, A., Ordóñez, J., Sala, H. (2016). Euro, crisis and unemployment: Youth patterns, youth policies? *Economic Modelling*. Elsevier, vol. 58(C), pp. 442-453.
8. Gregg, P. (2001). The impact of youth unemployment on adult unemployment in the NCDS. *Economic Journal*. Vol. 111, No. 475, pp. 626-653.
9. Gregg, P., Tominey, E. (2004). *The wage scar from youth unemployment*. *CMPO Working Paper Series*. No.04/097, Bristol: University of Bristol.
10. Kluve, J. (2010). The effectiveness of European active labor market programs. *Labour Economics*. 17(6), pp. 904-918.
11. Mazúrová, B., Kollár, J. (2017). *Labour mobility in household decision-making on time allocation*. Retrieved 20.10.2018 from <http://www.etap.umb.sk/>.
12. O'Higgins, N. (2015). *Youth unemployment*. IZA Policy Paper No. 103. Retrieved 17.10.2018 from <http://ftp.iza.org/pp103.pdf>.
13. OECD. (2015). *Tackling Harmful Alcohol Use – Economics and Public Health Policy*. Paris: OECD Publishing.
14. Ryan, P. (2001). The school-to-work transition: a cross-national perspective. *Journal of Economic Literature*. 39 (1), 34-92.
15. Scarpetta, S., Sonnet, A., Manfred T. (2010). *Rising youth unemployment during the crisis: how to prevent negative long-term consequences on a generation? OECD Social, Employment and Migration Working Papers*. No. 106, Paris: OECD Publishing.

## THE RELEVANCE AND DISTRIBUTION OF CERTIFIED B CORPORATIONS IN THE EUROPEAN UNION ECONOMY

**Sabina Lacmanovic**

*Juraj Dobrila University of Pula, Faculty of Economics and Tourism "Dr. Mijo Mirković",  
Preradovićeva 1, Croatia  
srgor@unipu.hr*

**Dario Milec**

*Juraj Dobrila University of Pula, Faculty of Economics and Tourism "Dr. Mijo Mirković",  
Preradovićeva 1, Croatia  
dmilec@unipu.hr*

### ABSTRACT

*The origins of B Corp movement date back to 2007 when a non-profit organization B Lab introduced the B Corp certificate in the USA. The first B Corporations (the for-profit Corporations Beneficial to society) were certified in 2007. Since then 2655 companies in 60 countries around the world across 150 industries have been certified. The European B Corp movement, officially launched in 2015 with 60 companies, has now grown to more than 500 B Corps. The purpose of the paper is to elaborate the motivation behind the B Corp certificate, its application process and its effects on the customers, regional economies, and employee candidates. The authors analyse the growing presence of certified B Corporations in the European Union, its distribution across EU countries, and across different industries, and debate its advantages and shortcomings. The companies reach for B Corp certificate to visibly differentiate themselves, to protect their mission and to measure and improve their social and environmental performance/impact. However, the certificate recognizability is still to be further developed, especially in countries where B Corp certification has not yet taken place. The authors elaborate the pro and contra of the certification process (its transparency, the review and verification processes, and its recertification character). The paper is based on the desk research method (secondary data used in the paper are based on B Lab statistics) and on the critical analysis approach to the theme-relevant papers and research studies. The results indicate that the value of B Corp certificate is not fully realized in the modern EU economy, mostly because of a lack of knowledge and awareness on its effects. There is also an evident lack of academic papers on this subject. This paper's aim is to fill that gap. The conclusions given in the paper could be a valuable input for future primary research.*

**Keywords:** *B Corporations, certification process, European Union, impact*

### 1. INTRODUCTION

The origins of B Corp movement date back to 2007 when a non-profit organization B Lab introduced the B Corp certificate in the USA. The first B Corporations (the for-profit Corporations Beneficial to society) were certified in 2007. Since then 2655 companies in 60 countries around the world across 150 industries have been certified. The European B Corp movement, officially launched in 2015 with 60 companies, has now grown to more than 500 B Corps. The purpose of the paper is to elaborate the motivation behind the B Corp certificate, its application process and its effects on the customers, regional economies, and employee candidates. The authors analyse the growing presence of certified B Corporations in the European Union, its distribution across EU countries, and across different industries, and debate its advantages and shortcomings. The companies reach for B Corp certificate to visibly differentiate themselves, to protect their mission and to measure and improve their social and environmental performance/impact.

However, the certificate recognizability is still to be further developed, especially in countries where B Corp certification has not yet taken place. The authors elaborate the pro and contra of the certification process (its transparency, the review and verification processes, and its recertification character). The paper is based on the desk research method (secondary data used in the paper are based on B Lab statistics) and on the critical analysis approach to the theme-relevant papers and research studies. The results indicate that the value of B Corp certificate is not fully realized in the modern EU economy, mostly because of a lack of knowledge and awareness on its effects. There is also an evident lack of academic papers on this subject. This paper's aim is to fill that gap. The conclusions given in the paper could be a valuable input for future primary research. The paper is elaborated in 6 chapters. The introductory chapter is followed by the chapter 2 where the motivation for introducing the B Corp certificate is presented. In the chapter 3 the authors discuss the pro and contra of the certification process and its trustworthiness. The relation to the legal structure »benefit corporation« and its equivalents is also addressed. The following chapter 4 analyses the benefits and impact of B Corp certificate on the modern economy and society. The chapter 5 represents a central empirical part of the paper where the distribution of certified B corporations in the European Union economy is analysed and commented. The research results are followed by the concluding remarks and bibliography list.

## **2. THE MOTIVATION FOR INTRODUCING THE B CORP CERTIFICATE**

The negative impacts of traditional corporations cause a still on-going debate about the purpose and responsibility of a corporation. The insights from this discussion have led to the proposition and creation of new legal structures which brought together business success and social good. However, the legislation takes time to be developed and adopted, and it is often state-limited. Therefore, independent of the legislative initiatives and parallel to that process, a new business certification system was introduced to recognize impact-driven companies: B Corporations (B Corps). A non-profit organization B Lab, aware of the time-consuming efforts in passing the new legislation for Benefit Corporation which they proposed and developed, got ahead of the bill enactment, and established a certification system which is not limited by geographic/jurisdictional boundaries. The first B Corporations were certified in 2007, and the first Benefit Corporation bill has been enacted in 2010 (Alexander, 2017a) by the state of Maryland (USA). The Washington state was the first state to pass a Social Purpose Corporation (SPC) bill, which allows companies to commit to one or more social goals. California introduced a similar form, the Flexible Purpose Corporation, along with legislation for Benefit corporations (Rawhouser et al., 2015). Today, the Benefit Corporation structure has been adopted in most U.S. states. In the European Union a similar legal structure, directly modelled after Benefit Corporations from USA, was created in Italy, named »the Società Benefit«, through the »Stability Act of 2016« (Pelatan and Randazzo, 2016, Scuri, 2017). In 2017 the Benefit Corporation Legislation was introduced in the legislature in Argentina, Chile, and Colombia (Alexander, 2017b). Several U.S. states allow also the Benefit LLC (Limited Liability Company). Being certified as a B Corporation is not mutually exclusive with being incorporated as a Benefit Corporation or an SPC. On the contrary, many certified B corporations have adopted legal structures that give stronger legal protection to follow both the economic and social goals (mostly the Benefit Corporation structure). However, the main advantage of a B Corp certificate is that it can be acquired from any legal entity (regardless of corporate structure, state, or country of incorporation), which is a plus in countries where new legal structures have not yet been introduced. B Lab offers Benefit Corporations a free reporting tool to meet their statutory transparency requirements. B Corp is a label that allows a company to verify and demonstrate its beneficial impacts on society and environment through a third-party assessment (B Lab).

Internally, B Corp certification provides a formal framework that can help management make decisions that address environmental and social concerns in a systematic way (NBIS, 2012, p. 3). In its goal of using business as a force for good, B Lab focuses on three initiatives: building a community of Certified B Corporations so one can tell the difference between »good companies« and just good marketing, accelerating the growth of the impact investing asset class through use of B Lab's GIIRS Ratings and Analytics by institutional investors, promoting legislation creating a new corporate form that meets higher standards of purpose, accountability and transparency (NBIS, 2012). The B Lab approach represents a rating and assessment system that integrates aspects of many approaches including GRI (Global Reporting Initiative), HIP (Human Impact + Profit) Scorecard and Framework, LEED Certification (Leadership in Energy and Environmental Design), SROI (Social Return on Investment), SVN and Wiser Earth (Olsen and Galimidi, 2008, p. 20).

### **3. THE B CORP CERTIFICATION PROCESS AND ITS CREDIBILITY**

The B Corp certification is a five-step process. First, applicants complete B Lab's online B Impact Assessment which covers governance (corporate accountability, transparency, governance metrics), workers (worker metrics, compensation, benefits and training, worker ownership, work environment), community practices (job creation, diversity, civic engagement and giving, local involvement, suppliers, distributors and product), environmental practices (facilities, inputs, outputs, supply chain), and consumers. Depending on size (number of employees), complexity, industry sector, and location of primary operation, companies are asked around 200 questions that assess a company's performance across the above mentioned 5 categories (B Lab, 2018a, Olsen and Galimidi, 2008, p. 20). It is a tool publicly available (at no cost) to all organizations which would like to measure and improve their environmental and social impact. The assessment score must be at least 80 points out of 200 for the company to qualify. One of the best ways to earn points on the B Impact Assessment is to formalize the policies and procedure in writing, e.g. by creating an environmental purchasing policy, a local purchasing policy, a community service policy, an employee handbook, a whistle-blowing policy, a code of ethics, a supplier code of conduct, or an external annual report that details organization's mission-related performance (Honeyman, 2014, p. 161). After completing 90 percent of the B Impact Assessment, the company is asked to begin the disclosure questionnaire which allows the company to confidentially disclose to B Lab any sensitive practices, fines, and sanctions related to the company or its partners (B Lab, 2018a). This component does not affect the company's rating, but if B Lab identifies one or more items in the disclosure questionnaire or in a background check of the company and its senior management to be material, the company will be notified to provide incremental disclosure on [www.bcorporation.net](http://www.bcorporation.net). (In certain cases, the company will be required to implement specific remedies to obtain or maintain the certification, and in rare cases the company's certification will be denied or revoked). The next step is an assessment review call with a B Lab staff member. This enables B Lab to make sure questions were answered in the correct manner and calculations performed correctly, considering the unique circumstances and practices of a company. Before this phone call, the company is required to submit supportive documentation which verifies 6 – 15 randomly selected responses. Usually, the most heavily weighted questions are selected for verification (B Lab, 2018a). After the review call additional documentation is usually required to resolve any outstanding question about the answers. After completing these three steps, the company needs to amend its articles of incorporation to reflect the commitment to the vision and requirements as a B Corp to the extent possible in its state. As a final step, the company is requested to sign a simple 2-page term sheet that lays out the expectations for Certified B Corporations. It commits a company to certification fees, the legal framework and to the »Declaration of Interdependence«.

This concludes the process, and if the company has met the criteria, it can officially receive B Corporation certification. Upon certification a company creates a profile for publication on [www.bcorporation.net](http://www.bcorporation.net) which is shown alongside a summary of the B Impact Assessment results. The annual fee for attaining and maintaining the certification status is determined as a percentage of revenue (it varies between 0,01 and 0,05 %, i.e. between 500 and 25,000 \$). Because the B Impact Assessment measures performance over the past 12 months, only companies that have at least one year of operations are eligible for B Corp certification. Companies under one year are eligible for Pending B Corp status. From recently B Lab (2018a) requires that all certified B Corporations must become a Benefit Corporation or adopt SPC-equivalent status within two years after the company's initial certification date (in countries where Benefit Corporation status or SPC-equivalent status is available). The credibility of the certification process is assured through following mechanisms: the verification of processes, practices and source documentation from B Lab staff to confirm consistency of self-reporting; background checks by B Lab staff (a review of public records, news sources, and search engines for company names, brands, executives/founders, etc.); random in-depth site reviews (conducted in-person or virtually) for 10 % of B-certified companies per year to verify the accuracy of all affirmative responses in the B Impact Assessment; public companies and wholly-owned subsidiaries are subject to a mandatory on-site review during each three-year certification term, and are subject to additional transparency requirements; an independent committee of 20-22 members (Standards Advisory Council) oversees B Lab's certification standards; the B Impact Assessment is updated every three years; every three years (as of July 1st, 2018) every B Corp must undertake the re-certification process to prove that it continues to engage in a high level of impact with their stakeholders, even as the business grows or changes (Olsen and Galimidi, 2008; NBIS, 2012; B Lab, 2018a). If the post-onsite review score is lower than 80 points, the company will be given 90 days to recover its points. If the onsite reviewer discovers that a company was intentionally misrepresenting itself on the assessment, the certification can be revoked (NBIS, 2012). The B Corp label does not indicate that a company's impact is only positive, but it does show a company's strong commitment to both economic and social goals. The category as well as sub-category scores reveal areas where significant progress can be made and could serve as a guideline for company's future strategies, policies and practices. The critics of the certificate argue that yearly on-site review at only 10 % of the companies is not enough. However, it must be clearly stated that this certificate, as any other, is not a perfect tool, and does not always guarantee the best possible behaviour, but it is despite its shortcomings in metrics as well as in the verification processes, a significant step towards socially conscious economy. In 2016 B Lab launched the Inclusive Economy Challenge (IEC), an annual call to action for the community of certified B Corporations to improve their impact and move toward an inclusive economy (B Lab, 2018b). The participating B Corps choose three or more metrics (from the B Impact assessment) to improve on, setting goals to achieve over the course of a year. Companies that report at least one improvement, qualify themselves as Inclusive Economy Changemakers.

#### **4. THE BENEFITS OF ATTAINING A B CORP CERTIFICATE AND ITS IMPACT ON THE MODERN ECONOMY AND SOCIETY**

The benefits of B Corp certification could be evaluated from the perspective of the certified corporations, but also from the perspective of its customers, suppliers, investors, workers, and local/regional community and economy (e.g. labour market, government spending etc.). Many certified B Corporations say they use certification as an internal benchmark for continual improvement (NBIS, 2012), while others are motivated by other benefits (Sabeti, 2009, Wilburn and Wilburn, 2015, Roth and Winkler, 2018). Kim et al. (2016) have found two major underlying reasons why firms choose to seek B Corporation certification.



The prevalence of generic CSR efforts in an industry creates the need to »stand out in the midst of a greenwash revolution among large companies«, and the large number of hostile shareholder-centric activities in an industry, such as mass layoffs and high levels of income inequality between top executives and average workers, push companies to join the new social movement, »the movement of creating a new economy with a new set of rules and redefine the way people perceive success in the business world«. Hickman et al. (2014) have found that regions with higher educational attainment, which are politically progressive, have healthier populations, rank high in greenness, and are diverse, tend to have higher B-Corp adoptions, but higher per capita income, is on average, associated with lower rates of commitment. B Corp certificate attracts a growing segment of customers who value companies that behave in a socially responsible manner. The benefits from the recognizability of the certificate could be seen only in countries where this certificate has gained greater publicity. Additionally, B Corps benefit from increased media attention, which provides extra exposure of their brand and products to the public (Corbett and Katz, 2018; NBIS, 2012). B Lab also provides visibility through company profiles on its website. Since 2013 B Lab releases list honouring the top-performing Certified B Corps in each impact area and overall, an annual Best for the World list. The Best for the World Honouree information next to the company profile at the publicly available B Corp directory enables the Honourees to stand out among rapidly growing B Corp community. By being part of a B Corp community certified B corporations gain access to quality services and products from each other (at generous discounts) and from partners that provide specialized and/or discounted services to B corps. B Service Partners are divided into 7 categories: Financial, Sales and Marketing, Systems and Implementation, HR and Office Management, Educational, Consulting and Professional Services, and Products and Individual Opportunities (NBIS, 2012, p. 7). The B Corp certificate attracts socially responsible investors (SRI). In that way it offers to B Corps access to capital from investors who seek to generate social benefits next to the financial returns. B Corps can receive a free GIIRS rating to help attract investment capital from impact investors (NBIS, 2012, p. 7). Certificate also empowers management to make decisions in the interest of different stakeholders, not in a way as in legal entities such as SPC or Benefit Corporations, but it gives certainly more arguments to justify a stakeholder approach to management in their daily activities. This is an area where most controversial issues arise. The challenges in corporate governance related to the B Corp model and the potential legal problems are discussed in Clark and Babson (2012), Loewenstein (2013), Hasler (2014), Hemphill and Cullari (2014), McDonnell (2014), Plerhoples (2014), Strine (2014), Andre (2015), Neubauer (2016), Stecker (2016). B Corp certification indicates to unemployed or underemployed workforce that it is a company with strong commitment to positive working environment and employee engaging policies. The certificate attracts in that way quality employees who strive to live their values at work. By clearly declaring their focus towards positive social impact B Corporations can more easily attract individuals whose values will make a good fit with the organization's values. Several research papers have shown that millennials are searching for purpose-driven employers (e.g. Yuen and Rosen, 2013). The certificate gives socially conscious customers a less difficult way to differentiate impact-driven companies from »green washing« companies. It could be therefore used as a tool to increase consumer trust. By collaborating with B Corporations suppliers are encouraged to apply best practices in their environmental and social policies. The media can become leaders in promoting socially desirable (acceptable) way of doing business by reporting about the growing B Corp community and its benefits for society. They can also be a voice of many individuals (professionals and academics) and groups who reason the need for passing bills that will enable incorporation of new legal structures such as Benefit Corporation or SPC. By realising the benefits of the B Corp certificate and the new legal entities governments could shape an environment where hybrid organizations with socio-economic purpose could flourish.

The academic and non-academic papers discussing the benefits of B Corp certificate and new legal structures could encourage national governments to realize the critical role of the new legal framework in reducing negative externalities and in reducing costs to society which arise from them, i.e. to reduce costs of remedying the consequences of negative externalities. Local communities with a growing B Corp community, experience positive externalities (better land, safer working environments, healthier population ...), lower/less negative externalities or lower risk of negative externalities, and support in local development (through donations for local educational, sports, cultural or social projects). Regional economies with a strong B Corp community are building an image of socially conscience society who cares for its citizens of today and tomorrow.

## 5. THE RELEVANCE AND DISTRIBUTION OF CERTIFIED B CORPORATIONS IN THE EUROPEAN UNION

The European B Corp movement was officially launched in 2015 with 60 certified companies, although some companies have attained the certificate a few years earlier. Since then the number of certified B Corporations in the European Union has grown to 457. Its distribution across EU countries is given in Table 1.

*Table 1: The distribution of Certified B Corps across EU countries, 2015-2018 (Authors)*

Country	Number of certified B Corps	Certified before 2015	Certified since 2015	Certified since 2016	Certified since 2017	Certified since 2018
Austria	3	0	0	2	1	0
Belgium	7	1	1	1	0	4
Czech Republic	1	0	0	1	0	0
Denmark	6	0	0	1	2	3
Finland	1	0	0	0	1	0
France	57	1	16	12	16	12
Germany	26	2	8	5	6	5
Greece	1	0	0	0	1	0
Hungary	2	0	0	0	1	1
Ireland	1	0	0	0	0	1
Italy	73	6	2	31	24	10
Luxembourg	2	0	1	0	1	0
Malta	1	0	0	0	1	0
Netherlands	66	13	16	13	7	17
Poland	1	0	0	0	0	1
Portugal	9	1	2	3	1	2
Spain	35	2	5	11	8	9
Sweden	2	0	0	0	1	1
United Kingdom	163	6	41	36	36	44
<b>Total</b>	<b>457</b>	<b>32</b>	<b>92</b>	<b>116</b>	<b>107</b>	<b>110</b>

*Note: Bulgaria, Croatia, Cyprus, Estonia, Latvia, Lithuania, Romania, Slovakia, and Slovenia are currently countries with no certified B Corporations. The data are extracted from B Corp directory. Retrieved 03.11. 2018 from <https://bcorporation.net/directory>.*

The countries with the greatest share of certified B Corporations, as the data in Table 1 show, are United Kingdom, Italy, Netherlands, France, Spain and Germany. Passing the Società Benefit legislation in Italy has significantly contributed to the growth of certified B corporations. The Benefit Corporations gain additional value from attainment of B Corp certificate, especially in recognizability towards customers, but they also benefit from joining the B Corp community and its services. From the establishment of regional organization B Lab Europe, the number of certified B Corporations has significantly grown (from 60 to almost 500) and is still on the rise. The first certified companies (certified in Netherlands, France, Germany, Italy, and United Kingdom before 2015) were leaders and have paved the way for others. Most of companies identified in the research have attained the certificate since 2015 or later. The cross-sector analysis based on the data given in Table 2 shows that certified B Corps come from a very broad range of industry sectors (due to paper length limitation only the most represented sectors are given in the table): accounting services; agricultural services; apparel, footwear and accessories; architecture/design/planning; books and media; building materials; contractors and builders; credit provider; design/build; education and training services; electronics; employee benefits; energy efficiency and consulting; environmental remediation; equity investor – developed markets; equity investor – emerging markets; film and music production; fine arts; food and beverage; growers; housewares, home furnishings and accessories; healthcare consulting; healthcare provider; home and personal care; hospitality; HR consulting and recruiting; industrial manufacturing; insurance; investment advisor; IT software and services/Web design; legal services; machinery and equipment; management and financial consulting; marketing and communication services; non-profit consulting and fundraising; office products and printing; online community; online marketplace; pharmaceuticals and supplies; print publications; real estate development; recycling services and waste management; renewable energy generation and installation; rental services; restaurant; R&D; sports equipment, toys and accessories; storefront; sustainability consulting; travel and leisure; and other. However, some sectors are for now better represented in the European B Corp community, such as: consulting services (management and financial consulting, sustainability consulting), marketing and communication services, non-profit consulting and fundraising, education and training services, food and beverage, home and personal care, IT software and services/Web design, and renewable energy generation and installation. The first companies that were certified as a B Corp in an industry have made a mark and pushed others to follow their steps.

*Table following on the next page*

*Table 2: The distribution of Certified B Corps across industry sectors – mostly represented industries (Authors)*

Country	Education & training services	Food & beverage	Home & personal care	IT software & services/Web design	Marketing & communic. services	Manag. & financial consulting	Non-profit consulting & fund-raising	Sustain. consulting
Austria	0	0	1	0	0	0	0	0
Belgium	1	1	0	0	0	1	0	0
Czech Republic	0	0	0	0	0	0	0	0
Denmark	1	0	0	0	0	0	0	0
Finland	0	0	0	0	0	0	0	0
France	3	4	0	5	4	4	3	9
Germany	0	5	0	2	1	1	1	3
Greece	0	0	1	0	0	0	0	0
Hungary	0	0	0	0	0	0	1	0
Ireland	0	0	0	0	0	0	0	0
Italy	5	8	5	4	3	0	1	5
Luxembourg	0	0	0	0	0	1	0	0
Malta	0	0	0	0	0	1	0	0
Netherlands	1	3	2	2	3	13	0	4
Poland	0	0	0	0	0	0	0	0
Portugal	2	1	1	0	0	1	1	0
Spain	2	4	0	3	2	3	0	3
Sweden	0	0	1	0	0	0	0	0
United Kingdom	7	23	7	10	11	19	13	9
<b>Total</b>	<b>22</b>	<b>49</b>	<b>18</b>	<b>26</b>	<b>24</b>	<b>44</b>	<b>20</b>	<b>33</b>

The analysed data indicate that a growing trend in number of certified B Corporations could be expected in the near future in countries where certified B Corps already exist, and in countries which introduced the legislation for structures compatible with B Corp vision and purpose, such as the Società Benefit. Current practice from recent years shows that the best path to realize all the benefits from the B Corp movement is to parallelly promote the B Corp certificate and work for the passage and use of Benefit Corporations or other similar legal entities. With this strategy the growing number of certified B Corps in the forthcoming years could be also expected in countries with currently zero B Corps. The top-performing B Corps list includes 169 Best for the World Honourees from the EU. The countries with the biggest number of Honourees are United Kingdom (59), Netherlands (33), Italy (26), and France (22). They represent leaders in one impact area or in overall impact.

## 6. CONCLUSION

The B Corp certification dates to 2007 when a non-profit organization B Lab introduced the certificate in the USA. The development of B Corp certificate is related to the development of Benefit Corporation legal structure and from recently all certified B Corporations are required to adopt Benefit Corporation or Special Purpose Corporation-equivalent status in countries where such legislation was passed. The credibility of the certificate is assured through several verification mechanisms, background checks, in-depth site reviews, but also by independent committee' oversight, the regular updating of its rating and assessment systems, and its recertification requirements. More and more corporations are realizing the benefits of attaining the B Corp certificate such as: building consumer trust by distinguishing from »green washing« companies, attracting capital from impact investors, attracting best purpose-driven talents, empowering managers to make decisions in the interest of different stakeholders, and gaining access to B Corp community services.

Local economies and societies can expect a greater positive impact from a growing B Corp community at all levels (labour market, environment, costs reduction, projects ...). The establishment of regional organization B Lab Europe in 2015 was an impulse for a growing certification rate among EU companies. There are currently 457 certified B Corporations in the European Union, with the greatest number reported in United Kingdom, Italy, Netherlands, France, Spain and Germany. The introduction of the Società Benefit in Italy had a positive impact on the number of certified B Corporations. The European certified B Corporations come from a very broad range of industry sectors, however some sectors are for now better represented in the European B Corp community: consulting services (management and financial consulting, sustainability consulting), marketing and communication services, non-profit consulting and fundraising, food and beverage, home and personal care, IT software and services/Web design, and renewable energy generation and installation. Current practice from recent years shows that the best path to realize all the benefits from B Corp movement is to parallelly promote the B Corp certificate and work for the passage and use of Benefit Corporations or other similar legal entities. To address the challenges in corporate governance related to the B Corp model and the potential legal problems mentioned in the paper the authors' future work will require a comprehensive review of the case-law (the number of law cases regarding these issues should be greater in the forthcoming years). The B Corp certificate, as any other certificate, is not a perfect tool, and does not always guarantee the best possible behaviour, but it is despite its shortcomings in metrics as well as in the verification processes, a significant step towards socially conscious economy.

#### **LITERATURE:**

1. Alexander, F. H. (2017a). *Benefit Corporation Law and Governance: Pursuing Profit with Purpose*. San Francisco: Berret-Koehler Publishers, Inc.
2. Alexander, F. H. (2017b). *Next Phase for Benefit Corporation Governance Begins*. Thomson Reuters Expert Analysis. December 11, 2017.
3. Andre, R. (2015). *Benefit Corporations at a Crossroads: As Lawyers Weigh In, Companies Weight Their Options*, *Business Horizons*, Vol. 58, No. 3, pp. 243-252.
4. B Lab (2018a). *The Complete Guide to B Corp Certification for Small to Medium-Sized Enterprises*.
5. B Lab (2018b). *Inclusive Economy Challenge: 2018 Impact Report*.
6. Corbett, A. C., Katz, J. A., ed. (2018). *Hybrid Ventures. Advances in Entrepreneurship, Firm Emergence and Growth, Volume 19*. Bingley: Emerald Publishing.
7. Clark, W. H., Babson, E. K. (2012). *How Benefit Corporations Are Redefining the Purpose of Business Corporations*, *William Mitchel Law Review*, Vol. 38, No. 2, pp. 817 – 851.
8. Hasler, J. E. (2014). *Contracting For Good: How Benefit Corporations Empower Investors and Redefine Shareholder Value*, *Virginia Law Review*, Vol. 100, pp. 1279 – 1322.
9. Hemphill, T. A., Cullari, F. (2014). *The Benefit Corporation: Corporate Governance and the For-profit Social Entrepreneur*, *Business and Society Review*, Vol. 119, No. 4., pp. 519-536.
10. Hickman, L. et al. (2014). *Explaining the Location of Mission-Driven Businesses*, *Journal of Corporate Citizenship*, No. 55, pp. 13-25.
11. Honeyman, R. (2014). *The B Corp Handbook: How to Use Business as a Force for Good*. First edition. San Francisco: Berret-Koehler Publishers, Inc.
12. Kim, S. et al. (2016). *Why Companies Are Becoming B Corporations*, *Harvard Business Review*, June 17, 2016. Retrieved 08.11.2018 from <https://hbr.org/2016/06/why-companies-are-becoming-b-corporations>.
13. Loewenstein, M. (2013). *Benefit Corporations: A Challenge in Corporate Governance*, *The Business Lawyer*, Vol. 68, pp. 1007-1038.

14. McDonell, B. H. (2014). Committing To Doing Good and Doing Well: Fiduciary Duty in Benefit Corporations. *Fordham Journal of Corporate & Financial Law*, Vol. 20, pp. 19 -72.
15. NBIS (2012). B Corporations, Benefit Corporations and Social Purpose Corporations: Launching a New Era of Impact-Driven Companies. Retrieved 06.11.2008 from [http://nbis.org/wp-content/uploads/2012/10/ImpactDrivenCompanies\\_NBIS\\_Whitepaper\\_Oct2012.pdf](http://nbis.org/wp-content/uploads/2012/10/ImpactDrivenCompanies_NBIS_Whitepaper_Oct2012.pdf)
16. Neubauer, K. A. (2016). Benefit Corporations: Providing A New Shield for Corporations with Ideals Beyond Profits. *Journal of Business & Technology Law*, Vol. 11, No. 1, pp. 109 - 129.
17. Olsen, S., Galimidi, B. (2008). Catalog of Approaches to Impact Measurement: Assessing Social Impact in Private Ventures. Retrieved 06.11.2018 from [http://www.midot.org.il/Sites/midot/content/File/CATALOG%20OF%20APPROACHES%20TO%20IMPACT%20MEASUREMENT\(1\).pdf](http://www.midot.org.il/Sites/midot/content/File/CATALOG%20OF%20APPROACHES%20TO%20IMPACT%20MEASUREMENT(1).pdf).
18. Pelatan, A., Randazzo, R. (2016). The First European Benefit Corporation: Blurring the Lines Between »Social« and »Business«. Retrieved 06.11.2018 from <https://www.bwblp.com/file/benefit-corporation-article-june-16-pdf>.
19. Plerhoples, A. E. (2014). Delaware Public Benefit Corporations 90 Days Out: Who's Opting In?, *UC Davis Business Law Journal*, Vol. 14., pp. 246 – 280.
20. Rawhouser, H. et al. (2015). Benefit Corporation Legislation and the Emergence of a Social Hybrid Category. *California Management Review*, Vol. 57, No. 3., pp. 13 -35.
21. Roth, F. M. S., Winkler, I. (2018). *B Corp Entrepreneurs: Analysing the Motivations and Values Behind Running a Social Business*, Palgrave-Macmillan.
22. Sabeti, H. (2009). *The Emerging Fourth Sector: A New Sector of Organizations at the Intersection of the Public, Private, and Social Sectors*, Executive Summary, The Aspen Institute. Retrieved 06.11.2018 from <https://assets.aspeninstitute.org/content/uploads/files/content/docs/pubs/4th%20sector%20paper%20-%20exec%20summary%20FINAL.pdf>.
23. Scuri, M. (2017). *Certified B Corps in Italy: Organization, Motivations and Change After the Certification*, Master Thesis, Università Commerciale Luigi Bocconi. Retrieved 08.11.2018 from <http://www.societabenefit.net/wp-content/uploads/2017/05/Certified-B-Corps-in-Italy.pdf>.
24. Stecker, M. J. (2016). Awash in a Sea of Confusion: Benefit Corporations, Social Enterprise, and the Fear of »Greenwashing«, *Journal of Economic Issues*, Vol. 50, No. 2, pp. 373 – 381.
25. Strine, L. E. (2014), Making It Easier for Directors to »Do the Right Thing«? *Harvard Business Law Review*, Vol. 4., pp. 235 – 253.
26. Yuen, J., Rosen, R. (2013). Why Be a B Corp? Ask a Millennial, Retrieved 10.11.2018 from [https://www.sustainablebrands.com/news\\_and\\_views/communications/why-be-b-corp-ask-millennial](https://www.sustainablebrands.com/news_and_views/communications/why-be-b-corp-ask-millennial).
27. Wilburn, K., Wilburn, R. (2015). Evaluating CSR Accomplishments of Founding Certified B Corps, *Journal of Global Responsibility*, Vol. 6, No. 2, pp. 262-280.

# THE IMPACT OF SHAREHOLDER PERCEPTION OF CAPITAL ON OWNERSHIP STRUCTURE IN THE CONTEXT OF SHAREHOLDER DEMOCRACY - CASE OF THE CROATIAN CAPITAL MARKET

**Ante Samodol**

*Libertas International University, Croatia  
asamodol@libertas.hr*

**Sonja Brlecic Valcic**

*Libertas International University, Croatia  
sbrlecic@libertas.hr*

## **ABSTRACT**

*The problem of share ownership structure in the Republic of Croatia is closely connected to the development of the financial market itself, as well as to the privatisation of companies that were state-owned in the previous economic regime. In general, we can say that higher limitations related to the range of privatisation in terms of income and shares sold appear in countries with inefficient legislation, where shareholders are less protected, banks are strong and capital markets less developed. Therefore, in the development typology context within the frame of mapping out institutional cooperation and changes necessary for development, it is necessary to observe the Croatian capital market in relation to the chronological development stage of capital market and shareholding, volume of shareholders, shareholder structure and volume as well as value of shares. This paper provides an analysis of data on share ownership structure in relation to the nominal and market value of shares traded on the Croatian capital market from 2006 to 2018. Analyses conducted through SOM and ANFIS indicate that the essence of the problem of share ownership/ value structure is the concentration of legal entities and that the share in the structure of legal entities affects nominal value, while the market value can be connected to the share of natural persons and others. Shareholder democracy in the Croatian capital market has given way to the concentration of ownership with the tendency of over-the-counter and non-transparent increase in ownership, while a strong corporate control of few is replacing corporate democracy and the corporate management code. These circumstances of ownership transformation are encouraging social exclusion and enhancing the impact of connected ownership and interest groups (crony capitalism) instead of developing a modern shareholder democracy, as well as social and market inclusion.*

**Keywords:** *shareholder perception of capital, ownership structure, shareholder democracy*

## **1. INTRODUCTION**

The discussion on shareholder democracy is one founded on optimal mixture of aggregate and entity processes of decision making. It is a discussion that weighs the perception of value between coordination costs of an aggregate approach and agency costs of entity approach (Holderness, 2003). On the whole, modern analysis concepts of relationships between finances and democracy are reflected in the analysis of different dimensions (Walby, 2013, pp 489–507), of which it is important to mention the conceptualisation of finances, relationship between finances and the economy, relationship between finances and the government, relationship between finances and the society and the nature of the social system. The analysis of these financial frameworks in a society determines the framework for the analysis of finances and democracy as foundation for a legal regulation, to which the problem of observing shareholder democracy is indirectly tied. Within the most frequently accepted theory of capitalist system, the systems of corporate management of public companies are theoretically and legally conceptualised in such a way that managers need to serve the shareholders' interests to a certain

extent. Therefore, the economic approach to corporate management can lead to two different meanings of its definition (Rebérioux, 2002, pp 111–134). The first is the agency one, according to which shareholders and managers have a privileged relationship that is focused on the methods and purposes of maximising the shareholders' returns on investments. Such an approach to corporate management promotes shareholder value as a natural method of managing a corporation. In the other, wider meaning, ownership still represents the prevailing factor of the definition, and ownership rights are a crucial component of shareholding. Based on data from 2006 to 2018, this paper researches into the structure of share ownership and the connection of the structure with shareholders' perception on the capitalization of a company, i.e. the amount of share capital within the context of shareholder democracy. From an economic aspect, the observed relationships depend on the privatisation process, which has been in effect in this area since the switch to a market-oriented economic system, and from a legal aspect, on the legislation related to regulations determining the capital market and the ones determining shareholders' participation and impact level in the general assembly within the Corporations Act. Thusly determined issue relates to previous research that state that the level of connection of specific ownership and control structures, together with the level of profit opportunities, depends on the specific economic circumstances. These circumstances primarily include the quality of the banking system, legal and judicial protection of shareholders and the required level of financial liability (Claessens, Djankov, Fan, & Lang, 2002, pp 2741–2771).

## **2. THEORETICAL BACKGROUND**

The problem of ownership structure in the Republic of Croatia is closely connected to the development of the financial market itself in the country, as well as to the privatisation of companies that were state-owned in the previous economic system. The development of financial market in the area, which still has not achieved a satisfying and necessary level for a regular economic development, can be connected to the capital centralisation phenomenon. Namely, although empirical research has not confirmed the existence of a global tendency toward capital centralisation orientation nor the existence of possible connections between the economic crisis and capital centralisation, the dynamics trend of the phenomenon has assumed a more regular and a more general character since the beginning of the financial crisis in 2007 (Brancaccio, Giammetti, Lopreite, & Puliga, 2018, pp 94–104). On the other hand, the range of privatisation in terms of income and shares sold appears with higher limitations in countries with inefficient legislation, in which shareholders are less protected, banks are strong and capital markets less developed (Bortolotti, Fantini, & Siniscalco, 2004, pp 305–332). Today, the effectiveness of restructuring, which should follow after most acquisitions, is increasingly prevalent in economies once dominated by stable ownership structures and more corporate ways of acquiring. These phenomena are constituents of the so-called marketization of corporate control, i.e. the process through which market mechanisms spread to the area of corporate control and corporate acquisitions. Most literature dealing with the marketization of corporate control requires the approach of separation of varieties of capitalism (VoC), which developed typologies for the characterisation of institutional cooperation of different national capitalist systems (Maisenbacher, 2018). These typologies indicate that corporations are literally being transformed into commodities, i.e. mechanisms for keeping, selling and buying corporate shares, and consequently, a way of generating and maximising profit. VoC approaches are often so directed toward socioeconomic institutional configurations that they are similar to the dominant systems of corporate management that map out institutional changes. National systems of corporate management are oriented toward the idealised American model of shareholder activism and liquid share market. Such an approach ideologically supports shareholding, which consists of three components: prudential, functional and moral (Engelen, 2002, pp 391–413).



The prudential requires superior efficiency in shareholder control and market distribution of capital; the functional is based on the demand for shareholder control related to risk capital contribution, while the essence of the moral is the liberal doctrine of ownership founded on exclusive rights of securities' supervision. Modern concepts (Engelen, 2002) suggest corporate democracy as a way of consolidating the interest of all stakeholders in the mentioned concepts, the assumptions for which require an intelligent democratic distribution. In developed markets there is an evident relationship among market liquidity, ownership structure and public information production, whether it is information coming from major blockholders or public information projected by financial analysts (Staglianò, La Rocca, & Gerace, 2018, pp 203–214). The intensity of analytical information impact on market liquidity changes in relation to the levels of ownership concentration. In the context of the above mentioned it is necessary to contemplate the typology of the Croatian capital market development within the framework of mapping out institutional cooperation and changes needed for development. The previously described process can thus be analysed through several key features:

- chronological stage of capital market and shareholding development
- volume of shareholders
- shareholder structure and
- movement of the number and the value of shares.

The landmark years in the volume of shareholders were 2002 and 2008. The so-called compulsory listing of public companies that brought the majority of shareholders on the stock market began in the third trimester of 2002 and was in effect until the end of 2008. The increased volume of shareholders on the stock market, recorded by the Central Depository & Clearing Company Inc. (CDCC), enabled larger trading volumes and changes in ownership structures. However, since the beginning of crisis in 2009 there has been not only a decrease in the trading volume, but also a procedure of delisting and exiting the Zagreb Stock Exchange (ZSE), whereby a significant number of shareholders dropped. The observance of the movements in ownership structure in the period from 2006 to 2018 indicates a mirrored alternate change in ownership between domestic natural persons and others on the one hand, and domestic legal entities and foreign persons on the other. However, in the period after the onset of the financial crisis in 2009 to 2018 there was a continued relinquishment of shares owned by foreign persons and acquisition of shares by domestic legal entities. It is noteworthy that the domestic legal entities are companies (joint-stock, limited liability), and that in the Central Depository and Clearing Company's (CDCC) records there is no difference in the SPEs and the "regular" companies, the primary business activity of which is not investing in securities. This category also includes financial institutions (banks) as well as the public sector (government, municipalities and local self-government, agencies and others). Foreign persons include foreign natural persons (foreign passport) and foreign (non) legal entities registered in another country. The others are mostly portfolio investors, not exclusively, but mostly. This category also comprises investors that cannot be otherwise classified. Likewise, it is easily noticeable that the owners of equity observed through nominal value of shares did not deal with the strengthening of the capital base of the issuer of shares, so the entire period from 2006 to 2018 saw an increase in nominal value from (1EUR=7,5136 at 31 December 2017) HRK 121 bn to HRK 133 bn (10%), whereas the market value increased from HRK 154 bn to HRK 295 bn (acknowledging the method of recording market value). Nevertheless, in relation to the above mentioned we consider that it is sensible to show the market value of listed shares in the same way in which the value is shown in the ZSE trading statistics. For example, at the end of Q1/2018 the market value of all shares, according to the CDCC's records, was HRK 298bn, while the market value of all shares listed in the ZSE was HRK 115bn. The difference in the market value of the total shares recorded in CDCC and the shares listed in ZSE can be additionally clarified with

consideration to the fact that only 15% of issued shares recorded by the CDCC was listed in the ZSE in 2018, i.e. only 40% (HRK 115 bn) was the result of supply and demand from the current stock market quotation, while 60% (the remaining value totalling 298 bn) was the result of historical valuations.

### 3. METHODOLOGY AND DATA SET

Within the determined problem of research on the data set shown in Table 1 (Appendix), we analysed the relationship of ownership structure and nominal and market value of shares. The ownership structure is expressed in percentages, while the nominal and market value were normalised with the purpose of easier utilisation of analysis tools. Due to the specific topology that allows the hidden layer to form the visualization of the distribution and the two-dimensional approximation of the topology of the input set of vectors (Brlčić Valčić, 2016, pp 241-256), we began the analysis with the Kohonen's Self-Organizing Maps (SOM), (Kohonen, 2001). In the hidden self-organizing layer, a vector  $\mathbf{n}_{m \times 1}^1$  is formed first of which the coordinates of form  $n_i^1 = -\|\mathbf{IW}_{1 \times n}^i - \mathbf{p}_{n \times 1}\|$  represent the negative (ndist) Euclidean distance between the represented vector  $\mathbf{p}_{n \times 1}$  and vector  $\mathbf{IW}_{1 \times n}^i$  representing  $i$  row of weight coefficient matrices  $\mathbf{IW}_{m \times n}$ .

(1)

The 2D topology of the network is self-organized through 200 iterations with 20 neurons in the hidden layer. Table 2 shows the names of variables that will be shown as SOM analysis results.

*Table 2: Names of variables for SOM analysis*

Parameter	Names of variables for SOM analysis
Domestic natural persons (%)	Weights from Input 1
Domestic legal entities (%)	Weights from Input 2
Foreign persons (%)	Weights from Input 3
Others (%)	Weights from Input 4
Nominal value of shares	Weights from Input 5
Market value of shares	Weights from Input 6

*Source: prepared by authors*

Afterwards, the same data set is analysed through the Adaptive Neuro-Fuzzy Inference System (ANFIS), which, as a universal approximator, offers a range of applications such as modelling nonlinear functions of multiple variables, identifying nonlinear components of on-line control systems, prediction of chaotic time series, etc. (Jang 1993, pp 665–685). Using an input-output dataset, ANFIS delivers a Fuzzy Inference System (FIS), whereby the membership functions parameters are adapted by a backpropagation learning algorithm or combined with the method of least squares (hybrid learning method). Such a setup allows the FIS system to learn from training data (Sugeno 1985). Table 3 shows the names of variables that will be shown as ANFIS analysis results.

*Table 3: Names of variables for ANFIS analysis*

Parameter	Names of variables for ANFIS analysis
Domestic natural persons (%)	Input 1
Domestic legal entities (%)	Input 2
Foreign persons (%)	Input 3
Others (%)	Input 4
Nominal value of shares	Output 1
Market value of shares	Output 2

*Source: prepared by authors*

For an easier image of ANFIS architecture, it is possible to assume that for some two input parameters  $x$  and  $y$ , and one output parameter  $f$ , with two fuzzy rules, it can be expressed as (Jang 1993):

Rule 1: IF  $x$  is  $A_1$  and  $y$  is  $B_1$  THEN  $f_1 = p_1x + q_1y + r_1$

Rule 2: IF  $x$  is  $A_2$  and  $y$  is  $B_2$  THEN  $f_2 = p_2x + q_2y + r_2$

where  $x$  and  $y$  are inputs,  $A_i$  and  $B_i$  are fuzzy sets,  $f_i$  is linear function of inputs,  $p_i$ ,  $q_i$  and  $r_i$  are parameters that are adjusted during the training phase, as presented in Figure 1 below.

Figure 1: ANFIS architecture

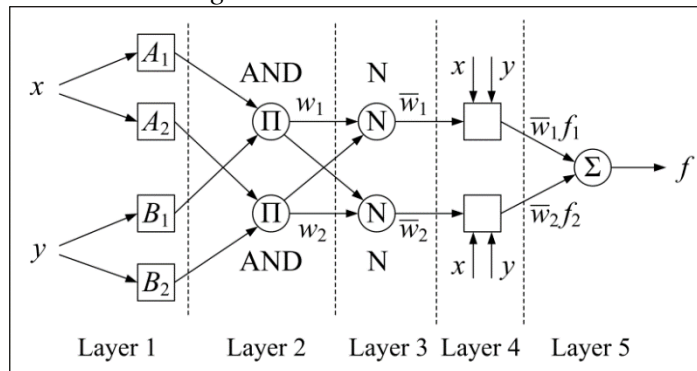

Source: Valčić et al. 2011

Finally, ANFIS output is calculated using the resulting parameters. The residuals between the calculated ANFIS output values and the actual outputs are used to adjust the assumed parameters for the next epoch on the basis of the standard learning algorithm with error backpropagation (Valčić et al. 2011, pp 373–382).

#### 4. RESULTS

The first analysis (SOM) indicates that the key issue is in the problem of ownership structure/nominal and market value for domestic legal entities, as shown in Figure 2.

Figure 2: SOM analysis

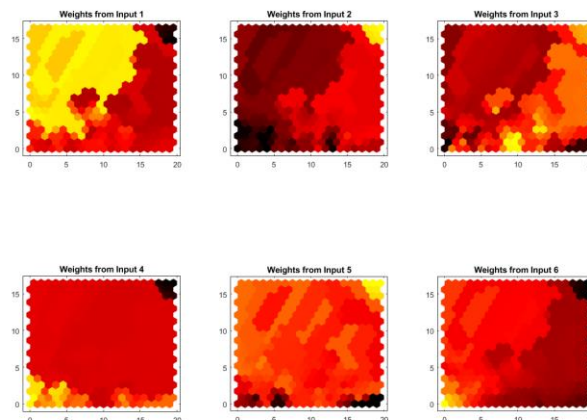

Source: prepared by authors

Likewise, we can conclude that the share in the structure of domestic legal entities has an impact on the nominal value, while the market value can be tied to the share of domestic natural persons and others. The analysis results for the impact of ownership structure on nominal and market value through ANFIS are shown in Figure 3.

Figure 3: Impact of ownership structure on nominal and market value

*Impact of ownership structure on nominal value*

*Impact of ownership structure on market value*

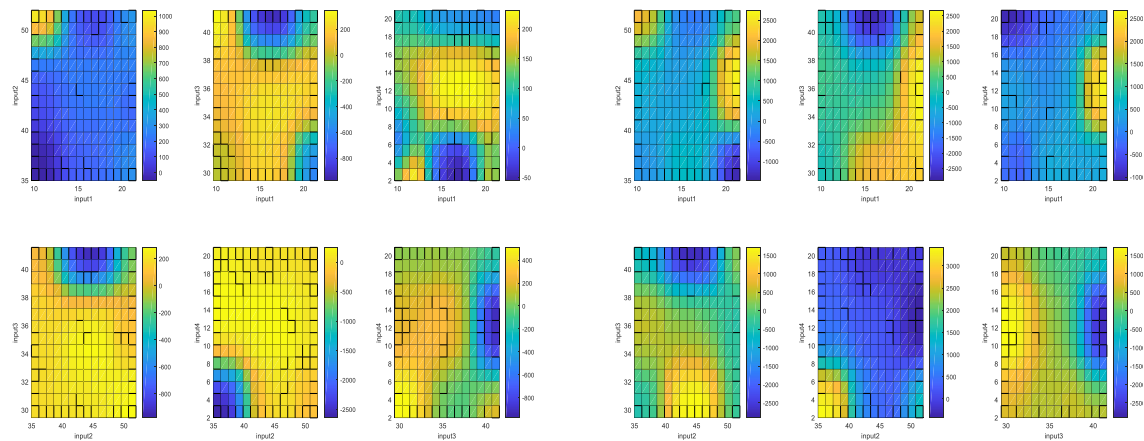

Source: prepared by authors

A more detailed analysis of the impact of ownership structure on nominal value (ANFIS) brings the conclusion that:

- the combination of domestic natural persons and domestic legal entities has the highest positive impact on nominal value, and any relationship of these two categories cannot adversely affect nominal value, whereas high positive impact can be achieved by a smaller share of domestic natural persons (10 – 13%) and a larger share of domestic legal entities (47 – 55%);
- all other combinations can have a negative impact on nominal value;
- the relationship of domestic natural and foreign persons can cause moderate positive impact (up to value 200) in combination with the share of domestic legal entities of 13 – 17% and foreign entities 30 – 60% or domestic legal entities of 10 – 12% and foreign over 40%. The possibility of negative impact is evident in the combination of domestic natural persons 12 – 18% and foreign persons 39 – 43%;
- if we observe the relationship of domestic natural persons and others, a moderate positive impact can be effected by the structure of domestic natural persons 12 – 20% and others 10 – 16%, whereas the possibility of mild negative impact occurs in the share of domestic natural persons of 15 – 18% and others of 2 – 7%;
- -the relationship of domestic legal entities and foreign legal entities mostly indicates mildly and moderately positive impact on nominal value, but the analysis of these relationships also shows the possibility of greater negative impact for the combination of domestic legal entities of 40 – 50% and foreign legal entities over 38%;
- the relationship of domestic legal entities and others does not indicate any positive impact on nominal value, but a share of domestic legal entities in the structure of 35 – 40% and others of 2 – 8 % might cause an extremely high negative impact.

- the analysis of the relationship of foreign persons and others indicates the possibility of positive impact with a concentration of foreign persons from 30 to 33% and others from 2 to 8 %.

On the other hand, the analysis of the impact of ownership structure on market value leads to a conclusion that:

- over 20% share of domestic natural persons combined with 40 – 50% share of domestic legal entities can have a positive impact on a dramatic increase in market value. Likewise, over 20% share of domestic natural persons combined with a lower concentration of domestic legal entities of 35 – 40% can have a strong negative impact on market value;
- 13 – 20% share of domestic natural persons combined with 30 – 40% share of foreign persons can also have a strong impact on the increase in market value, while a concentration of 12 – 18% of domestic natural persons combined with 30 – 40% share of foreign persons can cause strong negative impact on market value;
- 18 – 22 % share of domestic natural persons combined with 8 – 16% share of others can have a strong impact on the increase of market value, while a combination of 10% share of domestic natural persons and 18 – 20% share of others can cause negative impact on market value;
- 40 – 47% share of domestic legal entities combined with 30 – 35% share of foreign persons can cause a strong positive impact on the increase in market value, whereas negative effects can occur in a concentration of 40 – 50% of domestic legal entities and 40 – 42% of foreign persons;
- 35 – 40% share of domestic legal entities combined with 2 – 6% share of others indicate a possibility of a high increase in market value, while all other combinations of this relationship indicate a mild, but positive impact on market value;
- 30 – 40% share of foreign persons combined with 2 – 20% share of others can also cause strong positive impact on market value, whereas a strong negative impact can be felt in the combination of 40% share of foreign persons and 8 – 19% share of others.

## 5. CONCLUSION

Shareholders' perception of capital on the Croatian market can be observed through:

- a) the chronological stage of capital market and shareholding development
- b) volume of shareholders
- c) shareholder structure and
- d) volume and value of shares

Having that in mind, the following facts:

- a) 60% of ownership of all issued shares from CDCC records is held by domestic owners, most of whom are legal entities (43%),
- b) only one-third belongs to foreign persons (34%),
- c) only 40% of shares (2018) from the CDCC records is valued in accordance to the supply and demand on the ZSE,
- d) total number of shares listed on the ZSE dropped from 383 (2007) to 116 (2018) or by 70%,
- e) the percentage of active shareholders in the total number of shareholders is less than 2%, lead to a conclusion that the shareholder democracy has given way to ownership concentration (especially due to undetermined connections within ownership structure of domestic legal entities as shareholders) and the over-the-counter, non-transparent ownership has the tendency to increase, while a strong corporate control of few has been replacing corporate democracy and corporate management code. These circumstances of ownership transformation are enhancing social exclusion of others and the impact of

connected ownership and interest groups (crony capitalism) instead of developing a modern shareholder democracy, social and market inclusion.

The results of analyses conducted in this research suggest that a concentration of domestic legal entities of over 40%, foreign of about 30%, domestic natural persons of over 20% and others of 10% could have a significant role in the increase in nominal value of shares. Likewise, the possibility of a strong negative impact on nominal value is indicated by the concentration of domestic natural persons of 20%, domestic legal entities of 40%, foreign persons of over 45% and others of 15%, i.e. the share of others should decrease and the shares of domestic natural persons and legal entities should increase. A positive impact on market value is visible when there is an increase in the concentration of domestic natural persons of over 20% and 35 – 40% share of domestic legal entities, while the influence of others on market value is mostly related to creating negative impact in concentrations of 8 – 18% (and if it is observed with a combination of domestic natural persons, this percentage can go up to 20%). The recommendations for further research would be to analyse ownership structure and the volume and value of shares in relation to the increase or decrease in GDP.

#### **LITERATURE:**

1. Bortolotti, B., Fantini, M., Siniscalco, D. (2004). Privatisation around the world: Evidence from panel data. *Journal of Public Economics*, 88(1–2), pp 305–332.
2. Brancaccio, E., Giammetti, R., Loprete, M., Puliga, M. (2018). Centralization of capital and financial crisis: A global network analysis of corporate control. *Structural Change and Economic Dynamics*, 45, pp 94–104.
3. Brlečić Valčić, S. (2016). Relationship between different business value components within the oil and gas industry. *Ekonomski vjesnik : časopis Ekonomskog fakulteta u Osijeku*. Vol. 29. Issue 1. pp 241-256.
4. Claessens, S., Djankov, S., Fan, J. P. H., Lang, L. H. P. (2002). Disentangling the Incentive and Entrenchment Effects of Large Shareholdings. *The Journal of Finance*, 57(6), pp 2741–2771.
5. Engelen, E. (2002). Corporate governance, property and democracy: A conceptual critique of shareholder ideology. *Economy and Society*, 31(3), pp 391–413.
6. Holderness, C. G. (2003). Joint ownership and alienability. *International Review of Law and Economics*, 23(1), pp 75–100.
7. Jang JSR (1993) ANFIS: Adaptive-Network-based Fuzzy Inference Systems. *IEEE Transactions on Systems, Man, and Cybernetics* 23(3): pp 665–685.
8. Kohonen, T., 2001. *Self-Organizing Maps*, 3rd ed. Springer, Berlin.
9. Maisenbacher, J. (2018). Transnational capital unbound? A critical institutionalist perspective on the marketization of corporate control in Serbia and Turkey. *Competition and Change*.
10. Reberioux, A. (2002). European style of corporate governance at the crossroads: The role of worker involvement. *Journal of Common Market Studies*, 40(1), pp 111–134.
11. Staglianò, R., La Rocca, M., & Gerace, D. (2018). The impact of ownership concentration and analyst coverage on market liquidity: Comparative evidence from an auction and a specialist market. *Economic Modelling*, 70(March 2016), pp 203–214.
12. Sugeno M (1985) *Industrial Applications of Fuzzy Control*. Elsevier Science, Inc. New York, NY, USA
13. Valčić M, AntoniĆ R, Tomas V (2011) ANFIS Based Model for Ship Speed Prediction. *Brodogradnja* 62 (4), pp 373–382.
14. Walby, S. (2013). Finance versus democracy? Theorizing finance in society. *Work, Employment and Society*, 27(3), pp 489–507.

**APPENDIX**

*Table 1: Dataset*

Date	Domestic natural persons %	Domestic legal entities %	Foreign persons %	others%	Nominal value of shares (in bil. of kn)	Market value of shares (in bil. of kn)
March 31 2006	11,66	46,05	30,7	11,58	120,8	197,02
June 30 2006	11	44,18	33,16	11,66	121,2	208,68
September 30 2006	10,98	42,54	34,57	11,9	122,3	237,71
December 31 2006	10,85	41,59	37,72	9,83	123,1	258,82
March 31 2007	10,91	38,7	38,33	12,05	123,7	331,61
June 30 2007	11,6	37,74	38,48	12,19	127,8	374,59
September 30 2007	11,98	37,66	29,44	20,92	128,7	379,57
December 31 2007	13,76	35,62	30,08	20,54	128,7	407,7
March 31 2008	13,64	35,66	31,66	19,04	131,8	339,13
June 30 2008	14,06	35,23	31,93	18,78	134	311,72
September 30 2008	13,65	34,96	33,34	18,05	134,2	281,7
December 31 2008.	12,68	36,89	36,23	14,21	133,3	211,28
March 31 2009	12,69	36,16	38,24	12,91	134,4	195,44
June 30 2009	12,76	36,13	35,7	15,41	134,7	211,5
September 30 2009	12,84	38,92	35,96	12,27	133,9	228,85
December 31 2009	12,69	43,86	41,46	1,98	133,8	224,22
March 31 2010	13,91	43,09	40,91	2,09	134,2	231,46
June 30 2010	12,96	43,71	41,29	2,04	134,4	216,63
September 30 2010.	13,17	43,18	41,55	2,11	134,3	221,9
December 31 2010	12,21	45,27	39,7	2,82	134,4	239,97
March 31 2011	11,92	48,39	36,65	3,05	132,7	247,05
June 30 2011	11,62	49,07	36,26	3,05	132,4	243,51
September 30 2011	11,23	49,88	35,8	3,1	136,9	228,97
December 31 2011	11,23	49,42	36,27	3,07	136,4	219,51
March 31 2012	11,1	49,2	36,7	3	136,3	221,24
June 30 2012	10,88	50,18	35,9	3,03	136,2	215,2
September 30 2012	10,56	51,96	34,24	3,24	135,7	222,04
December 31 2012	10,08	47,54	39,31	3,07	134,1	234,65
March 31 2013	10,34	48,05	38,37	3,24	134,6	246,47
June 30 2013	10,05	49,44	37,28	3,22	134,6	238,86
September 30 2013	9,88	50,09	36,76	3,27	134	235,42
December 31 2013	9,86	48,96	38,02	3,16	134,2	230,55
March 31 2014	9,92	48,82	38,13	3,13	132,4	227,76
June 30 2014	9,68	49,84	37,44	3,04	132,3	237,26
September 30 2014	15,3	48,18	33,5	3,02	134,6	257,93
December 31 2014	20,97	43,1	33,19	2,74	133,9	271,02
March 31 2015	20,84	42,91	33,5	2,75	134,7	275
June 30 2015	20,76	42,65	33,84	2,76	137,2	278,75
September 30 2015	20,89	42,76	33,42	2,93	138,4	275,11
December 31 2015	21,34	41,73	33,76	3,17	137,5	274,55
March 31 2016	21,57	40,68	34,52	3,23	137,8	269,85

36th International Scientific Conference on Economic and Social Development –  
"Building Resilient Society" - Zagreb, 14-15 December 2018

---

June 30 2016	21,19	41,02	34,33	3,46	136,9	271,79
September 30 2016	20,79	40,81	34,65	3,75	135,3	289,54
December 31 2016	20,88	39,96	35,18	3,97	134,4	292,7
March 31 2017	20,94	38,82	36,41	3,83	134,8	292,58
June 30 2017	19,84	43,67	32,66	3,83	137,8	303,75
September 30 2017	19,65	43,5	33,1	3,75	137,5	302,69
December 31 2017	19,71	42,87	33,68	3,74	136,5	299,13
March 31 2018	19,65	42,79	33,87	3,69	133,5	298,3



# THE CHARACTERISTICS OF MERGERS AND ACQUISITIONS AND THEIR IMPACT ON PERFORMANCE IN EMERGING COUNTRIES: A SAUDI ARABIAN STUDY

**Sara Khotbi**

*University of Aix-Marseille,*

*IAE Aix-Marseille Graduate School of Management, Aix-en-provence, France*

*Sara.khotbi@iae-aix.com*

## **ABSTRACT**

*Mergers and acquisitions are attracting interest from financial researchers who are trying to determine the performance of these high-risk operations. It is not easy to identify variables that precisely map into the various factors that affect value creation through cross border mergers and acquisitions nor to pick an appropriate performance indicator because the definitions of performance vary in terms of accounting, financial and operational views. In this paper, we focused on the impact of the characteristics of the transaction on the corporate financial performance of mergers and acquisitions, which are return on investment, return on equity and Marris ratio, using data on the deals that occurred during the period 2010-2015 in Saudi Arabia. Panel data and precisely random effect method are applied to carry out empirical analysis. In this paper, we examine whether specific merger characteristics impact the M&A's performance. The results show that the performance is negatively influenced by the level of indebtedness for the 3 performance indicators and by the sectorial proximity for the return on equity. The cash level has a very slight positive impact on the 3 indicators. Concerning the other explanatory factors, they do not have a significant effect on performance for the acquiring firms.*

**Keywords:** *Emerging economies, mergers and acquisitions, operation characteristics, performance measures*

## **1. INTRODUCTION**

In the era of globalization of industry and markets, which is characterized by increasingly greater competition, businesses now operate in an increasingly competitive environment with market shares tending to narrow and unpredictable and frequent changes, seek to protect themselves against the main risk, that of their disappearance. To do so, companies are forced to circumvent this phenomenon through a regrouping movement. The use of strategic alliances, mergers or the purchase of local companies now enables them to solve problems more easily, such as the acquisition of new markets, the establishment of a distribution network, the training of the employees, improving their profit margins or intangible objectives such as improving their technological or organizational knowledge. The main objective of these operations is to increase the results through the implementation of synergies (Ansoff, 1965) which are supposed to guarantee their success. Numerous studies have shown that the success of these operations was far from what was expected, and that not all of them allowed to increase performance and the latter remained uncertain. The risk of failure of such operations is high: the rate of failure announced varies between 45 and 70% (Cartwright & Cooper, 1993a, Ravenscraft & Scherer, 1987, Schoenberg, 2006). For our research, we focused on the impact of the characteristics of the transaction on the performance of mergers acquisitions. Our study focuses on the analysis of a sample of 83 Mergers and Acquisitions carried out in Saudi Arabia during the period from 2010 to 2015. To our knowledge, it is the first to examine specifically the relationship between transaction characteristics and the performance of the acquirers of Saudi Arabian firms. We adopt a multivariate analysis framework to examine the relationship between the characteristics of takeovers, the acquiring firm and operational performance during the post-acquisition period.

We study successively: the impact of cash level, debt level, cross-border character and sectorial proximity on the post-acquisition performance of acquiring companies. Although numerous studies analyze mergers and acquisition in developed economies, a much smaller number of studies focus on M&As in of emerging economies. Our research question can now be clearly formulated: Do the characteristics of the M&A operation impact positively its performance? In order to answer this question, we have in the first part of this research paper a literature review on the various dimensions of mergers and acquisitions, namely the motivations behind the use of this kind of operations, the characteristics of the transaction affecting its operational performance as sectorial proximity, cross-border character, cash level and debt level and finally we will present the main measures and indicators of performane of mergers and acquisitions. In the second part of our research paper, we present the hypothesis we will be demonstrating through this paper. Then, we present our methodological choices (data collection, choice of dependent and independent variables as well as the formulation of the general model on which we will base our empirical analysis). In the last part, we will report the results of our empirical analysis while explaining the specific methods used for the data analysis then the we will discuss the results obtained.

## **2. LITTERATURE REVIEW**

### **2.1. Reasons behind mergers and acquisitions**

Mergers and acquisitions derive their justifications from multiple motivations. Management goals and objectives have been of central interest in research on mergers and acquisitions (M&A) for decades (Reiud, 1968; Steiner, 1975; Jensen and Ruback, 1983; see also Simon, 1964). The firm is described within the framework of the agency theory as a node of contract between several actors with divergent interests (Coase, 1937). Leaders and shareholders, like other actors, are opportunistic individuals who seek to maximize their respective well-being often to the detriment of each other (Jensen and Meckling, 1976). According to the theory of efficiency, the effects of synergies are the main objectives of mergers and acquisitions. These synergies can be achieved at several levels: financial, managerial and operational. For financial synergies, they result from the lower cost of capital. Weston and Chung (1983) argue that the increase in debt capacity following the M&As allows the new firm to reduce its cost of capital on one hand. On the other hand, the increase in the size of the company gives it better visibility, more credibility with the markets and therefore cheaper financing compared to small businesses. Managerial synergies are mainly linked to the interest of the leaders. The interests of leaders can manifest themselves in several forms, such as empire building strategies (Marris, 1963) and a diversification strategy to protect their human capital (Amihud and Lev, 1981). To this end, Jensen (1986) argues that the abundance of free cash flow available to managers leads to overpaying acquisitions. In terms of operational synergies, they derive mainly from economies of scale and economies of scope. By undertaking a merger-acquisition transaction, the company can increase its production volume. Thus, its fixed costs will be shared on a larger number of units, enabling it to realize increasing dimensional yields when production increases more than production factors (Meier and Schier, 2003). By reaching the minimum effective size (EMI), companies increase their efficiencies and considerably reduce their costs. In addition, synergies between the different entities will result in economies of scale and economies of scope.

### **2.2. The determinants of performance related to the characteristics of the operation**

In this subsection, we discuss the factors most studied in the literature, related to the characteristics of the operations, which contributed to explain the performance. The main determinants of performance are the means of payment, the relative size of the target, the sectorial proximity, the cross-border character, the cash level and the debt level.

### *2.2.1. The cash level*

The impact of payment method choice on performance is certainly one of the issues that has most interested researchers working on mergers and acquisitions. Numerous theories and numerous models have been developed by researchers, both to explain the choice of payment method but also its impact on performance (Schlingemann, 2004). Carline et al. (2009) find a negative but not significant effect on the long-term performance of purchasers. On the other hand, the performance is often negative following the announcement of a payment by shares (Travlos, 1987). One of the explanations for this result lies in the expected future performance of the transaction and implicitly in the firm's value. However, the majority of empirical studies do not confirm this association between the cash level and the post-acquisition operational performance of the merged firms (Healy et al., 1992, Sharma and Ho, 2002, Powell and Stark, 2005, Martynova et al., 2007).

### *2.2.2. Sectorial proximity*

Healy et al (1992, 1997) and Maquiera et al.(1998) find that productivity gains are stronger when the firms involved in the groupings have similar activities (managerial expertise, economies of scale, Market, etc.). Other researchers also confirm that mergers and acquisitions having the same activity outperform diversification acquisitions and produce significantly higher earnings for Shareholders of the acquiring company. On the other hand, Ghosh (2001) and Kruse et al. (2002) are opposed to what has been cited previously and find that the operational performance of conglomerate acquisitions outperforms the performance of horizontal acquisitions in a way that the conglomerates benefit from an increase in their size and better visibility of more favorable access to capital with a reduction in the risk of bankruptcy. However, most empirical studies do not find a significant link between sectorial proximity and post-acquisition operational performance (Linn and Switzer, 2001, Sharma and Ho, 2002, Powell and Stark, 2005, Martynova et al. Carline et al., 2009).

### *2.2.3. Cross-border character*

Eun et al. (1996) point out that cross-border acquisitions could generate value for the shareholders of the acquiring companies by conquering new markets and consequently by increasing their market share especially when the managers of the acquiring company are able to take advantage of foreign market imperfections. The empirical test confirms that acquirers obtain monetary gains when they make cross-border acquisitions. Gugler et al. (2003) find that cross-border acquisitions have a significant impact on post-acquisition operational performance. Cultural differences can increase the integration problems of the target company and could lead to difficulties in managing the post-acquisition process (Schoenberg, 1999). Moeller and Schlingemann (2004), and Martynova et al. (2007) show that cross-border acquisitions have a lower post-acquisition operational performance than domestic acquisitions.

### *2.2.4. Debt level*

Jensen (1986, 1987), Harris and Raviv (1990) and Stulz (1990) find that debt has a positive impact since it reduces agency phenomenas and increases supervisory power. According to agency theory, debt plays a disciplinary role in aligning the deviant behavior of leaders. However, results on the relationship between debt level and operating performance are mixed. Harford (1999), Ghosh and Jain (2000), Kang et al. (2000) confirm the positive relationship between high indebtedness and post-acquisition performance, while Clark and Ofek (1994), Switzer (1996), Linn and Switzer (2001) find no significant relationship between high indebtedness and Post-acquisition operational performance.

### 2.3. The measures of performance

Managing, administering, organizing, piloting, managing an organization are all terms given to a single mission: to carry out the objectives and strategies of a company. However, all these terms have been pooled with one concern: to improve the Performance of the firm. In general, the technique most frequently used is that of pairing, consisting of the evolution of the operational performance indicators before and after an MA operation. The object of the study is to identify whether, on average, the operations of M&As improve or not the results of the purchaser. ROI (Return on Investment) is a financial indicator that allows you to measure and compare the return on an investment. Generally, return on investment is based on the calculation of the ratio of investment benefits to investment cost. The return on investment is an essential indicator for choosing between several projects and determining which will yield the most money compared to the initial sums invested.

$$ROI = \frac{\textit{Gain from investment} - \textit{cost of investment}}{\textit{cost of investment}}$$

For the Return on equity (ROE), it measures the return on equity in the balance sheet. This "accounting" ratio therefore measures the return on capital raised by shareholders. Return on equity measures a corporation's profitability by revealing how much profit a company generates with the money shareholders have invested. It is obtained by reporting the shareholders' net income, after deduction of tax, to the funds that the shareholders have invested.

$$\textit{Return on Equity} = \textit{Net Income/Shareholder's Equity}$$

The last indicator we are presenting is the Marris ratio, referred to as the Market to Book Ratio, is the inverse of the Book to Equity ratio, which measures the expected return on the equity market (calculated at book value). If it is greater than 1, the company creates value. The anticipated profitability by the market is greater than the profitability demanded by the capital providers assessed by the WACC -weighted average cost of capital); If it is less than 1, there is a destruction of value.

$$\textit{Marris ratio} = \textit{Market capitalization} / \textit{Equity}$$

### 3. HYPOTHESIS

Previous studies stated that the cash level, the indebtedness level, the crossborder character and the sectorial proximity affect positively the Performance while others suggested a negative relationship between them. The hypothesis is developed as follows :

- H1: The cash level impacts positively the ROI of the acquiring firms.
- H2: The level of indebtedness impacts positively the ROI of the acquiring firms
- H3: The crossborder character impacts positively the ROI of the acquiring firms.
- H4: The sectorial proximity impacts positively the ROI of the acquiring firms.
- H5: The cash level impacts positively the ROE of the acquiring firms.
- H6: The level of indebtedness impacts positively the ROE of the acquiring firms
- H7: The crossborder character impacts positively the ROE of the acquiring firms
- H8: The sectorial proximity impacts positively the ROE of the acquiring firms.
- H9: The cash level impacts positively the Marris Ratio of the acquiring firms.
- H10: The level of indebtedness impacts positively the Marris Ratio of the acquiring firms.
- H11: The crossborder character impacts positively the Marris Ratio of the acquiring firms
- H12: The sectorial proximity impacts positively the Marris Ratio of the acquiring firm

## **4. METHODOLOGY**

This chapter presents the methodology used to collect the data that have enabled us to shed light on our research problem. The first section describes the research methodology used. The second section describes our dependent and independent variables and their measurements.

### **4.1. Data Selection**

Data collection is a necessary and fundamental step in the success of any empirical study. Our source of data is the Global Mergers and Acquisitions database of Thompson Reuters-Eikon. Data is collected with regard to deals carried out by International companies with Saudi Arabian companies based in Saudi Arabia from 2010 to 2015. This period is chosen as period of investigation as it provides a long range of years to examine. Often, synergies are not realized instantly and examining 1 year back, and two years afterwards gives a better indication of the post merger performance of the acquisitions. That's why we choosed a total period of 8 years starting from 2009 to 2016 including an investigation period of 5 years. These data include the date of the announcement, the effective date, the name of the acquirer, the name of the target, the country of the acquirer, the country of the target, the RIC codes of the acquirers, the transaction value, the acquirer's attitude (friendly or hostile), the acquirer's sector of activity, the sector of activity of the target, the type of transaction (acquisition, merger or exchange offer) and percentage acquired. We obtain at the end a total sample of 83 companies.

### **4.2. Dependant variables**

#### *4.2.1. Performance Measurement*

ROI (Return on Investment) is a financial indicator that allows you to measure and compare the return on an investment. Generally, return on investment is based on the calculation of the ratio of investment benefits to investment cost. The return on investment is an essential indicator for choosing between several projects and determining which will yield the most money compared to the initial sums invested. Return on equity (ROE), it measures the return on equity in the balance sheet. Return on equity measures a corporation's profitability by revealing how much profit a company generates with the money shareholders have invested. It is obtained by reporting the shareholders' net income, after deduction of tax, to the funds that the shareholders have invested. Marris ratio : referred to as the Market to Book Ratio, is the inverse of the Book to Equity ratio, which measures the expected return on the equity market (calculated at book value). If it is greater than 1, the company creates value. The anticipated profitability by the market is greater than the profitability demanded by the capital providers assessed by the WACC - weighted average cost of capital); If it is less than 1, there is a destruction of value.

### **4.3. Independent variables**

The sectorial proximity between the acquiring company and the target company (SAMEINDUSTRY). In this study, we created a dummy variable that takes the value 1 when acquiring firms and acquired firms operate in the same industry and 0 otherwise. The cross-border character (CROSSBORDER). In this study we have created a dummy variable that takes the value 1 when the acquiring firms and the acquired firms are in different countries which means the acquiring firm is not located in Saudi Arabia and 0 if The acquiring company is located in Saudi Arabia. The level of liquidity (CASH). This variable is retrieved directly from the Thomson Eikon database and allows to have the level of liquidity that each company has at the end of each year during the 8 years of study. The level of indebtedness (DEBT RATIO). This variable is measured by the ratio of medium and long-term debt to the total assets of the acquiring firm at the end of the fiscal year.

### **4.4. Model structure**

For this study we estimated 3 models using OXMETRICS 7. OxMetrics is a family of software packages providing an integrated solution for the econometric analysis of time series,

forecasting, financial econometric modelling and statistical analysis of cross-section and panel data. A panel data (also known as longitudinal data or cross-sectional time series data) regression analysis is applied to show the relationship between dependent and independent variables. The general Panel regression models can be written as follows:

$$\text{ROI} = \beta_0 + \beta_1 \text{DEBT RATIO} + \beta_2 \text{CASH} + \beta_3 \text{SAMEINDUSTRY} + \beta_4 \text{CROSSBORDER} + \varepsilon$$

$$\text{ROE} = \beta_5 + \beta_6 \text{DEBT RATIO} + \beta_7 \text{CASH} + \beta_8 \text{SAMEINDUSTRY} + \beta_9 \text{CROSSBORDER} + \varepsilon$$

$$\text{MARRIS RATIO} = \beta_{10} + \beta_{11} \text{DEBT RATIO} + \beta_{12} \text{CASH} + \beta_{13} \text{SAMEINDUSTRY} + \beta_{14} \text{CROSSBORDER} + \varepsilon$$

## 5. EMPIRICAL RESULTS

### 5.1. Descriptive analysis

Table 1 presents the descriptive statistics for each explanatory variable. For each variable, we calculated the mean, standard deviation, maximum and minimum. These descriptive statistics indicate that these takeover transactions are, on average,

*Table 1 : Descriptive Statistics*

	ROI	ROE	MARRIS RATIO	CASH	DEBT RATIO	SAMEINDUSTRY	CROSSBOR DER
Min	-120,1	-156,63	-126,82	0,027	0	0	0
Max	65,31	72,08	16,5	19167,828	0,7099	1	1
Mean	4.8646	6.3120	1.5134	631.19	0.30453	0.77612	0.54229
Standard Deviation	16.386	22.041	6.8658	1916.4	0.27462	0.41736	0.49883

The average value of ROI is 4,86 varying between -120,1 and 65,31, which shows that the return on investment is very low in the acquiring firms. Same remark for the Return on equity which average is 6,31 for values varying between -156,63 and 72,08 revealing a very low level of return on equity. Furthermore the statistics show that the number of acquiring firms from foreign countries are dominant in ours ample (more than 50% ). Concerning the sectorial proximity, we can see that more than 70% of the companies acquire firms which operate in the same field. Then, as part of the descriptive analysis of the data, we performed a dynamic cross-matrix on excel to identify the ROI, ROE and Marris RATIO means for the mergers taking place in the same year, and then compare each mean with the corresponding reference years (2 years before and 2 up to 5 years after the Merger ). We can clearly see that, for all the years of the study (2010,2011, 2012, 2013, 2014 and 2015) and for our 3 performance indicators (ROI, ROE and MARRIS RATIO) the performance falls heavily starting from the date of the M&A's transaction and continues to fall for up to 3 years after and then begin to improve slightly afterwards. We can say that generally, and by relying on the 3 performance indicators we choosed for our research, that the mergers and acquisitions in Saudi Arabia aren't value creators.

### 5.2. Correlation

In order to realize the regressions, it is essential to study the correlations between the different variables of the model and to test the problem of multicollinearity. In fact, a major problem that could bias the results of our model lies in the multicollinearity between variables. Thus, it seems essential to ensure their independence.

Table 3: Correlation Matrix

Correlation matrix:

	CROSSBORDER	SAMEINDUSTRY	Cash	Debt Ratio
CROSSBORDER	1.0000	0.093501	0.26399	-0.069697
SAMEINDUSTRY	0.093501	1.0000	0.056396	-0.031428
Cash	0.26399	0.056396	1.0000	-0.074181
Debt Ratio	-0.069697	-0.031428	-0.074181	1.0000

According to the correlation matrix there is low correlation between the independent variables of our model. In so far as all the correlation coefficients are less than 0.26, way far from the limit drawn by Kervin (1992). Due to the complexity of the panel data regressions, we normally estimate two regressions, one with fixed effects method and the other with random effects method then we compare the two methods using Hausman test. But in our case, we introduced 2 dummy variables in our regression. In this case the fixed effect method will not be appropriate and we will use from the start the random effect method named GLS (using within/ between) in the model PCGIVE of OxMETRICS software.

Table 4 : Results of the regression with ROI as a dependant variable.

ROI	Coefficient	Std.error	t-value	t-prob
SAMEINDUSTRY	-3,524	2,588	-1,36	0,174
CROSSBORDER	-2,81	2,193	-1,28	0,201
Cash	0,0012	0,0004	2,83	0,005
Debt Ratio	-19,85	3,95	-5,02	0,000
Constant	15,04	2,72	5,52	0,000
R2	9,31			

Table 4 shows the results of the regression analysis for the hypothesized relationship between the operation's characteristics and the Return on investment. The p value is significant at the 10, 5 and 1 per cent level respectively for the Cash and Debt ratio. We can say that Debt ratio impacts strongly the return on investment (-19,85), the more the firm is indebted the less it is its ROI. This result is not consistent with the assumption that debt has a positive impact on performance since it reduces agency costs and increases management control. The cash level, which coefficient is near to zero, even with a significant p-value, doesn't impact much the ROI. The Sameindustry and crossborder characteristics have a negative impact on ROI but with non-significant p-value. To sum up, for the hypothesis relative to ROI performance, we can say that only Cash level impacts positively the ROI and the debt ratio impacts negatively the ROI.

Table 5 : Results of the regression with ROE as a dependant variable.

ROE	Coefficient	Std.error	t-value	t-prob
SAMEINDUSTRY	-4,97	3,86	-1,29	0,09
CROSSBORDER	-2,77	3,28	-0,846	0,398
Cash	0,0017	0,0006	2,59	0,010
Debt Ratio	-35,28	6,086	-5,80	0,000
Constant	21,65	4,089	5,30	0,000
R2	10,86			

Table 5 shows the results of the regression analysis for the hypothesized relationship between the operation's characteristics and the Return on equity.

The p-value is significant at the 5 and 10 per cent level for the Cash and at the 1, 5 and 10 per cent debt ratio. We can say that Debt ratio impacts strongly the return on investment by -35,28. Increased debt increases the leverage factor in a company. During normal or boom times, leverage results in exponential profit returns. During recessions, leverage can result in exponential losses, as well which is the case in our study. The cash level, which coefficient is near to zero, even with a significant p-value, doesn't affect much the ROE. The same industry characteristic affects negatively the return on equity by -4,97 at a level of 10 per cent. To sum up, for the hypothesis relative to ROE performance, we can say that only Cash level impacts positively the ROE and the debt ratio impacts negatively the ROI as well as the sectorial proximity.

*Table 6 : Results of the regression with Marris Ratio as a dependant variable.*

Marris Ratio	Coefficient	Std.error	t-value	t-prob
SAMEINDUSTRY	-0,19	0,7231	-0,264	0,792
CROSSBORDER	-0,82	0,625	-1,32	0,187
Cash	0,00037	0,00016	2,30	0,022
Debt Ratio	-1,506	1,305	-1,15	0,249
Constant	2,416	0,784	3,08	0,002
R2	2,63			

Table 6 shows the results of the regression analysis for the hypothesized relationship between the operation's characteristics and the Marris Ratio. The p-value is significant only for the cash at a level of 5 per cent, but with a very negligible coefficient (0,00004). All the other independant variables (SAMEINDUSTRY, CROSSBORDER, and Debt Ratio) have a negative coefficient respectively ( -0,19 ; -0,82 ; -1,506) but with p-value > 0,10 . Which means they don't have significant impact on performance. To sum up, for the hypothesis relative to Marris Ratio performance, we can say that only Cash level impacts positively the Marris Ratio. For the other variables, they don't have significant impact on Marris ratio.

## 6. CONCLUSION

Mergers and acquisitions are an important area of research in finance. The actual performance of these operations always raises so many questions. Currently, with the renewed growth of these operations, the evaluation of their impacts remains all the more essential. Much research has been done to determine whether M & As are profitable. In the short term, a consensus tends to recognize their positive effect for the shareholders of the target, while they are not significant for the shareholders of the acquirer. In the long term, the different methodologies used do not allow us to decide on the performance of mergers and acquisitions. In our paper, we focused on the impact of the characteristics of the transaction on the corporate financial performance of mergers and acquisitions, that is Return on investment, return on equity and Marris Ratio, using data on the deals occurred during the period 2010-2015 in Saudi Arabia. Panel data and exactly random effect method are applied to carry out empirical analysis. In this paper, we examine whether specific merger characteristics impact the M&A's performance. The results show that the performance is negatively influenced mainly by the level of debt and slightly by the sectorial proximity concerning the return on equity. The cash level has a very slight positive impact tending to zero. On the other hand, other explanatory factors do not have a significant effect on performance for the acquiring firm. Beyond the measurement of performance and its determinants, the motivations behind the development of mergers and acquisitions are also essential; They can effectively influence their long-term success. One of the main motivations noted in the literature is the personal interest of managers. Thus, the study of these engines is also likely to bring some clarification on the paradox of the blossoming of mergers and acquisitions despite their mixed results. In future research, it would be interesting to take into



account some reflections. First, it will be of interest to extend this analysis to other emerging countries in order to have a benchmark. Secondly, new business and sector specific variables should be added, including the ownership structure of firm's capital and the environment in which firms operate, and other characteristics of the operation such as the friendly or hostile nature of the operation and the geographic proximity.

#### LITERATURE:

1. Andrade, Gregor, Mark L. Mitchell And Erik Stafford (2001). "New Evidence And Perspectives On Mergers." *Journal Of Economic Perspectives*, Vol. 15, No. 2, Pp.103-120.
2. Aybar, B., & Ficici, A. (2009). *Cross-Border Acquisitions And Firm Value: An Analysis Of Emerging-Market Multinationals*. *Journal Of International Business Studies*, 40(8): 1317–1338.
3. Bourguignon A., (1995), « *Peut-On Définir La Performance ?* », *Revue Française De Comptabilité*, Juillet- Août, P. 61-66.
4. Capron, L. (1999). The Long-Term Performance Of Horizontal Acquisitions. *Strategic Management Journal*, 20(11), 987 1018.
5. Jensen M. C. (1986), « Agency Costs of Free Cash Flow, Corporate Finance, and Takeovers », *The American Economic Review* Vol. 76, No. 2
6. Jensen, Michael And Richard Ruback (1983). "The Market For Corporate Control: The Scientific Evidence." *Journal Of Financial Economics*, Vol. 11, No. 1, Pp. 5-50
7. Lins, Karl And Henri Servaes (1999). "International Evidence On The Value Of Corporate Diversification." *Journal Of Finance*, Vol. 54, No. 6, Pp. 2215-2239.
8. Marris R. (1964), "A Century Of Corporate Takeovers: What Have We Learned And Where Do We Stand?", *Journal Of Banking And Finance* 32, Pp. 2148-2177.
9. Melicher R. M. Et Rush D. F. (1974), « *Evidence On The Acquisition-Related Performance Of Conglomerate Firms* », *Journal Of Finance*, Vol. 29, N° 1, P. 141-149.
10. Michael Lubatkin, *Mergers And The Performance Of The Acquiring Firm*, *Academy Of Management Review*, 1983, Vol. 8, No. 2, 218-225.
11. Moeller, S. B., Schlingemann, F. P., & Stulz, R. M. (2004). Firm size and the gains from acquisitions, *Journal of Financial Economics* 73 (2004) 201–228
12. Shleifer A. Et Vishny R. W. (1989), « *Management Entrenchment* », *Journal Of Financial Economics*, Vol. 25, N° 1, P. 123-139.
13. Steiner, P, 1975, "Mergers: Motives, Effects, Policies", *University Of Michigan Press*.
14. Takeovers », *American Economic Review*, Vol. 76, N° 2, P. 323-329.
15. Trautwein F. (1990), « *Merger Motives And Merger Prescriptions* », *Strategic Management Journal*, Vol. 11, N° 4, P. 283-295.
16. Zhu, P., Jog, V., & Otchere, I. (2011). *Partial Acquisitions In Emerging Markets: A Test Of The Strategic Market Entry And Corporate Control Hypotheses*. *Journal Of Corporate Finance*, 17(2): 288–305.
17. Zollo M., Meier D. (2008), « *What Is M&A Performance?* », *Academy Of Management Perspective*, Vol. 22, N°3, P. 55-77.

## PUBLIC CONSULTATIONS IN THE LIGHT OF CO-MANAGEMENT IN LOCAL GOVERNMENT

**Agnieszka Smalec**

*University of Szczecin, Faculty of Management and Economics of Services, Poland  
agnieszka.smalec@wzieu.pl*

**Marzena Wanagos**

*Gdynia Maritime University, Faculty of Entrepreneurship and Commodity Science, Poland  
m.wanagos@wpit.am.gdynia.pl*

### **ABSTRACT**

*Public consultations are a commonly used form of engaging local communities in public life. They may regard various matters relevant to a particular community. They include information, opinion research and a debate. Their effect is to develop the most optimal solution for interested parties. Thanks to them, self-governments on the one hand inform local citizens about their intentions, on the other – they allow the citizens to express themselves in a given matter. Well-conducted public consultations build a sense of local community and shared responsibility for the decision. Inhabitants who unite around common for them important for the implementation of tasks can affect the level of social dialogue and contribute to the feeling of greater responsibility for the use of public funds and transparency of decisions. The main goal of the article is therefore to draw attention to the importance of social consultations – not only mandatory - in the management of the local government unit. The article mainly used the method of desk research in the form of literature analysis of the subject, industry reports and exploitation of online resources, as well as case studies.*

**Keywords:** *citizens, local government, management, public consultations*

### **1. INTRODUCTION**

In the current concepts of management in public administration, including a self-government, a citizen is treated as a client for whom public services are created and directed, and as a partner who has a control function towards the state and activities carried out by the local government. The local authority is to support various forms of civic activity, creating various agreements of organizations, institutions and citizens. The citizen became an active subject in a decision making process. In recent years, active supplementation of the traditional tripartite dialogue (with the participation of trade unions, employers and public authorities) with non-governmental organizations and individual citizens, can be observed. Different degree of involvement of citizens in the decision-making process concerning public life can be observed. Social consultation is one of the forms of citizen involvement. Public consultation is a process of dialogue between representatives of the authorities and residents, aimed at gathering votes of residents and on the basis of which the authorities take optimal decisions in public matters. On the so-called Arnstein's (2012) participation ladder, arranging various forms in terms of the real influence of residents on public decisions, public consultations are located more or less in the middle, i.e. they do not allow residents to directly influence decisions (this is ultimately reserved for the authorities), but they are also doing more than just informing citizens about the planned activities - they assume mutual communication, establishing relations between the residents and the authorities and administration. They contain information, opinion polls, and a debate. The aim of the article is to emphasize the role of social consultations in the management of the local government unit. The theoretical part of the article mainly used the desk research method in the form of literature analysis of the subject, industry reports and exploitation of online resources. Theoretical considerations have been supported with case studies.

## 2. PUBLIC CONSULTATIONS AS A FORM OF CO-MANAGEMENT

Social participation, implemented as a form of co-management at the local level in terms of its types, can take the following forms (Kudłacz, Hołuj, 2015, p. 230):

- local government elections – residents choose, from a strictly defined catalog, persons to be part of municipal administrative bodies;
- referendum – participation on the conditions of conduct which are subject to the provisions of law; it may be at the initiative of the residents or as a vote; its results are binding if the thresholds indicated in legal provisions regarding the attendance or the share of votes cast have been exceeded;
- social consultations that fulfill many functions; they are organized in various ways;
- obtaining opinions/information from the community – in accordance with the procedures provided for in law, for example, comments on draft zoning plans; this form has no binding legal character;
- other forms of obtaining information from the community – those that do not result from the situations specified in the procedures or legal regulations; their use depends on decision-makers;
- civic budget – it is binding in the absence of other obstacles that would make it impossible to implement the announced and confirmed draft.

The International Association for Public Participation defines five levels (from the weakest to the strongest influence of local citizens) involving citizens in the decision-making process (Maszkowska, Sztop-Rutkowska, 2013, pp. 51–52), such as:

1. Informing – that is, providing citizens with reliable knowledge, objective information on a specific problem, as well as proposals for solving it, information to understand the problem. It is a one-way message.
2. Consulting – organizing a two-way communication process: authority–citizen and a citizen–authority, as well as a readiness to apply specific solutions, to take account of remarks; gaining knowledge about citizens' opinions and reactions to proposed solutions or decisions made; creation of consultative teams, which consist of representatives of various opinion-forming groups.
3. Inclusion – inclusion of comments, opinions, solutions or their elements in public policies being created, implemented or monitored; involving citizens in the entire policy development process, ensuring that the needs or problems are heard and taken into account when making decisions.
4. Cooperation – partnership, involvement of social and economic partners or citizens at every stage of the decision-making process, regarding all aspects, with the selection of the best solution.
5. Empowering (deciding) – means giving (putting down) a final decision to citizens.

The term consultation derives from the Latin *consulto* – ask for advice, consult and *consultatio* – a question for advice. Public consultation is a form of co-management of the local government unit and joint responsibility for the decisions made. It is "... an institution of direct democracy, which consists in expressing opinions by members of a collective on the subject matter presented to it (...) while making the most important decisions" (Ferens, Kondas, Matysiak, Rzeźnik, Szyrski, 2010, p. 13). According to D. Długosz and J. Wygnański (2005, p. 23), social consultations "are a way to obtain opinions, positions, proposals, etc. from entities (institutions or persons) who in some way will affect, directly or indirectly, the effects of the proposed by the administration of activities." Public consultation is sometimes a difficult process, in which representatives of local authorities present their plans and ideas to citizens and collect opinions about them from the public.

Residents can participate in making decisions for the benefit of the whole community. They are considered a form of direct democracy, although they are only consultative and not imperative [Haładyj, 2014, p. 680]. Public consultations allow citizens to be involved in the decision-making process and to get an answer to the question of what constitutes important issues for local communities. Residents participating in them have the opportunity to improve their quality of life, making local authorities aware of how they perceive particular issues, what they expect, what their opinions on a given topic are. Before making a decision to carry them out, it is necessary to consider what they are supposed to concern, what are the needs of residents, what activities have already been undertaken in a given area – therefore it is worth preparing a diagnosis of the situation. Public consultations are regulated by the provisions of local government laws. In principle, everything can be consulted. They may refer to legal changes, investments, changes in the organization of public life, and how to solve a problem that is important for a given community. It should be emphasized that in each of the topics the consultations may be slightly different and the role of the residents may be different. It is worth noting that the following forms of public activity are not, although they do reflect the public mood and may be the basis for announcing social consultations, social consultations themselves (Gawroński, 2010, p. 29):

- discussions (articles, retorts, explanations) and so-called news in the press,
- periodic hearing of complaints and suggestions by the commune head (mayor, president),
- admission of residents by councilors in individual cases,
- rallies, demonstrations, strikes, protest actions,
- verbal disputes of dissatisfied clients with municipality's officials.

The purpose of social consultations is to reach the broad audience and the willingness to read its opinion to improve the quality of the solutions being prepared, even if it would mean their abandonment. On the other hand, it should be emphasized that consultations are not negotiations – the final decision is in the hands of public administration. Public consultation is a voluntary tool recommended to local governments for use. They are supposed to enable achieving higher efficiency and accuracy of decision-making processes, involve residents in the municipality management process, gain social understanding and acceptance for upcoming, planned solutions. Municipalities, by way of a resolution, determine how they should be held. Consultations are also obligatory – required by law, e.g. in the act on planning and spatial development, which imposes an obligation to carry them out during the process of adopting local spatial development plans or a study of conditions and directions for spatial development. The Act on municipal self-government also shows that obligatory social consultations with residents of the commune occur when there is a change of municipal boundaries or city borders, consisting in excluding the area or part of the auxiliary unit area of the commune and its inclusion in the neighboring auxiliary unit of the commune or neighboring commune (Article 4a, paragraph 2). The European Charter of Local Self-Government (EKSL) also regulates the issue of social consultations, i.e. the participation of residents in public life. The Council of Europe does not impose any ready-made solutions, but refers to the ways included in the national law, which should specify in detail the subject or form of social consultations (Podstawy prawne konsultacji..., 2012). The initiator of social consultations may be a council, the president of the city or, in some cases, also residents or other entities, e.g. in Lublin it must be a group of 700 residents with an active electoral right; in Szczecin – at least 400 inhabitants or a housing estate council or youth council (Sidor, 2014, p. 898). A frequent problem in conducting social consultations is the participation of the residents themselves, as the consultations are sometimes treated as a dialogue with only non-governmental organizations. Low activity may also result from the lack of information and validity of the topic, which may be perceived as too trivial.

Citizens can also come with their own fears and sometimes with the attitude "we deserve". It's worth taking care of uploading full information on websites concerning, among others, the topic, the course of consultations, deadlines, if necessary, expand the knowledge of the consultation participants, use an accessible form of communication. It is important to choose attractive forms of dialogue with residents so that they are more likely to take part in it. An important problem in the practice of social consultations is sometimes too short a time to carry them out, they can sometimes lengthen the decision-making process by delaying the introduction of new solutions. Public consultations are also often carried out under the responsibility of officials who sometimes feel it as an additional burden. One must, therefore, be aware of certain limitations and plan such activities precisely. It should be remembered that the aim is not only to consult, but to develop a solution that takes into account the needs of residents and the possibilities of local governments. The cooperation of various departments at the office is important in this respect. An intermediary in the process of public consultation (to facilitate communication), may be external entities, e.g. NGOs, independent experts or representatives of the scientific community.

### **3. THE PROCESS AND MAIN PRINCIPLES OF CONDUCTING SOCIAL CONSULTATIONS**

Public consultation is a whole that, like every process, has its beginning, development stage and ending. The first stage is to prepare the consultation process, taking into account the formal and legal framework, organizational and financial framework, i.e. specification of the subject, recipients, schedule, form or choice of the coordinating team. Consultations should be organized at the earliest possible decision-making stage, because it is discouragingly aware that everything is already decided, and the whole process takes place only to meet the formal and legal requirement. The basic part of social consultations begins with an information of an intention to conduct them and announcing the subject. What is important here is the right choice of different information channels adapted to the recipients, e.g. the Internet, press, leaflets, posters, information meetings. The next step (crucial from the perspective of the purpose of organizing consultations) is to consult. The basic condition is to allocate adequate time to submit opinions to allow all interested parties to familiarize themselves with their subject and take a position. The choice of consultation methods is also important. Passive forms, such as submitting comments via the Internet or by post, should be complemented with more active ones, creating a space for sharing arguments, e.g. meetings, workshops, discussion on online forums. It is important that consultations do not interfere with the occupational duties of residents. The next stage, unfortunately often neglected, is announcing information about the results of consultations. Residents who give decision-makers their opinions want to receive feedback. Therefore, it is a good practice to publicize (for example on the website) the results of consultations in the form of summaries of accepted and rejected comments, which should be justified. The final stage of the process should be evaluation, which will allow to determine the extent to which the set goals of the consultation have been achieved and what is the reason for that. In addition to the legal conditions of public consultations, it is important that they are carried out in accordance with established rules. It is important to acquire relevant knowledge both from experts in a given field and from residents, their representatives or organizations and social activists. Bearing in mind the reliability of consultations conducted in EU member states and in order to indicate the basic rules of good consultation practices, the standards for the consultation minimum have been developed by the European Commission (2002). They mainly concern the way of informing e residents about consultations. These remarks are also aimed at providing equal and full access to the participation of stakeholders to participate in consultations, that is, conducting consultations via means of communication adapted to the consultations and expectations of their participants.

In June 2012, in order to systematize activities, a group of governmental and non-governmental experts in cooperation with the Ministry of Administration and Digitization (Chrzanowski, Rościszewska, 2015, p. 10) prepared a set of recommendations, guidelines on how to conduct a successful consultation, i.e. developed "Seven principles of social consultations", which discuss the main principles and objectives that they should meet. The development of these principles is the "Canon of local social consultations" developed in 2014, i.e. a kind of signpost, how to organize good public consultations, how to create their regulations and what should be included and how the consultation procedure should look step by step. The Seven Principles of Social Consultation consist of (Kanon..., 2018; Siedem..., 2013): good faith, universality, transparency, responsiveness, coordination, predictability and respect for the general interest. The principle of good faith means that consultations are conducted in a spirit of dialogue culture, with pure intentions, without political manipulation. Each of the interested parties is heard, demonstrates the will to understand different reasons, the listeners do not deny a different point of view. Consultants should be inclined to change their opinions under the influence of convincing arguments. The consultant should clearly present the subject, time and date of the consultation results. The materials must be reliably prepared – succinctly, clearly and comprehensibly. The rule of universality refers to the availability of consultations. Everyone interested in the topic has the opportunity to get information about them, has the right to take part in them and express their opinion. The organizer disseminates information about consultations in a public place, for example on a website (often specially dedicated to consultations), in local and national press and on bulletin boards. The language should be understandable and simple, so that the information reaches the widest possible range of citizens, not only specialists and experts in a given field. Opinions should be collected in a way relevant to the subject of the consultations. Transparency of public consultations means informing about their purpose, rules, course and outcome; it is also important to know who views what and why. All submitted comments and their authors' names are public, as well as the organizer's answers to them. The organizer also decides whether to allow anonymous opinions for discussion. However, they can not be accepted while working on draft legal acts. Each participant who submits an opinion should receive a substantive answer within a reasonable time, which does not exclude a collective answer. This is in line with the principle of responsiveness. The summary of consultations, which should be within the given deadline, must take the form of a publicly available document with opinions and questions asked during the consultation and substantive answers to them. Individuals who have submitted their comments / suggestions should learn about this document. This form of frequent publication of documents helps in conducting further discussions on a given project. In order for the consultations to run smoothly, it is worth appointing their organizer/host. According to the principle of coordination, it should be a person who has decision-making possibilities depending on the scope and subject of consultations. The host should be able to engage administration subordinate to him in the consultation process. Well-planned and ongoing public consultations should take place in a timely manner; be based on the legibility of specific rules. The consultations organized in this way meet the next rule - predictability. Well-planned consultations should not be shorter than seven days, they should prevent social conflicts and not start just as they occur; public consultations should not be carried out when the authorities want barely to obtain from the citizens an acceptance of the decision already taken; they should be proactive (pre-emptive) and not reactive. The last established principle is respect for general good and public interest. It refers to making decisions for the benefit of the general public and not just a small group of interested people, or to be a mereresponse to pressure. This is a principle that also implements the principles of equality and mutual listening to the opinions of all parties. The public interest, including those who did not take part in consultations, must prevail. The application of the above-mentioned principles can take various forms – from very basic (passive), through wider

(active and multi-stage), to the most extensive (combining various techniques and possible wide open public debate) and the way they are used depends on the impact of the solution on citizens. The principle of proportionality is important, i.e. the more important the regulations may be for citizens or have more influence on them, the more time and energy should be put into public consultation. These rules provide a framework for all consultation processes - regardless of their subject or the administrative level at which they are conducted. Constructive dialogue and exchange of opinions is important to find the best solutions for everyone. A thoroughly prepared consultation will also encourage citizens to take part in them. The transparency of procedures and easy access to information are important. These postulates can be quite easily implemented thanks to online platforms that are easy to use and widely available. The transmission of information may take place in various ways, including via the Internet, local media, bulletin boards, meetings with residents. The authority can not assume that the scheme of social consultations that operates in another community will also work for him. It is important that consultations do not interfere with the occupational duties of residents. The place of consultation must be easily accessible also for people with disabilities and provide good conditions for discussion.

#### **4. SOCIAL CONSULTATIONS IN PRACTICE**

As mentioned previously, there may be various topic of public consultations. The subject of consultations, however, can not be an abstract issue which does not function in the minds of citizens as such because they do not experience or do not realize its existence on a daily basis. The scope of the social consultation subjects should include issues relevant to the general population, such as development strategies, programs, budget, as well as take into account the specificity of a commune or a region (Zychowicz, 2014, p. 175). One of the more frequently discussed topics are those that concern environmental protection or the adaptation of local spatial development plans. An example of these could be the debate about the development of the E. Szyca stadium in Poznań. Surveys, group discussions (focus) and elements of public debate were used here. In England and Wales, social consultations are an integral part of the spatial planning and development strategies. In this country, they are not treated only as a chance for the social partners to speak, but as a basic element of creating effective and rational solutions that respond to the needs of society. They have a very wide range. Public authorities do not limit them only to the written expression of the social partners' opinions, but above all to their active involvement in current affairs. The topic of social consultations with the residents, organized from the perspective of local governments, are also issues of planning better communication in the city/ town, e.g. changing the location of stops or the frequency of public transport vehicles. During consultations regarding environmental protection, for example in the case of Poznań city, as part of the Noise Protection Programme the residents could submit their comments and conclusions through a consultation platform, where the representatives of the program's contractor (a team of academics from the Adam Mickiewicz University) answered the residents' queries and comments. The consultation lasted for 21 days (see: Program ochrony..., 2018). An interesting example of social consultations, quite extended in time (from December 2009 until the end of 2011) is the Forest Planning Rule, which was organised by The Forest Service Agency in the USA (see: High Level..., 2010; Makowska, 2011). It is a directive concerning the creation of Land Management Plans by individual units included in the US The National Forest System. In the Minister of Agriculture's announcement which had started the consultation process, 8 priorities were proposed which could be the basis for the creation of new "Forest Planning Principles". Each priority was accompanied by a justification and included questions for discussion. The decision was made on a participatory approach to the development process, i.e. by hearing the comments and opinions of interested parties.

It was to be based from the beginning on the principles of cooperation, transparency and participation. The consultation covered various institutions and social groups, including representatives of state and federal administration agencies, local governments, entrepreneurs, industry representatives, non-governmental organizations, scientists, residents (including Native Indian communities), forest users, and media representatives. At various stages, various methods and techniques were used the purpose of which was to consult citizens, such as: a website, a dedicated blog, comments on published documents, regional meetings, national meetings, a scientific forum, a public information bulletin, press releases sent to the local press, websites of other national and regional public agencies, letter invitations. The next stages of the process were based on feedback and conclusions obtained in previous steps. All applications collected during individual stages were included in reports, which were further forwarded to the Forest Service Agency and posted on the website. The evaluation of individual activities was immediately utilised to determine the participatory creation of forest management plans in the final document. The user satisfaction survey tool was also used. During all stages of the participatory process, the Forest Service Agency cooperated with the US Institute for Environmental Conflict Resolution, IECR and external consultancy institutions. This is an example of a good consultation initiative, which is based on openness to feedback. The Forest Service Agency used all the collected remarks to develop the draft of "Principles of Forest Planning" and on February 10th 2011 published its proposal in the public register. In total, over 3,000 people participated in all consultative activities. Another example of public consultations carried out each year in Warsaw (since 2004) is the creation, in collaboration with local organizations, of the Cooperation Programme – a document setting out the principles and areas of cooperation of non-governmental organizations with local self-government (see: Krzyżanowska, 2011). The President's Plenipotentiary of the Capital City of Warsaw is responsible for carrying them out in cooperation with NGOs together with the Center for Social Communication. The document consultation process consists of six stages: 1) invitation of stakeholders associated with the Programme (NGOs and civil servants) to participate in the consultation process; 2) filling in information tables with notes and comments by interested parties; 3) collecting all comments; 4) work of the Team for a Cooperation Programme composed of representatives of the 3rd sector and self-government officials on the proposed remarks; 5) creation of a new document including (or not) the sent comments; 6) making changes and approving the document by the appropriate units of the City Hall. The consultation process does not use specialized tools to involve residents and members of non-governmental organizations, only a table to be completed consisting of four columns: the paragraph to which the note refers, the proposed change, its justification and information about the person/institution submitting it. However, it is important to use the organizational potential of Warsaw NGOs, including mainly non-governmental organizations, district Public Dialogue Commission, Public Dialogue Commission and Social Dialogue Forum, as well as individual offices of districts and offices. It was important to apply the principles of subsidiarity, sovereignty, partnership, efficiency and fair competition and publicity. The starting point of the consultation process is the Cooperation Program in force in the previous year. Important in this process of public consultation is the willingness of officials of various levels from the City Hall to work together with non-governmental organizations on this document. As a result, the process has a participatory nature, it gives the opportunity for all interested stakeholders to join the work. The final version of the document is worked out by both parties who use the "Programme". In Warsaw, due to the entry into force of the regulation introducing a new category of waste – bio-waste – at the turn of October and November 2017, a public consultation was carried out (see: Raport..., 2018; Wyrzuć..., 2018). Their main goal was to inform about the changes – to get to know the inhabitants' opinions on the ways of collecting bio-waste and to identify needs in relation to the planned educational campaign on waste



segregation. The subject of the consultations was the draft of new regulations for maintaining cleanliness and order in the capital city of the capital city of Warsaw. Residents could submit their comments by e-mail or by post. The consultations had general urban character. 10 informational and consultational meetings with representatives of the city hall in various districts were organized to reach the largest possible group of city residents. The main element of the information campaign was a poster distributed in different districts. With changes you could familiarise yourself as well as submit comments, also during the Zero Waste Fair event. Many of the submitted comments (summarized, with justification for their selection or rejection) were taken into account, e.g. the city extended the period of green waste collection, allowed the use of larger waste containers for single-family houses and introduced the obligation of regular cleaning of containers. The residents were involved in these consultations so that everyone could express their views on maintaining order and cleanliness in their city. An example of similar actions regarding the involvement of residents in the process of creating a new waste and water management program was the Let's Talk Waste consultancy, which was conducted at the turn of February–June 2014 in the Mornington Peninsula in the state of Victoria, Australia (see: Let's Talk Waste..., 2015; 2016). The most important context of the change was the problem with the local rubbish dump, which was supposed to overflow in the next few years and was also the largest producer of greenhouse gases whose emissions were to be reduced. A special online forum was created for the needs of consultations. Thanks to it, residents could participate in discussions on key issues related to waste management, as well as gain access to data: reports, presentations and films on the issues discussed. An important part of the consultations were discussion panels (deliberative fora) in the form of two three-hour meetings. Participants represented almost all regions of the county, experts also participated in the forum (including in the field of waste storage) and representatives of local authorities. The first meeting consisted in sharing knowledge, so that everyone could understand the problems being discussed, and the second one was voting using a five-point scale. A telephone survey was also conducted on a representative sample of over 300 people, chosen randomly. Throughout the consultation period, residents could submit their comments by telephone, e-mail or post. Residents were kept informed about the progress of the process. To ensure its transparency, many actions have been taken, including press conferences were organized, information was published in local media and the Internet, direct contacts were made with representatives of schools and local non-governmental organizations (including those dealing with the environment). The opinions received in the process were reflected in the decisions of the authorities, including the local landfill has been closed. Very often, many offices, departments or municipal units are involved in public consultations. It is worth to clearly mark the division of their duties at the very beginning of the process. Many cities, such as Krakow, solve this by means of ordinances. As can be observed, various techniques and methods can be used during consultations, but the basic condition for the success of the consultation process is the use of conclusions resulting from the dialogue with interested parties, as well as their notification, i.e. making the results public. Social consultations should be accompanied by an information campaign addressed to interested parties so that everyone can have the proper knowledge to take part in a joint dialogue. However, it should be emphasized that even with the correct organization of consultations and an appropriate information campaign there is no guarantee that the residents will want to participate in the talks; sometimes, a too detailed or specialized subject can make the consultation fail.

## **5. CONCLUSION**

Well-conducted public consultations, in accordance with relevant practices and social needs, are an important part of the process of creating a local community. The consultations are aimed at making the residents more involved in public life and increasing the sense of shared

responsibility for decision making process. The participation of citizens in public decisions creates conditions for mutual learning, broadens horizons and allows viewing the issue in question from different perspectives. The use of tools for participation, including social consultations, allows different groups to get to know each other and to better diagnose actual needs. Public consultations should be carried out at this stage of decision-making so that it is possible to take the opinions of the community into account. They must be pre-emptive, that is, their initiation is to be an integral, multi-stage element of management in local governments, and not a "rescue mission", and they are not to be used to barely communicate local government's decisions. Various communication channels may be utilized, however, they must be impartial and reliable. Public consultations can be carried out using various forms, such as open meetings, meetings and public hearings, submission of comments in writing, appointment of consultative bodies, street surveys, online surveys, workshops with interested groups or conferences with expert participation. It is important for the chosen form to allow dialogue, especially if the topic is not easy. The most important feature of the consultation is the factual discussion of the residents, in which each opinion is respected and taken into account in the final decision. Direct meetings at the very place where the subject matter of the consultation is relevant are often the best. It is important in public consultations to acquire relevant knowledge from experts in a given field as well as from residents, their representatives or organizations and social activists. Making use of the conclusions drawn from the dialogue with residents is a basic condition for the success of the consultation process; it should be emphasized that although there are provisions regulating the need for consultations, there are no regulations that would oblige local governments to take into account comments or opinions of residents. Therefore, if the authorities are open to this form of communication with the citizens, and see the benefits of it, they will strive for the most widespread public consultations. Otherwise, the consultations will either not take place at all or assume a facade form.

#### **LITERATURE:**

1. Arnstein, S.R. (2012). *Drabina partycypacji*. In *Partycypacja. Przewodnik krytyki politycznej*. Warszawa: Wydawnictwo Krytyki Politycznej.
2. Chrzanowski, O., Rościszewska, E. (2015). *Konsultacje okielznane*. FISE. Retrieved 20.10.2018 from [http://partycypacjaobywatelska.pl/wp-content/uploads/2015/12/1\\_konsultacje\\_okielznane.pdf](http://partycypacjaobywatelska.pl/wp-content/uploads/2015/12/1_konsultacje_okielznane.pdf).
3. Długosz, D., Wygnański, J.J. (2005). *Obywatele współdecydują. Przewodnik po partycypacji społecznej*. Warszawa.
4. European Charter of Local Self-Government (2018). Retrieved 20.10.2018 from <https://www.coe.int/en/web/conventions/full-list/-/conventions/treaty/122>.
5. European Commission (2002). *Towards a reinforced culture of consultation and dialogue – General principles and minimum standards for consultation of interested parties by the Commission*. Bruksela. Retrieved 20.10.2018 from [http://ec.europa.eu/civil\\_society/consultation\\_standards](http://ec.europa.eu/civil_society/consultation_standards).
6. Ferens, R. Kondas, I. Matysiak, G. Rzeźnik, M. Szyrski (2010). *Jak prowadzić konsultacje społeczne w samorządach? Zasady i najlepsze praktyki współpracy samorządów z przedstawicielami społeczności lokalnych. Przewodnik dla samorządów*. Warszawa: FRDL.
7. Gawroński, H. (2010). Konsultacje społeczne jako forma partycypacji w zarządzaniu strategicznym jednostkami samorządu terytorialnego. *Współczesne Zarządzanie*, No. 1.

8. Haładyj, A. (2014). Konsultacje czy partycypacja? Refleksje terminologiczne w odniesieniu do udziału społeczeństwa w ochronie środowiska. In B. Dolnicki (ed.), *Partycypacja społeczna w samorządzie terytorialnym*. Warszawa: Lex a Wolters Kluwer business.
9. *High Level Summary of Collaborative Input for Forest Planning Rule Revision, Spring 2010* (2010). Prepared by Meridian Institute. Retrieved 12.10.2018 from [http://www.fs.usda.gov/Internet/FSE\\_DOCUMENTS/stelprdb5186110.pdf](http://www.fs.usda.gov/Internet/FSE_DOCUMENTS/stelprdb5186110.pdf)
10. *Kanon lokalnych konsultacji społecznych* (2018) Retrieved 20.01.2018 from [www.kanonkonsultacji.pl/x/985571](http://www.kanonkonsultacji.pl/x/985571).
11. Krzyżanowska, Ł. (2011). *Konsultacje społeczne Programu współpracy m.st. Warszawy z organizacjami pozarządowymi. Przykład ciekawej praktyki*. Warszawa. Retrieved 12.10.2018 from [https://partycypacjaobywatelska.pl/wp-content/uploads/2015/09/praktyka04\\_program\\_wspolpracy\\_-z\\_-ngo\\_m.st\\_warszawy.pdf](https://partycypacjaobywatelska.pl/wp-content/uploads/2015/09/praktyka04_program_wspolpracy_-z_-ngo_m.st_warszawy.pdf).
12. Kudłacz, T., Hołuj, A. (2015). *Infrastruktura w rozwoju regionalnym i lokalnym. Wybrane problem*. Warszawa: CeDeWu.
13. *Let's Talk Waste – Mornington Peninsula Community Engagement Program* (2015). Retrieved 12.10.2018 from <https://partycypacjaobywatelska.pl/strefa-wiedzy/przyklady-dzialan/transport-i-srodowisko/lets-talk-waste-mornington-peninsula-community-engagement-program/>.
14. *Let's Talk Waste – Mornington Peninsula Community Engagement Program* (2016). Retrieved 12.10.2018 from <https://participedia.net/en/cases/lets-talk-waste-mornington-peninsula-community-engagement-program>
15. Makowska, M. Konsultacje społeczne Zasad planowania lasów (The Forest Planning Rule) w USA. Przykład ciekawej praktyki, 2011 [https://partycypacjaobywatelska.pl/wp-content/uploads/2015/09/praktyka15\\_konsultacje\\_zasad\\_planowania-lasow\\_w\\_usa.pdf](https://partycypacjaobywatelska.pl/wp-content/uploads/2015/09/praktyka15_konsultacje_zasad_planowania-lasow_w_usa.pdf)
16. Maszkowska, A., Sztomp-Rutkowska, K. (eds.) (2013). *Partycypacja obywatelska – decyzje bliższe ludziom*. Białystok: Fundacja Laboratorium Badań i Działań Społecznych „SocLab”.
17. *Podstawy prawne konsultacji społecznych* (2012). Retrieved 24.10.2018 from <http://wartowiedziec.org/index.php/pracownik-samorzadowy/prawo-i-orzecznictwo/9904-podstawy-prawne-konsultacji-spoecznych>.
18. *Program ochrony środowiska przed hałasem 2018* (2018) Retrieved 12.10.2018 from <http://www.poznan.pl/mim/wos/program-ochrony-srodowiska-przed-halasem-2018,p,11105,43243.html>.
19. *Raport z konsultacji społecznych w sprawie uchwalenia Regulaminu utrzymania czystości i porządku na terenie m.st. Warszawy 16 października – 30 listopada 2017 r.* (2018). Retrieved 12.10.2018 from [http://konsultacje.um.warszawa.pl/sites/konsultacje.um.warszawa.pl/files/2017\\_konsultacje\\_raport\\_29.01.2018\\_ost.pdf](http://konsultacje.um.warszawa.pl/sites/konsultacje.um.warszawa.pl/files/2017_konsultacje_raport_29.01.2018_ost.pdf)
20. Sidor, M. (2014). *Konsultacje społeczne w największych polskich miastach: prawne aspekty – praktyczne zastosowania*. In B. Dolnicki (ed.), *Partycypacja społeczna w samorządzie terytorialnym*. Warszawa: Lex a Wolters Kluwer business.
21. *Siedem zasad konsultacji* (2013). Ministerstwo Administracji i Cyfryzacji. Retrieved 12.02.2018 from [http://archiwum.mc.gov.pl/files/7\\_zasad\\_30-04.pdf](http://archiwum.mc.gov.pl/files/7_zasad_30-04.pdf).
22. *Wyrzucić to... do właściwego kosza* (2018). Retrieved 12.10.2018 from <https://konsultacje.um.warszawa.pl/konsultacja/wyrzuc-do-wlasciwego-kosza>.
23. Zychowicz, Z. (2014). *Konsultacje społeczne w samorządzie*. Szczecin: Instytut Rozwoju Regionalnego.

## POTENTIAL OF CROWDFUNDING AS A FINANCIAL AND MARKETING INSTRUMENT IN THE REPUBLIC OF CROATIA

**Jadranka Ivankovic**

*VERN' University of Applied Sciences, Croatia  
jadranka.ivankovic@vern.hr*

**Diana Plantic Tadic**

*VERN' University of Applied Sciences, Croatia  
diana.plantic-tadic@vern.hr*

**Matea Fiser**

*VERN' University of Applied Sciences, Croatia  
mateafiser@gmail.com*

### **ABSTRACT**

*Crowdfunding could be described as a process of raising funding online. Crowdfunding works through collecting small amounts of capital from a large number of people and therefore it could be seen as an alternative way of collecting resources for financing projects, non-profit organization or private initiatives and new business ventures. At the same time crowdfunding can also be viewed as marketing instrument. In order for crowdfunding to be successful, it is crucial that idea or project are presented in a way that attracts, interests and motivates people on engagement. Successful crowdfunding campaign generates financial result and at the same time creates strong awareness, personal engagement and buying willingness of potential target audience. Current world wide practice of crowdfunding is relied on spread and reach of the internet and on the impact of social networks. First crowdfunding campaign in Croatia appeared in 2011 and its use grows ever since. But the term crowdfunding means different things to different people and still this mechanism is not very well known in general public in Croatia. The paper presents research results about understanding, knowledge, experience and future intentions about usage of crowdfunding instrument in Croatia. The research was done in 2018 by online questionnaire on which 131 people responded.*

**Keywords:** *Crowdfunding, Financial and Marketing Instrument, Innovative Entrepreneurship, Republic of Croatia*

### **1. INTRODUCTION**

Crowdfunding can be described as a process of gathering financial means through the internet. In a certain amount of time a large sum of people can donate small sums of money. The crowdfunding mechanism can also be used in any number of causes, from financing different business projects, private initiatives to starting new entrepreneurial ventures. At the same time, it can also be used as a promotional means or placement of new products. Through crowdfunding, entrepreneurs can directly present their idea to a wide population of internet users and by doing so can create a network of financing sources independent from risk capital investors, business angels or other financial institutions. This way of introducing a product or a new company enables early project ideas validation as well as a projection of a target market scope and its profitability. (Steinberg, DeMaria, 2012). Therefore, crowdfunding can be vastly applied when assessing the demand, launching a new product or service, regardless of the size or phase of a company's life cycle. According to Rajn<sup>1</sup> crowdfunding, in a wider sense, includes crowd giving, reward crowdfunding (or crowdfunding in a narrower sense), crowd lending and

---

<sup>1</sup> Rajn. Z. (2014). *Rječnik*. Croinvest.eu. Retrieved 10.07.2018. from <http://croinvest.eu/rjecnik/>

equity crowdfunding or crowd investing. Crowdfunding in a narrower sense or reward crowdfunding is an (alternative) way of securing capital for different kinds of projects, mostly in the early stages of its development, in a form of collective citizens purchase of products and/or services in a determined time-frame. It is often defined by privileged buying conditions, but also as an increase of the risk of not fulfilling the obligations. Crowd giving is an (alternative) way of securing capital that again consist of citizen purchases or donations but it is based on point-blank public interactions and group or individual assessment of projects quality, without the intent of gaining personal assets but not negating the possibility of gaining some kind of symbolical assets. Crowd investing is an (alternative) way of securing financial means in which citizens can invest money in exchange for an ownership or equity share, based on an interaction with the project launchers with the goal of making profit. Crowd lending is an (alternative) way of securing capital in which citizens lend money with or without the goal of gaining profit through interest rates. Crowd lending can't be counted as a part of crowd investing because the pledgee (lender/creditor) does not bare the risk of doing business along with the barer of the project.<sup>2</sup> Crowdfunding has been considered an alternative way of gaining financial means because the financing sources don't come from the traditional financial system. The process of gathering is transparent and is being processed in real-time. The money donated and the number of donators can be monitored for every project. Gathering the financial means is precisely time-framed and usually takes place between 30 and 60 days.<sup>3</sup> "Crowdfunding has a long and rich history with roots going back to the 1700's. The principles of micro lending reach as far back to early-1700s Ireland, where J. Swift, dubbed "the father of microcredit", founded the Irish Loan Fund. The fund provided small loans to low-income, rural families with no collateral or credit history."<sup>4</sup> Other authors have named cases of financing books releases, or war bonds as a way of gathering necessary financial means. There has also been mentioned an example of financing the stand for the Statue of Liberty in 1885. in the USA whose initiator was then the editor of The New York Times, J. Pulitzer.<sup>5</sup> In 1976, M. Yunus launched a research project in Bangladesh with the aim of providing banking opportunities to underprivileged individuals and encouraging self-employment, due to which he is credited for pioneering modern microfinancing. Within 5 years, the program had more than 30,000 members and had transformed into the Grameen Bank, which services more than 8 million borrowers today.<sup>6</sup> Among first and the most successful internet platform that allowed individuals to lend money outside the bounds of a traditional bank emerged in 2005, named Kiva. "Kiva gave lenders the opportunity to provide small loans to underprivileged individuals in developing countries with the goal of combating poverty. Since 2005, Kiva has raised a 425 million USD in crowdfunded loans with a 99% repayment rate. In 2006, in-step with this growing social momentum, fundavlog founder M. Sullivan coined the term crowdfunding."<sup>7</sup> The beginning of modern crowdfunding era can be traced back to 1997, when a British rock band funded their reunion tour through online donations from fans.<sup>8</sup> In the United States, crowdfunding gained attention when B. Camelio, a Boston musician and computer programmer, launched ArtistShare in 2003 (Freedman, Nutting, 2015, p. 1). It started as a website where musicians could seek donations from their fans to produce digital recordings, and has evolved into a fundraising platform for

---

<sup>2</sup> Ibid.

<sup>3</sup> Hafner, H. (2017). *Vodič za Crowdfunding*. Udruga za razvoj civilnog društva SMART. Rijeka. Retrieved 10.07.2018. from [http://www.civilnodrustvo-istra.hr/images/uploads/files/Crowdfunding\\_brosura2.pdf](http://www.civilnodrustvo-istra.hr/images/uploads/files/Crowdfunding_brosura2.pdf)

<sup>4</sup> *Crowdfunding History*. (2018). The Startups.co Platform. Fundable. Retrieved 10.07.2018. from <https://www.fundable.com/learn/resources/guides/crowdfunding/crowdfunding-history>

<sup>5</sup> Hafner, H. (2017). *Vodič za Crowdfunding*. Udruga za razvoj civilnog društva SMART. Rijeka. Retrieved 10.07.2018. from [http://www.civilnodrustvo-istra.hr/images/uploads/files/Crowdfunding\\_brosura2.pdf](http://www.civilnodrustvo-istra.hr/images/uploads/files/Crowdfunding_brosura2.pdf)

<sup>6</sup> *Crowdfunding History*. (2018). The Startups.co Platform. Fundable. Retrieved 10.07.2018. from <https://www.fundable.com/learn/resources/guides/crowdfunding/crowdfunding-history>

<sup>7</sup> Ibid.

<sup>8</sup> Ibid.

film/video and photography projects as well as music.<sup>9</sup> Thanks to ArtistShare's success, more rewards-based crowdfunding platforms were launched, the most prominent of which were Indiegogo in 2008 and Kickstarter in 2009. In addition to the arts, these sites host funding campaigns for social causes and entrepreneurs and small businesses (Freedman, Nutting, 2015, p. 2). Crowdfunding as a financial tool is based on micro donations. As such it offers a solution for avoiding the traditional sources such as bank loans, different types of investors or business angels. From a donors standpoint it represents a decrease in the risk they have taken by entering a business project because of the possibility to return their investments in the case of project failure. As a marketing tool crowdfunding works in two main ways. Firstly, there is the promotion of the product itself, that is being carried out through a promotional video, a thorough explanation of the project specifics and by communicating with existing and possible future donors through social networks or using internal platform communication in the form of comments and private messages. Secondly, it helps in creating the brand that will, in its core, be different from the other products made to satisfy the same need that customers have.

## 2. CROWDFUNDING INDUSTRY SIZE AND TRENDS

The statistical indicators also speak of the popularity of crowdfunding. Not only has the number of crowdfunding platforms had a steady growth over the years; there is a constant increase in the number of campaigns that are not carried out on the platforms but through internet sites of some collectives, individuals or firms. Artists, activists and entrepreneurs nowadays have over 1000 different crowdfunding platforms in the world at their disposal (Hafner, 2017, p. 10). The number of crowdfunding platforms worldwide is on the increase, and the main markets are the United States and the United Kingdom. Leading crowdfunding platforms worldwide according to the number of funding campaign in 2016 were: first Kickstarter (19.089), second Indiegogo (4.473), third Crowdfunder.co.uk (1.012), fourth Fundrazr (101) and fifth RocketHub (17).<sup>10</sup>

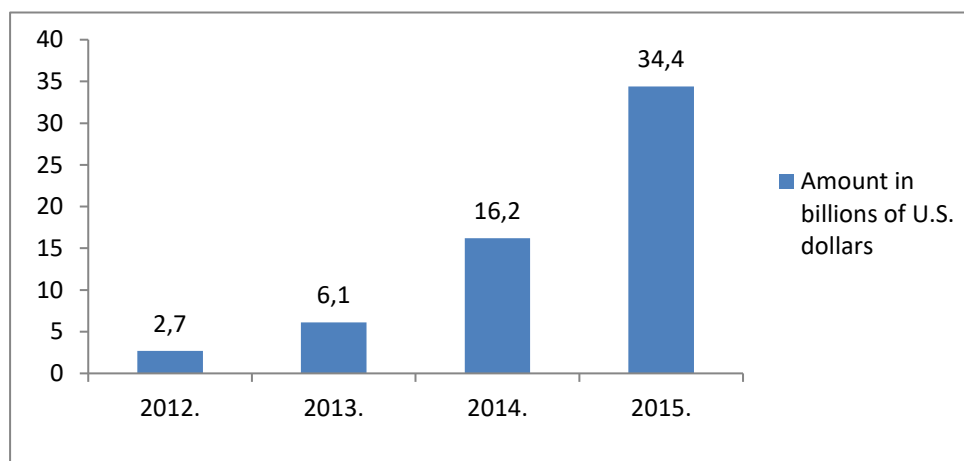

Figure 1: Crowdfunding volume worldwide from 2012 to 2015 ([www.statista.com](http://www.statista.com))

The total crowdfunding volume worldwide, (Figure 1), in 2015 (34.4 billion USD) is twice bigger than in 2014 (16.2 billion USD), with the projected grow to over 300 billion USD by 2025.<sup>11</sup> It is estimated that crowdfunding created around 270,000 jobs, and added around 65 billion USD to global economy.

<sup>9</sup> Freedman, D., M., Nutting, M., R. (2015). *A Brief History of Crowdfunding. Including Rewards, Donation, Debt, and Equity Platforms in the USA*. Retrieved 11.07.2018. from <https://www.freedman-chicago.com/ec4i/History-of-Crowdfunding.pdf>

<sup>10</sup> *Crowdfunding – Statistics & Facts*. (2017). Statista – The Statistics Portal. Retrieved 27.08.2018. from <https://www.statista.com/topics/1283/crowdfunding/>

<sup>11</sup> *Crowdfunding Statistics*. (2018). Fundly. Retrieved 10.09.2018. from <https://blog.fundly.com/crowdfunding-statistics/#general>

When it comes to regional statistics, crowdfunding revenue in North America reached 17.2 billion USD, in Asia 10.54 billion USD, in Europe 6.48 billion, in South America 85.74 million USD, in Oceania 68.8 million USD and in Africa 24.16 million USD.<sup>12</sup> From statistical data could be noticed that besides the globally biggest alternative financing mechanism of crowdfunding (34 billion USD), including other types such as peer to peer lending (25 billion USD), donations crowdfunding (5.5 billion USD) and equity crowdfunding (2.5 billion USD).<sup>13</sup> Crowdfunding started to grow, from a relatively small market of early adopters with 880 million USD reported in 2010 to 2.7 billion in 2012, 6.1 billion in 2013. It was fast forwarded to 16 billion USD crowdfunded in 2014, and reached 34 billion USD in 2015. Crowdfunding industry is doubling or more, every year, and is spread across several types of funding models including rewards, donation, equity, and debt/lending. In comparison, venture capital (VC) averages roughly 30 billion USD per year and in 2014 accounted for roughly 45 billion USD in investment, whereas angel capital averages roughly 20 billion USD per year invested.<sup>14</sup> "If equity crowdfunding doubles every year like the rest of crowdfunding has, then it could reach 36 billion USD by 2020 and surpass venture capital as the leading source of startup funding... If we look at what is driving this growth and change... we see that the collaborative economy has brought new disruptive models to giant existing industries like real estate and transportation, leveraging automation and the internet to create massively scalable businesses... It's important to understand that crowdfunding isn't a standalone funding source. Equity crowdfunding currently includes angel investors and VCs participating online as well. Rather, crowdfunding can be seen as a methodology inclusive of individual and institutional investors like VCs... A giant new capital market is taking shape before our eyes, and it is just the early days... the real winners today are the high growth entrepreneurs who have more sources and channels for finding capital than they've ever had."<sup>15</sup> While not every campaign is successful, many crowdfunding owners reach or surpass their goals. Global average success rate for crowdfunding campaigns is estimated on 50%. On average successful campaign raised about 7,000 USD, lasted 2 months, with average donation around 88 USD. Good sign to predict success of campaign is first week; campaigns that raise 30% of their goal within the first week are more likely to succeed. Age range of average campaign donor is between 24 to 35 years. Since crowdfunding is a digital fundraising method, it makes sense that younger people are more likely to give to crowdfunding campaigns. But other generous donors from different generation shouldn't be neglected; for instance baby boomers or older generations.<sup>16</sup>

## **2.1. Advantages and disadvantages of crowdfunding**

Key strengths, weaknesses, opportunities and threats of crowdfunding mechanism are presented in table 1.

*Table following on the next page*

---

<sup>12</sup> Ibid.

<sup>13</sup> Ibid.

<sup>14</sup> Barnett, C. (2015). *Trends Show Crowdfunding To Surpass VC In 2016*. Forbes. Retrieved 10.09.2018. from <https://www.forbes.com/sites/chancebarnett/2015/06/09/trends-show-crowdfunding-to-surpass-vc-in-2016/#6b40a2d54547>

<sup>15</sup> Barnett, C. (2015). *Trends Show Crowdfunding To Surpass VC In 2016*. Forbes. Retrieved 10.09.2018. from <https://www.forbes.com/sites/chancebarnett/2015/06/09/trends-show-crowdfunding-to-surpass-vc-in-2016/#6b40a2d54547>

<sup>16</sup> Ibid.

Table 4: SWOT analysis (Fišer, 2018)

Strengths (S)	Weaknesses (W)
No need for a large initial owner equity No obligation to return money to investors Possible rebooting Public presentation of ideas Research of market demand (risk reduction) Marketing and promotion mechanism	Possible frauds Public presentation of ideas Inadequate preparation of the project Inability to return investment
Opportunities (O)	Threats (T)
Global connectivity via the internet Global launch even from less developed countries Cryptocurrency and PayPal	Traditional sources of financing Insufficient public awareness of crowdfunding Market volatility

According to Steinberg and DeMaria (2012) advantages of crowdfunding compared to traditional financing are based in following; almost any venture can use it, it provides not only financing of the project, but it enables raising interest and engagement in public even before launching new product or services, provide concept testing and validity with little up-front cost, gives early insights about shopper intentions, enables building relationship with committed customers who can become product's advocates, because they are emotionally attached to the whole process and end result. Advance purchases provide working capital for financing operation and save cost of keeping goods in stock. Crowdfunding helps launch big ideas with minimum or no advance costs, whole process of raising fund could be monitored and managed by an individual from personal computer, and last but not the least, ownership of the whole project could be protected (it is not obligatory to be given away or offered as equity stake). As for the disadvantages of crowdfunding on the first place could be mentioned that it takes a different kind of preparation, (different set of knowledge), compared to traditional product pitches when starting a project. There could be a problem with the public presentation of ideas that allows them to be publically criticized and open for the competition to steal them. Another problem is possible frauds.

## 2.2. Major crowdfunding platforms

Main types of crowdfunding platforms can be distinguished by the way that firms or individuals return on investments (table 2). Donation based platforms such as GoFundMe or Crowdrise are based on "clean" donation, mostly of a smaller amount and are largely used for financing projects from a non-profit sector. Reward based platforms such as Indiegogo or Kickstarter act in a similar way, but in return for donating a certain amount it is possible to get a kind of reward, it usually being the product itself. There are also debt funding platforms, such as Zopa, based on P2P (peer-to-peer) lending and equity funding platforms, Crowdcube or Fundable in which, in return for a large sum of money invested, the investors get a small share of equity in the company. All these platforms also differ in the way that they charge for their services. Some platforms charge the flat fee, others charge during the campaign which can be executed as a deduction from the donated amount, or charged extra from the donors, or charge a commission or success fee after the project is done.



Table 2: Crowdfunding platforms – examples of different types and country or origin  
 (authors work)

Country	Platform based on		
	Donations	Reward	Debt
USA	Generosity, GoFundMe, Crowdrise, Patreon	Indiegogo, Kickstarter, Fundable	Fundable (equity)
United Kingdom		RocketHub, PledgeMusic	Zopa, Seedrs (equity) Crowdcube (equity)
Germany		Startnext	
France		Ulule	
Spain		Goteo	
Croatia	Čini pravu stvar, Doniralica, Croenergy	Croinvest	

Crowdfunding has an important characteristic of connecting projects with potential donors anywhere in the world. That means that the reason for starting a project doesn't necessarily need to be a problem in the local community but the idea can be steered towards solving a problem anywhere in the world. Wide reach and possibility range that the crowdfunding platforms provide is the reason for such interest it has evoked up until now and the estimated increase in number of campaigns and funds in the future.

### 2.3. Examples of successful crowdfunding campaigns

One of the best examples of successful crowdfunding campaigns is the one for the Pebble smart watch by Pebble Technology. The first campaign started in 2012 and by its end had gathered more than 10 million USD. It was that campaign that first had features of crowdfunding that we know today and it additionally helped its popularity.<sup>17</sup> The second campaign was based on launching new versions of the original smart watch, Pebble Time and Pebble Time Steel, under the name "Pebble Time – Awesome Smartwatch, No Compromises". As an innovation, that watch now has a planer, is waterproof, with an expected battery of 7 to 10 days, the ability of voice recording and a color e-paper display. The campaign started on 24th February 2015 and ended on 28th March 2015, with a financial goal set for 500.000 USD. By the end of the campaign they were able to get 20.338.986 USD form 78.471 investors, meaning that they have been able to achieve around 4.000% of the original goal. After the success of this campaign and smartwatch, other companies have started producing more advanced smart watches.<sup>18</sup> Pebble time also represents a good example of building a worldwide recognized brand. One of by far, most successful campaigns based on the initial financial goal is the one for the Exploding Kittens game. The game is meant for people older than 7 years and is known as one of the most fund modern card games. The campaign started under the slogan "A card game for people who are into kittens and explosions a laser beams and sometimes goats." The official start was on 20th January 2015 and it ended on 20th February 2015 on Kickstarter. In that short amount of time of only thirty days they were able not only to achieve their financial goal, but to greatly surpass it. The initial financial goal was set at 10.000 USD, but with 219.382 donors they were able to get 8.782.571 USD, surpassing their goal by more than 87.000%.<sup>19</sup>

<sup>17</sup> Hafner, H. (2017). *Vodič za Crowdfunding*. Udruga za razvoj civilnog društva SMART. Rijeka. Retrieved 10.07.2018. from [http://www.civilnodrustvo-istra.hr/images/uploads/files/Crowdfunding\\_brosura2.pdf](http://www.civilnodrustvo-istra.hr/images/uploads/files/Crowdfunding_brosura2.pdf)

<sup>18</sup> *Pebble Time - Awesome Smartwatch, No Compromises*. (2018) Kickstarter. Retrieved 31.08.2018. from <https://www.kickstarter.com/projects/getpebble/pebble-time-awesome-smartwatch-no-compromises>

<sup>19</sup> *Exploding kittens*. (2018) Kickstarter. Retrieved 31.08.2018. from <https://www.kickstarter.com/projects/elanlee/exploding-kittens>

### 3. CROWDFUNDING IN CROATIA

Crowdfunding had first arrived in Croatia in 2011 when the first successful campaign was launched. Since then until the beginning of 2018 there have been over 270 campaigns started, with 77 being successful and the total volume of financial means gathered was around 30 million HRK (more than 4.500.000 USD). 2017 was, by all available data, the most successful year gathering over 15 million HRK (around 2.250.000 USD).<sup>20</sup> Volume of crowdfunding in Croatia from 2014 to 2017 is presented in Figure 2.

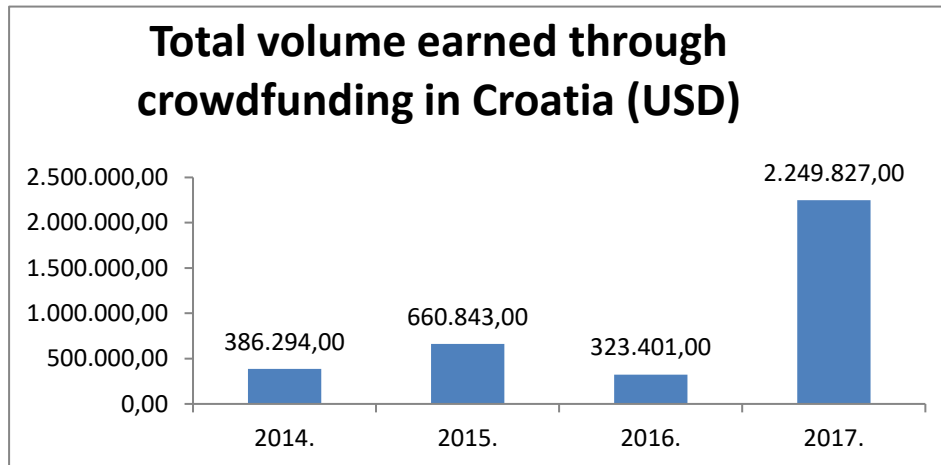

Figure 2: Crowdfunding volume in Croatia from 2014 to 2017 ([www.crowdfunding.hr](http://www.crowdfunding.hr))

Geographically speaking, most campaigns are launched from Zagreb, being the capital of Croatia. Although crowdfunding is present in most regions of Croatia, campaigns are mostly launched from bigger cities (such as Zadar, Osijek, Rijeka, Split, and so on) or in their proximity.

#### 3.1. Examples of Croatian crowdfunding campaigns

In technology sector, one of the best successes of Croatian companies through crowdfunding was Vitastiq 2. This product allows measuring the levels of vitamins and minerals in the body based on acupuncture methods and carried out by an electro-dermal method (EAV method). Afterwards the levels are uploaded to each smartphone with which Vitastiq is wirelessly connected. The campaign started on the Indiegogo platform in September 2016 with a financial goal of 29.000 USD. By the end of the campaign they have successfully raised over 193.000 USD from 1.873 donors. By enabling additional financing they have managed to gather additional 170.000 USD from over 1.200 donors. The campaign for Vitastiq 2 was the best crowdfunding campaign in 2016, and is in the top five Croatian campaigns of all time.<sup>21</sup> In the social area, two projects can be pointed out, Šapica – animal shelter and Buba bar. Šapica has, after partially finishing construction works for their new animal shelter, decided to ask for help via Indiegogo platform. The initial financial goal of 7.000 USD was achieved and doubled with the help of 265 donors.<sup>22</sup> The Bubamara association from Vinkovci started a campaign on Indiegogo under the name “Buba bar – extra chromosome for extra coffee.” They started the campaign for gathering financial means for interior decoration of the bar and hiring five people with Down syndrome.

<sup>20</sup> Hafner, H. (2018) 2017. Najuspješnija crowdfunding godina. Prikupljeno 15 milijuna kuna.

Crowdfunding.hr. Retrieved 03.09.2018. from <http://www.crowdfunding.hr/2017-crowdfunding-infografika-3771>

<sup>21</sup> Vitastiq 2 - High tech vitamin check (2018). IndieGoGo. Retrieved 03.09.2018. from <https://www.indiegogo.com/projects/vitastiq-2-high-tech-vitamin-check#/>

<sup>22</sup> Help build animal shelter. (2018). IndieGoGo. Retrieved 03.09.2018. from <https://www.indiegogo.com/projects/help-build-animal-shelter#/>

The initial goal of 10.000 USD was achieved in the first three days of the campaign. After the initial goal was achieved, a goal for additional 5.000 USD was started to hire more people with Down syndrome. By the end of the campaign they have gathered 16.821 USD from 531 donors.<sup>23</sup>

#### **4. RESEARCH**

After presenting different practice of crowdfunding in the world and in Croatia, here are exhibited some research results conducted with the primary purpose of finishing graduate thesis.<sup>24</sup> The initial assumption was that crowdfunding is still rather unknown in Croatia and by that meaning the interest for using it being poor. Croatians are only partially acquainted with the concept of crowdfunding and it is important to educate citizens about the possibilities that crowdfunding can provide.

##### **4.1. Methodology**

The research was conducted through an online poll on the social network Facebook between 28th May and 2nd June 2028, with 131 people that have participated in the research. Considering that the research was conducted based on an available sample, shown results cannot be considered as representative, but rather as indicative.

##### **4.2. Research Results**

In the sample of 131 people, 77 were women (58,8%) and 54 men (42,2%). Most of them were between the ages of 21 and 25 years (36,6%), then between 26 and 30 (24,4%) and in the age group from 31 to 35 years (15,3%). According to educational level (45%) had master degree, (32,1%) high school, (21,4%) bachelor degree and (1,5%) of respondents had lower qualification. Vast majority of respondents (87,8%) have heard for the term crowdfunding. More than half, (63%), were able to define the term crowdfunding on their own, here is one of the answers "a way to finance a company or project through a general public in which the concept is published on online platforms and the users of the platform can support them by investing financial means." Three quarter of respondents (74%) have already visited some of the internet crowdfunding platforms, (while 26% have never visited any platform). From offered crowdfunding platforms participants selected most visited platforms; on the first place was selected Kickstarter, followed by Indiegogo, Parteon and GoFundMe. When given the opportunity to name some other platforms they have visited, participants also mentioned Begslist, Hubbub, Fundly, Ulule and Sandawe. From the total number of people participating in the research 6,9% already have used a crowdfunding platform for launching their own project, while 44,3% have donated financial means. From the donors' standpoint about the advantages of crowdfunding, the participants have mentioned; ability to personally decide the amount of financial means invested, simplicity, availability, reduction of investment risk and influencing the future of the product. Among disadvantages were mentioned; possibility of frauds, unknown quality of the materials used in product, inability to see the product. As advantages from the standpoint of a company or person launching a project the participants have recognized; freedom from corporations, the feeling of satisfaction of being able to help others and a way to gauge public interest. As disadvantages they have stated; uncertainty of results, the claim that traditional marketing/promotion are more relevant for success, insufficient usage in Croatia, not sticking to deadlines for production or delivery and the threat of a project never being realized. When asked about their opinion about the future interest in using crowdfunding platforms almost half of participants (48,1%) believe that crowdfunding

---

<sup>23</sup>Buba bar – ekstra kromosom za ekstra kavu. IndieGoGo. Retrieved 03.09.2018. from <https://www.indiegogo.com/projects/buba-bar-ekstra-kromosom-za-ekstra-kavu/>

<sup>24</sup> Fišer, M. (2018). *Percepcija i stavovi o crowdfundingu kao finansijskom i marketinškom alatu*. Zagreb: Veleučilište Vern'.

platforms will be used more in the future, 24,4% believe that they will be used in the same amount as in the present. Only 8,4% of the participants believes that crowdfunding platforms will be used less in the future than they are now. The rest of the participants (19,1%) are not certain about the future usage. As the most important reasons for the increased usage of crowdfunding platforms in the future the participants have pointed out simplicity, efficiency, availability and the unused potential in countries with a lower degree of economic development, such as Croatia.

## 5. CONCLUSION

The potential of crowdfunding platforms in Croatia isn't fully recognized nor used. The main reason is relatively unknown mechanism of crowdfunding and inability of recognition of the potential of micro financing in combination with entrepreneurial opportunities that crowdfunding platforms provide. It is considered that with more start-up and small enterprises entering the market with new and innovative ideas and products the need for using crowdfunding platforms will grow. Those kinds of enterprises, new and unknown, need exposure on the market and a new approach for gathering financial means. Crowdfunding is using micro donations, as nontraditional way of financing projects. It also allows gaining insights into the demand for a certain product or services, which reduces risks of failures and make starting entrepreneurial venture less vulnerable. Crowdfunding as marketing instrument has a great potential, especially for start-ups from less developed countries who aiming worldwide business. Usage of crowdfunding platform as promotional tool is much easier, simpler and cheaper way of reaching potential users in comparison to conventional promotion through mass media. As the campaign takes place, the donors become involved in the project and through continuous updates and development of the product a new kind of customer relationship is being built. Building constant communication with the donors through the crowdfunding platforms and social networks helps maintain the transparency, building awareness and strengthen emotional connection with the new brand. Building a brand, in other words building valuable and meaningful relationship with target audience represents one of the biggest potentials for using crowdfunding as a marketing tool. In the world, as well as in Croatia, crowdfunding is a good method for launching projects because it allows entrepreneurs access not only to domestic but also to foreign investors and markets. For investors crowdfunding platforms represent the opportunity to affect the future of certain products, reduce investment risks and gain access to products not usually available in their market.

## LITERATURE:

1. Barnett, C. (2015). *Trends Show Crowdfunding To Surpass VC In 2016*. Forbes. Retrieved 10.09.2018. from <https://www.forbes.com/sites/chancebarnett/2015/06/09/trends-show-crowdfunding-to-surpass-vc-in-2016/#6b40a2d54547>
2. *Buba bar – ekstra kromosom za ekstra kavu*. (2018). IndieGoGo. Retrieved 03.09.2018. from <https://www.indiegogo.com/projects/buba-bar-ekstra-kromosom-za-ekstra-kavu#/>
3. *Crowdfunding History*. (2018). The Startups.co Platform. Fundable. Retrieved 10.07.2018. from <https://www.fundable.com/learn/resources/guides/crowdfunding/crowdfunding-history>
4. *Crowdfunding – Statistics & Facts*. (2017). Statista – The Statistics Portal. Retrieved 27.08.2018. from <https://www.statista.com/topics/1283/crowdfunding/>
5. *Crowdfunding Statistics*. (2018). Fundly. Retrieved 10.09.2018. from <https://blog.fundly.com/crowdfunding-statistics/#general>
6. *Exploding kittens*. (2018) Kickstarter. Retrieved 31.08.2018. from <https://www.kickstarter.com/projects/elanlee/exploding-kittens>

7. Fišer, M. (2018). *Percepcija i stavovi o crowdfundingu kao financijskom i marketinškom alatu*. Zagreb: Veleučilište Vern'.
8. Freedman, D., M., Nutting, M., R. (2015). *A Brief History of Crowdfunding. Including Rewards, Donation, Debt, and Equity Platforms in the USA*. Retrieved 11.07.2018. from <https://www.freedman-chicago.com/ec4i/History-of-Crowdfunding.pdf>
9. Hafner, H. (2017). *Vodič za Crowdfunding*. Udruga za razvoj civilnog društva SMART. Rijeka. Retrieved 10.07.2018. from [http://www.civilnodrustvo-istra.hr/images/uploads/files/Crowdfunding\\_brosura2.pdf](http://www.civilnodrustvo-istra.hr/images/uploads/files/Crowdfunding_brosura2.pdf)
10. Hafner, H. (2018) *2017. Najuspješnija crowdfunding godina. Prikupljeno 15 milijuna kuna*. Crowdfunding.hr. Retrieved 03.09.2018. from <http://www.crowdfunding.hr/2017-crowdfunding-infografika-3771>
11. *Help build animal shelter*. (2018). IndieGoGo. Retrieved 03.09.2018. from <https://www.indiegogo.com/projects/help-build-animal-shelter#/>
12. *Pebble Time - Awesome Smartwatch, No Compromises*. (2018) Kickstarter. Retrieved 31.08.2018. from <https://www.kickstarter.com/projects/getpebble/pebble-time-awesome-smartwatch-no-compromises>
13. Rajn. Z. (2014). *Rječnik*. Croinvest.eu. Retrieved 10.07.2018. from <http://croinvest.eu/rjecnik/>
14. Steinberg, S., DeMaria, R. (2012). *The Crowdfunding Bible: How to Raise Money for Any Startup, Video Game or Project*. ReadMe. Retrieved 27.08.2018. from <http://www.crowdfundingguides.com/The%20Crowdfunding%20Bible.pdf>
15. *Vitastiq 2 - High tech vitamin check* (2018). IndieGoGo. Retrieved 03.09.2018. from <https://www.indiegogo.com/projects/vitastiq-2-high-tech-vitamin-check#/>

## INVESTIGATING CONSUMERS' BRANDS CONNECTION ON FACEBOOK

**Ivana Bilic**

*University of Split, Faculty of Economics, business and Tourism, Croatia  
ibilic@efst.hr*

**Milena Jelic Dzepina**

*Solar Projekt d.o.o., Croatia  
milenajelic87@gmail.com*

**Ana Cuic Tankovic**

*University of Rijeka, Faculty of Tourism and Hospitality Management, Croatia  
anact@fthm.hr*

### ABSTRACT

*Due to the fact that social networks have become an irreplaceable part of modern life, their effectiveness for business purposes is increasing, too. The development of social networks and the growing number of users have a strong impact on companies' attempt to improve the communication with their fans and/or followers. Social networks are recognized as a popular and widely used marketing tool hence they present different information about the product and the brand to various market segments. Specifically for these media, every contact with the brand via social network does not necessarily mean that the user is also an actual or a potential buyer. Taking into account the dominance of Facebook usage among others social networks in Croatia, this paper aims to understand the primary motives driving the Facebook users to be connected with the brand. The research methodology includes a questionnaire-based study on a sample of 207 Facebook users. The results point out that the main motivation attribute is to have real-time information about product and events related to the product. In addition, some study observations show that there is a significant statistical positive correlation between benefits of being informed of competition and social interactions and information as motive, as well as the respondents' engagement in social networks positively affects self-esteem.*

**Keywords:** *brand connection, Facebook users, motivation, community management, social networks*

### 1. INTRODUCTION

Social networks are a group of online applications based on the ideological and technological foundations of web 2.0, which enable the creation and exchange of user content and provide technology platform for connecting users, producing and sharing content (Chu, 2011). Growth and availability of social networks has resulted that has become an essential item in every individual's life, either for business or private purposes (Cvijik & Michaelles, 2012). Consumers are turning more and more into virtual communities to share opinions and information with other social network users or address the business directly. Simplicity in the exchange of information have great importance to companies as this can build a better relationship with consumers (Chu, 2011). Making a purchase or sale decision, social networks are first consulted with other users of that product, or see how many fans have a particular product, and then make a conclusion about purchase of it. The latest survey shows that Facebook has more than 2.13 billion users (newsroom.fb.com/company info, 29<sup>th</sup> March 2018) and is considered to be the most attractive marketing network (Cvijik & Michaelles, 2012). The purpose of Facebook's site is to connect people with similar interests and to facilitate communication (Wei Ho, 2014). Consumers are associated with brand communities because they like it and feel loyal to it, and

by connecting through social networks loyalty can be further strengthened (Gummerus et al., 2012). Engagement with Facebook fan page has positive effects on consumers' brand awareness, word-of-mouth activities and buying intention (Heutter et al., 2013). After connecting with brand, users thinking about brand has improved and Facebook page of company has more positive image (Coelho et al., 2015). The number of attracted and retained consumers is a key indicator for assessing the success of Facebook advertising, and in that way it is important to investigate the motive for connecting one of the users to that site so that each user of the community would benefit (Field & Sharp, 2012). Therefore, the reason why customers connect to some brand through Facebook need to be further explore. In this way, the company is aimed to find a reason that has put consumers to connect with that brand and to attach importance to only real or potential consumers. The problem that may arise is that users can transfer product information that is not true at all, and on the other hand, the company can give them importance and then take into account their opinion, without being the actual buyers. It is assumed that buyers connect with some brands because they like this product and what they would like to buy, but it is not sure that they are buying it or being potential consumers. This paper explores the factors that motivate users to connect with a brand, that is, to join to a brand community on Facebook. This connection will allow the firms to collect product and business tips, while other users, through comments and number of fans, might have a better picture of the product, and thus make it easier to decide on purchasing.

## **2. LITERATURE REVIEW**

The purpose of Facebook's site is to connect people with similar interests and to facilitate communication (Wei Ho, 2014). Consumers are associated with brand communities because they like it and feel loyal to it, and by connecting through social networks loyalty can be further strengthened (Gummerus et. al., 2012). Engagement with Facebook fan page has positive effects on consumers' brand awareness, word-of-mouth activities and buying intention (Heutter et al., 2013). After connecting with brand, users thinking about brand has improved and Facebook page of company has more positive image (Coelho et al., 2015).

### **2.1. The brand community**

The brand community is a specialized group of individuals who, with the help of social networks, are linked to a particular brand, regardless of where are they located (Gummerus et al., 2012). It allows consumers to share information about a particular product, share opinions and experiences with consumers, and that helps companies to easily establish contact with consumers so they can adapt more quickly to the market and its needs (Jayasingh & Venkatesh, 2015). Companies enter into dialogue with consumers and as such, they are increasingly attracted to digital interactivity through social networks (Olczak & Sobczyk, 2013). More businesses are operating on network communities for advertising, consumer involvement in product development and improvement, observation and analysis of user-generated content, building consumer relationship, feedback from consumer, and for the strengthening of the brand (Cvijik & Michaelles, 2013; Gummerus et al., 2012). The reason for great popularity of social media among companies is because of the speed of spreading reliable information over the Internet because they have far greater speed than television, radio, magazines, and other media (Schivinski & Dabrowski, 2013). One of the reasons for advertising through social networks is that it is a cheaper way of advertising than other media, which allows them to attract more advertising for less money. Consumers find that more advertised products are at the same time higher quality products (Schivinski, 2013). The greatest importance attaches to the development of consumer relationship, not just for giving information (Jayasingh & Venkatesh, 2015).

Companies aim to attract the attention of users, encourage them to connect with their brand and convince them to look at the content of the site (Luarn & Chiu, 2015), but to attract these users it is essential for companies to draw up an online user access plan (Cvijik & Michaelles, 2012).

## **2.2. Customer brand engagement**

The consumer engagement is defined as ways consumers engage with brands through social media, or participate in online environments (Jayasingh & Venkatesh, 2015). Customer engagement plays a key role in trusting users and word-of-mouth activities through social networks (Islam & Rahman, 2015). Consumers participate in different types of behaviour on social networks, such as assisting other users or sharing experiences with them, while there are consumers who just read comments without engaging in a conversation, which does not mean that they are not users of that inside or not (Gummerus et. al., 2012). Nevertheless, the key thing is for both parties to have some benefit that interaction between the company and the consumer results in substantial information for both sides (Gummerus et. al., 2012). Everyday use of social media has created a need for consumer engagement, which in social media has become particularly important as it enables firms to reach them more easily and to communicate with them (Jayasingh & Wenkatesh, 2015; Gummerus et. al., 2012). Another fact that contributes to greater consumer engagement it's the proven consumers' positive attitude towards social networking (Chu, 2011) The key determinants of consumer engagement are related to the content and the timeliness of brand pages, not the number of consumers associated with that brand (Jayasingh & Wenkatesh, 2015).

## **3. HYPOTHESES DEVELOPMENT**

Facebook has enabled companies to open a page where they will share all the information they have about their product, and by connecting the users themselves to their site, it enables two-way communication between the company and the consumer. The company that actively share information on its Facebook page aims to get as much feedback as possible through interaction with users (Chu, 2011). The opportunity to share their suggestions and possible product defects with the companies. Their opinion should be respected or will be explained why it has not been recognized but will be of great importance to the user and will gain greater confidence in the brand. Therefore, companies should keep track of the actions taken by the user and monitor the interests of the user's brand community (Cvijik & Michaelles, 2013). In order to investigate whether the improvement of the existing and the development of new products is one of the reasons for linking the consumer with the brand, the authors predict as follows:

- H1: Users are positively motivated to connect with brands on Facebook in order to enhance the existing products.
- H2: Users are positively motivated to connect with brands on Facebook in order to participate in developing new products.

Brand information is shared in the form of posts appearing in the middle of the page, and users who have linked to that brand can see every new information related to that brand. It is considered that any activity that user makes with that information (by sharing, commenting) means that information has been successfully accessed to the consumer (Luarn & Chiu, 2015). The activity made by a user who is a member of a community brand is considered valuable, while the activity made by a user who is not a member of this community has not a great significance (Cvijik & Michaelles, 2013). Most users use the brand page as a source of information, even though they do not comment on them or give them "like" (Gumerus et al., 2012).



Users are more interested in the brand than sharing opinions, while users are seeking advice and thinking in decision-making, they want to gather more information about an event or brand, as they gain a sense of security (Bejtagić-Makić, 2013). As such, this hypothesis is tested:

- H3: Users are positively motivated to connect with brands on Facebook in order to gain better information.

Providing exclusive offers and discounts to members who link to the brand is an incentive for other users to join the community (Jayasingh & Venkatesh, 2015). Every reward for a member of the community has a time limit, and after some time it is no longer interesting (Cvijik & Michaelles, 2013). The party entertainment in the community is more important than acquainting other members of the community, and with that these activities should increase customer satisfaction and loyalty (Gumerus *et al.*, 2012). Starting from the point that rewarding users who have linked to the brand contribute to a greater engagement of the user, the third hypothesis is set as:

- H4: Users are positively motivated to connect with brands on Facebook for making benefits.

The information displayed in a user's profile is affecting self-confidence, especially when users take care of the look of their profile. Those users who do not care about the look of their profile are likely to even lower their self-confidence (Gonzales & Hancock, 2011). In this way, users who have a low level of confidence will more closely associate with brands because it is possible to increase their confidence. The trademark connectivity has an effect on growth or decline in confidence as each social networking partner informs their social network friends also display information on their profile, too. Hence, the fourth hypothesis is as follows:

- H5: Connecting with the brand on Facebook has a positive influence on users' self-confidence.

Social networks have become known as a means of self-presentation (Choi & Kim, 2014). Every brand link is visible on Facebook's page, which means that other affiliated users can see its activity (Jayasingh & Venkatesh, 2015). Consumers that are concerned about the opinions of family, friends, and other users about the quality of the brand think what brand they associate with (Schivinski, 2013). In this paper, we want to investigate whether there are users who want to link to the brand just to see other users see this information, or they are actually the actual users of that niche. Luxury brands are one of the examples of products that affect better self-representation. Such brands are considered products that bring prestige, regardless of their functionality and benefit the user has of such products (Dhaoui, 2014). The reason for connecting with such brand users is self-expression, self-build, recognition, and recognition by other users of social networks (Bejtagić-Makić, 2013). Self-reporting is an important part of developing relationships that are often used in social networks, especially on social networks like Facebook (Gumerus *et al.*, 2012). Self-presentation serves as the main means by which a user can influence the perception of other people about themselves (Choi & Kim, 2014). Consumers usually use assets and brands to build their image in society (Smith & Fisher, 2012) while social network users use self-presentation as a means of self-representation (Choi & Kim, 2014). Hence:

- H6: Connecting with a brand on Facebook has a positive influence on a users' better picture of themselves.

#### **4. METHODOLOGY**

For the purpose to explore the previously advanced connections and to test the hypotheses, a primary research has been conducted. The social network used was Facebook because it is the most visited social network in Croatia (newsroom.fb.com/company info, 29<sup>th</sup> March 2018) and because it allows the interaction with the customers (Chu, 2011). The questionnaire is designed

according to the related academic papers (Schivinski & Dabrowski, 2013; Park et al., 2009; Diffley et al., 2011; Gonzales & Hancock, 2011) and adapted to the novelty of the research. The first part of the questionnaire aimed to collect some general information about their engagement with Facebook. In the second part the participants were asked about subjective answers regarding their personal perceptions of themselves, while the third section addressed the participants' motivation to be connected with some brands. The first three sections were composed with questions measured using a five-point Likert scale, ranging from 1-“strongly disagree” to 5-“strongly agree”. In the final part of the questionnaire the respondents answered about their demographic characteristics. The questionnaire was conducted in February and March 2014 via Facebook and direct mail for active Facebook users who were asked to participate on a voluntary basis. Finally, a total of 207 fully completed questionnaires were collected.

## 5. RESULTS

### 5.1. Sample profile

The descriptive profile of the respondents' is presented in Table 1. The results indicate a higher per cent of female respondents (67%) than male participants, where the majority are younger than 34 years (67.6%) with the mobile internet access (87%), all from Croatia (100%).

*Table 1: Sample characteristics (research results)*

Measure and item		Percent
Gender	Female	67
	Male	33
Age	<18	4.8
	18-24	29
	25-34	38.6
	35-44	23.2
	45>	4.45
Employment status	Employed	51.2
	Students	28.5
	Unemployed	16.9
	Retired	1.4
Average daily time spent on Facebook	< 10 minutes	8.7
	10-30 minutes	21.3
	31-60 minutes	14.5
	1-2 hours	27.1
	2-3 hours	16.4
	>3 hours	12.1
Mobile internet access	Yes	87.3
	No	12.3

According to the intensity of the usage of Facebook, the respondents answered about their worries and negative sides of connecting to a brand (Table 2). The majority of Facebook users identify themselves as a very active user (40.6%), followed by a moderate user (26.1%) and extremely active user (24.2%). There is a statistically significant correlation between the intensity of Facebook users and “I’m worried if this information will appear on my profile” ( $r=0.192$ ;  $p=0.007$ ) and “It matter to me if my friends like this brand, too” ( $r=0.147$ ;  $p=0.049$ ).

Table 2: Intensity of Facebook activities and attitudes toward negativities of brand connection (research results)

Item	Are you an active Facebook user?				
	Not at all	Slightly	Moderately	Very	Extremely
<b>I'm worried if this information will appear on my profile</b> ( $X^2= 16.894$ ; $p < 0.05$ )					
Strongly disagree	3.1%	1.0%	9.7%	7.7%	5.1%
Disagree	0.5%	0.0%	4.6%	10.2%	3.1%
Neither agree nor disagree	1.5%	1.0%	7.1%	11.7%	8.2%
Agree	1.0%	0.5%	4.1%	8.7%	7.1%
Strongly agree	0.0%	0.0%	0.5%	2.6%	1.0%
<b>I'm worried whether my friends will notice that brand</b> ( $X^2= 16.817$ ; $p > 0.05$ )					
Strongly disagree	2.5%	1.5%	9.1%	13.2%	6.1%
Disagree	2.0%	0.0%	8.1%	10.7%	6.1%
Neither agree nor disagree	0.0%	0.0%	6.6%	13.2%	9.6%
Agree	1.5%	0.0%	2.0%	4.1%	2.0%
Strongly agree	0.0%	0.0%	0.0%	0.0%	0.5%
<b>It matters to me if my friends like this brand, too</b> ( $X^2= 17.654$ ; $p < 0.05$ )					
Strongly disagree	3.1%	1.0%	8.7%	16.3%	6.6%
Disagree	1.5%	0.5%	10.2%	11.7%	5.6%
Neither agree nor disagree	0.5%	1.0%	6.1%	10.7%	8.7%
Agree	1.0%	0.0%	0.5%	1.5%	3.1%
Strongly agree	0.0%	0.0%	0.0%	1.0%	0.5%

## 5.2. Mean ranking and hypotheses testing

The respondents have the possibility to express the intensity of the motives that are moving them to connect to a brand on Facebook. As shown in Table 3, the motivator with the heights mean is Information (3,82), followed by Searching for new products (3,52). The least important factor which motivate the followers of a brand is Self-expression (2,65).

Table 3: Motivators' mean ranking (research results)

Rank	Motivators	Mean	SD	Mode
1	Information	3.82	0.923	4
2	Searching for new products	3.52	1.199	4
3	Fun and entertainment	3.47	1.046	4
4	Free time	3.27	1.123	4
5	Social interaction	2.89	1.107	3
6	Professional advancement	2.85	1.205	4
7	Self-expression	2.65	1.099	3

All the hypotheses are tested with Pearson correlation test in order to investigate the statistically significant positive correlation between the constructs.

Table 4: Hypotheses testing with Pearson correlation test

Hypotheses		r	p	Conclusion
1	Users are positively motivated to connect with brands on Facebook in order to enhance the existing products	0.203	0.007	Hypothesis accepted*
2	Users are positively motivated to connect with brands on Facebook in order to participate in developing new products	0.253	0.001	Hypothesis accepted*
3	Users are positively motivated to connect with brands on Facebook in order to gain better information	0.460	0.000	Hypothesis accepted*
4	Users are positively motivated to connect with brands on Facebook for making benefits	0.448	0.000	Hypothesis accepted*
5	Connecting with the brand on Facebook has a positive influence on users' self-confidence	0.219	0.018	Hypothesis accepted**
6	Connecting with a brand on Facebook has a positive influence on a users' better picture of themselves	0.260	0.004	Hypothesis accepted*

\*at the level  $p < 0.01$

\*\*at the level  $p < 0.05$

The results of the Pearson correlation test indicate that all the hypotheses are accepted at the level of  $p < 0.01$ , except for one “Connecting with the brand on Facebook has a positive influence on users’ self-confidence” at the level of  $p < 0.05$ . Therefore, a statistically significant positive correlation is found in the motives to connected to a brand on Facebook for participating in enhancement of existing products and developing new products, as well as making benefits. The strongest connection and motivation for connecting with a brand on Facebook is in order to Seek new information (H4).

## 6. CONCLUSION

The attempt to improve the communication between the customers and the company has result in growing activities on the social networks, which allows any user to be able to reach information at any time and in a short period of time. Also, users often share all product news with their friends so the company receive more attention without additional efforts. Social network users are usually connected with a brand for a various kind of motives: this paper investigated what lead the users to be connected with a brand and which positive impact it has on their self-esteem and better picture of themselves. The survey found that respondents are highly motivated to connect with the brand firstly to gain information and secondly to search for new products. Research has shown that users the users that are connected to a brand are also those who want to participate in designing and improving products. In this way, users feel that their thinking is important and they are not just passive observers. Manufacturers are aware that they will increase the number of users by rewarding those who recommend them to others. Inclusion in the social network has a positive impact on self-esteem because it feels equally valuable to other users on the social network as it is associated with brands like the rest. This research has identified a group of users looking for information on new products, and their motive is self-presentation. By linking to a brand on Facebook, the user builds a positive image of himself and decides how to present himself. These research results present an important starting point for marketers and brand managers because it allows them to understand their social media followers. Further researches will have the possibility to compare the results with the attitudes and motives of the respondents from other countries, because one of the limitation of the study is the fact that the questionnaire was conducted only in Croatia. Also, with the greater interest of some other social networks like Pinterest and Instagram, it will be interesting to investigate the motivation to connect to a brand if the social network is different from the one researched in this paper, Facebook.

According to the big number of present brands on Facebook, it will be useful to conduct a similar research with the differentiation of products' type. Given the limited nature of the research in this field, the provided results should be viewed as a valuable insight in understanding the Facebook users who are connected to popular brands on the social network.

#### LITERATURE:

1. Beitagic-Makic M., Duman T. (2013), *Key Motivational Drivers for Customer Engagement on Facebook Brand Fan Pages in Bosnia & Herzegovina*, International Conference on Economic and Social Studies, Vol. 10 No. 11, pp. 1-9.
2. Choi J., Kim Y. (2014), *The moderating effects of gender and number of friends on the relationship between self – presentation and brand – related word-of-mouth on Facebook*, Personality and Individual Differences, Vol. 68, pp. 1-5.
3. Chu S.C. (2011), *Viral advertising in social media: participation in Facebook groups and responses among college - aged users*, Journal of Interactive Advertising, Vol. 12 No. 1, pp. 30-43.
4. Coelho J., Nobre H., Becker K. (2014), *The impact of Facebook presence on brand image*, International Journal of Technology Marketing, Vol. 9 No. 3, pp. 320-332.
5. Cvijikj I.P., Michahelles F. (2012) *Understanding Social Media Marketing: A case Study on Topics, Categories and Sentiment on a Facebook Brand Page*, Information Management, pp. 175-182, ETH Zurich
6. Cvijikj I.P., Michahelles F. (2013) *Online engagement factors on Facebook brand pages*, Social Network Analysis and Mining, Vol. 3 No. 4, pp. 843-861.
7. Dhaoui C. (2014), *An empirical study of luxury brand marketing effectiveness and its impact on consumer engagement on Facebook*, Journal of Global Fashion Marketing, Vol. 5 No. 3, pp. 209-222.
8. Diffley, S., Kearns, J., Benneti, W., Kawalek, P. (2011), *Consumer Behaviour in Social Networking Sites: Implications for Marketers*, Irish Journal of Management, pp. 47-65.
9. Gonzales, A. L., Hancock, J. T. (2011), *Mirror, Mirror on my Facebook Wall: Effects of Exposure to Facebook on Self-Esteem*, Cyberpsychology, Behavior and Social Networking, Vol. 14 No. 1-2, pp. 79-83.
10. Gummerus J., Liljander V., Weman E., Pihlstrom M., (2012), *Customer engagement in a Facebook brand community*, Management Research Review. Vol. 35 No.9, pp. 857-877.
11. Ho C.W. (2014), *Consumer behavior on Facebook: Does consumer participation bring positive consumer evaluation of the brand*, EuroMed Journal of Business, Vol. 9 No.3, pp. 252-267.
12. Hutter K., Hautz J., Drenthard S., Fuller J. (2013), *The impact of user interactions in social media on brand awareness and purchase intention: The case of MINI on Facebook*, Journal of Product & Brand Management, Vol. 22 No. 5/6, 342-351.
13. Islam J., Rahman Z. (2015), *Linking Customer Engagement to Trust and Word – of - Mouth on Facebook Brand Communities: An Empirical Study*, Journal of Internet Commerce, Vol. 15 No. 1, pp. 40-58.
14. Jayasingh S., Venkatesh R. (2015), *Customer Engagement Factors in Facebook Brand Pages*, Asian Social Science, Vol. 11 No. 26, pp. 19-29.
15. Luarn P., Lin Y.F., Chiu Y.P. (2015), *Influence of Facebook brand-page posts on online engagement*, Online Information Review, Vol. 39 No. 4, pp. 505-519.
16. Nelson-Field K., Sharp B., Riebe E. (2012) *What`s Not to "Like"? Can a Facebook Fan Base Give a Brand The Advertising Reach It Needs?*, Journal of Advertising Research, Vol. 52 No. 2, pp. 262-269.

17. Olczak A.B., Sobczyk R.K. (2013), *Brand Engagement on Facebook based on Mobile Phone Operators, Activity Within Four European Countries*, *Studia Ekonomiczne*, Vol. 150, pp. 97-108.
18. Park, N., Kee, K.F., Valenzuela S., (2009): *Being Immersed in –social Networking Environment: Facebook Groups, Uses and Gratifications, and Social Outcomes*, *Cyber Psychology & Behavior*, Vol. 12 No. 6, pp. 729-733.
19. Schivinski B., Dabrowski D. (2013), *The impact of Brand Communication on Brand Equity Dimensions and on Brand Purchase Intention Through Facebook*, GUT FME Working Paper Series A. Gdansk (Poland): Gdansk University of Technology, Faculty of Management and Economics, Vol. 4 No. 4, pp. 1-24.
20. Smith A., Fischer E. (2012), *How Does Brand-related User-generated Content Differ across YouTube, Facebook, and Twitter?*, *Journal of Interactive Marketing*, Vol. 26 No. 2, pp. 102-113.

## CLASSIFICATION OF R&D ACTIVITY COSTS IN FINANCIAL ACCOUNTING

**Anna Dyhdalewicz**

*Bialystok University of Technology, Poland*  
*a.dyhdalewicz@pb.edu.pl*

### **ABSTRACT**

*The aim of the article is to show the way classification of research and development activity determines the expression of research and development work from the perspective of financial accounting. The article has made use of: the method of analysis utilized during the review of subject related literature, a comparison analysis applied to contrast national balance sheet regulations contained within the Polish Accounting Act as well as in the International Accounting Standard 38, observation of economic practice and the deduction and synthesis method utilized to formulate final conclusions. From the perspective of balance sheet law the initiation of the innovation process requires that the enterprise separate research work from development work. The classification of conducted work as well as the assessment of their results becomes a key issue. Classification of work in the framework of R & D activity due to the technical and production criterion was adopted as binding in the balance sheet law, thus determining the principles of recognizing costs under the financial accounting. Research costs are incurred at the stage prior to development phase. From the Polish Accounting Act and IAS 38 point of view it is possible to capitalize only the costs of development work after specified conditions have been met. In the practice of various countries lack of a uniformed approach to R&D cost in accounting laws make it difficult to compare financial statements depending on the type of business activity and to assess the sources of innovation. Many entities discern only the aspect of product and technological innovation of production.*

**Keywords:** *Financial accounting, Research and development activity, Research and development activity classification, research costs, development costs, Polish Accounting Act, IAS 38*

### **1. INTRODUCTION**

The aim of the article is to show the way classification of research and development activity determines the expression of research and development work from the perspective of financial accounting. To reach this goal it was necessary to present:

1. the essence of and selected classifications of research and development activity,
2. ways of recognizing costs of research and development work in general financial reports with consideration for classification of that work as part of R&D activity according to the technical and production criterion,
3. recognition of research and development work costs in light of regulations contained within the Accounting Act currently in force in Poland, in accounting law as well as in the directives of the International Accounting Standard 38 intangible assets (IAS38) and the assessment of their usefulness.

The article has made use of: the method of analysis utilized during the review of subject related literature, a comparison analysis applied to contrast national balance sheet regulations contained within the Polish Accounting Act as well as in the International Accounting Standard 38, observation of economic practice and the deduction and synthesis method utilized to formulate final conclusions.

## 2. THE ESSENCE AND SELECTED CLASSIFICATIONS OF RESEARCH AND DEVELOPMENT ACTIVITY

More and more often economic entities stress the importance of innovation which results in growing engagement into research and development as well as allocation of relatively high financial resources to carry out this activity. Spending for research and development is part of outlays made toward innovative activity and the innovations themselves encompass a number of pursuits which far exceed the scope of typical research and development activity realized as part of implementation work and the later commercialization of the new products or technologies. The result of research and development is the creation of a new situation most often concerning a new and improved product (product innovations) as well as the process of its production (process innovations) (Knosala, Boratyńska-Sala, Jurczuk-Bunkowska, Moczala, 2014, p. 221; Gabrusewicz, 2017, pp. 436-437). For the most part this work is conducted by the enterprise's own research and development department. Having an internal R&D department both adds significant value to and comprises a strategic asset of an enterprise. Nevertheless, the development of technology, widespread globalization of business, social and economic transformations as well as the popularization of the Internet have contributed to the unrestricted communication between entities operating within modern economy. In the open innovation model R & D activity is realized in cooperation with scientific entities as well as within a network of cooperating enterprises and their R&D centers and aimed at better utilization of shared potential (Stanisławski, Szymański, Trębska, 2018, p. 30). According OECD research and development activity is a creative, systematic pursuit meant to expand the stock knowledge (including knowledge of humankind, culture and society) and encompassing scientific research and developmental work as well as the utilization of knowledge resources to create new applications. Such activities must be: innovative, creative, unpredictable, methodical, transferable or reproducible (Podręcznik Frascati 2015, p. 49; Świadek, 2017, p. 77; Piersiala, 2014, p. 302). This activity does not include education and training, purchase of tangible and intangible assets, the initiation of new production, marketing of new or improved products, administration and supportive activity. This definition is used to collect data on financial and human resources for research and development. In addition, it appears - sometimes in a modified form - in legislation and executive acts on taxation and other types of financial support in some countries. In the light of Frascati Manual, the term "research and development" (R & D) covers three types of R & D: basic research, applied research and development (see Table 1).

*Table 1: Types of R & D in the light of Frascati Manual (developed by the author on the basis of: Podręcznik Frascati, 2015, p. 49)*

Types of R&D	Description
Basic research	experimental or theoretical work undertaken primarily to acquire new knowledge about the basics of phenomena and observable facts, without focusing on specific application or use.
Applied research	the original research undertaken to acquire new knowledge. However, they are primarily focused on a concrete, practical goal.
Development works	undertaken in a methodical manner, based on knowledge acquired as a result of research and development activities and practical experience as well as generating additional knowledge, directed at creating new products or processes or at improving existing products or processes.

On account of its complexity work which comprises research and development activity varies immensely. Figure 1 presents the scope of research and development according to Polish Act on rules of financing science and tax laws on PIT and CIT. Tax regulations in force in Poland today allow the deduction from the taxation base a predetermined percentage of costs for



research and development activity. The right to take advantage of this deduction is not connected with having to achieve a particular effect of realized activities or work. To be able to employ the B&R deduction requires:

- a determination of the type of activities being realized as part of the enterprise's operations and their qualification from the perspective of the legal definition of research and development activity,
- precise identification of those costs which may be qualified as eligible for deduction costs (the law maker defines their precise categories),
- isolation of those costs in accounting ledgers.

In practice in many cases proving that the initiated activity fulfills the definition of B&R activity demands obtaining an expert opinion or an individual interpretation of accounting law regulations. The incentive of paying lower income taxes is supposed to encourage entrepreneurs to initiate new investment with resources which were thus saved.

*Figure 1: The scope of research and development according to Polish Act on rules of financing science and tax laws on PIT and CIT (developed by the author)*

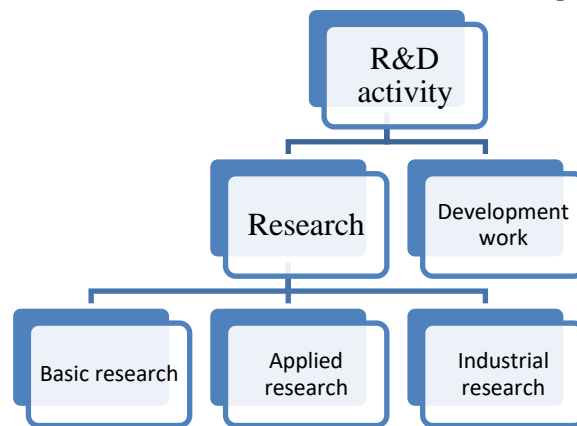

Taking into account the criterion of functionality it is possible to distinguish the following types of R&D activity (Szczepaniak, 2016, p. 31; Wsparcie działalności B+R i nowych inwestycji, 2018, pp. 12-13):

- basic research is understood as original research work, experimental or theoretical, undertaken to gain new knowledge that is not meant to be employed in a particular application or use, such as the discovery of new scientific laws or theories, usually conducted by external scientific institutes or universities,
- applied research is research that attempts to convert general theories and scientific laws into specific and practical uses, is carried out by research institutes as well as R&D departments included within the structure of the enterprise,
- industrial research is research whose goal is to gain new knowledge and abilities which can be used to develop new or introduce significant improvement of existing products, processes or services and involve the creation of elements of more complex systems, construction of prototypes in a laboratory environment or simulation of existing systems,
- development work is a systematically carried out work that is based on knowledge obtained as a result of research, closely connected with the development of new or improved technologies, prototypes of new products, their testing, preparation of technical documentation, development of a functioning model of a new product and may directly result in applying for patents.

Table 2 presents classifications of R&D activity using criteria other than the criterion of technology and production.

*Table 2: Classification of R&D activity developed using its connections to business and for management purposes (developed by the author on the basis of: Knosla, Boratyńska-Sala, Jurczyk-Bunkowska, Moczala, 2014, pp. 222-223; Rokita, 2014, p. 206; Świadek, 2017, p. 81)*

Criterion	Type of R&D activity	Aim
Connection of R&D to business	R&D for existing business	To maintain the current position of the enterprise
	R&D for new business	To identify new market opportunities
	R&D for preliminary research	To gather knowledge within various fields which will be important in the future
For management purposes	Profit related	To use available knowledge to improve existing processes or products, short realization period
	Radical	Practical approach where successful implementation provides benefits of increased theoretical as well as practical knowledge, medium realization period, costly, significant risk of failure
	Fundamental	As a rule increase theoretical knowledge, long realization period, significant risk of failure

However, according to S. Rokita no single approach to the classification of research and development work which would satisfy the extremely varied informational needs has been developed. Currently the recognition of basic, applied and developmental research within R&D activity seems to be the most common. This approach defines the rules of expressing outlays made for research and development activity in financial accounting (Rokita, 2014, pp. 202-203). Table 3 shows the basic characteristics of R&D work which impact the expression of costs connected to them from the perspective of accounting law.

*Table 3: A comparison between research work and development work (developed by the author on the basis of: Carlsson-Wall, Kraus, 2015, p. 185)*

Factors	Characteristics of research work	Characteristics of development work
Character of the idea, concept	experimental, theoretical, early, easily altered	aimed at practical uses, more difficult to change
Result	new knowledge, discovery of something new	new or significantly improved product or technology
Time horizon	far into the future, aiming at future product generations	shorter time horizon and completion time
Future economic benefits	effects are difficult to predict	greater probability of prediction

According to the Frascati Manual R&D activity can, potentially, be carried out in connection to any kind of business although with varying probability. At the same time the manual clearly warns that data concerning R&D activity published in compliance with national and international standards as well as with the recommendations of financial accounting may differ from data relating to R&D activity prepared in accordance with the recommendations presented in the manual itself. Some costs of R&D activity may be classified in the balance sheets of companies as capitalized and others, in turn, may be expressed as costs in the statement of

revenues and expenses (Podręcznik Frascati, 2015, p. 232). In business practice this causes a need to identify incurred expenditures according to different rules for financial accounting purposes, tax purposes and statistical research. Differences in methodological practices and in the utilization of definitions and recommendations are seen as the main reason limiting the comparability of R&D data from different countries.

### **3. DIFFERENT APPROACHES OF RECOGNIZING COSTS OF RESEARCH AND DEVELOPMENT WORK IN THE SYSTEM OF FINANCIAL ACCOUNTING**

The accounting expression of the process of innovation falls into the area of costs incurred for research and development activity. These costs are assessed and recorded with the real problem appearing at the moment of expressing these outlays in financial reports. Every entity which performs these types of tasks must disclose expenditures made in accordance with the formal requirements of existing accounting law. In the world of business accounting is commonly acknowledged as the language of business. Financial accounting (also called transactional accounting) provides information mainly to external users but is used also to prepare internal reports. Financial reporting can be divided into ownership accounting emitting financial reports and tax financing providing information to tax departments. In order to preserve reliability and credibility of financial accounting is subject to legal regulations which vary in different countries. For many years accounting has been impacted by the processes of harmonization, standardization and convergence on the international arena. International Standards of Financial Reporting play an important role in developing a uniform global system of financial reporting. Areas in which there are significant differences in accounting regulations include expression of expenditures for research and development work in financial reporting. Lack of a uniformed approach to R&D cost in accounting laws of various countries makes it difficult to prepare and compare financial statements. Costs of research and development work can be presented in financial reports in several ways (Krasodomska, Jonas, 2012, pp. 699-700, Gong, Wang, 2016, pg. 51; Giedroyć, 2018, pg. 158):

1. relating of all expenditures for research work and development work to the financial result in the period in which those costs have been accrued in accordance to the assumption that the entity is not able to prove the existence of the element of intangible assets which will generate probable future economic benefits,
2. postponing (suspending for a time) of all costs for research and development work until the moment when it can be assessed with certainty whether they will result in economic benefits in the future. In this case the entity can identify the element of intangible assets and then, through amortization, successively apply the value of that element to the financial result or write off all of the accrued costs from the financial result if the entity decides that they will not generate economic benefits in the future,
3. capitalize some of the costs of research and development – especially the cost of development work since the effects of this work, if they fulfill predetermined conditions, are more predictable.

“Intangible assets are increasingly seen as critical drivers for knowledge creation, innovation and consequently, economic growth entities” (Kramer, Marinelli, Iammarino, Diez, 2011, p. 447). These assets can be define as all non-material factor that contribute to the performance of firm in the production of goods or that are expected to generate future economic benefits to the entities. R & D is possibly the most important element of a company's organizational capital for innovations. The choice of a particular solution depends on legal regulations in force within this area as well as the freedom to choose left to the enterprise. Table 4 shows various accounting approaches of selected countries to research and development work costs.

*Table 4: International differences in accounting treatment of R&D expenditures (author's analysis based on: Krasodomska, Jonas, 2012, pp. 699-700; Gong, Wang, 2016, p. 51)*

Classifications	Research costs	Development costs
Mandatory expensing	Germany, Austria, Switzerland, UK, Austria, Poland, USA, IFRS	Germany, Australia, Austria, USA
Optional capitalization if certain conditions are met	Finland, France, Netherlands, Norway, Sweden	Finland, France, Netherlands, Norway, Sweden, UK, Poland
Mandatory capitalization if certain conditions are met	Australia	Australia, IFRS

Gong, Wang (2016, p. 50) point out that accounting for R & D activities has been a controversial topic for decades. In its essence research and development activity is typified by high level of uncertainty when it comes to providing benefits, meaning completion with commercial success, hence the first solution is based on relating the costs of all expenditures on R&D in the period in which they were made. All costs associated with research and development are presented in the income statement for the period. For this reasons countries such Germany, Austria, USA treat R & D expenditure as expenses regardless of the potential value of R & D activities. American companies listed on the stock market which use solutions dictated from the US GAAP (and which do not allow the capitalization of the costs of R&D work, with a few exceptions connected with software creation) disclose lower value of immaterial assets and profitability in comparison to those reporting according to IAS/IFRS. This approach also does not motivate to invest in research and development (Grabiński, Grabińska, 2018, p. 44). Incorrect presenting of the costs of this activity in financial reporting is seen as a flaw of this approach. This especially applies to enterprises incurring high expenditures on this type of activity which, according to this solution, decrease the entire financial result of the entity and, at the same time, within its assets an element of pro-innovative character is not expressed. For this reason there is a rise in the importance of descriptive supplementary information included in explanatory notes of financial statements or reports complementing those statements (such as Board Comments) which present the realization of a business model oriented at innovative activity. According to FASB rules, many reasons can explain the decision form immediate expensing of R & D costs. These reasons are related to uncertainty of future benefits, inability to measure future benefits, lack of casual relationship between costs and benefits, and lack of usefulness to investors. Most internally generated intangible investments are to be expensed when incurred (Zéghal, Maaloul, 2011, p. 264). The conservatism principle is the convention in accounting that when a degree of subjective interpretation is required, financial statement should consistently reflect the less optimistic case. Other solutions involve optional capitalization or mandatory capitalization after the fulfillment of certain conditions. The use of capitalization is supported by the fact that the information user receives data about the strategic element of assets which is connected with future long-term economic benefits. At the same time such principles as accrual basis, matching and caution are observed. If there is reasonable likelihood, that the company will derive future benefits from the costs of research and development, they can be capitalized and presented in the balance sheet as intangible assets. Countries such: France, Finland, Norway and Sweden allow companies to capitalize both R & D costs when certain condition are met. Next method implies a different approach to the cost of research and development. Under IAS 38 a company is required to classify research and development expenditure into research phase costs and development phase cost. The cost of research is expressed directly in the costs at the moment of its incurrence and presented in the statement of profit or loss. However, if there is a reasonable chance to generate future commercial returns, development costs have to be capitalized and carried on the balance sheet as intangible assets to be amortized over time.

The development costs must be capitalized provided such costs comply with certain conditions. According to IASB rules, if the company cannot distinguish the research phase from the development phase, the expenditure is treated as if it only were incurred in the research phase. Consequently, financial statement according to IFRS should be able to give much more information about R & D costs than other financial statement (Mindermann, Brösel, 2009, p. 12).

#### **4. RESEARCH AND DEVELOPMENT COSTS IN THE POLISH ACCOUNTING ACT AND IAS 38**

The regulations of balance sheet law determine the scope of information concerning ongoing research and development activities as well as where they must be presented. The Polish Accounting Act regulates the problem of expressing expenditures for research and development work in a relatively narrow range. According to accounting law only the element of the cost for completed development work is a specific item of intangible and legal assets. These costs are elements of intangible assets created by the economic entity through its own effort after the fulfillment of specified conditions. The problem is that the Polish Accounting Act does not precisely designate the concept or the scope of development work nor does it define the notion of research, its scope or type and the character of expenditures incurred. In economic practice, therefore, there appear problems in appropriate allocation of these costs to the correct phase of work especially since these activities are highly correlated. A broader solution is proposed in the International Accounting Standard 38 Intangible Assets (IAS 38) where research and development work has been defined. It should be mentioned that as a result of the harmonization process of accounting public entities which prepare consolidated financial reports are obligated to prepare them in accordance to IAS/IFRS. All other entities, on the other hand, may voluntarily use IAS/IFRS in regard to issues not regulated by the Polish Accounting Act (Ustawa z 19 września o rachunkowości, art. 10, par. 3). Table 5 presents a comparison of the scope of regulations of the Polish Accounting Act and IAS 38 in regard to the costs of research and development work. The currently utilized recording systems regulated by the Polish balance sheet law or by the guidelines of the international standard mainly aim at the fulfillment of reporting needs. Research work is unequivocally identified with the conceptual phase, the search for solutions initiated with the intent to gain and adapt new scientific or technological knowledge. The main aim of development work is such utilization of the results of research work in business activity which will ensure future economic benefits.

#### **5. CONSLUSION**

In summary, from the perspective of balance sheet law the initiation of the innovation process requires that the enterprise separate research work from development work. The classification of conducted work as well as the assessment of their results becomes a key issue. As can be seen the costs of research work influence the financial result of a period in which they were incurred. From the accounting point of view it is possible to activate only the costs of development work after specified conditions have been met. In practice, pursuant to the regulations of the Polish Accounting Act and IAS 38, many entities discern only the aspect of product and technological innovation of production.

*Table following on the next page*

*Table 5: Research and development work according to national and international accounting regulations (developed by the author on the basis of: Dyhdalewicz, 2017, p. 99; Ustawa z 29 września o rachunkowości; Międzynarodowy Standard Rachunkowości 38 Aktywa niematerialne, 2016, pp. 1369-1370)*

<b>Specification</b>	<b>Polish Accounting Act</b>	<b>IAS 38 Intangible assets</b>
<b>Elements of the innovation process: classification, definition</b>		
Research work	No definition, scope or indication how to express research work in the books or the financial report. In case of any doubts Art. 10 par. 3 of the act recommends using the IFRS/IAS.	Definition: Research work is the innovative, planned search for solutions initiated with the aim of gaining and adapting new scientific or technological knowledge. Examples of activities realized as part of research work. Expenditures for research must be expressed as costs at the moment of their incurrence.
Development work	No definition. List the conditions for recognition of costs for completed development work – incurred by the entity for its own use before initiating production or implementation of technology – as an element of assets classified as intangible or legal.	Definition: Development work is the practical implementation of scientific discoveries or achievements of other knowledge for planning or design of the production of new or significantly improved materials, equipment, products, technological processes, systems or services which occurs before the initiation of mass production or implementation. Examples of activities realized as part of development work.
<b>Disclosure in financial reports</b>		
Costs of research work	Influence the financial results of the period in which they were incurred – disclosed as costs at the moment of being incurred.	Influence the financial results of the period in which they were incurred – disclosed as costs at the moment of being incurred.
Development work	<ol style="list-style-type: none"> <li>1. Costs of in-progress, uncompleted development work are disclosed as long or short-term deferred accruals of costs and are disclosed in the balance sheet under fixed assets or under current assets.</li> <li>2. If it has been completed successfully the costs of development work are disclosed under fixed assets as an element of intangible and legal assets.</li> <li>3. The costs of development work are disclosed as costs of a given reporting period in the income statement if they do not qualify as costs of completed development work – result in failure.</li> </ol>	<ol style="list-style-type: none"> <li>1. The separation of research work and development work is not possible – all outlays should be treated as incurred during the research work stage and disclosed as costs within the reporting period during which they were incurred.</li> <li>2. The separation of research work and development work is possible - activation of development work costs after meeting the criteria resulting from conceptual assumptions and the specific criteria for recognizing a given resource as an intangible asset.</li> <li>3. Activation of expenditures for development work under intangible assets regardless of their state of completion, also during realization.</li> </ol>
Intended use of development work	For the needs of the entity itself.	Both for the needs of the entity itself as well as for sale.

From the perspective of accounting R&D activity is limited to the expression of expenditures made for research work and development work encompassing the development of new (or significantly improved) products or technologies. Definitions contained within the IAS 38 are mainly applicable to production companies. This kind of activity is more difficult to identify in, for example, service or sales companies. In these types of businesses it could lead to a lack of presentation of data relating to R&D activity in their annual reports.

Addressing of the issue of R&D activity in accounting seems to be justified for at least two reasons. First of all, economic entities devote significant outlays for research and development while the identification and presentation of these costs is still unresolved. The second reason involves the necessity of introducing changes in the Polish Accounting Act in regard to research and development work especially since small and medium enterprises do not apply within this area the solutions provided by IAS 38 and subsequent amendments of accounting law have not regulated this issue to a sufficient degree. It should be mentioned that as a result of the harmonization process of accounting public entities which prepare consolidated financial reports are obligated to prepare them in accordance to IAS/IFRS. All other entities, on the other hand, may voluntarily use IAS/IFRS in regard to issues not regulated by the Polish Accounting Act (AA, Art. 10 par. 3). From the perspective of accounting the costs of research work should be separated from those of development work. Both the IFRS as well as the Polish Accounting Act do not allow the qualification of costs of research work as an element of intangible assets. The Polish Accounting Act as well as the International Accounting Standard 38 allow the expression of expenditures incurred for development work as intangible assets. Both accounting systems, however, do not regard research work as an element of intangible assets. In Polish accounting law there is no definition of research work and development work. Since in practice there are a number of problems connected with distinguishing them from one another, as well as qualifying them, terminology should be supplemented by the explanation of these two terms.

#### LITERATURE:

1. Carlsson-Wall, M., Kraus, K., 2015, Opening the black box of the role of accounting practices in the fuzzy front-end of product innovation, *Industrial Marketing Management* 45, 184-194.
2. Dyhdalewicz, A. (2017). *Costs of research and development in Polish accounting law*. Private College of Economic Studies Znojmo: Proceedings of the 12th Annual International Scientific Conference: New Trends 2017: New Trends in Economics, Management, Marketing and Public Administration, 96-105.
3. Gabrusewicz, W. (2017), *Koszty prac rozwojowych w dokonaniach przedsiębiorstw*, In: A. Kamela-Sowińska (red.), *Finansyzacja i jej wpływ na globalny rozwój sprawozdawczości finansowej. Wybrane prace z dorobku naukowego Katedry Rachunkowości Uniwersytetu Ekonomicznego w Poznaniu w latach 2007-2017*, 435-445. Poznań: Uniwersytet Ekonomiczny w Poznaniu.
4. Giedroyc, M. (2018). Uznawanie kosztów badań i rozwoju w rachunkowości, *Prace Naukowe Uniwersytetu Ekonomicznego we Wrocławiu, nr 503 Współczesne problemy w nauce, dydaktyce i praktyce rachunkowości*, Wydawnictwo Uniwersytetu Ekonomicznego we Wrocławiu, 156-169.
5. Gong, J. J., Wang, S. I-L. (2016). Changes in the value relevance of research and development expenses after IFRS adoption, *Advances in Accounting, Incorporating, Advances in International Accounting*, 35, 49-61.
6. Grabińska, B, Grabiński, K. (2018). Wpływ nakładów na badania i rozwój na rentowność przedsiębiorstw. „*Zeszyty Teoretyczne Rachunkowości*”, tom 96(152), 43-62.
7. Knosla, R., Boratyńska-Sala, A., Jurczyk-Bunkowska, M., Moczala, A. (2014). *Zarządzanie innowacjami*. Warszawa: PWE.
8. Kramer, J-Ph., Marinelli, E., Iammarino, S., Diez, J. R. (2011). Intangible assets as drivers of innovation: Empirical evidence on multinational enterprises in German and UK regional system of innovation. *Technovation*, 31, 476-458.
9. Krasodomska, J., Jonas, K. (2012). Research and development costs in international accounting and Polish accounting and tax law. *Zeszyty Naukowe Uniwersytetu Szczecińskiego nr 690, Finanse, Rynki Finansowe, Ubezpieczenia nr 51*, 695-704.

10. Mindermann, T., Brösel, G. (2009). Does the capitalization of internally generated intangible assets according to IAS 38 really provide useful information. *Ekonomia Menedżerska*, nr 6, 7-16.
11. Piersiala, L. (2014). Rozwój przedsiębiorczości kreowanej przez działalność badawczą i prace rozwojowe. *Economics and Management*, 6(3), 302-314.
12. *Podręcznik Frascati 2015. Zalecenia dotyczące pozyskiwania i prezentowania danych z zakresu działalności badawczej i rozwojowej* (2018). OECD. Główny Urząd Statystyczny.
13. Rokita, S. (2014). Możliwości wykorzystania klasyfikacji działalności badawczo-rozwojowej w zarządzaniu przedsiębiorstwem, *Modern Management Review*, vol. XIX, 21(4), 252-212.
14. Stanisławski, R., Szymański, G., Trębska, J. (2018). *Open innovations w MSP i podmiotach ich otoczenia w kontekście rozwoju innowacyjnego*. Warszawa: PLACET.
15. Szczepaniak, P. (2016). Procesy zarządzania wiedzą w projektach badawczo-rozwojowych. *Studia Ekonomiczne. Zeszyty Naukowe Uniwersytetu Ekonomicznego w Katowicach*, Nr 278, 30-41.
16. Świadek, A. (2017). *Krajowy system innowacji w Polsce*. Warszawa: CeDeWu.
17. Ustawa z 29 września 1994 o rachunkowości, Dz.U. z 2018 r. poz. 395.
18. Wsparcie działalności B+R i nowych inwestycji, 2018, *Rzeczpospolita Poradnik Prenumeratora nr 10*.
19. Zéghal, D., Maaloul A. (2011). The accounting treatment of intangibles – A critical review of the literature: *Accounting Forum* 35, 262–274.



## AN ANALYSIS OF THE LEVEL OF INTERNET-BASED INFORMATION PROCESSING IN THE USA AGAINST A BACKGROUND OF GLOBALIZATION

**Anna Janiga-Cmiel**

*Ph.D., University of Economics in Katowice, Faculty of Management,  
Department of Statistics, Econometrics and Mathematics,  
1 Maja 50, 40-287 Katowice, Poland,  
anna.janiga-cmiel@ue.katowice.pl*

### **ABSTRACT**

*Globalization is one of the drivers behind scientific and technological advances, including the development of information technologies. It impacts on a great number of economic and social spheres of human activity. The paper presents an analysis of a particular set of diagnostic features. The variables, whose relevance and statistical accuracy were first verified, formed a basis for the classification of the the US states in terms of the computer and Internet use by physical persons aged 16-74. The data comes from the statistical yearbooks published by the Central Statistical Office and from the Eurostat websites; it covers the years 2016, 2010 and 2005. The aim of the analysis is to apply a selected taxonomic method – the Wrocław method for the analysis of the US states in terms of the computer and Internet use – to identify groups of the US states with a similar level of Internet usage.*

**Keywords:** *Econometric Methods, Globalisation, Information Society, Taxonomic analysis*

### **1. INTRODUCTION**

The continuous rapid development of the information technologies, taking place against a background of globalization, significantly contributes to the creation of an increasingly developed information society. Globalization offers us an opportunity to: "understand the process of entering the new millennium by the human society collective as a multidirectional process, where the geographical constraints which have so far determined the forms of the socio-cultural organization are weakening and the awareness of the erosion of these constraints is growing" (Kempty, 1998, pp. 241). Globalization has a considerable impact on the stages of development and the construction of the information society. The information society is "a social system, developed as a result of the modernization processes, in which information systems and information resources determine the employment structure and an increase in social wealth (national income), and provide a basis for the civilization's orientation". (Bliźniuk, Nowak, 2005, pp. 15-40) We live in the times when information and information processing are becoming an essential factor in our functioning, and information transmission is getting increasingly faster and easier, provided you live in a country where new information technologies are commonly accessible (Globan-Klas, Sienkiewicz, 1999, pp. 40-117). The development of these technologies is also indispensable for the economic development of countries. The Internet and information technologies are an integral part of our daily life and work. It is observed that the informatization level of a country is closely related to its development. Obviously, we must not forget that the information society and globalization exert adverse effect on our life as well. Cyberterrorism, cyberviolence, hacker attacks, the disappearance of national identities, the erosion of mother tongues, digital exclusion are just a few examples of the challenges we are facing (Globan-Klas, Sienkiewicz, 1999, pp. 40-117), (www1). The aim of the analysis is to apply a selected taxonomic method – the Wrocław method for the analysis of the US states in terms of the computer and Internet use in the years 2005, 2010, 2016 – to identify groups of the US states with a similar level of Internet usage.

## 2. TAXONOMIC METHODS

The statistical methods of multidimensional comparative analysis, and the taxonomic and factor methods in particular, prove useful in research involving a multitude of objects described by numerous variables and studied in various periods of time. The selection of the most suitable methods of multidimensional comparative analysis is determined by the aim and the scope of a study. Taxonomy is a science of classification principles, and the classification methods are employed in various scientific disciplines. The first classification algorithms were developed in the 1950s and 1960s, but were improved over time so that they could serve a variety of purposes they were applied for. J. Czekanowski, a Polish anthropologist, introduced quantitative methods into taxonomy, while J. Fierich was the first scientist to employ the taxonomic methods for research in economics. Taxonomy and its applications were undergoing continuous development and modifications, adapting to research in the socio-economic fields as well. The fundamental aim of object clustering is to identify groups of homogeneous objects, similar to one another in terms of the internal structure of the variables that describe them. Thus, clustering has to fulfil two criteria, i.e. homogeneity and heterogeneity. In the case of homogeneity, we look at the objects that belong to the same group and, in addition, at those that bear close similarity. As far as heterogeneity is concerned, we deal with the objects which belong to various groups and which are the least similar to one another (Grabiński and others, 1980, pp.70-80), (Pociecha and others, 1988).

### 2.1. Wrocław Method

The Wrocław method is one of the area delimitation methods, where a multidimensional space, comprising points that represent objects, is divided into disjoint subareas: disjoint hyperspheres or hypercubes (Panek, 2009, pp. 148-153). The groups are made of objects located in subareas. The hypersphere radius as well as the number of hypercubes are usually determined arbitrarily. The Wrocław method, also known as the hypersphere taxonomy, was developed by researchers from Wrocław, working under the supervision of Z. Hellwig. It uses the elements of a matrix showing distances between the objects under study (matrix of Euclidean distances) (Grabiński and others, 1989, pp.70-80), (Panek, 2009, pp.148-150). The calculated elements of the matrix form a basis for the successive operations:

1. We determine the radius of the hyperspheres  $d_0$  using one of the following relations:

$$d_0 = a \cdot S(d) + \bar{d}, \quad (1)$$

Where 
$$\bar{d} = \frac{1}{k} \sum d_i, \quad S(d) = \sqrt{\frac{1}{k} \sum (d_i - \bar{d})^2} \quad \text{and} \quad d_i = \min_{i'} \{d_{ij'}\}, \quad (2)$$

$a$ - the value of the set parameter .

2. We create hyperspheres of a certain radius centered at the objects which are being grouped.
3. We calculate the number of objects belonging to each hypersphere.
4. The objects belonging to the most populated hypersphere form groups and are excluded from the subsequent partitioning.
5. If a few hyperspheres with a maximum number of objects are identified, we should group the objects belonging to the hypersphere whose center is closest to the coordinate system origin.

In order to establish other groups, we repeat the whole process, following the procedure presented above (Panek, 2009, pp. 58-114).

This time, however, we do not take into consideration the objects that are part of the already separated groups. The process finishes when we obtain disjoint and exhaustive groups of objects. A great disadvantage of the Wrocław method is that it leads to the creation of a large number of groups composed of a small number of elements (Pociecha and others, 1988).

### **3. THE APPLICATION OF THE WROCLAW METHOD FOR THE ANALYSIS OF THE US STATES IN TERMS OF THE COMPUTER AND INTERNET USE IN THE YEARS**

The first stage of the study focused on the United States in the year 2005, and next in the years 2010, 2016. The set of the diagnostic variables, which was established based on the descriptive and formal analysis of these variables, included (Janiga-Ćmiel, 2016), (Janiga-Ćmiel, 2017A), (Janiga-Ćmiel, 2017B), (Janiga-Ćmiel, 2013):

- X<sub>1</sub>-Internet use by individuals,
- X<sub>2</sub>-Households with broadband access,
- X<sub>3</sub>-Individuals using the internet by place of use,
- X<sub>4</sub>-Reasons for not having internet access at home,
- X<sub>5</sub>-Individuals using mobile devices to access the internet on the move,
- X<sub>6</sub>-Households without access to a computer.

The data comes from the statistical yearbooks published by the Central Statistical Office and from the Eurostat websites; it covers the years 2016, 2010 and 2005. Based on the standardized values of the diagnostic variables for the year 2016 (Panek 2009, pp. 60), a matrix of Euclidean distances  $D$  between the US states was calculated. The value of the hypersphere radius, calculated according to formula (1), stood at  $d_0=3,32$ . Next, hyperspheres of the calculated radius, centered at the investigated states, were constructed. The analysis of the results showed that state Maryland is the center of the most populated hypersphere, which comprises:  $G_1=\{\text{Maryland, Alaska, New York, Mississippi, Hawaii, Massachusetts, Washington, Tennessee, Florida, Utah, Wisconsin, North Carolina, Maine, Minnesota, Connecticut, New Jersey, Nevada, Louisiana, New Hampshire, Pennsylvania, Idaho, Georgia, Vermont, Illinois, Missouri, Indiana, Texas, Iowa, North Dakota, Oklahoma, Ohio, Montana, Michigan, Virginia, Wyoming, Indiana, Rhode Island, California}\}$ . These states form the first group of states with a similar level of the computer and Internet use in the year 2005. The next stage of the study involved analysing the states that made up the other hyperspheres. As a result, we obtained hyperspheres comprising the greatest number of states, whose centers were states Kentucky, Nevada respectively. Finally, taking into consideration the distances of the respective centers and the coordinate system, we identified the following groups:

$G_2=\{\text{Kentucky, Oregon, West Virginia, South Carolina, Kansas, District of Columbia, Delaware, South Dakota}\}$ ,  $G_3=\{\text{Nevada, Colorado}\}$ .

The one-element groups of states include:

$G_4=\{\text{Nebraska}\}$ ,  $G_5=\{\text{Alabama}\}$ ,  $G_6=\{\text{Arkansas}\}$ ,  $G_7=\{\text{New Mexico}\}$ ,  $G_8=\{\text{Arizona}\}$ .

The same analysis was conducted for another year under study, i.e. 2010.

This time, the following groups were formed:

$G_1=\{\text{Connecticut, New York, Colorado, Virginia, Hawaii, New Jersey, Maryland, Alaska, Massachusetts, Washington, Minnesota, California, New Hampshire, Nevada, Utah, Alabama, Nebraska, North Carolina, Rhode Island, Delaware, Oregon, Ohio, Missouri, North Dakota, Wyoming, Maine, Texas, Arizona, Florida, West Virginia, Vermont, Tennessee, Georgia, Oklahoma, Louisiana}\}$ ,  $G_2=\{\text{Michigan, Pennsylvania, Wisconsin, Idaho, District of}$

Columbia}, G<sub>3</sub>={Mississippi}, G<sub>4</sub>={Illinois}, G<sub>5</sub>={Indiana}, G<sub>6</sub>={South Carolina}, G<sub>7</sub>={South Dakota}, G<sub>8</sub>={Kansas}, G<sub>9</sub>={Iowa}, G<sub>10</sub>={New Mexico}, G<sub>11</sub>={Arkansas}, G<sub>12</sub>={Kentucky}, G<sub>13</sub>={Montana}.

The analysis for the year 2016 led to the identification of the following groups:

G<sub>1</sub>={New York, New Jersey, Hawaii, California, Alaska, Washington, District of Columbia, Connecticut, Minnesota, New Hampshire, Utah, Maryland, Massachusetts, Rhode Island, Oregon, Tennessee, Florida, Pennsylvania, Delaware, Arkansas, Maine, Colorado South Dakota, Idaho, West Virginia, Alabama, Oklahoma, Illinois, Iowa, Vermont, Nebraska, North Carolina, Texas, Montana, Ohio}, G<sub>2</sub>={Mississippi, New Mexico, Louisiana, Missouri, Wisconsin, North Dakota}, G<sub>3</sub>={South Carolina}, G<sub>4</sub>={Arizona}, G<sub>5</sub>={Indiana}, G<sub>6</sub>={Georgia}, G<sub>7</sub>={Kansas}, G<sub>8</sub>={Michigan}, G<sub>9</sub>={Wyoming}, G<sub>10</sub>={Virginia}, G<sub>11</sub>={Kentucky}, G<sub>12</sub>={Nevada}.

#### 4. CONCLUSION

The analysis of the level of the Internet and computer usage was performed by means of the taxonomic grouping method with the aim of identifying groups of the US states that are homogeneous in this respect. The variables which were selected for the purpose of the study exert significant influence on the investigated phenomenon. The analysis carried out for the year 2005 resulted in the identification of two most populated groups, which comprise the following states: G<sub>1</sub>={Maryland, Alaska, New York, Mississippi, Hawaii, Massachusetts, Washington, Tennessee, Florida, Utah, Wisconsin, North Carolina, Maine, Minnesota, Connecticut, New Jersey, Nevada, Louisiana, New Hampshire, Pennsylvania, Idaho, Georgia, Vermont, Illinois, Missouri, Indiana, Texas, Iowa, North Dakota, Oklahoma, Ohio, Montana, Michigan, Virginia, Wyoming, Indiana, Rhode Island, California} and G<sub>2</sub>={Kentucky, Oregon, West Virginia, South Carolina, Kansas, District of Columbia, Delaware, South Dakota}. The make-up of the groups is different from the composition of the groups formed in the years 2010 and 2016. We can observe, however, that in each period under study the first group encompassed: Alaska, New York, Mississippi, Hawaii, Massachusetts, Washington, Tennessee, Florida, Utah, Wisconsin et cetera. In the USA these states are recognized as the wealthiest, and, what is more, in comparison with other states, they enjoy a higher level of economic development. Thus, we can conclude that despite the passage of time, these states offered the greatest opportunities for the development of the Internet and computer usage in the years under study. Taking into consideration such indicators as the unemployment rate, education level and median family income, Alaska, Maryland and New Jersey were classified in recent years as belonging to the wealthiest US states. Washington, for example, is the seat of big and successful companies, such as Microsoft, Starbucks and Amazon. North Dakota, where shale gas and oil are extracted, is becoming a state with the lowest unemployment rate. In the grouping procedure, the poorest states were assigned to the group with the lowest level of Internet-based information processing - the one-element groups. The group comprises Mississippi, which has the highest unemployment rate and the lowest GDP per capita in the USA, New Mexico bordering Mexico, Arkansas, and Nevada (despite rich Las Vegas located in this state). Another state classified as a poor one is Alabama. Although it boasts a high rate of economic growth, resulting i.a. from the fact that three international auto companies, Honda, Hyundai and Mercedes-Benz, have located their factories there, Alabama still has a high unemployment rate. Rapid economic growth was also recorded in Colorado, famous for marijuana cultivation. Today's society is addicted to all kinds of technological solutions and its development depends mainly on the accessibility to the information technologies. A highly-developed and well-educated society processes information resources to a greater extent than a less-developed and worse-educated one.

People living in big affluent cities have better educational chances and plenty of opportunity for using various technologies in their personal lives and in the workplace compared to the inhabitants of small towns. Thus, the significant differences in the level of the IT technology use arise from the place of living. Summing up, we can say that the development of the information society is closely related to the economic development.

#### LITERATURE:

1. Bliźniuk, G., Nowak J.S. (2005), *Spoleczeństwo informacyjne 2005*, Katowice, PTI, ( pp. 15-40)
2. Goban-Klas, T., Sienkiewicz, P. (1999), *Spoleczeństwo informacyjne. Szanse, zagrożenia, wyzwania*. Kraków, Wydawnictwo Fundacji Postępu Telekomunikacji, (pp. 40-117).
3. Grabiński, T., Wydymus, A., and Zeliaś, A. (1989), *Metody taksonomii numerycznej w modelowaniu zjawisk społeczno-gospodarczych*. Warszawa, PWN, (pp.71-100).
4. Janiga-Ćmiel, A. (2016), *Analiza społeczeństwa informacyjnego wybranych krajów*, Studia Ekonomiczne, Zeszyty Naukowe nr 301, Katowice, Wydawnictwo UE w Katowicach, ( pp.94-103).
5. Janiga-Ćmiel A. (2017a), *A Comparative Analysis of the Information Society In Poland and Selected Countries*. Proceedings of 35<sup>th</sup> International Conference Mathematical Methods In Economics, Hradec Kralove, Czech Republic, (pp. 283-288).
6. Janiga-Ćmiel, A. (2017b), *Globalisation and the information society in Poland and selected countries*. Proceedings of 17<sup>th</sup> International Scientific Conference. Globalization and its socio-economic consequences, Zilina, Czech Republic, (pp. 787-795)
7. Janiga-Ćmiel, A. (2013). *Detecting Shocks in The Economic Development Dynamics of Selected Countries*. *Folia Oeconomica Stetinensia*, 13 (2), (pp. 120-133)
8. Kempty M. *Globalizacja*. Encyklopedia socjologii, Oficyna Naukowa, Warszawa 1998, (pp. 241)
9. Panek, T. (2009), *Statystyczne metody wielowymiarowej analizy porównawczej*. Warszawa: Szkoła Główna Handlowa w Warszawie – Oficyna Wydawnicza, (pp. 58-114)
10. Pocięcha, J., Podolec B., Sokołowski, A., and Zajac, K. (1988), *Metody taksonomiczne w badaniach społeczno-ekonomicznych*, Warszawa, PWN, (pp. 36-100)
11. (www1) *Spoleczeństwo informacyjne w Polsce. Wyniki badań statystycznych z lat 2013-2017*. (2007). Retrieved 20.06.2018 from <http://stat.gov.pl/obszary-tematyczne/nauka-i-technika-spolczenstwo-informacyjne/spoleczenstwo-informacyjne>

## THE POLITICAL AND ECONOMIC INTEGRATION OF LATIN AMERICA

**Mirosław Przygoda**

*University of Warsaw, Faculty of Management  
mirosławprzygoda@wp.pl*

### **ABSTRACT**

*It was in the early 19<sup>th</sup> century that the idea of uniting the entire continent of South America under the banner of a single great nation was first conceived. Several former Spanish Empire estates and provinces, having broken free from the reign of Spain, decided to unite as a single state organism. However, it was not until the second half of the 19<sup>th</sup> century that this idea of unity began to come to life. There were several favourable factors at play: the nation states, similar social structures, coinciding economic situations, a common history, a common Catholic creed, cultural relatedness and the weakening of the Kingdom of Spain. The rapid inflow of new ideas from Western Europe – new philosophy and ideals of the Enlightenment – also played a major role in the process. Unfortunately, it ended in failure almost as soon as it started. Even at the beginning of the second half the 19<sup>th</sup> century, new issues arose which managed to successfully shut down the ongoing efforts, primarily including the increasing sense of difference between the individual nations' ideals and beliefs, as well as a feeling of strong territorial independence of the local populations. These differences had the painful and bloody result of nearly a hundred years of conflict and strife across the entire continent. Another major effect was the formation of several independent, sovereign countries, whose borders have almost not changed since. Due to the success of the Cuban Revolution, the thought of a political and territorial unity of Latin America resurfaced in the 1950s. The ideals of socialism and communism are well received among the poorest classes, with all manner of leftist groups propagating, among others, the concept of creating a melting pot of the various nations in the region. On the other hand, far right and oftentimes authoritarian parties tended to seize power in the individual countries, frequently with external support. These parties were not always opposed to the idea of collaboration and integration with their neighbours, but would accept it merely in terms of economy. Nowadays, Latin America is internally torn by diametrically opposed political and ideological forces to a degree unlike any other continent. Which of these forces will prevail and complete the task of uniting the region has not yet been determined.*

**Keywords:** *Latin America, idea, integration, conflict, strife, united*

### **1. INTRODUCTION**

Latin America is the name for the vast territory on the South American continent itself along with adjacent islands. In the past, they were colonised and administrated by Spain, Portugal and France, and their populations still speak Romanic languages. Nowadays, the region consists of twenty sovereign nations as well as thirteen autonomous territories remaining dependent upon or associated with their parent European metropolises. By language, the Latin America is traditionally divided into the following:

- Hispanic America – the region where the official language is Spanish. It comprises Argentina, Bolivia, Chile, Colombia, Costa Rica, Cuba, the Dominican Republic, Ecuador, El Salvador, Guatemala, Honduras, Mexico, Nicaragua, Panama, Paraguay, Peru, Puerto Rico, Uruguay and Venezuela.
- Portuguese America (Luso-America) – the Portuguese-speaking region. In South America this includes only one country – Brazil.
- Creole America – i.e. the area where the official language is a heavily modified and simplified version of French (in fact a creole).

In the Middle and South Americas this includes Haiti and French Guyana, as well as two overseas French colonies: Martinique and Guadalupe.

- Ibero-America – i.e. the Portuguese- and Spanish-speaking region of Latin America, combining Hispanic America and Portuguese America into one.

By geography, Latin America as a whole can be divided into four distinct subregions. If defined as all of the Americas south of the United States, the basic geographical subregions are (Garcia M. A. 2011):

- North America – represented by Mexico, the only country there.
- Central America – this subregion includes Costa Rica, Guatemala, Honduras, Nicaragua, Panama, Salvador, as well as Belize – a former British colony (functioning under the name of British Honduras until 1981); in this area, Spanish is the common language.
- The Caribbean – this subregion includes the Dominican Republic, Haiti, Cuba, Guadalupe, Martinique, Puerto Rico, Saint Martin (only the northern part of the island is French-speaking), Saint Barthélemy, Saint Lucia and Dominica (in the last two, a French-based creole is used).
- South America – the largest of the subregions, which includes Argentina, Bolivia, Brasil, Chile, Colombia, Ecuador, French Guiana, Paraguay, Peru, Uruguay and Venezuela.

The area of Latin America is 19,197,000 km<sup>2</sup> and its population is over 656 million (Ludnosć Ameryki Południowej, 2018). Out of these, Spanish is the native language of around 436 million, Portuguese is the native language of 209 million and a little over 12 million speak either French or a related language. Nearly 80% are Catholic, amounting to about 525 million adherents. The average age in South America is 32.5, and professionally active people constitute about 64.4% of the population. In 2018, the unemployment rate in the region was estimated at 8.1% (International Labour Organisation, 2018). The total 2017 GDP (in current USD) of the continent was 5.955 trillion (World Bank, 2018). To the west, the continent borders the Pacific, while the eastern coast of Latin America along with the Caribbean open out to the Atlantic. The region occupies all climate zones: from the tropical rainforest climate near the equator, through tropical, subtropical and temperate zones, to the subpolar zone at the very southern end of South America.

## **2. THE IDEA OF INTEGRATION**

Shortly after Christopher Columbus discovered the New World in 1492, Spain began conquering the new lands across the Atlantic. Having laid claim to the islands of the Caribbean, it proceeded to annex the area of today's Mexico between 1518 and 1521. The seized territory was named New Spain. Between 1531 and 1533, the Spanish began conquering the South American continent itself, i.e. the territories of today's Colombia, Ecuador and Peru, stretching along the northern coast of the Pacific. Victorious, they continued further south. Chile fell prey to them next, and before the second half of the 19<sup>th</sup> century, they also managed to colonise the territories of today's Argentina, Paraguay and Uruguay. Through bloody clampdown, the Spanish seized control of the entire South America and most of Middle America – the exception being Brazil, which was granted to Portugal according to the 1494 Treaty of Tordesillas that divided the New World. The two main Spanish colonies, stretching along the coast of the Pacific, were named New Castile and New Toledo and later on the two were combined and renamed Peru. Administratively, New Spain and Peru were two separate Spanish overseas colonies, each governed by Spanish intendants in the rank of viceroys: the Viceroyalty of New Spain was established in 1527, and the Viceroyalty of Peru – in 1544 (Sapeta, 2016). The desire of the inhabitants of Spanish colonies to break free from under the Crown's authority

manifested in the form of military uprisings between 1810 and 1826. After a long series of defeats, fate eventually smiled upon the revolutionaries. Vast multitudes of people were led to victory and independence by Simón Bolívar, José de San Martín, Andrés de Santa Cruz and Antonio José de Sucre among others. Following his military success, José de San Martín declared the independence of Argentina on July 9<sup>th</sup>, 1816, while up north, Simón Bolívar freed Venezuela, Colombia and New Granada, thus achieving his dream of a united Latin America – but only partially. On his initiative, the Gran Colombia was born in 1819, uniting Venezuela, Colombia, Ecuador and Panama (Burek R., 2000); however, the state fell apart in the early 1830s due to a military coup followed by a failed assassination attempt on Bolívar himself. A similar fate befell another coalition of Latin American countries – the Federal Republic of Central America, comprising Guatemala, El Salvador, Honduras, Nicaragua and Costa Rica, as well as, from 1838 onwards, Los Altos. In this case, the reason of the dissolution was the 1838-1840 civil war instigated by the Roman Catholic Church and wealthy land owners. (Sapeta, 2016). It was during the period of the struggle for independence that the thought of unifying the entire Latin America as a single nation arose – more specifically, it was during the 1811-1812 Venezuelan civil war. The hero of the entire continent and advocate for a federation of all Hispanic American countries – Simón Bolívar – is widely considered to be the father of this idea. However, it was mostly abandoned in the 19<sup>th</sup> and 20<sup>th</sup> centuries as a result of numerous armed border conflicts in Latin America which instilled in the majority of citizens a strong sense of injustice at the hands of neighbouring nations and, as a result, nationalistic animosities between them. Currently, the idea of uniting the continent is especially prominent in proletarian and revolutionary circles, as well as radical leftist groups of all stripes. Conversely, it is strongly opposed by right-wing authorities, the Catholic Church, nationalistic political parties, large landowners, as well as local representatives of foreign companies and corporations.

### **3. ECONOMIC INTEGRATION**

Organisations promoting trade and economic intergration of Latin American countries date back to the early 1960s. On 18<sup>th</sup> February, 1960, during a meeting in Montevideo, the capital of Uruguay, the Treaty of Montevideo was signed, which brought about the establishment of Asociación Latinoamericana de Libre Comercio (ALALC) on 2<sup>nd</sup> June the following year, better known by its English name of the Latin American Free Trade Association (LAFTA) (Osmanczyk E., 1974). The membership originally consisted of seven Latin American countries: Argentina, Brazil, Chile, Mexico, Paraguay, Peru and Uruguay, later to be joined by Colombia, Venezuela, Ecuador and Bolivia. The stated goal of the organisation was to institute free trade within 12 years through gradual reduction of mutual customs and non-tariff barriers and also to help improve the region's competitiveness on the international market. The overall process of removing the major barriers was planned out for a 20-year period. In 1980, LAFTA transformed into LAIA (the Latin American Integration Association). Its main goal, apart from maintaining the already functioning free trade zone, was to create a common market. However, the plan did not include any specific schedule. Instead, everything was based simply on casual agreements between specific members. There was no plan for negotiations, either, nor was there any interest in coordinating member states' trade politics or amending laws concerning the exchange of services, all of which stood in the way of the organisation's goals. Still, despite large differences between the member countries and only a limited degree of their integration, LAFTA played a significant role in the economic history of South America (Bryk, 2018). In 1980, the organisation was transformed again into Asociación Latinoamericana de Integración – the Latin American Integration Association (ALADI). On 2<sup>nd</sup> January, 1999, the organization was joined by Cuba despite its seemingly incompatibly different political leaning and social system. This allowed the country ruled by the Castro brothers to mostly free itself from the trade and economic blockade imposed upon it by the USA. Nowadays, ALADI is still growing



and constantly endeavouring to fulfill its goals and tighten the cooperation between its twelve current members. Apart from ALADI, there are several more economic integration organisations operating in Latin America. Their stated goals mostly revolve around the ideas of economic cooperation and dissolution of customs barriers and other limitations. Out of these groups, Mercosur (derived from Spanish Mercado Común del Sur, i.e. the Southern Common Market) is considered the most influential, maintaining the most stable free trade zone in South America (Long N.V., 2014) and ensuring a free flow of workforce and material goods. Mercosur is a South American trade bloc established by the Treaty of Asunción (1991) and Protocol of Ouro Preto (1994). Its full members are Argentina, Brazil, Paraguay and Uruguay. Venezuela is a full member but has been suspended since December 1<sup>st</sup>, 2016. Its associate countries are Bolivia, Chile, Colombia, Ecuador, Guyana, Peru, and Suriname, and its observer countries are New Zealand and Mexico (De West, 2015). The bloc comprises a population of more than 270 million people, and the combined GDP (PPP) of the full member nations is in excess of 3 trillion USD a year according to the International Monetary Fund's numbers, making Mercosur the 5<sup>th</sup> largest economy in the world. It is the fourth largest trading bloc after the European Union (Klonsky J., Hanson S., 2019). The combined territory of Mercosur's full member states is a continuous and uniform expanse of land stretching from the coast of the Caribbean Sea to the subpolar Patagonia reaching out south in the direction of Antarctica. With the exception of the coastless Paraguay, they are located on the east, towards the Atlantic. In terms of economy, the most important information about the members of Mercosur is presented in Table 1.

*Table 1: Economic data about the countries of the Mercosur (2018)*  
 (from: *World Economic Outlook Database, International Monetary Fund 2018*)

<b>Country</b>	<b>GDP (nominal) in USD millions</b>	<b>GDP (PPP) in USD millions</b>	<b>Merchandise exports in USD billions*</b>	<b>Merchandise imports in USD billions*</b>	<b>Exports to Mercosur (% of each)**</b>	<b>Imports from Mercosur (% of each)**</b>
Argentina	475,429	918,572	84.3	73.9	25.2	33.6
Brazil	1,909,386	3,370,620	250.8	219.6	11.1	8.9
Paraguay	41,851	95,011	9.8	12.1	29.0	42.0
Uruguay	60,933	81,573	8.0	10.7	33.8	48.8
<b>Total</b>	<b>2,487,599</b>	<b>4,465,776</b>	<b>445.5</b>	<b>362.7</b>	<b>13.2</b>	<b>16.8</b>

\* data for 2011 from *Country Comparison: Exports & Imports. The World Factbook. Central Intelligence Agency (CIA), 2011.*

\*\*data for 2010 from *Mercosur–EU Bilateral Trade and Trade with the World. DG Trade. March 2012, p. 6.*

The vast differences of both values of GDP and in the trade data for the full member countries of Mercosur in Table 1 are mostly due to the large discrepancies in their areas, populations and economic development, as shown in Table 2.

*Table 2: Information and statistical data about the countries of the Mercosur (2017)  
 (from: The World Factbook. Langley, Virginia, CIA, retrieved 1<sup>st</sup> September 2018)*

<b>Country</b>	<b>Government (political system)</b>	<b>Total area (in km<sup>2</sup>)</b>	<b>Population (in millions)</b>	<b>Density</b>	<b>Language</b>	<b>Capital (population)</b>
<b>Argentina</b>	Federal presidential constitutiona l republic	2,780,400	43.8	14.9/km <sup>2</sup>	Spanish	<b>Buenos Aires</b> (2.89 million)
<b>Brazil</b>	Federal presidential constitutiona l republic	8,515,767	207.7	23.1/km <sup>2</sup>	Portuguese	<b>Brazilia</b> (3.04 million)
<b>Paraguay</b>	Unitary Dominant- -party presidential republic	406,752	6.7	16.4/km <sup>2</sup>	Spanish and Guarani	<b>Asuncion</b> (0.52 million)
<b>Uruguay</b>	Unitary presidential constitutiona l republic	176,215	3.4	24.0/km <sup>2</sup>	Spanish	<b>Montevideo</b> (1.31 million)

Another organisation, the Andean Community (Spanish Comunidad Andina, CAN), has ambitions to be a counterweight of sorts to Mercosur. This trade bloc came into life in 1969 but was called the Andean Pact until 1996. This organisation is a customs union comprising four full member countries: Bolivia, Colombia, Ecuador and Peru. Its associate members are Argentina, Brazil, Paraguay, Uruguay and Chile, while the only observer country is Spain; from 1973 to 2006, Venezuela was also a member of the alliance. Along with Chile, the combined territories of the four founding countries stretch from the Caribbean Sea to Cape Horn in Tierra del Fuego, covering the entire western, Pacific-bordering coast of South America. The Andean Community has more than 101 million inhabitants living over an area of 3.809.100 km<sup>2</sup>. Its GDP amounted to 745.3 billion USD in 2005 (this includes Venezuela, who was a member at the time), while its estimated GDP PPP for 2011 amounts to 902.86 billion USD (this time excluding Venezuela) (IMF, 2011). Overall, the Andean Community and Mercosur constitute the two main trading blocs of South America. In 1999, these organizations began negotiating a merger with a view of creating the South American Free Trade Area (SAFTA). Eventually, on 8<sup>th</sup> December, 2004, they signed a cooperation agreement and published a joint letter of intention for future negotiations towards integrating all of South America in the Union of South American Nations – USAN (Spanish UNASUR – Unión de Naciones Suramericanas, Portuguese UNASUL - União das Nações Sul-Americanas). Apart from Mercosur and the Andean Community, Latin America is home to several local intergration groups aiming to reduce or entirely abolish customs barriers and establish economic unions, including: the Latin American and the Caribbean Economic System, officially Sistema Económico Latinoamericano y del Caribe (SELA), the Rio Group (G-Rio), the Central American Integration System (Spanish SICA – Sistema de la Integración Centroamericana), the Dominican Republic-Central America Free Trade Agreement (CAFTA-DR), the Bolivarian

Alliance for the Peoples of Our America (ALBA or ALBA–TCP Spanish Alianza Bolivariana para los Pueblos de Nuestra América). CARICOM (The Caribbean Community and Common Market) is another fairly powerful organisation; established mainly by the English-speaking parts of the Caribbean, CARICOM has become multilingual in practice with the addition of Dutch-speaking Suriname on 4<sup>th</sup> July, 1995, and Haitian Kreyòl- and French-speaking Haiti on 2 July 2002. Furthermore, it was suggested that Spanish should also become a working language (Archived copy, 2011). Currently, CARICOM consists of 15 full members, 5 associate members and 8 observers. All of the associate members are British overseas territories. Should the Mercosur and the Andean Territory merge, it is reasonable to believe that CARICOM countries would also be interested in joining the newfound Union of South American Nations. This is because there is a definite trend among the South American and Caribbean countries for safeguarding themselves against the attempts by the USA to impose political and economic control over the region. USAN's inception would prove a viable alternative for all of them. The fact that there are two large independent and well integrated economic unions existing in South America is simultaneously a source of problems and a driving factor behind the dynamic process of consolidation of each of them. It is problematic in that any country which has not yet decided where to belong, or has changed its mind since, is faced with a difficult dilemma. The latter is exemplified by Venezuela, which was part of the Andean Community from 1973 to 2006 and a full member of Mercosur from 2012 to 2016. As for the increasingly dynamic integration, the processes involved often seem merely populist and PR-oriented. Examples include the removal of visa requirements and introducing a common passport (the Andean Passport) for the citizens of Bolivia, Colombia, Ecuador, Peru and Venezuela, as well as the introduction of unified model of licence plates (Mercosur common plates) by Mercosur in 2016, following the EU's example; this applied to vehicles in Argentina, Brazil, Paraguay, Uruguay and Venezuela. Broadening the economic integration of the Andean Community and Mercosur might create an impetus to truly unite the major South American countries in a single coherent economic bloc. However, even a successful economic integration will most likely not be followed by a political one. Language, cultural and developmental differences between individual countries, as well as their leaders' ambitions towards political independence, appear to be insurmountable obstacles in the way of such a goal. Another concern among the citizens and politicians of South America in the region is Brazil's potential domination – or even hegemony. After all, historically it has not hesitated to take advantage of its geographical size, large population and dynamic economy to further its influence on the international arena (Horbeek B., 2016). In its most recent constitution (1988) Brazil included a provision stating that uniting Latin America is very significant to its future political strategy – and these are no mere words, either, as evidenced, for example, by their level of engagement in the BRICS group, which is very open in its attempts to shift the world balance of power. South America's largest country – as well as the only Portuguese-speaking one – is, in many respects, well above its neighbours, making them feel uneasy about its potential domination and averse to the idea of their political dependency on it.

#### **4. POLITICAL INTEGRATION**

Admittedly, much has been done in Latin America, and especially in its South American region, towards economic integration and towards building a federation administratively resembling the European Union. However, while embracing the development of a closer, mutually beneficial economic cooperation, the governments of most countries are far from accepting one of the main ideas of Bolivarianism – the creation of a single independent nation spanning the entire continent. Such ideas are opposed by wealthy land owners, the conservative Catholic Church, representatives of great international enterprises, the military high commands and the leaders of ruling right-wing parties.

This categorically prevents any balance of political power, as well as any broader social reforms, such as universal health care, free academic education, governmental funding of social assistance institutions, women's equality, parcellation of land amongst the poorest citizens or taxing the wealthiest ones at a higher rate. Considering also the world of difference between the wages of the rich and the poor, the extent of poverty and the sharp stratification of society, it is hardly any wonder that slogans about strife and social inequality are so well received among the lower classes in South America. The organisations that are the most successful in combating the establishment are left-leaning political groups, middle-class intellectual groups, the working class and their trade unions, as well as some ethnic minorities which are being discriminated against or even exterminated. These people always harbour the idea of the revolution of the working class, which would bring about a classless society, first on the continent and eventually in the Caribbean and North America as well. This doctrine of a just nation ruled by the working class, the peasants and progressive intellectuals was first brought on to American soil by Leon Trotsky, the second most famous Bolshevik after Lenin. Exiled from Soviet Russia, he came to Mexico in 1937 and remained there until his assassination in August of 1940. Through his labours and the activity of the Comintern, the seed of socialism was planted. Helped along by the ideas imported from Soviet Russia and communist China, the seed bore fruit in the form of, among others, Juan Peron's rule in Argentina, Fidel Castro's revolution in Cuba, the Dominican civil war, the attempt by Salvadore Allende to introduce socialism in Chile, the assumption of power by the Sandinistas in Nicaragua, the leftist coup d'état in Grenada that provoked a US military intervention, a civil war in Peru caused by the Shining Path, a Peruvian militarised Stalinist-Maoist party, a long civil war in Colombia and leftist reforms in Venezuela by Hugo Chavez's government. However, with the exceptions of Cuba and Venezuela, all attempts by left-wing organisations to seize power eventually resulted either in a US military intervention or in the return to the status quo after a clampdown from the right-wing authorities. The leftist organisation learned their lessons well, though, and drew the right conclusions from their miserable failures. Since then, the Bolivarian idea of 'Patria Grande' ('Great Fatherland') has been reborn in South America, only this time supported by a secretive initiative called URSAL (the Union of Latin American Socialist Republics, Spanish União das Repúblicas Socialistas da América Latina).

## **5. THE URSAL PLAN**

It was only in 2018 that details concerning the Ursal Plan have been revealed to the wider public. It happened in Brazil during a televised presidential debate between Cabo Daciolo, the representative of Patriota, a Brazilian right-wing party, and Jair Bolsonaro, a retired military officer and member of the Social Liberal Party. The latter caused social anxiety by revealing the details of the so-called URSAL Plan, ensuring his victory in the elections later in the year. The matter of URSAL is not itself new, however; it was first mentioned in 2001 in an article by a Londrina State University professor Maria Lucia Victor Barbosa (the city of Londrina is located in Brazil, in the state of Paraná). (Barbosa M. L. V., 2001). After the publication, Barbosa became a frequent subject of newspaper articles and guest in television shows. URSAL is also considered a conspiracy theory regarding the socialist takeover of Latin America (URSAL, 2018). According to right-wing and Catholic media in Brazil, the plan refers to a 19<sup>th</sup> century political concept called Patria Grande, related to the idea of integration of Latin America and voiced by the continent's liberators – Simón Bolívar and José de San Martín. It postulated the formation of a single political entity, a federation of all Latin American countries, stretching from Mexico in the north to Argentina and Chile in the south, as well as across all of the Caribbean. The URSAL Plan introduces new elements to Patria Grande. In its first stage, all the Latin America countries would become united, and in the second, a new Communist and anti-Christian nation would be formed.

Private property would be abolished and the conglomerate would be unilaterally ruled by a single party merged from left-wing groups across Latin America. The main axis, as well as the mainstay of the new order, would be Brazil, a dictatorship of the proletariat, and the entire federation would be a bloc of socialist republics (Dossiê URSAL, 2014). Free thought and immoral capitalist influence from without would be stifled, and the newfound nation would have a duty of supporting progressive movements across the world and spreading the idea of social revolution to other continents, peacefully or otherwise.

## 6. CONCLUSION

To Europeans, the plans to create a single great state organism in the west hemisphere are unsurprisingly intriguing. Naturally, Europe's idea of federalism is closer to what the European Union represents rather than what the URSAL plan entails; indeed, our point of view makes it very difficult to make sense out of their attempt to implement solutions which we know have already failed in the USSR and within individual countries of the Eastern Bloc. It may become more understandable, however, if we take into account that fact that the power structures in South America are relatively new and not yet fully fledged; the ubiquitous poverty and social inequality within the region are also important factors increasing Hispanic and Portuguese America's susceptibility to the same ideas which have already become a thing of the past elsewhere. At least one thing is certain: the progressing integration of Latin American countries is undeniable and will result in the creation of a globally influential political and economic force. Whether this integration comes about by the path of right-wing liberalism or left-wing revolution, however, only time will tell.

## LITERATURE:

1. Archived copy (2011), *The Original copy on 2011-06-08*, Retrieved 12/11/2018 from [https://web.archive.org/web/20110608032533/http://www.caricom.org/jsp/speeches/awar\\_dceremony\\_outstandingstudents\\_applewhaite.jsp?null&prnf=1](https://web.archive.org/web/20110608032533/http://www.caricom.org/jsp/speeches/awar_dceremony_outstandingstudents_applewhaite.jsp?null&prnf=1)
2. Bandeira L., (2018), *#ElectionWatch: URSAL, Illuminati, and Brazil's YouTube Subculture*, Digital Forensic Research Laboratory Atlantic Council, Retrieved 16/11/2018 from <https://medium.com/dfrlab/electionwatch-ursal-illuminati-and-brazils-youtube-subculture-56c3a6d5c767>
3. Barbosa M.L.V., (2001), *Os companheiros*, article 09/12/2001, Retrieved 15/11/2018 from <http://www.olavodecarvalho.org/os-companheiros/>
4. Bryk (2018), *Ugrupowania Integracyjne Ameryki Południowej i Środkowej*, Studia, Ekonomia, Pozostałe artykuły, Anonim, Retrieved 09.11.2018 from <https://www.bryk.pl/wypracowania/pozostale/ekonomia/14554-ugrupowania-integracyjne-ameryki-poludniowej-i-srodkowej.html>
5. Burek R., (2000), *Mała Encyklopedia PWN A-Z*, Wydanie III poprawione, p. 897, Wydawnictwo Naukowe PWN SA, Warsaw.
6. De West (2015), *Suriname en Guyana officieel Geassocieerd Lid Mercosur*, Retrieved 10/11/2018 from <http://dagbladwest.com/2015/07/20/suriname-en-guyana-officieel-geassocieerd-lid-mercosur/>
7. Dossiê URSAL, (2014), *URSAL – União das Repúblicas Socialistas da América Latina*, Retrieved 16/11/2018 from <http://www.dossieursal.com/>
8. Garcia M. A., González S., Reza L., Romero M., Salinas A., (2011), *"Three" in Conaliteg; Geografía, Quinto Grado (eng. Geography, Fifth Grade)* pp. 75-83, (second edition). Secretaría de Educación Pública, Mexico City.
9. Horbeek B., (2016), *Brazil's Regional Integration of Latin America: An Analysis of Brazilian Foreign Policy under Lula and Rousseff*, Leiden University, Retrieved 13/11/2018 from: <https://openaccess.leidenuniv.nl/handle/1887/44792>

10. IMF - International Monetary Fund, (2011), Bolivia, Colombia, Ecuador, Peru, Venezuela retrieved 12/11/2018 from <https://www.imf.org/en/Data>
11. International Labour Organisation ILO (2018), News, ILO's annual Labour Overview of Latin America and the Caribbean, Unemployment up for 3rd consecutive year Retrieved 04/11/2018 from [https://www.ilo.org/global/about-the-ilo/newsroom/news/WCMS\\_614165/lang--en/index.htm](https://www.ilo.org/global/about-the-ilo/newsroom/news/WCMS_614165/lang--en/index.htm)
12. Klonsky J., Hansen S., (2009)., *Mercosur: South America's Fractious Trade Bloc. Council on Foreign Relations*, Popular Searches, Retrieved 11/11/2018, from <https://www.cfr.org/publication/12762/>
13. Long N.V., (2014), „Zarządzanie Innowacyjne w Gospodarce i Biznesie“, issue 1 (18), p. 99, Wydawnictwo Akademii Humanistyczno-Ekonomicznej w Łodzi, Łodz.
14. Ludność Ameryki Południowej (2018), *Ameryka Południowa liczba ludności*, Retrieved 04/11/2018 from <https://www.populationof.net/pl/latin-america-and-the-caribbean/>
15. Osmanczyk E., (1974), *Encyklopedia Spraw Międzynarodowych i ONZ*, pp. 318-319 Wydawnictwo Naukowe PWN, Warsaw.
16. Sapeta J., 2016, *Ameryka Łacinska, Nowożytność, Państwo*, Retrieved 06.10.2018, from [http://historia.na6.pl/ameryka\\_lacinska](http://historia.na6.pl/ameryka_lacinska)
17. URSAL (2018), *Part of a series on Communism*, article August 2018, Retrieved 15/11/2018 from <https://knowyourmeme.com/memes/ursal>
18. World Bank (2018), *World Bank national accounts and OECD National Accounts data files* Retrieved 03/11/2018 from <https://data.worldbank.org/region/latin-america-and-caribbean>

## **INFLUENCE ON DECISION-MAKING PROCESS FOR MOBILE MODELS AND PHONE TARIFF OPTIONS: CASE OF CHILDREN POPULATION**

**Diana Plantic Tadic**

*University of Applied Sciences VERN' Trg bana J.Jelačića 3, Zagreb, Croatia  
diana.plantic-tadic@vern.hr*

**Jadranka Ivankovic**

*University of Applied Sciences VERN' Trg bana J.Jelačića 3, Zagreb, Croatia  
jadranka.ivankovic@vern.hr*

**Zrinka Mrkonjic**

*University of Applied Sciences VERN' Trg bana J.Jelačića 3, Zagreb, Croatia  
zrinkamrkonjic@gmail.com*

### **ABSTRACT**

*Consumer behaviour of the twenty-first century is more complex than ever before. Globalisation and digitalisation have shifted the balance of the sales process in the favour of modern consumers. In order to stand out, modern companies must be capable of comprehending all of the aspects of the consumers' environment and anticipate consumers' demands, as well as the approach to be used as part of their integrated marketing communication. In the past twenty years, the mobile phone and telecommunications market has seen immense growth marked by yearly advancements in technology. The market is saturated with a large number of substitutes and the supply greatly exceeds the demand. The emphasis in this paper has been put on studying consumer behaviour, more specifically on the influences involved in choosing a mobile phone and tariff for the population of children. The children of today have come to own mobile phones earlier than ever before and have come to reach levels of technological literacy the likes of which are rarely encountered in adults. As such, they are becoming more and more noticed as a source of influence within the family. The paper summaries results of empirical researches; focus groups and a survey. Researches studied what influences families when it comes to the process of purchasing a mobile phone and a tariff for the population of children. The subjects were children in the age from seven to fourteen years and their parents. Both researches studied what influences families when it comes to the process of purchasing a mobile phone and a tariff for the population of children. The subjects were children between the ages of seven and fourteen and their parents. The research examined the way children use mobile phones, the reasons behind mobile phone usage in children as well as the customer journey of choosing the mobile phone model and tariff option for children. The parents of children who are not active mobile phone users were separated from the parents of children who actively use and own mobile phones. This thesis encompasses all of the factors affecting the process involving the decision of making a purchase and states the conclusions deduced from the research.*

**Keywords:** *Children, Decision making, Mobile phones, Telecommunications tariffs, Consumer behaviour*

### **1. INTRODUCTION**

Consumer behaviour is a new scientific discipline which first came to be during the nineteen-sixties, soon after the beginning of the Marketing Concept Era (Kesić, 2006). The Marketing Concept Era puts emphasis on the analysis of the consumers' desires and necessities. As opposed to the Sales Concept Era, during which the emphasis was more on the sale itself than

on establishing a relationship with the consumer, the Marketing Concept Era was marked by the awareness of the market being saturated by supply. In order to stand out, companies had to have been capable of comprehending all of the aspects of the consumers' environment and anticipated consumers' demands, adapting accordingly. What follows is the Customer Relationship Era, the main characteristic of which is personalisation of goods and services according to the customers' wishes. This trend has not subsided since. The Socially Responsible Marketing Era is mainly defined by corporate social responsibility and it is the last and current marketing era. Its goal is earning profit in a sustainable way. That is, meeting the market needs by earning profit while assuming responsibility for their effect on both the society and the environment. The market of today is also characterised by the processes of globalisation and digitalisation. The information flow is now faster than ever. The internet enables one to search for information regarding products, different offers and companies, prices, product or service quality and other consumers' experiences online in a matter of minutes. Consumers are becoming increasingly more educated and less spatially limited. Relationship-based marketing is becoming a vital element in terms of developing consumer relations. Due to the extensive amount of information they have at their disposal, shoppers have gained leverage over the sellers. However, the abundance of information can also confuse the average shopper. In order to capture shoppers' attention and encourage them to make a purchase, companies must first understand the factors which help form purchasing decisions. In order to be effective, the marketing strategy must stem from understanding the consumers and their decision-making process.

## **2. THEORETICAL DETERMINANTS OF THE PURCHASING DECISION-MAKING PROCESS**

"Consumer behaviour presents the process of acquiring and consuming products, ideas and services. This includes post-sale processes which encompass assessment and post-sale behaviour" (Kesić, 2006, p. 5). The purchasing decision-making process takes place under the influence of a variety of factors which are generally classified in one of three groups: social, personal or psychological factors. Social factors include one's culture, society, socio-economic class, social groups, family and situational factors. One's motives and motivation, perception, attitudes, personality characteristics, values, lifestyle and knowledge constitute personal factors. Lastly, psychological factors consist of processing information, learning, shifts in one's attitude and behaviour, communication within groups and individual influence (Kesić, 2006). The sum of above-mentioned factors represents the prevailing influence which dictates consumer behaviour in terms of the purchasing decision-making process. Put simply, social factors represent reference groups to which the consumer belongs. These groups can have a direct or indirect influence over the consumer depending on whether the consumer belongs to them or not. Reference groups can be divided into primary (family, friends, colleagues or neighbours) and secondary (religious groups or trade unions). Apart from introducing new thoughts and attitudes to an individual, reference groups also exert a certain amount of pressure on an individual in order to force him to behave according to the rules of the said group. The family of a person represents his or hers primary reference group. It is this reference group that holds most sway over the behaviour of a consumer. Parents form a person through upbringing by influencing their child's religious, political, economic and other convictions. Additionally, one's ambitions, self-esteem and personal beliefs are also in part shaped through upbringing. Technological literacy of children is a characteristic of modern families. Children are mastering modern technological skills on their own, thus, becoming influential within their family units. The field consumer behaviour studies, namely, the way in which individuals or groups purchase and use goods, services or experiences for the purpose of satisfying their desires and needs. It is a three-stage process.



The first stage is the one during which factors that influence the choice of product to be purchased are taken into account. The second stage is the stage of consumption and satisfaction or dissatisfaction with what was purchased. This, in turn, impacts the repeat purchase. The last stage is the stage in which the buyer determines what to do with the product he or she consumed (Kesić, 2006). According to the same author (2006, p. 14) “the purchasing decision-making process represents a range of sequential influential happenings and decisions resulting in desired actions.” Consumers do not always go through all of the stages. That is dependant on the complexity of their need. The process begins in the moment of becoming aware of a need which usually comes as a response to an internal or external stimuli. What follows is research of sources in search of information. There are a few distinguishable sources. Personal sources, such as family, friends and colleagues, commercial sources such as advertisements, websites, vendors or product packaging. Lastly, there are public sources such as mass media and experiential sources such as handling a product, research and product usage (Kotler, Keller, Martinović, 2014). To what extent will a certain choice be influential is dependant on the type of product the buyer considers to purchase.

### **3. ANALYSIS OF THE TELECOMMUNICATIONS MARKET IN THE REPUBLIC OF CROATIA**

The mobile phone and mobile phone tariff markets are swiftly progressing on a yearly rate. Once unsurpassable companies such as Apple or Samsung, have to compete with more affordable devices of similar quality. Taking into account afore-mentioned purchase decision-making factors and processes, it is apparent that the process at hand is a complex and dynamic one. Considering the general level of technological literacy in Croatia, as well as the purchasing power of Croatian consumers it is discernible that the telecommunications market has a challenging task. Marketing strategies must be adapted according to the needs and culture of the market while staying in accordance with the core values and culture of the company whose products they are trying to sell. The telecommunications market in the Republic of Croatia is quite small. There are only four mobile carriers in Croatia that offer telephone services in the public mobile communications network. Those carriers are HT d.d., NTH Mobile d.o.o., TELE2 d.o.o. and VIPNet d.o.o. The term telephone services implies the services of mobile and fixed network communications, as well as internet, or rather, data usage. Most mobile phone users vacillate between top-up cards and subscription contracts. When browsing the websites of leading telecommunications companies, it becomes apparent that the differences in their respective offerings are negligible. All three companies, (HT, TELE2, VIPNet), offer comparable packages, neither offering standing out from the rest. Variances can be noticed mostly during the holiday season and sales. That is the time during which companies offer different deals and discounts on individual package deals. HT, (Croatian Telecom), offers four types of subscription contracts, while Vipnet offers three. Besides subscription contracts, both companies offer four types of top-up card based contracts. Other competitors include: Tele2 and less competitive Tomato and Bonbon.<sup>1</sup> According to the research executed by P3 Communications (2016)<sup>2</sup>, all three leading telecommunications companies in Croatia have an index of mobile phone services higher than 800. This ranks them on the very top Europe-wide. The quality of individual services differs by merely 10 units. For the sake of comparison, the gap between the best and worst company in the Netherlands is 52 units. This research suggests that the quality of different service providers is inconsequential.

---

<sup>1</sup> Novac.jutarnji.hr. (24.04.2018). A Review of domestic telecommunications companies: Pros and Cons of pre-paid and post-paid mobile tariff options”. Retrieved (12.09.2018) from: <http://www.poslovnih.hr/vijesti/istrazivanje-koji-mobilni-operater-u-rh-je-najjeftiniji-156431>

<sup>2</sup> Poslovnih.hr. (14.07.2016). Tri telekomunikacijske kompanije u Hrvatskoj odmjerile snage: Tko ima najbolji mobilni internet? Poslovnih.hr. Retrieved 12.09.2018 from: <http://www.poslovnih.hr/tehnologija/ht-vipnet-i-tele2-prvi-put-izjednaceni-po-kvaliteti-315401>

The same research ranks HT, (Croatian Telecom), as the provider with the highest quality of service, Vipnet as second and Tele2 as third best. In accordance with data provided by the HAKOM, (Croatian Post and Electronic Communications Agency), the number of private users of telecommunications services totals at 3.668.869 users, 1.531.144 of which are bound by subscription contracts. The total number of users is constantly rising, as well as the percentage of revenues this industry earns.<sup>3</sup> Continual innovations, as well as technological advances are mainly responsible for the perpetual rise in the number of new end users. Solely by introducing new conditions into tariff options can differentiate a company itself. That is, purely by providing new value for the same price. For example, by offering free data usage for accessing YouTube. Gaining market share in a saturated market is achievable only through creation of new content and creativity.

#### **4. EMPIRICAL RESULTS**

In order to make a marketing decisions, primary and secondary sources are used for the purposes of forming a theoretical framework. Hereafter, the article presents some findings of a two researches conducted upon request of one of the forenamed telecommunications companies. The results are analyzed and discussed with more details in the bachelor's thesis (Mrkonjić, 2018). This paper analyses the influences involved in the decision-making process of choosing a mobile phone model and tariff in the population of children. Initial assumption is that children have considerable influence within the family when it comes to purchasing decisions regarding mobile phone models. In addition, the objective is to determine the the sources of influence on children regarding mobile phone models and tariff options.

##### **4.1. Methodology**

The research was conducted in two phases; qualitative research, through focus groups, and quantitative research with a survey. Four focus group were held, with 19 subjects in total. They were held in two locations (Zagreb and Samobor), in June of 2018. The subjects were children in the age from seven to fourteen years, accompanied by their parents. Children were divided, into 2 groups; children attending 1<sup>st</sup> – 4<sup>th</sup> class of primary school, and children attending 5<sup>th</sup> – 8<sup>th</sup> class. The parents also participated in parts of the discussion, but their answers are separated from those of children. The survey was carried out by online questionnaire during the summer of 2018, ending with 203 respondents, largely from the City and County of Zagreb. All of the participants were parents of children in the age from seven to fourteen years. Considering the type of research and the composition of the sample, the results shown should be regarded not as representative, but rather as indicative.

##### **4.2. Research results**

The research results provide insights in the way children interact and use mobile phones, and the whole customer journey process of purchase a mobile phone device and tariff. „The Customer Journey process represents a sequence of consequent decisions and influences resulting in desired action” (Kesić, 2006. , p. 14). Customer journey is divided in four stages: initial consideration, active evaluation, moment of purchase and post purchase experience. Customer journey, or rather the path to a purchase, is a four-phase process which begins with the awareness phase and ends with the experience and loyalty phase. The findings of the research are classified according to the phases of the customer journey. All participants in focus groups, (19 children), own a mobile phone which they use on a daily basis.

---

<sup>3</sup> Hakom.hr (April, 2018). Quarterly comparative data of the electronic communication market in the Republic of Croatia. Hakom. Retrieved 12.09.2018 from: [https://www.hakom.hr/UserDocsImages/2018/e\\_trziste/Tromjese%20usporedni%20podatci%20za%20tr%20C5%BEi%20A1te%20elektroni%20ko%20municacija%20RHQ22018.pdf](https://www.hakom.hr/UserDocsImages/2018/e_trziste/Tromjese%20usporedni%20podatci%20za%20tr%20C5%BEi%20A1te%20elektroni%20ko%20municacija%20RHQ22018.pdf)

Smartphone is the prevalent model. Most children received their first device between the first and third grade of primary school. Six out of nineteen subjects currently own a new device, while the rest have inherited their devices from parents or siblings. Excluding one, all of the parents confirmed that their children received smartphones as their first mobile phones. Mobile phones are typically purchased for children upon starting primary school. First devices were customarily inherited passed down by parents or siblings. New devices are usually bestowed upon the eldest child, while the younger siblings inherit pre-owned devices. Between one and three gadgets have been shifted up until that point by all of the children, most of the devices having been bought by their parents.

#### 4.2.1. 1. Stage – Initial Consideration

The main reasons of mobile phone usage among children are; accessing YouTube and other social media websites, playing games, browsing information and communicating with parents. Smartphones play an integral role when it comes to children fitting into peer groups and communicating with their peers. Parents are usually contacted through voice calls, while friends are texted using messenger applications instead of conventional text messages. Mobile phones are most often used during children's spare time. Younger children are ordinarily not allowed to bring their devices to school, while elder children may carry it to school. Contact amongst friends and playing videogames are the main purpose of usage of mobile phones in younger children, hence the rule.

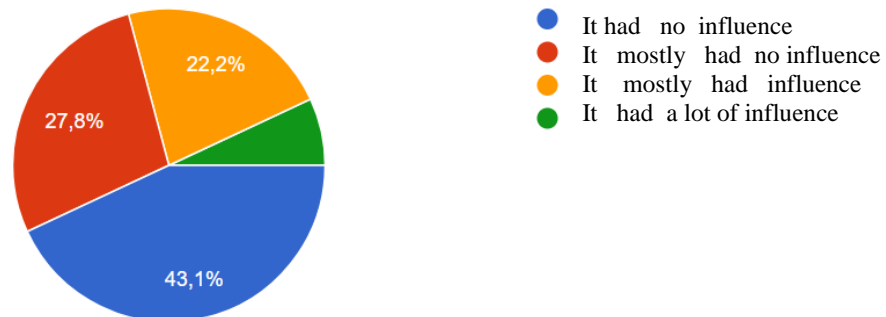

Figure 1: How much did the fact that the friends of your children own a mobile phone influence your decision to purchase one for your child? (Mrkonjić, Z. 2018)

According to the parents, the advantage of a children's mobile phone usage is communication or contact with them any time, any where, accessibility of information, effortless location of children and technological literacy. An important aspect for parents is that child fits in social surroundings. As the prevalent negative aspect parents mentioned too much time spent on mobile phones usage. Among other negative impacts, parents mentioned; undesired contacts outside the family and friends; access to inappropriate content and cyberbullying. On the topic of peers and aspects of privacy, all of the children's companions possess mobile phones. Ownership of a mobile phone is a crucial factor when it comes to assimilation of a child. No child wants to share its device. Children want privacy; they do not want anything to be sent in their behalf, or that anyone has access to their personal messages. Concerning social media sites and content consumption control, Instagram, Facebook, YouTube and Snapchat, in that order, are the most often used social media sites. Parents worry that their children are not mature, educated and responsible enough to handle information and access social media, which they also point out as the most important negative aspects of child mobile phone usage. According to parents, children started requesting mobile phones at a fairly young age.

If an older sibling, or a friend owned a phone, the child without the device naturally wanted one as well. Being able to communicate with friends and staying on-trend with Instagram, messenger and other applications is what made smartphones desirable among children. Without a smartphone, a child can not equally participate in play or communication, which is the main reason why children begin asking parents to get a smartphone. Most frequently, the desire appears upon starting primary school.

#### 4.2.2. 2. Stage – Active Evaluation

Three of the older children propose mobile phone models to their parents, thus impacting parental decisions in terms of choosing a model. The rest of the participants do not suggest different phone models, nor do they accompany their parents to the store. Older participants tend to be more knowledgeable about smartphone specifications, therefore earning parents' trust. Parents admit they take their childrens' suggestions and opinions into consideration.

Figure 2: Who chooses the tariff for the child? (Mrkonjić, Z. 2018)

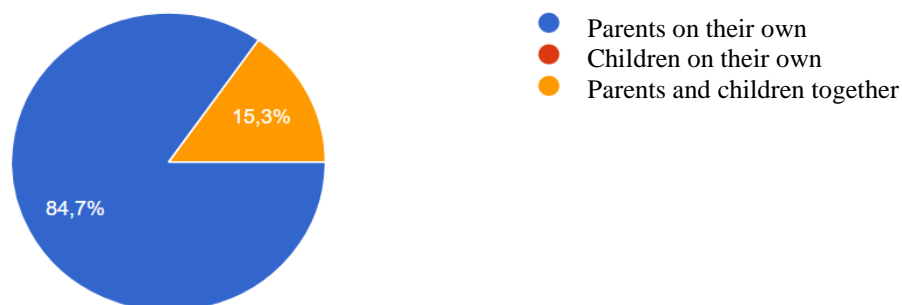

Subjects inform themselves of new models by way of telecommercial, as well as hearing about them from parents and influencers they follow on social media. They claim to be aware that the YouTube influencers they follow are paid to promote various models to them, yet still trust these paid reviews; they believe that the influencers are sincere. Browsing the website of the telecommunication company they themselves use is the preferred method of informing themselves of new mobile phone models.

Figure 3: What was your source of information regarding mobile phone models and tariff options for your child? (Mrkonjić, Z. 2018)

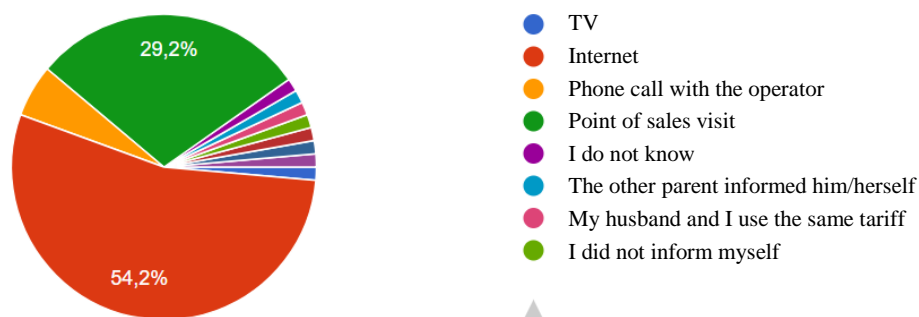

Should the wishes of children regarding specific mobile phone models and tariffs overlap with the budget already determined by the parents, nearly all parents will comply.

#### *4.2.3. 3. Stage - Moment of Purchase*

The buying phase begins with the selection of tariffs: subscription or vouchers. Devices are mostly purchased in the contract of a pre-paid package, only two are using vouchers. Parents usually included children's mobiles in the family tariff or choose the appropriate tariff from the operator they have already used. Parents are willing to switch from their teleoperator for a lower price of data transfer, or more gigabytes for the same amount. When children exceed their tariff, additional gigabytes of data or extra minutes are paid by parents, but usually after a few days. Two thirds of the children exceed limits on monthly basis because of used gigabytes. They often overspend gigabytes because of downloading mobile applications and playing games. Instagram, YouTube, Facebook and Snapchat are the most used social media sites. Children prefer to use messenger applications Viber and WhatsApp and use conventional text messages only when internet turnover is spent.

#### *4.2.4. 4. Stage – Post Purchase Experience*

Playing games, following trends and being able to communicate with friends are the most important reasons for children to have mobile phones. Children spend most of the time watching YouTube videos, playing smartphone games and communicating with friends via messengers. Therefore, parents choose the tariff which offers the most gigabytes and free minutes (being able to contact their child at all times is highly important to the parents). Parents tend to select a tariff from the company they currently use, rather than switching to a new tariff; unless there are major benefits in value for money. Websites are the primary source of information regarding tariffs, while point of sales tend to be the secondary choice. Some parents make a contact with the companies by a phone call. Most children are not controlled by their parents during the time in which they use their phones. Some parents check their children's phones afterwards to see which apps they have used. Merely one father uses an application with which he sets limits on his daughter phone regarding the amount of data and time she can spend using her phone, as well as shows her browsing history. Value may be added to tariffs by including an app which would show the parents how much data the child is using up and also the websites browsed and applications used by the child. Unlimited access to sites using most data, such as YouTube, or a complimentary application that allows streaming music (excluding video data); as well as additional security against cyberbullies and online predators are all ways of adding value to tariffs according to parents' statements.

## **5. CONCLUSION**

Taking into account the presented research results, the following conclusion remarks could be added:

1. All of the children who participated in the focus groups used a smartphone and had more than one model. They usually got first device when came to primary school. The majority of younger children (1<sup>st</sup> – 4<sup>th</sup> class) inherit phones from their parents or siblings, while older children (5<sup>th</sup> – 8<sup>th</sup> class) typically receive new mobile phones.
2. Children used phones on a daily basis for; access to YouTube, Instagram, Snapchat and media, along with playing smartphone games and texting using messenger such as WhatsApp or Viber. Taking mobile phones to school is not allowed for the younger children, while older children are exempt from this rule.
3. For children is important to have smartphone due to its specifications which enable download of mobile applications and games. Other than enabling communication, mobile phones also aid children in the process of forming companionship. Children want to fit in

and be able to discuss trends and participate in multiplayer games. Therefore, most children demand and receive their first phones fairly early on.

4. Parents are concerned about the safety of their children, while they regard ease of communication to be a positive aspect of mobile phone usage.
5. Biggest challenge about safety of children for the parents are; cyberbullying, inappropriate content, unwanted content, as well as possibility of being able to better control the amount of time and quality of content consumed by children. Applications that could address these challenges should be included as a complimentary component of children's tariffs.
6. Children find out about new mobile phone models from YouTube or friends and family members, but their influence on purchasing decision is limited. Usually, parents choose several acceptable models, and then give the children to pick among them. Children already tried more than one model of mobile phones.
7. The majority of mobile phones are acquired through package deals offered as part of a subscription contract. Only a few use top-up cards. Gigabytes are regarded as being the most important aspect of every tariff, while some parents mention unlimited minutes as well. Parents select children's tariffs in accordance with their needs and behaviour habits which almost always include: internet surfing and texting which entails data usage. Parents inform themselves primarily by visiting websites or visiting point of sale. Parents often choose a tariff for their child at the same company they are users of, or they choose the company offering the best value for money. Data is the key component emphasised by both parents and children.

Consequently, there are some recommendations for improving marketing offer of telecommunications companies;

1. Develop websites in order to make them more transparent and interesting for influencers but also easy to handle and informative for parents. Attention should be paid to influencers who have authority in spreading new information regarding mobile phone models and tariffs.
2. Offer more diverse tariffs, thereby including enough data and reducing minutes and texts for new consumer segment.
3. Data usages (gigabytes) are the key aspect of tariffs, eclipsing both conventional calls and text messages. Therefore, a tariff with more data and less minutes might prove to be an appealing offer for children.
4. Children spend a lot of time on social media and messenger applications. Social media marketing should be taken advantage of in order to spread awareness and attract traffic to websites.

#### **LITERATURE:**

1. Hakom.hr (April, 2018). *Quarterly comparative data of the electronic communication market in the Republic of Croatia*. Hakom. Retrieved 12.09.2018 from: [https://www.hakom.hr/UserDocsImages/2018/e\\_trziste/Tromjese%C4%8Dni%20usporadni%20podatci%20za%20tr%C5%BEi%C5%A1te%20elektroni%C4%8Dkih%20komunikacija%20RHQ22018.pdf](https://www.hakom.hr/UserDocsImages/2018/e_trziste/Tromjese%C4%8Dni%20usporadni%20podatci%20za%20tr%C5%BEi%C5%A1te%20elektroni%C4%8Dkih%20komunikacija%20RHQ22018.pdf)
2. Kesić, T. (2006). *Ponašanje potrošača* (2.nd Ed). Zagreb: Opinion d.o.o
3. Kotler, P., Keller K.L., Martinović, M. (2014). *Upravljanje marketingom*. Zagreb: MATE d.o.o.
4. Mrkonjić, Z. (2018.). *Influences involved in the decision-making process regarding mobile phone models and tariff options in the population of children*. Vern' University of Applied Sciences, Zagreb.

5. Novac.jutarnji.hr. (24.04.2018). *Pregled domaćih teleoperatera: Prednosti i mane prepaid i postpaid mobilnih tarifa*. Novac.hr. Retrieved 12.09.2018 from: <https://novac.jutarnji.hr/novcanik/pregled-domacih-teleoperatera-prednosti-i-mane-prepaid-i-postpaid-mobilnih-tarifa/7271955/>
6. Poslovni.hr. (27.08.2010). *Istraživanje: Koji mobilni operater u RH je najjeftiniji?* Poslovni.hr. Retrieved 12.09.2018 from: <http://www.poslovni.hr/vijesti/istrazivanje-koji-mobilni-operater-u-rh-je-najjeftiniji-156431>
7. Poslovni.hr. (14.07.2016). *Tri telekomunikacijske kompanije u Hrvatskoj odmjerile snage: Tko ima najbolji mobilni internet?* Poslovni.hr. Retrieved 12.09.2018 from: <http://www.poslovni.hr/tehnologija/ht-vipnet-i-tele2-prvi-put-izjednaceni-po-kvaliteti-315401>

## THE DECISION-MAKING ON INVESTMENT IN INDUSTRIAL ENTERPRISES – CASE STUDY

**Eva Malichova**

*University of Zilina, Faculty of Management Science and Informatics, Slovakia*  
*eva.malichova@fri.uniza.sk*

### **ABSTRACT**

*The article focuses on the analysis of the process of investment decision-making in two medium-sized industrial enterprises and on the comparison of these processes. The pieces of information were gathered via personal interviews with the managers of the enterprises, and they were compared with the results from the questionnaire survey conducted among other industrial medium-sized enterprises operating in the Slovak Republic. The enterprises start the process of investment decision-making with the identification of a problem, and then proceed to the definition of variants, assessment of these variants, and the subsequent selection of the optimal one. The substantial criteria during the assessment are represented by the amount and return on investment but also by qualitative criteria, such as the impacts of the investment on the quality of products, or the previous experience. The enterprises acquire the information on opportunities in the market or on possible investment variants from various sources but mainly from the solutions of their competitors, trade fairs, customers, and from their employees. Even though the analysed enterprises belong among the efficient ones in relation to their investment process, they do not use the methods of appraisal of economic efficiency of investment during the assessment of investment variants, or they use them only to a low degree. Mainly, the amount of investment is important for them. The absence of these methods of appraisal is directly connected to the absence of analysis and quantification of risk of investment problems. The results of comparison of processes of investment decision-making in enterprises shall contribute to the identification of those factors that can make the investment process more efficient and inspire these enterprises to implement them.*

**Keywords:** *Investment, Investment decision process, Industrial enterprises, Comparison, Medium sized enterprises*

### **1. INTRODUCTION**

The decision-making on investment plays a very important role in industrial enterprises. The industrial enterprises belong to those performing the decision-making on investment the most often, regarding the production process, utilisation of the machines, continuous improvement of new technology, and so on. In the industrial enterprises, the performing of the decision-making is connected to the spending of a huge amount of funds on the fixed assets which shall bring benefit for the enterprise in the future. This benefit has a significant influence on the generation of value in the enterprise and the wealth for the owners (Afonso, 2009). On the other hand, the long-term nature of the investment projects, and the fact that they are so demanding on the financial resources, represent a risk for the enterprises. This risk is being increased also in relation to the dynamic environment in the market leading to the continuously changing conditions for the decision-making process. The decision-making on investment, regarding its essence, is very difficult and the process itself has not been standardized yet (Wöhrmann, 2017). The decision-making on investment in industrial enterprises therefore represents a demanding activity, since the selection of the right investment variant encompasses detailed knowledge of the enterprise's current state, determination of investment possibilities, their appraisal based on specific criteria significant for the enterprise, and the subsequent selection itself. From the enterprise point of view, we can describe the investment as the spending of enterprise's funds with the purpose of increase of its revenues in the future.



Ďurišová defines the enterprise's investment as a process of allocation of financial resources in its asset components (Ďurišová, 2013). The investments themselves can then be defined as the financial or other resources spent with the aim to get gains in the future (Brealey et al. 2011; Bodie, 2008; Bierman – Smidt, 2012). This future gain will contribute to the acquisition of other funds (Scholleová, 2000; Jeon, 2014; Pogue, 2010). Ďurišová (2013) defines the investments from the enterprise perspective as "the decision on the allocation of capital, respecting its return and appreciation". Another enterprise characterization of investments focuses on the definition of investments as the asset not dedicated for the consumption but for the generation of other assets with which the enterprise conducts business. Crosson and Needles (2008) define the investment decision-making as the process of making decisions on investments in capital, while they define the steps of this decision-making as: analysis of requirements, preparation of materials for the managers, selection of optimal variant, and allocation of funds according to the needs. Gotze et al (2015) identified the following parts of the investment decision-making: developing capital investment strategy, generating investment ideas, defining and presenting possible projects, screening projects, analysing projects (investing, not investing), implementing the selected projects, and monitoring and post-auditing the projects. Fotr et al. (2006) divide the process into three phases: the pre-investment one, investment one, and the operating one. Scholleová (2000) adds two more to these three phases. One of them is the de-investment focused on the ending of operation with the lowest costs possible, and the second one is the post-investment audit, which shall serve for the improvement and better decision-making and management of other investment projects. A substantial element of the investment process is the appraisal and selection of the optimal variant. The investment appraisal can be defined as the decision on whether to spend the funds on the procurement of assets, in which the benefits and costs related to the investment are being compared (Mott, 2008). Ďurišová (2013) defines four steps of appraisal of the investment being prepared: determination of the need of capital expenditures of the investment; determination of costs on capital; estimation of future net monetary revenues, which the investment will bring, and the risks connected to these revenues; and the appraisal of economic efficiency of the investment project. An insufficient appraisal of economic efficiency of investments in enterprises can contribute to their problems with the realisation of these investments. The process of investment decision-making, as described above, is closely related to the criteria used for the appraisal and selection of investment variants. Scholleová et al. (2010) divide the appraisal criteria into static and dynamic ones, according to the methods used for their calculation and the fact whether these methods take into account the time value of money and various sources of risk related to investment. Samset and Christensen (2017) add that the initial investment appraisal should use the same set of criteria that will be used later when assessing the investment's success ex post. The step of ex post assessment serves for the learning and improvement of future decisions. Frank et al. (2013) tried to offer a whole framework for the investment decision-making. The authors focused this framework on the investments such as the selection of manufacturing equipment, technology or product portfolio. Their framework combines several well-known methods (SWOT analysis, quality function deployment, Net Present Value and the Payback period) to assure that different aspects are considered while making a decision that can affect the enterprise's success and operation from a long-term perspective. In relation to the investment decision-making, Schlegel et. al (2016) researched the situation of German manufacturing enterprises. They revealed, for example, that the size of enterprises was an important factor and the smaller enterprises tended to use single-period methods in contrast with the larger ones preferring the multi-period methods. A research conducted in Poland (Wnuk-Pel, 2013), also focused on manufacturing enterprises, showed similar findings.

The enterprise's size significantly influenced the investment appraisal methods and criteria where only the larger enterprises used discounted cash flows and sophisticated risk evaluation methods.

## **2. METHODOLOGY**

The aim of this article is to perform a comparison of two approaches to the process of decision-making on investment in medium-sized industrial enterprises operating in the area of the Slovak Republic. This case study is a part of the research focused on the managerial decision-making on investment in medium-sized enterprises in Slovakia. The research deals with the identification of the substantial elements, activities, tools and methods used in the process of decision-making on investment in enterprises that make efficient investment decisions, while they are being compared to the enterprises whose decisions are inefficient. The research was conducted in industrial and IT enterprises. The purpose of selection of two different sectors was the revealing whether the process of decision-making differs in relation to the object of enterprise's activity. For the needs of this article, two industrial enterprises were selected, in which the current state of the process of investment decision-making was compared. The industrial enterprises were selected regarding the frequent performing of the process of investment decision-making. The pieces of information on the enterprises were gained via the application of content analysis of the information sources available, which include the financial statements, internal standards, and annual reports. These were supplemented with the data gained via a questionnaire focused on the investment decision-making, which was a part of the survey performed in 148 enterprises. And finally, the data were gained also from the interviews conducted in these enterprises. The personal interviews were chosen mainly for their ability to provide valid and reliable data (Saunders, 2009), and the ability to reveal the information that cannot be covered by the questionnaire. The interviews were conducted during personal visits directly in the enterprises. The interviews were semi-structured, and they shall bring the answers for the following questions:

- What activities create the current process of investment decision-making in an enterprise?
- What are the triggers of the process of investment decision-making?
- How does an enterprise identify variants for the achievement of the process's goal?
- Which methods of the appraisal of economic efficiency of the investment variants does an enterprise use?
- What factors (internal, external) influence the process of investment decision-making?

During the interviews, it was also possible to apply the method of observation, which served for the gaining of information from the personal communication and the reactions of enterprises' chief executive officers. Regarding the nature of such information, the processing was done via the methods of qualitative assessment. This is based on the enterprise documents available, questionnaires, and the records from the meetings in the enterprises. For the needs of this article, the method of comparison was applied as well. It was applied to compare the information from the documents, questionnaires and interviews between the enterprises studied.

## **3. THE COMPARISON OF INVESTMENT DECISION-MAKING IN ENTERPRISES**

Since the research focused on the investment decision-making in enterprises was oriented on the medium-sized enterprises with the number of employees below 250, the enterprises studied in this article belong to this group as well. Both enterprises have the legal form of the limited liability company, and they are owned by a domestic owner. The first one (Enterprise A) is focused on the production of labels and packages for the beverage and food industry where it belongs to significant producers of labels for the market of Central and Western Europe. In Table 1, there are the indicators listed, showing the fixed assets of the enterprise, the revenues,

and the profit. As it can be seen here, during the last four years, the enterprise was able to achieve the revenues ranging from 11 to almost 14.3 million Euros, which was then reflected in the mildly decreasing profit. Regarding the assets, the enterprise owns mainly the fixed tangible assets consisting of land, structures (four manufacturing halls, warehouse space) and the individual movable assets, which in this enterprise include mainly the printing equipment, cutting equipment, and others. The enterprise also owns intangible assets that consist of various software products, since the enterprise has its own graphics department and own information systems.

*Table 1: Basic accounting data on the Enterprise A*

<b>Enterprise</b>	<b>Enterprise A</b>			
<b>Type of asset /Year</b>	2017	2016	2015	2014
<b>Non-current assets</b>	<b>3 249 556</b>	<b>3 711 077</b>	<b>4 438 562</b>	<b>4 943 900</b>
<b>Non-current intangible assets</b>	<b>95 327</b>	<b>64 692</b>	<b>50 368</b>	<b>40 545</b>
<b>Software</b>	15 337	31 042	50 368	40 545
<b>Valuable rights</b>				
<b>Acquisition of non-current intangible assets</b>	79 990	33 650		
<b>Property, plant and equipment</b>	<b>3 154 229</b>	<b>3 646 385</b>	<b>4 388 194</b>	<b>4 903 355</b>
<b>Land</b>	123 791	123 791	123 791	123 791
<b>Structures</b>	1 021 658	1 128 063	1 202 131	1 292 041
<b>Individual movable assets and sets of movable assets</b>	1 998 053	1 863 419	2 615 314	3 476 796
<b>Acquisition of property, plant and equipment</b>	9 727	45 403	22 647	9 727
<b>Advance payments made for property, plant and equipment</b>	1 000	485 709	424 311	1 000
<b>Revenues</b>	<b>12 658 304</b>	<b>11 938 510</b>	<b>14 259 532</b>	<b>13 339 351</b>
<b>EBITDA</b>	<b>1 096 155</b>	<b>1 202 667</b>	<b>1 292 114</b>	<b>1 523 090</b>
<b>EBIT</b>	<b>194 823</b>	<b>218 635</b>	<b>262 684</b>	<b>307 102</b>

In 2017, the enterprise spent 439 thousand Euros on the investment in the non-current assets, where 389 thousand Euros were spent on the purchase of new production equipment, 4 thousand Euros on software, and 46 thousand Euros on the upgrade of the information system. Since the enterprise from its establishment performed the investment decision-making almost every year, during the building of production halls or the purchase of production equipment, it has sufficient experience within this area. The interview was conducted with the chief financial officer of the enterprise who is also the enterprise's owner. The trigger of the investment process in the enterprise is mainly the seizing of an opportunity in the market, followed by the change of production equipment. The CFO considers the opportunities in the market to be represented mainly by new technology and materials, which are very important for the enterprise. New pieces of information regarding the technology are gained via the participation in trade fairs and via the monitoring of development of printing machines. A substantial factor is also represented by the customers. Their new requirements push the enterprise into application of new technology and possibilities within the field of production. The enterprise identifies new opportunities also via benchmarking, where it tries to compare itself with its competitors. Such comparison contributes to the identification of variants of solution within the process of decision-making on investment. Subsequently, the enterprise assesses the investment projects if it identifies more than one. Important criteria for the assessment are represented mainly by the amount of investment, the level of risk of the investment, previous experience with the type of investment or the suppliers, and also the impacts of individual variants on the enterprise's

products. For the purchase of production equipment, the technological level of this equipment is important. The enterprise does not focus on the appraisal of economic efficiency of investments, the indicators of return are calculated only in some of the cases. When the enterprise wanted to realise larger investment, it calculated the Net Present Value as an auxiliary indicator required by the bank, together with the sensitivity analysis as a method for the risk analysis of the investment variant. In the enterprise, mainly the following factors are considered significant in their impact on the investment process: customers, development in the market, new technology, and the level of information. The owners, also performing the roles of chief officers, together with economists and technology specialists responsible for the production participate in the process of decision-making in the enterprise. However, the decision-making itself is performed only by the owners – the chief officers. The second enterprise (Enterprise B) is focused on the production of measuring devices. In this enterprise, the managers are continuously trying to implement innovations and expand the production, which causes often cases of investment decision-making. In Table 2, there are the basic accounting data for the previous accounting periods.

*Table 2: Basic accounting data on the Enterprise B*

Enterprise	Enterprise B			
Type of asset /Year	2017	2016	2015	2014
<b>Non-current assets</b>	<b>1 199 766</b>	<b>1 224 179</b>	<b>1 263 291</b>	<b>1 265 947</b>
<b>Non-current intangible assets</b>	<b>13 130</b>	<b>5 043</b>	<b>3 051</b>	<b>5 331</b>
<b>Software</b>	9 764	1 281	3 051	5 331
<b>Valuable rights</b>	3 366	3 762		
<b>Property, plant and equipment</b>	<b>1 186 636</b>	<b>1 219 136</b>	<b>1 260 240</b>	<b>1 260 616</b>
<b>Land</b>	300 000	300 000	300 000	300 000
<b>Structures</b>	699 980	719 984	739 988	759 992
<b>Individual movable assets and sets of movable assets</b>	86 764	169 152	220 252	200 624
<b>Acquisition of property, plant and equipment</b>	99 892	30 000		
<b>Revenues</b>	<b>5 084 871</b>	<b>5 223 597</b>	<b>7 920 226</b>	<b>5 215 807</b>
<b>EBITDA</b>	<b>242 674</b>	<b>171 637</b>	<b>417 785</b>	<b>676 644</b>
<b>EBIT</b>	<b>138 090</b>	<b>61 285</b>	<b>316 634</b>	<b>580 481</b>

The fixed assets of the enterprise consist mainly of the structures – production halls and administration buildings, land, production equipment and software products. The revenues for the year 2017 in comparison with the previous year mildly dropped, however, the profit rose, which means that the enterprise lowered its costs during this period. The personal interview was conducted with the chief officer for production and trade in the enterprise. The investment decision-making process in the enterprise is triggered mainly by the customers' requirements. The enterprise is continuously trying to expand its field of business, and to seize opportunities in the market this way, which contributes to the realisation of investment projects. In addition, the enterprise has always the funds dedicated to the investment beforehand, which it tries to efficiently use throughout the year. The enterprise is also monitoring the wear and tear of its production equipment and based on this it can trigger the process of investment decision-making. However, the higher level of management in this enterprise see the renewal of machinery to be rather a routine. The trigger of the process in the enterprise can also come from the employees that participate in the meetings once a week with the middle management, or they can address their observations to their immediate superiors. The owner, top managers and some selected employees (e.g. economists, technical employees) participate in the process of investment decision-making, but the selection of the variant itself is being performed by the

owner, after consulting with the managers. The main factors that are being considered in the enterprise while assessing individual investment variants include the return on investment, where the enterprise also takes into account the costs related to employees, the impact on the quality of products and processes, and the concordance with the direction and strategy and with the enterprise's reputation. While appraising the economic efficiency of the investments, the enterprise focuses only on the calculation of the return on investment and it does not use any other indicators. During the process of investment decision-making, the risk is defined only via verbal characteristics and to a very limited extend. A very interesting finding is that in the case when the enterprise is interested in the realisation of a large investment, it uses the services of companies that can help with the analysis, appraisal of economic efficiency of the investment, as well as with the evaluation of risks. The Table 3 shows the comparison of the studied enterprises for the individual areas of investment decision-making, together with the results of the survey conducted among industrial enterprises.

*Table 3: Comparison of enterprises and the results from the survey*

	<b>Enterprise A</b>	<b>Enterprise B</b>	<b>Industrial enterprises - survey</b>
<b>Triggers of the process</b>	<ul style="list-style-type: none"> <li>- Seizing an opportunity in the market</li> <li>- Wear and tear of the machinery</li> <li>- Customers' requirements</li> </ul>	<ul style="list-style-type: none"> <li>- Customers' requirements</li> <li>- Wear and tear of the machinery</li> <li>- Employees' ideas</li> </ul>	<ul style="list-style-type: none"> <li>- Seizing an opportunity in the market</li> <li>- Necessity (worn-out machines)</li> </ul>
<b>Generation of variants</b>	<ul style="list-style-type: none"> <li>- Competitors' solutions</li> </ul>		<ul style="list-style-type: none"> <li>- Intuitive ideas</li> <li>- Competitors' solutions</li> <li>- Previous solutions</li> </ul>
<b>Appraisal criteria</b>		<ul style="list-style-type: none"> <li>- Return on investment</li> <li>- Impact on the quality of products, processes</li> <li>- Concordance with the strategy</li> <li>- Enterprise's reputation</li> </ul>	<ul style="list-style-type: none"> <li>- Amount of investment</li> <li>- Payback period</li> <li>- Impact on the quality of products, processes</li> <li>- Previous experience</li> </ul>
<b>Methods of the appraisal of economic efficiency</b>		<ul style="list-style-type: none"> <li>- Indicators of return</li> </ul>	<ul style="list-style-type: none"> <li>- Indicators of return</li> <li>- Payback period</li> <li>- Net Present Value</li> </ul>
<b>Risk evaluation</b>		<ul style="list-style-type: none"> <li>- Verbal</li> </ul>	<ul style="list-style-type: none"> <li>- Verbal characteristics</li> <li>- Numeric characteristics</li> </ul>
<b>Factors affecting the process</b>		<ul style="list-style-type: none"> <li>- Economic situation of the enterprise</li> <li>- Owners' requirements</li> <li>- Customers</li> <li>- New technology</li> <li>- Level of information</li> </ul>	<ul style="list-style-type: none"> <li>- Economic situation</li> <li>- Owners' requirements</li> <li>- Customers</li> <li>- New technology</li> </ul>
<b>Participants in the process</b>	<ul style="list-style-type: none"> <li>- Owners</li> <li>- Chief officers</li> <li>- Economists</li> <li>- Technology specialists</li> </ul>	<ul style="list-style-type: none"> <li>- Owner</li> <li>- Higher management</li> <li>- Selected employees</li> </ul>	<ul style="list-style-type: none"> <li>- Managers</li> <li>- Owners</li> <li>- Economists</li> </ul>

Both enterprises belong among those successful ones within the investment decision-making and they consider their investment decisions to be the right ones. When we compare the substantial elements of investment decision-making in these enterprises, it can be observed that

the triggers of the process are similar, but the Enterprise B also focuses on the suggestions from the employees. During the assessment of variants, the enterprises focus mainly on the impacts on products and processes, the amount of an investment, and the payback period, which was corroborated also via the survey in 99 industrial medium-sized enterprises. A very interesting finding is that even though the enterprises belong among those successful ones, they do not pay much attention to the appraisal of economic efficiency of investments. The Enterprise A does not regularly use any of the methods for the appraisal of economic efficiency, and the Enterprise B uses only the traditional indicators of return. In the survey it was revealed that also the other enterprises use mainly the traditional methods of appraisal, and the application of a dynamic method, such as the Net Present Value, was very frequent among the enterprises too.

#### 4. CONCLUSION

Based on the comparison of two processes of investment decision-making in industrial enterprises that perform this process efficiently, it can be stated that the investment decision-making in these enterprises does not differ significantly. However, some elements identified in one enterprise could contribute to the improvement of the decision-making process in the other one, and vice versa. An example is the use of ideas of employees as a trigger for the process of investment decision-making in the Enterprise B, and the implementation of such process of communication with the employees in the enterprise. A very positive finding is that the financial criteria of investment projects are not the main decisive aspect, but the enterprises still more and more focus on qualitative indicators, such as the impact on products, enterprise's reputation, or the concordance with the strategy. On the other hand, the absence of appraisal of economic efficiency of investments is serious because the enterprises cannot assess the economic benefit for them and identify the possible risks connected to the investment. In addition, there is another interesting finding represented by the fact that the enterprises realise the impact of new technology, and they strive for the continuous application of this technology in their production, which they consider to be a substantial factor for the increase of their competitiveness. Since the enterprises are a part of the information society, they also put an emphasis on the level of information for the process of investment decision-making.

#### LITERATURE:

1. Afonso, P., Cunha, J. (2009). Determinants of the use of capital investment appraisal methods: evidence from the field. *The 2009 European Applied Business Research Conference*. Prague.
2. Bierman, Jr. H., Smidt, S. (2012). *The capital budgeting decision: economic analysis of investment projects* (1<sup>st</sup> edition). Routledge.
3. Bodie, Z., Kane, A., Marcus, A.J. (2008). *Essentials of Investments*. New York: McGraw-Hill.
4. Brealey, A.R., Myers, S. C., Allen, F. (2011). *Principles of Corporate Finance*. New York: McGraw-Hill.
5. Crosson, S., Needles, B. (2008). *Managerial Accounting* (8th edition). Boston: Houghton Miffling company.
6. Götze, U., Northcott, D., Schuster, P. (2015). *Investment Appraisal: Methods and Models* (2<sup>nd</sup> edition). Berlin: Springer.
7. Ďurišová, M. (2013). Managerial decision-making on capital investment [In Slovak: Manažérske rozhodovanie o investíciách do dlhodobého hmotného majetku.] In *Scientific papers of the University of Pardubice* : Faculty of economics and administration. Vol. 20, No. 29 (4/2013), p. 37-46.

8. Frank, A. G., Souza de Souza, D. V., Ribeiro, J. L. D., Echeveste, M. E. (2013). A framework for decision-making in investment alternatives selection. *International Journal of Production Research* 51(19), p. 5866-5883.
9. Jeon, H., Nishihara, M. (2014). Macroeconomic conditions and a firms investment decisions. In *Finance Research Letters* 11, 2014. p. 398-409.
10. Pogue, M. (2010). *Investment Decisions: Principles and Practice*. Business Expert Press.
11. Samset, K., Christensen, T. (2017). Ex Ante Project Evaluation and the Complexity of Early Decision-Making. *Public Organiz. Rev.* 17, p. 1–17.
12. Schlegel, D., Frank, F., Britzelmaier, B. (2016). Investment Decisions and Capital Budgeting Practices in German Manufacturing Companies. *International Journal of Business and Globalisation* 16(1). pp. 66-78
13. Scholleová, H. (2000). *Investment controlling [In Czech: Investiční controlling]*. Praha: Grada Publishing.
14. Scholleová, H., Švecová, L., Fotr, J. 2010. Criteria for the evaluation and selection of capital projects. *Intellectual Economics* 1(7), p. 48–54.
15. Wnuk-Pel, T. (2013). Capital Budgeting Practices in Non-manufacturing Companies In Poland. *Social Sciences*. Vol. 4 (82),
16. Wöhrmann, J. (2017). *The investment process*. Equity Markets in Transition. Springer.

# STAKEHOLDER COLLABORATION: IMPLICATIONS FOR IMPROVING TOURIST DESTINATION MARKETING ACTIVITIES

**Marina Perisic Prodan**

*University of Rijeka, Faculty of Tourism and Hospitality Management, Croatia  
marinap@fthm.hr*

## **ABSTRACT**

*In order to establish a high quality tourist experience and create the ideal destination product, it is important to ensure a good collaboration between stakeholders, especially among hotel businesses and tourist boards, as well as to coordinate their marketing activities. The aim of this paper is to research the attitudes on stakeholder collaboration in the process of planning and executing the marketing activities of a tourist destination. Empirical research was conducted on hotel businesses and tourist boards in the Primorje-Gorski Kotar and Istria Counties. This empirical study provides useful insights into the nature of collaboration between stakeholders in conducting marketing activities in the most developed tourist regions in the Republic of Croatia. This research resulted in useful implications for marketing management of hotel businesses and tourist boards in order to contribute to improving the quality of the tourist offer and thus respond to the challenges imposed by modern tourism. Management of hotel businesses and tourist boards should primarily collaborate regarding strategic marketing planning of tourist destinations. The synergic effects of collaborating in this area can enable stimulating the growth of developing new products. By achieving synergic collaboration effects it is possible to establish modern destination tourism development and be(come) competitive on the tourism market.*

**Keywords:** *collaboration, stakeholders, tourist destination marketing activities, hotel businesses, tourist boards*

## **1. INTRODUCTION**

In today's turbulent environment, tourist destinations are faced with numerous challenges regarding how to efficiently manage a destination and respond to future development challenges. Successful tourist destination management dictates that the integrated tourist destination product must be created and adapted both at the individual service provider and the tourist destination level. Although research by international authors indicates to numerous advantages of stakeholder collaboration in destination marketing, domestic literature claims that this issue has not been sufficiently researched. Moreover, research into stakeholder collaboration, importance and roles in the process of tourist destination marketing management intensified during the 1990's. Some of the key works were by: Palmer and Bejou (1995), Sheehan and Ritchie (2005), Sheehan, Ritchie and Hudson (2007), Bhat and Gaur (2012), Garrod and Fyall (2016), whose research is linked to the need for collaboration between stakeholders in order to increase the efficiency of tourist destination marketing activities. All the research by the above mentioned authors investigates tourist destination stakeholders who contribute to creating the tourist destination tourism product. Upon examining the domestic literature, it can be concluded that this topic did not evoke a significant scientific interest, therefore it can be said that there are sufficient theoretical and practical grounds for its research. The purpose of this paper is to investigate stakeholder collaboration when planning and implementing the marketing activities of tourist destinations. In accordance with this, the fundamental research objectives are as follows: (1) to improve the theoretical achievements in the area of researching the relationships and the collaboration of stakeholders in tourist destinations; (2) to research the attitudes of hotel businesses and tourist boards on the collaboration intensity with various stakeholders when planning and implementing tourist



destination marketing activities; (3) to determine differences in attitudes between hotel businesses and tourist boards regarding the collaboration intensity with stakeholders when planning and implementing tourist destination marketing activities; (4) to research the attitudes of hotel businesses and tourist boards on collaboration efficiency when planning and implementing tourist destination marketing activities; (5) to determine differences in attitudes of hotel businesses and tourist boards regarding collaboration efficiency when planning and implementing tourist destination marketing activities. This paper is divided into four parts. After the introduction, the second part presents an overview of current research of the concept of stakeholder relationship and collaboration in the area of tourist destination marketing. The third and central part of the paper describes the methodology and results of the empirical research. The final part presents a synthesis of the findings resulting from the conducted research, recommendations for marketing managers of hotel businesses and tourist boards, as well as the limitations of this research and recommendations for future research.

## **2. LITERATURE REVIEW**

The uniqueness of tourist destination products, as well as the complexity of relationships and interdependencies of the various service providers, stipulates a development of collaboration among them. Furthermore, the degree and intensity of collaboration determines the quality of the integral tourism product, and by implementing said collaboration each individual service provider achieves a competitive advantage, as well as the destination as a whole. In order to determine the stakeholders of a tourist destination, the term "stakeholder" itself must be analysed. From a destination viewpoint, the meaning of this term is defined as follows: "stakeholders are those with direct or indirect interest in the management of destination for tourism" (Morrison, 2013, p.23). The literature offers numerous typologies which identify the key stakeholders of tourist destinations. They can be grouped into four basic groups: public sector, private sector, local residents and tourists (Murphy and Murphy, 2004). Destination management organizations (DMOs) play a central role in marketing their geographic areas to meeting and convention planners, travel trade, individuals and other groups (Beldona, Morrison and Anderson, 2003). When fulfilling their marketing functions, DMOs contribute to the whole destination. To be able to develop coordinated marketing activities, DMOs need to adopt a strategy where a key component is the mobilisation of resources controlled by others, i.e. by the stakeholders involved (Elbe, Hallén and Axelsson, 2009). Therefore, Buhalis (2000) suggests a collaboration between stakeholders, especially between the public and private sector, in order to develop and integrated marketing process. Moreover, stakeholders need to be brought together in order to make it possible to mobilise resources for co-ordinated destination marketing (Elbe, Hallén and Axelsson, 2009). When considering the term "collaboration", it can be defined "as the process of shared decision-making among key stakeholders of a problem domain about the future of that domain" (Gray, 1985; referenced by Wang and Fesenmaier, 2007, p. 865). When collaborating, the (co)stakeholders are connected by their joint undertaking and support each other in order to achieve individual and mutual gain. Within the tourism domain, this might involve joint decision-making among all those parties having an interest or stake in tourism destination marketing (Wang and Fesenmaier, 2007). However, to what extent a certain stakeholder will be included in marketing management primarily depends on their interests. Therefore, the collaboration between stakeholders will not be of equal intensity. Based on previous empirical research on existing collaboration between destination management organizations and other stakeholders in tourist destinations, it has been established that the strongest connection exists with hotels/hotel associations, followed by the local and regional government, and attractions/attraction associations (Sheehan and Ritchie, 2005). One of the earliest research related to collaboration in the area of tourist destination marketing is that by Palmer and Bejou (1995) who examined the need for stakeholders to collaborate in order

to achieve greater efficiency of tourist destination marketing activities. The authors particularly emphasize the importance of cooperation between the private and public sector. Furthermore, the authors Augustyn and Knowles (2000) identify the basic elements for a successful partnership between the public and private sector in the tourist destination. One of the relevant studies in the area of public-private partnerships and research of their synergic effects is the WTO study Public-Private Sector Cooperation (WTO, 2000), in which all stakeholders in a number of countries are researched extensively on a national, regional and local level. The research is aimed at identifying the respondents' attitudes on the perception and importance of cooperation in the area of public and private collaboration in tourism. Potential areas of collaboration to improve destination marketing are also identified. In their research, authors Getz, Anderson and Sheehan (1998) research the role of the Convention and Visitors Bureaux in Canada's destination planning. It is concluded that the role of the CVB in in shaping the destination product is fairly low, while the level of involvement in destination planning usually consists of destination promotion. The research by Buhalis (2000) is also considered relevant, and he explains the concept of the tourist destination and states that tourist destination marketing should be the strategic goal of all stakeholders. Furthermore, Sheehan and Ritchie (2005) conduct a theoretical analysis of an empirical study into the stakeholders of destination management organizations, the conclusion being that the assessment of stakeholder potential as a threat and/or potential collaborator of destination management organizations helps identify the appropriate strategies and relationships towards each individual stakeholder. Furthermore, Sheehan, Ritchie and Hudson (2007) conducted research into destination management organizations, local administration and hotel associations, by means of the success of destination promotion. Their research proves that their mutual cooperation leads to successful destination promotion. Moreover, Wang and Xiang (2007) develop a model of cooperative destination marketing and conclude that partnership and networking is essential in order to improve organization competences at the tourist destination level. Wang (2008) researches mutual arrangements between tourist organizations involved in the management and promotion of a destination. It is concluded that such a level of collaboration is neither linear nor static, and several key phases in the collaboration process are identified. D'Angella and Go (2009) focus on applying marketing experience in tourism, especially with regard to the mutual relationship of destination management organizations and tourism business subjects. Elbe, Hallén and Axelsson (2009) pinpoint that in the process of collaborative destination marketing there is a need to coordinate and integrate marketing activities such as market research, planning, product offers, distribution and promotion. In their empirical research, Bornhorst, Ritchie and Sheehann (2010) develop a model which confirms the existence of a connection between the key tourist destination stakeholders and destination management organizations, with regard to social relationships, marketing and economic success indicators. Also, Boranić Živoder, Tomljenović and Čorak (2011), deal with the importance and role of stakeholders in tourist destinations. They found that stakeholder collaboration in Croatian coastal destinations is still insufficiently developed. However, tourist destination marketing was assessed as being better than other areas of collaboration.

### **3. EMPIRICAL RESEARCH**

This part of the paper describes and explains in detail the methods used in the research, as well as the questionnaire used to generate data, sampling information and the research results.

#### **3.1. Research methodology**

This research uses the survey method. The research instrument was a structured questionnaire which consisted of three groups of questions. The first group referred to the respondents' assessment of the intensity of collaboration with individual groups of stakeholders when

planning and implementing tourist destination marketing activities. The respondents were given ten groups of stakeholders, and were asked to assess the intensity of their own collaboration with the given stakeholder groups in the tourist destination by assigning a value from 1 (no collaboration) to 5 (excellent collaboration). The second group of questions examines the respondents' attitudes on the efficiency of collaboration according to various areas of planning and implementing tourist destination marketing activities. The respondents assessed the efficiency of collaboration based on 35 statements by assigning a value from 1 (no collaboration) to 5 (excellent collaboration). The scale by Boranić Živoder (2010, p. 267) was used to assess the efficiency of the collaboration (for four statements), and the WTO (2000, pp. 275-281) scale was used for twenty-four statements. For statements 1, 2, 22, 23, 29, 30 and 35 the author developed her own scale. The third part of the questionnaire consists of questions regarding the respondents' biodata. Two primary studies were conducted at the beginning of 2015. The research subjects were hotel businesses and tourist boards in Primorje-Gorski Kotar and Istria County, which represent the most developed tourist regions in Croatia (Sveučilište u Rijeci, Fakultet za menadžment u turizmu i ugostiteljstvu, 2012). The sample size corresponds with the total number of hotel businesses and tourist boards in Primorje-Gorski Kotar and Istria County, i.e. all the relevant units were included in the sample. The first research was conducted on persons in charge of planning and implementing marketing activities in hotel businesses in the counties Primorje-Gorski Kotar and Istria. The research included all hotel businesses which operate in both counties, in accordance with the Croatian Ministry of Tourism list of tourist facilities (from February 17th, 2015). It was found that, according to the aforementioned list, a total of 128 hotel businesses operate in these two counties (www.mint.hr; retrieved: 26.02.2015.). A total of 64 questionnaires was collected. Of the total number of completed questionnaires, 2 were not included in the sample due to being incomplete. It can therefore be said that the total number of completed questionnaires is 62, which is a completion rate of 48%, and thus the sample of hotel businesses included in the research is very satisfactory. The second research was conducted by examining the directors of the Primorje-Gorski Kotar and Istria County tourist boards. The research included all tourist boards active in the researched counties, in accordance with the list provided by the Croatian National Tourist Board. A total of 69 tourist boards operate in the two counties which were included in the research. A total of 53 questionnaires was collected, which represents a completion rate of 77%, and thus the sample of tourist boards included in the research is very satisfactory. Out of the 62 hotel businesses included in the sample, and with regard to the company's status, 66.1% are limited liability companies and 33.9% are public limited liability companies. Marketing activities are most frequently conducted by marketing departments (38.7%), while in 37.1% cases there is no special organizational unit. The persons completing the questionnaire were most commonly Head of Sales (35.5%), highly educated (69.4%) and female (56.5%). With regard to the type of tourist board, the sample of 53 tourist boards includes 52.8% of municipal tourist boards, and 32.7% of city tourist boards. Two tourist boards are at the county-level, which constitutes 3.8% of the sample, and two tourist boards refer to a designated area. One tourist board included in the sample is at the settlement-level. The persons completing the questionnaire were mostly highly educated (58.5%) and female (64.2%).

### **3.2. Analysis and interpretation of the research results**

Considering that the collaboration was assessed by both groups of stakeholders (hotel businesses and tourist boards), this research aims to determine whether there is a statistically significant difference between the average assessment of the included stakeholder groups. In order to yield the best results, the Independent Samples t-Test was used. The analysis was based on the entire stakeholder sample, i.e. it includes stakeholders from both counties.

Table 1 provides a comparison of the average assessment regarding the stakeholder collaboration intensity when planning and implementing tourist destination marketing activities.

*Table 1: Comparison of average assessments for stakeholder collaboration intensity when planning and implementing tourist destination marketing activities (research results)*

Variable	HB (Mean)	SD	TB (Mean)	SD	T-test	Sig.
Local authorities (municipalities/cities)	2.77	1.122	3.85	1.008	-5.364	0.000*
Regional governments (counties)	2.47	1.141	3.30	0.932	-4.246	0.000*
Hotel businesses/tourist boards	3.04	1.183	3.30	1.295	-1.200	0.233
Travel agencies	3.55	1.066	3.25	1.072	1.515	0.132
Transport undertakings	3.16	1.059	2.87	1.110	1.448	0.150
Other businesses (motels, campsites, restaurants, etc.)	3.10	0.970	3.55	0.911	-2.552	0.012**
Various business associations (chambers of commerce, private accommodation providers' associations, etc.)	2.82	1.109	3.43	0.866	-3.253	0.002*
Other non-business associations (active in culture, art, ecology, heritage protection)	2.92	1.106	3.58	0.887	-3.519	0.001*
Health, religion, recreation, culture and other institutions in the destination	2.95	1.151	3.15	0.949	-1.003	0.318
Individual businesses which are of greater significance in the structure of the tourist offer (private island shipping companies, etc.)	2.97	1.130	3.13	1.161	-0.768	0.444
Overall average score	2.99		3.34			

*Note: HB – hotel businesses; TB – tourist boards; SD – Standard deviation; Sig. – significance. \* Significant difference is  $p = 0.01$ . \*\* Significant difference is  $p = 0.05$ .*

Table 1 shows that hotel businesses assess that their collaboration with travel agencies is the best, and tourist boards emphasize the collaboration with local authorities. On the other hand, hotel businesses state that their worst collaboration is with regional governments, while tourist boards state that their worst collaboration is with transport undertakings. The overall average score for hotel businesses is 2.99, and for tourist boards 3.34, which indicates a moderate collaboration intensity. Hotel businesses gave higher scores than tourist boards to two variables (travel agencies and transport undertakings). In all other cases the stakeholder collaboration intensity was assessed as higher by tourist boards. T-test results show that the observed differences are statistically significant ( $p < 0.05$ ) in the following cases: collaboration with local authorities, regional governments, other businesses, various business associations and other non-business associations. It can therefore be concluded that tourist boards state that their collaboration intensity with the aforementioned stakeholders is significantly better than that of hotel businesses. In other cases, both tourist boards and hotel businesses similarly assess the intensity of their collaboration with stakeholders, i.e. there is no statistically significant difference in how they assessed their collaboration. The following table provides a comparison of average assessments regarding the efficiency of collaboration in planning and implementing tourist destination marketing activities.

*Table 2: Comparison of average assessments for the efficiency of collaboration with hotel businesses/tourist boards regarding the planning and implementing of tourist destination marketing activities (research results)*

Variable	HB (Mean)	SD	TB (Mean)	SD	T-test	Sig.
Process of developing a county tourism strategic marketing plan	2.32	1.068	2.85	1.231	-2.456	0.016**
Control of the implementation of the county tourism strategic marketing plan	2.19	0.955	2.72	1.199	-2.604	0.010*
Conducting competition analysis	2.18	0.933	2.49	1.012	-1.726	0.087
Benchmarking analysis	2.21	0.926	2.53	1.120	-1.646	0.103
Collecting and distributing data regarding the destination's tourist traffic	3.18	1.033	3.53	1.353	-1.543	0.126
Target market research	2.40	0.966	2.81	1.128	-2.091	0.039**
Spotting market opportunities	2.47	1.004	2.98	1.232	-2.462	0.015**
Improving the competitive position of the destination	2.34	1.070	3.08	1.238	-3.423	0.001*
Identifying new sources of competitive advantage	2.34	1.039	2.85	1.199	-2.445	0.016**
Defining destination goals and strategies	2.42	1.033	3.13	1.241	-3.361	0.001*
Improving the quality of information used when making strategic decisions	2.32	1.021	2.79	1.133	-2.339	0.021**
Developing and improving destination sights	2.55	1.003	2.98	1.135	-2.171	0.032**
Introducing quality standards in the destination	2.48	0.901	2.92	1.124	-2.333	0.021**
Organizing special events	3.02	0.967	3.47	1.250	-2.202	0.030**
Organizing events to contribute to enriching the tourist offer	3.10	0.987	3.55	1.309	-2.055	0.043**
Selective development of facilities and events	2.65	0.925	3.13	1.177	-2.482	0.015**
Development of recreation and sports facilities	2.60	1.123	3.11	1.204	-2.378	0.019**
Development of entertainment facilities	2.66	1.039	2.98	1.201	-1.531	0.128
Development of special interest tourism	2.48	0.971	2.79	1.044	-1.641	0.104
Improving the quality of tourist information	2.90	0.970	3.25	1.142	-1.737	0.085
Development and improvement of accommodation facilities in the destination	2.60	0.983	3.30	1.218	-3.435	0.001*
Development and improvement of the quality of hotel services	2.63	1.028	3.02	1.278	-1.812	0.073
Development and improvement of the equipment of hotel facilities	2.53	1.051	2.87	1.272	-1.550	0.124
Improving the destination image	2.81	1.084	3.30	1.265	-2.262	0.026**
Improving the business entity image	2.74	1.039	3.08	1.269	-1.550	0.124
Advertising and public relations	2.82	0.967	3.19	1.257	-1.763	0.081
Development of promotional material for the destination	3.05	1.078	3.21	1.291	-0.720	0.473
E-marketing of the destination	2.89	1.057	3.08	1.313	-0.852	0.396
Promoting the destination tourist offer at fairs both in Croatia and abroad	3.05	1.122	2.89	1.266	0.726	0.470
Development and improvement of sales by using destination reservation systems	2.16	1.027	2.30	1.067	-0.719	0.474
Organising education and training for tourist workers	2.24	1.019	2.77	1.154	-2.623	0.010*
Organising seminars and workshops	2.39	1.014	2.85	1.150	-2.289	0.024**
Joint study trips	2.11	1.057	2.36	1.226	-1.140	0.257
Improving the quality of destination management	2.11	1.010	2.87	1.177	-3.702	0.000*
Raising awareness on the importance of economic, social and other effects of tourism	2.29	1.046	3.06	1.099	-3.825	0.000*
Total average score	2.55		2.97			

*Note: HB – hotel business; TB – tourist boards; SD – Standard deviation; Sig. – significance. \* Significant difference is  $p = 0.01$ . \*\* Significant difference is  $p = 0.05$ .*

As is shown by the previous table, hotel businesses assess that they collaborate the best with tourist boards regarding collecting and distributing data regarding tourist traffic in the destination, while tourist boards assess that they collaborate the best with hotel businesses

regarding the organization of events which contribute to enriching the tourism offer. On the other hand, hotel businesses rated the collaboration in the area of joint study trips and improving the quality management of the destination as being the worst. Tourist boards assess the collaboration in the area of developing and improving sales via destination booking systems as being the worst. The total average score for hotel businesses is 2.55 and for tourist boards 2.97, which indicates a moderate mutual cooperation. The negative t-test results indicate that the analysed tourist board sample assesses the collaboration efficiency with hotel businesses for the area included in the research better than hotel businesses assess the collaboration efficiency with tourist boards. The only exception is the variable "Promoting the destination tourist offer at fairs both in Croatia and abroad", for which hotel businesses gave a higher score than tourist boards. The t-test results indicate that the observed differences are statistically significant for the majority of the analysed variables ( $p < 0.05$ ). Therefore, in these areas, tourist boards assess the collaboration with hotel businesses as being significantly better than hotel businesses assess their collaboration with tourist boards. The remaining statements display accidental differences, i.e. they are not statistically significant ( $p > 0.05$ ). It can thus be concluded that hotel businesses and tourist boards similarly assess the efficiency of their collaboration in the following areas: "Conducting competition analysis", "Benchmarking analysis", "Collecting and distributing data regarding the destination's tourist traffic", "Development of entertainment facilities", "Development of special interest tourism", "Improving the quality of tourist information", "Development and improvement of the quality of hotel services", "Development and improvement of the equipment of hotel facilities", "Improving the business entity image", "Advertising and public relations", "Development of promotional material for the destination", "E-marketing of the destination", "Promoting the destination tourist offer at fairs both in Croatia and abroad", "Development and improvement of sales by using destination reservation systems", and "Joint study trips".

#### **4. DISCUSSION AND CONSLUSION**

Based on the results gained by the research, certain conclusions can be brought and recommendations made to improve the collaboration between stakeholders in tourist destinations. Hotel businesses have the best collaboration with travel agencies, while tourist boards collaborate the best with local authorities. The latter is in accordance with the findings by Sheehan and Ritchie (2005) who proved that the best DMO collaboration is between hotels and local governments. The research results also show that the worst collaboration of hotel businesses is with regional governments, while for tourist boards the worst collaboration is with transport undertakings. Moreover, tourist boards assess the intensity of their cooperation with individual stakeholders as much better when compared to hotel businesses. Research results have shown that the mutual collaboration efficiency in the area of planning and implementing marketing activities of a tourist destination is moderate. Although the research by Boranić Živoder, Tomljenović and Čorak (2011) found a low level of collaboration between stakeholders, the collaboration regarding the marketing of a tourist destination received higher average scores than other areas of collaboration, which is in line with the research conducted in this paper. When comparing the research results for hotel business entities and tourist boards in terms of the collaboration efficiency when planning and implementing marketing activities for the tourist destination, it can be concluded that tourist boards awarded higher scores for the collaboration in most of the researched areas compared to hotel businesses. Hotel businesses have the best collaboration with tourist boards in the area of collecting and distributing data regarding tourist traffic in the destination, while tourist boards believe that their best collaboration with hotel businesses is in organizing events that contribute to enriching the tourist offer. On the other hand, hotel businesses gave the worst score to collaborating on joint study trips and improving the destination management quality.

Tourist boards assessed that the worst collaboration was regarding the development and improvement of sales using destination reservation systems. Management of hotel businesses and tourist boards should primarily collaborate regarding strategic marketing planning of tourist destinations. The synergic effects of collaborating in this area can enable stimulating the growth of developing new products. In this sense, the development of new products should be directed to ensuring a wealth of events and experiences in the destination, especially outside the summer season, with the purpose of avoiding seasonal business, i.e. in order to create conditions for increasing the capacity utilization of hotel businesses. Establishing a connection and collaboration between all stakeholders in the tourist destination, especially with regard to hotel businesses, local/regional governments and tourist boards, since they are the most powerful stakeholders in the destination (Sheehan, Ritchie and Hudson, 2007), would lead to having all marketing activities at the destination level coordinated and harmonized. By achieving synergic collaboration effects it is possible to respond to the challenges imposed by the modern tourism environment, establish modern destination tourism development and be(come) competitive on the tourism market. There are several limitations which should be considered when discussing the results of this research. First, the research was conducted on Croatian businesses and tourist boards and is, therefore, spatially limited. Furthermore, the research only dealt with two coastal counties of the Republic of Croatia, which means that the research has a narrow and regional character. Also, this research focused on the key stakeholders in tourist destinations: hotel businesses and tourist boards. Future research should also include other stakeholders in the private and public sector. Overcoming the aforementioned limitations could provide guidelines for future research.

#### **LITERATURE:**

1. Augustyn, M. M. and Knowles, T. (2000). Performanse of tourism partnerships: a focus on York. *Tourism Management*, Vol. 21, No. 4, pp. 341-351.
2. Beldona, S., Morrison, A. M. and Anderson, D. J. (2003). Information exchange between Convention and Visitor Bureaus and hotels in destination marketing: a proposed model. *Journal of Convention & Exhibition Management*, Vol. 5, No. 1, pp. 41-56.
3. Bhat, S. and Gaur, S. S. (2012). Managing diverse stakeholders in the context of destination marketing. *Worldwide Hospitality and Tourism Themes*, Vol. 4, No. 2, pp. 185-202.
4. Boranić Živoder, S. (2010). *Upravljanje turističkom destinacijom u funkciji održivog razvoja turizma*. Doktorska disertacija, Sveučilište u Zagrebu, Ekonomski fakultet Zagreb, Zagreb.
5. Boranić Živoder, S., Tomljenović, R. and Čorak, S. (2011). Suradnja interesnih skupina u turističkim destinacijama. *Izazovi upravljanja turizmom*, Institut za turizam, Zagreb, 2011., pp. 15-31.
6. Bornhorst, T., Ritchie, J.R.B. and Sheehan, L. (2010). Determinants of tourism success for DMOs & Destinations: An empirical examination of stakeholders' perspectives. *Tourism Management*, Vol. 31, No. 5, pp. 572-589.
7. Buhalis, D. (2000). Marketing the competitive destination of the future. *Tourism management*. Vol. 21, No. 1, pp. 97-116.
8. D'Angella, F. and Go, F.M. (2009). Tale of two cities' collaborative tourism marketing: towards a theory of destination stakeholder assessment. *Tourism Management*, Vol. 30, No. 3, pp. 429-440.
9. Elbe, J., Hallén, L. and Axelsson, B. (2009). The destination-management organisation and the integrative destination-marketing process. *International journal of tourism research*, Vol. 11, No. 3, pp. 283-296.

10. Garrod, B. and Fyall, A. (2016). Collaborative destination marketing at the local level: benefits bundling and the changing role of the local tourism association. *Current Issues in Tourism*, Vol. 20, No. 7, pp. 668-690.
11. Getz, D., Anderson, D. and Sheehan, L. (1998). Roles, issues and strategies for convention and visitors' bureaux in destination planning and product development: a survey of Canadian bureaux. *Tourism Management*, Vol. 19, No.4, pp. 331-340.
12. *Izmjene i dopune Glavnog plana razvoja turizma Primorsko-goranske županije (2012)*, Sveučilište u Rijeci, Fakultet za menadžment u turizmu i ugostiteljstvu, Opatija.
13. Morrison, A. M. (2013). *Marketing and managing tourism destinations*. Routledge, New York.
14. Murphy, P. E. and Murphy, A. E. (2004). *Strategic Management for Tourism Communities: Bridging the Gaps*. Channel View Publications, Clevedon.
15. Palmer, A. and Bejou, D. (1995). Tourism destination marketing alliances, *Annals of Tourism Research*. Vol. 22, No. 3, pp. 616-629.
16. www.mint.hr (pristup: 26.02.2015.)
17. *Public – Private Sector Cooperation: Enhancing Tourism Competitiveness (2000)*. WTO Business Council, Madrid.
18. Sheehan, L. R. and Ritichie, J. R. B. (2005). Destination Stakeholders Exploring Identity and Saliency. *Annals of Tourism Research*, Vol. 32, No. 3, pp. 711-734.
19. Sheehan, L. R., Ritichie, J. R. B and Hudson, S. (2007). The destination promotion triad: understanding the asymmetric stakeholder interdependencies between the city, the hotels and the DMO. *Journal of Travel Research*, Vol. 46, No. 1, pp. 64-74.
20. Wang, Y. (2008). Collaborative destination marketing: understanding the dynamic process, *Journal of Travel Research*. Vol. 47, No. 2, pp. 151-166.
21. Wang, Y. and Fesenmaier, D. R. (2007). Collaborative destination marketing: A case study of Elkhart county, Indiana. *Tourism Management*, Vol. 28, No. 3, p. 863-875.
22. Wang, Y. and Xiang, Z. (2007). Toward a theoretical framework of collaborative destination marketing. *Journal of Travel Research*, Vol. 46, No. 1, pp. 75-85.



## THE LEGAL ENVIRONMENT OF BUSINESS – REMEDIAL PROCEEDINGS IN CASE OF INSOLVENCY OF THE ENTERPRISE IN POLAND (SELECTED ISSUES)

**Monika Smusz - Kulesza**

*The University of Lodz, Poland,*

*The District Court for Lodz-Srodmiescie in Lodz, Poland*

*msmusz@go2.pl*

### **ABSTRACT**

*The aim of the study is to discuss the remedial proceedings as a way to avoid declaring bankruptcy and ensure further activity of the enterprise which is insolvent or threatened with insolvency in Polish legal system. The analysis reflects the comparison between the remedial proceedings and other restructuring procedures established under Polish regulations. The paper concentrates on the characteristics of the subsequent stages of the remedial procedure and the possibilities of using different legal measures to safeguard the interests of the insolvent enterprise at each stage of the procedure. In particular, the procedure to secure the property of a debtor, the restructuring plan and the restructuring measures are in focus. The article not only pays attention to legal regulation of the abovementioned procedure but also to practical consequences and possible threats to the wellbeing of the enterprise after issuing an application for the opening of remedial proceedings. Subject to analysis is also the right time to initiate the remedial proceedings and possible consequences of not initiating it in the right time. Last part of the text concentrates on the process of concluding the arrangement by the debtor with his creditors. Description of the procedures of establishing the inventory of receivable debts and convening the meeting of creditors in order to hold a vote on the arrangement is limited with the stress being put on the receivable debts which are covered by the arrangement.*

**Keywords:** *bankruptcy, insolvency, remedial procedure, restructuring procedure, restructuring plan*

### **1. INTRODUCTION**

Since 1 January 2016 the procedure in case of financial problems or insolvency of the enterprise in Poland has been regulated mainly by the texts of two acts - the Bankruptcy Law of 28 February 2003 (until 1 January 2016 known as the Bankruptcy and Reorganisation Law) and the Restructuring Law of 15 May 2015 (which is an entirely new legal act). These two acts regulate the situation of enterprises that are struggling with severe financial problems – both at an early stage (the threat of liquidity loss) and at its very advanced stage (bankruptcy). The aims of procedures regulated by the Bankruptcy Law and The Restructuring Law are different – in case of bankruptcy procedure the aim is to enable the claims of the creditors to be satisfied to the greatest extent and, where the practical conditions allow, the existing enterprise of a debtor to be preserved. In case of restructuring procedures the aim is to avoid declaration of bankruptcy of a debtor through enabling him to undergo restructuring by making an arrangement with creditors and, in the case of remedial proceedings, also through conducting remedial actions, while securing legitimate rights of creditors. The Restructuring Law distinguishes four different restructuring procedures that can be initiated in the Restructuring Court. These are the arrangement approval proceedings; the accelerated arrangement proceedings; the arrangement proceedings and the remedial proceedings. The essence of three arrangement proceedings is in fact the same. Their purpose is to conclude the arrangement between the debtor and the creditors under the supervision of the Restructuring Court without any measures which are to be taken before the arrangement. The premises differentiating various types of arrangement proceedings are only the procedure of voting and the total sum of disputed receivable debts.

Separate to the arrangement proceedings is the remedial proceedings both because of the premises of initiating and because of the scope of possible measures that can be taken in the course of the procedure. (Witosz, 2015, p. 11-12) The remedial proceedings shall enable the debtor to carry out remedial actions and conclude the arrangement after the inventory of receivable debts has been prepared and approved. The remedial actions shall include legal and factual acts which aim to improve the economic situation of the debtor and to restore the debtor's capacity to perform his obligations, while protecting him against debt enforcement proceedings. As the aforementioned regulations demonstrate, the remedial procedure is the restructuring procedure that gives the debtor the widest opportunities to restore the longterm viability of the company. This is also the longest and the most complex of all restructuring procedures.

## **2. PROCEEDINGS FOR THE OPENING OF THE REMEDIAL PROCEDURE**

### **2.1. Locus standi and formal requirements of the application**

Remedial procedure – as all restructuring procedures – consists of two main parts: proceedings for the opening of remedial proceedings and proceedings after the opening of remedial proceedings (the proper/pure remedial proceedings). Proceedings for the opening of remedial proceedings is initiated by an application. The person who is legitimate to initiate each restructuring procedure is the debtor himself and the persons representing the debtor being a legal person or an unincorporated entity in which a separate law vests legal capacity. An application for the opening of remedial proceedings in relation to a corporate entity entered in the National Court Register may also be made by the custodian appointed pursuant to Article 26 section 1 of the Act of 20 August 1997 on the National Court Register. As exception thereto, the remedial proceedings, in case of an insolvent legal person, can be initiated also by a personal creditor. It is only the legal person that may continue irrespective of the will of the debtor. Both natural persons pursuing commercial activity and partnerships depend on the will of a debtor/partners to such an extent that undergoing successful restructuring process without their acceptance is impossible. Legal person, by its nature, can be separated from its management board and because of that remedial proceedings, as constructed on the basis of taking the management off the debtor, can be carried out even without debtor's consent (Zimmerman, 2018, Legalis). Creditor with a mortgage or pledge can initiate the proceedings for opening of the remedial proceedings only when one is the personal creditor of the debtor at the same time. Creditor with a mortgage or pledge who is not the personal creditor of the debtor is not legitimate to apply for opening of the remedial proceedings. Application that is issued by such a creditor should be dismissed due to the lack of title to bring the action before the court. Formal requirements of the application for the opening of remedial proceedings are set out in article 284 of The Restructuring Law (further also as RestLaw). Application covers, inter alia, precise indentifying data of the participants – the applicant and the debtor (if the debtor is not the applicant), initial restructuring plan, the total sum of receivable debts and the list of creditors. The fee for the application is 1.000 PLN (around 230 Euro). The court may demand an advance payment from the debtor to cover the expenses of the procedure for the opening of remedial proceedings, otherwise the activity connected with the call for the advance payment shall be omitted, or in respect of a call for an advance payment for the remuneration of the temporary court supervisor or temporary administrator, otherwise the proceedings shall be discontinued (art. 285 RestLaw). Regulation of art. 285 RestLaw in practice can cause a lot of problems. According to this regulation it is the debtor who is called to make the advanced payment for the expenses of the proceedings no matter who is the applicant. In proceedings which are initiated by the creditor, against the will of a debtor, a debtor may cause obstruction in the proceedings and refuse to pay. This should literally cause discontinuation of the proceedings which seems against the possibility of initiating the remedial proceedings not only by a debtor but also by his personal creditor.

In such a case the solution should be applying regulations of the Civil Procedure Code (art. 103 (4) § 1 in connection with art. 209 RestLaw) and calling the applicant to an advance payment for covering the expenses of the procedure. The possibility of applying the regulations of the Civil Procedure Code in the matter which is partially regulated by The Restructuring Law is based on the functional interpretation assuming that reasonable legislator do not create rules of law which aim cannot be reached because of the conflict between the regulations of the act (differently A. Malmuk-Cieplak, 2016, Lex; similarly P. Filipiak, 2016, Lex).

## **2.2. Proceedings to secure property of a debtor**

In the procedure for the opening of remedial proceedings, the court may secure the property of a debtor. Basic ways of securing the property are enumerated in the Restructuring Law, additionally, under the regulation of article 287 RestLaw, the court may use the ways of securing enumerated in the Civil Procedure Code. The aim of securing procedure in case of the procedure for the opening of remedial proceedings is to secure the assets of a debtor to the greatest extent in such a way to enable the debtor to continue or even restore the activity of the enterprise despite high level of liabilities. Through restronig viability the debtor increases his ability to pay the debts which serves the interest of creditors. Under the regulation of art. 737 of the Civil Procedure Code in conetion with art. 287 of the Restructuring Law, the application for securing the property of a debtor should be dealt with without delay, not later than within a week of the day when it was filed. The Restructuring Law enumerates four basic ways of securing the properties of a debtor – all of them serve different needs of both the debtor and the creditors as a group. Three of them are autonomous and the fourth one may be introduced only together with the other ones. The ways of securing the property of a debtor which are autonomous are: by the appointment of a temporary court supervisor, by the appointment of a temporary administrator or by the suspension of the enforcement proceedings led against the debtor. The decision of appointing a temporary court supervisor or a temporary administrator shall be announced in the official national Register. The fourth way of securing the property of a debtor – by revocation of the seisure of bank accounts – is not autonomous. The Restructuring Court may abolish the seisure of bank accounts only in case of suspension of the enforcement proceedings led against the debotr and in such a case the court is obliged to appoint a temporary court supervisor if the supervisor has not been appioined before. In the procedure for the opening of remedial proceedings, the proceedings to secure property is facultative, which means the court is not obliged to appoint the temporary court supervisor or temporary administrator no matter who applies for the opening of the proceedings – the debotr or the personal creditor. The optionality of the procedure to secure the property does not exclude the possibility of initiating the procedure by the Restructuring Court itself. The court of its own motion, may appoint the temporary court supervisor or temporary administrator. In the application for the opening of remedial proceedings the applicant may also request to secure the property of a debtor in one of these two ways – which obliges the court to deal with the request. Securing properties by the suspension of the enforcement proceedings led against the debtor and by revocation of the seisure of bank accounts is possible only on application by the debtor or a temporary court supervisor. The Restructuring Court may not secure the properties of the debtor in this way by its own motion. As it comes to the premises of appointing the temporary supervisor or the temporary admnistrator none of the provisions regulating procedure to secure the property of a debtor indicates when the Restructuring Court should appoint them. It seems appropriate to assume that the court shall secure the property by appointing a temporary supervisor when there is a need to control the activity of a debtor but it is enough to limit the debotr in the possibility to perform acts exceeding the scope of ordinary administration. After appointing the temporary court supervisor the debtor may perform acts of ordinary administration by his own and in case of acts exceeding the scope of ordinary

administration the debtor needs the consent of the temporary court supervisor. The second way of securing the property of a debtor – by appointing temporary administrator – should be used when the first one may seem insufficient and simultaneously there is evidence or well-founded fear that the debtor may exercise control over the company incorrectly or one does not exercise it at all. (Zimmerman, 2016, p. 1590) The temporary administrator should also be appointed when there is evidence that the debtor performs actions detrimental to creditors and it is the personal creditor who applies for opening of the remedial proceedings. Securing the property of a debtor by the suspension of the enforcement proceedings led against the debtor aims at securing the property of a debtor from the activity of some of the creditors and gives the possibility to retain the enterprise as a whole capable of further activity, which most often is the most important condition for implementing the arrangement. The suspension of the enforcement proceedings relates to all liabilities covered by the arrangement. It means that the suspension relates both to private and public institutional liabilities, but it does not relate to liabilities excluded from the arrangement (e.g. the maintenance, invalidity or death pensions or social security contributions) and to those, which are covered by the arrangement only with the consent of the creditor (employment liabilities and liabilities covered by valuable security). The fourth way of securing the property of a debtor – by revocation of the seizure of bank accounts may be applied only together with suspending the enforcement proceedings and appointing the temporary court supervisor. This way of securing the property may be especially important for the debtor as usually it is not possible to operate the business without free access to the bank accounts. Interests of creditors are secured by obligatory appointment of the temporary court supervisor in such a case. Besides basic ways of securing the property of a debtor enumerated in the Restructuring Law – which should be introduced in the first place – the court may also apply all ways of securing enumerated in the Civil Procedure Code. For instance the court may secure the property through the revocation of the seizure of movables such as storage, machinery or vehicles. If the restructuring procedure is initiated by a personal creditor and there is a risk the debtor will dispose of the assets the court may both appoint the temporary administrator and secure the property by establishing the prohibition on disposal and encumbrance of the individual assets (differently A. Hrycaj, 2016, Legalis).

### **2.3. The premises of opening of the remedial proceedings**

Restructuring proceedings may be conducted against a debtor who is insolvent or threatened with insolvency (art. 6 RestLaw). As the Restructuring Law is designed for both insolvent debtors and debtors threatened with insolvency, it is absolutely unnecessary for the Restructuring Court to determine if the debtor is insolvent or threatened with insolvency. The only exception is considering these premises in case of an application to open remedial proceedings issued by a creditor, as according to article 283 par. 2 RestLaw application to open remedial proceedings can be issued by a creditor only in respect of an insolvent legal person. That means if the application is issued by a creditor in respect of a debtor who is not insolvent but only threatened with insolvency the court must dismiss the application. The state of insolvency of a debtor is defined in art. 11 of the Bankruptcy Law of 28 February 2003, to which the Restructuring Law refers. Under the definition included in this act a debtor is considered insolvent, if one is no longer able to pay his debts as they fall due. The Bankruptcy Law makes a legal presumption of insolvency in case of the delay in the payment of debts exceeding three months. A debtor who is a legal person or an organisational unit without legal personality that is granted legal capacity, is also considered insolvent when their debts exceed the value of their assets and this state of affairs persists for a period longer than twenty four months. The state of threat of insolvency happens when the economic situation of a debtor suggests that he may shortly become insolvent. Another premises of opening the remedial proceedings are defined in art. 8 of the Restructuring Law and are negative which means they

must not occur for the remedial proceedings to be opened. These premises are: detrimental effect of remedial proceedings to the creditors and lack of ability of the debtor to pay current costs of proceedings and to perform any obligations arisen after their opening. The term "effect of proceedings that would be detrimental to creditors" is a typical general clause, which is filled with content by the court while deciding on opening of the remedial proceedings or dismissing the application. Detrimental effect of the proceedings may be determined for example when the activity of the debtor and the way in which the debtor is managing the enterprise or the way in which the debtor is negotiating with creditors indicate that the true aim of the debtor is to avoid the enforcement proceedings or to go through the arrangement with the use of the creditors concluding apparent contracts with the debtor. (Gurgul, 2018, Legalis)

#### **2.4. The ruling on the opening of remedial proceedings**

An application for the opening of the remedial proceedings shall be examined by the court – as a rule - at a closed session within two weeks of the day when it was filed, unless it is necessary to schedule a hearing. In such a case the application shall be examined within six weeks. To follow the rule of issuing the decision within two weeks, the court should base the adjudication exclusively on documents provided by the applicant as the time set out by the legislator is too short to proceed with calling the debtor to make an advanced payment for the expenses of the securing procedure and wait for the report of the temporary court supervisor. Implementing the procedure to secure the property of a debtor automatically causes failure to complying with the non-binding time limit set in the Restructuring Law. Because of this adjudicating on the basis of documents enclosed to the application for opening of the remedial procedure should be the rule and introducing the securing procedure should be an exception used only in those cases when the documents supplied by the applicant do not provide information inevitable to make the decision. While granting the application for the opening of remedial proceedings, the court shall issue a decision to open the remedial proceedings. The decision shall be announced in the Register. In the decision the court designates a judge-commissioner, deprives the debtor of self-administration and appoints an administrator. If personal participation of the debtor or the representatives of the debtor is required for remedial proceedings to be carried out effectively and at the same time these persons give warranty of proper exercise of the administration, the court may permit the debtor to perform administration over the whole or a part of the undertaking to a degree not exceeding ordinary administration. Permitting the debtor to manage ordinary administration does not limit in any way the administrator in conducting management of the bankrupt entity's assets. In such a case both the administrator and the debtor may perform ordinary administration and only the administrator may perform activities exceeding ordinary administration. The official stance of the doctrine of the Restructuring Law is that if the debtor appointed ordinary administration makes an agreement, administrator cannot makes it invalid (Zimmermann, 2018, Legalis). A decision on refusal to open remedial proceedings may be complained against only by the debtor. A pronouncement on the opening of proceedings by a second-instance court is inadmissible. A creditor within a week from the date of the announcement of the decision to open remedial proceedings in the Register may lodge an appeal against this decision exclusively in the part concerning the jurisdiction of Polish courts. The term for a creditor who, on the day when the proceedings were opened, had his seat or ordinary place of stay abroad is thirty days. The decision to open remedial proceedings is effective and enforceable as of the date of its issuing. The effectiveness and enforceability of the decision to open the remedial proceedings is not limited. In particular the possibility of questioning by a creditor the basis for the jurisdiction of Polish court does not have any influence on the course of the procedure. Subsequent stages of the proceedings should be taken in accordance with the the Restructuring Law. The list of creditors should be established and approved by the court, restructuring plan should be submitted, approved and implemented, even the meeting of the

creditors should be called, voting ordered and the arrangement agreed and approved without awaiting for the result of the appeal concerning the jurisdiction. The result of the appeal decides only if the proceedings is main/primary or secondary one.

### **3. PROCEEDINGS AFTER THE OPENING OF THE REMEDIAL PROCEDURE (THE PROPER / PURE REMEDIAL PROCEEDINGS)**

#### **3.1. Preparation and performance of the restructuring plan**

In the proceedings after the opening of the remedial procedure there are two main stages deciding if the restructuring process will be successful: preparation and performance of the restructuring plan and concluding the arrangement between the debtor and the creditors. Restructuring plan is one of the main documents prepared during the restructuring process. It is the evidence base for the whole restructuring proceedings. The purpose of the restructuring plan is to provide the court, the judge-commissioner, the court administrator and the creditors with the knowledge about the enterprise enabling them to analyse the propositions of restructuring measures in the context of their enforceability, the level of risk and their compliance with the condition of the enterprise. Preparation of the restructuring plan is obligatory. Its content is defined in art. 10 RestLaw. Preparing the plan in a remedial procedure is the duty of an administrator. Regulations establish also the role of a debtor in preparing the plan. The debtor should act in consultation with the administrator. If the administrator fails to reach agreement on the contents of the plan with the debtor, he shall submit the plan adding objections of the debtor and the reasons why he failed to take these objections into account. Third parties e.g. experts may prepare the restructuring plan only in exceptional cases, on behalf of the administrator and with prior acceptance of the judge-commissioner. The restructuring plan shall be provided to the judge-commissioner within thirty days of the date of opening of the remedial proceedings by the administrator who is the person responsible for its content. In duly justified cases the time limit for submitting the restructuring plan may be extended by the judge-commissioner up to three months. The deadline for preparing the restructuring plan is non-binding, violating the term may render the administrator liable to disciplinary action. The restructuring plan shall be filed in electronic form and entered into the Register. This way it comes available to all interested – especially to the creditors who can assess the probability of its performance and basing on this assessment they can make decision concerning the acceptance of the restructuring proposals. The plan will replace separate justification of the restructuring proposals and the creditors will be able to verify the advances in its performance during implementation of the arrangement. (Justification, 2015, p. 17). The Restructuring Law indicates obligatory, minimum components of the restructuring plan. The level of details depends on many factors such as e.g. the size of the enterprise or the scope of restructuring. The content of the plan may not consist only with general wording and should be clear enough to consider if the plan provides real possibility of restructuring. The plan should include as much information as possible for the creditors to establish their opinion considering the reality of performing the underlying assumptions. In practice it is not rare that some parts of the plan are more complex than the others (Adamus, 2015, Legalis). Among others the restructuring plan should contain a full description and review of planned restructuring measures and related costs; a schedule of implementation of restructuring measures and the final time limit for the restructuring plan implementation (art. 10 par. 1 p. 4 – 5 RestLaw). Where in remedial proceedings it is anticipated that there will be reductions in employment using the empowerment of the administrator to terminate the employment of specially secured employees with whom it is impossible to terminate employment in ordinary conditions, the restructuring plan shall additionally indicate the principles of dismissing employees, in particular the number of employees covered by the intended dismissal, the period in which they will be dismissed and the proposed criteria of dismissing employees.

Restructuring plan should be approved by the judge-commissioner after receiving an opinion of the committee of the creditors if it has been established in the proceedings. The judge-commissioner may issue an injunction against implementation of certain actions provided for in the restructuring plan and order the implementation of other actions, guided by the objectives of the remedial proceedings and the protection of the legitimate rights of the creditors and third parties who are not participants in the proceedings. Administrator is bound by the instructions given by the judge-commissioner in the decision that is non-actionable. In case of issuing by the judge-commissioner the decision changing the restructuring plan the liability for the damage incurred by those changes shall be borne by the Treasury of State. Due to this the judge-commissioner shall issue such decisions with considerable caution – especially taking into consideration the knowledge and experience in the area of economy, market rules and business that is needed to prepare the restructuring plan. After the approval restructuring plan shall be performed by an administrator. Before approving the restructuring plan, the administrator may only take action to restore the capacity of the debtor to perform his obligations if failure to take them immediately would seriously hamper the possibility of achieving the objectives of the remedial proceedings. In the course of performance the plan may be amended, according to changes in the circumstances of the case.

### **3.2. The arrangement**

Forthwith after the implementation of the restructuring plan in full or in the part anticipated to be performed during the remedial proceedings, but no later than before the lapse of twelve months from the day when remedial proceedings were opened the judge-commissioner shall convene a meeting of the creditors in order to vote on the arrangement. If up to this time the inventory of receivable debts is not approved or the procedure of obtaining consent for granting public aid is not completed, the judge-commissioner shall convene the meeting of creditors in order to hold a vote on the arrangement forthwith after the inventory of receivable debts has been approved or the procedure of obtaining consent for granting public aid has been completed. Legislator assumed that twelve months should be enough for obtaining needed consents for granting public aid, approving the inventory of debts and for performance of the restructuring plan. Completing the restructuring measures is not inevitable before the meeting of the creditors. Performing the plan will be continued within the waiting time for the meeting and later after the validating of the arrangement. If the inventory of debts has been approved before the time of twelve months and the public aid is not needed or the consent has also been given the judge – commissioner should convene a meeting of creditors for the date the restructuring plan will have been performed or for the date suitable for the twelve months term of the opening of the remedial proceedings – whichever is earlier. It does not mean though, that the meeting cannot be convened before, especially if the debtor regained the ability to pay his dues (art. 3 par. 6 RestLaw) or the arrangement assumes liquidation. If after twelve months of the opening of the remedial proceedings the inventory of debts has not approved or the consent for granting public aid has not been given judge – commissioner must wait with convening the meeting of the creditors for both these procedures to be finished. The time limit provided in art. 3 par. 6 of the Restructuring Law is non-mandatory. The judge-commissioner shall notify the creditors entered into the inventory of receivable debts of the date of the meeting of creditors convened in order to adopt the arrangement, while serving on them the arrangement proposals, the information about the division of creditors entered in the inventory of receivable debts due to categories of interests, information about the manner of voting at the meeting of creditors and an instruction about the contents of proper regulations. Under art. 150 of the Restructuring Law the arrangement shall cover personal receivable debts arisen prior to the day of opening of restructuring proceedings unless otherwise provided in the act; interest for the period from the day of opening of restructuring proceedings and receivable debts contingent upon a condition

if the condition was fulfilled during the performance of the arrangement. Receivable debts in respect of a debtor under a mutual contract which was not performed in full or in part before the day of opening of restructuring proceedings shall be covered by an arrangement only in the case where the performance of the other party is a divisible performance and only to the extent in which the other party fulfilled the performance before the day of opening of restructuring proceedings and has not received mutual performance. The arrangement shall not cover: maintenance and alimony receivable debts and pensions constituting compensation for causing diseases, incapacity to work, disability or death and resulting from conversion of the rights covered by the substance of the right to annuity into pension for life; claims for release of the assets and abstention from infringement of rights; receivable debts for which the debtor is liable in connection with acquisition of inheritance after the day of opening of restructuring proceedings, after the inheritance was included in the arrangement estate or remedial estate and receivable debts resulting from social insurance premiums in the part financed by the insured, the remitter of which is the debtor. The arrangement shall not cover receivable debts under an employment relationship and receivable debts secured on the debtor's property by a mortgage, pledge, registered pledge, Treasury pledge or ship's mortgage, to the extent covered by the value of the object of security, unless the creditor expressed consent for covering the receivable debt by the arrangement. Consent for covering a receivable debt by the arrangement shall be expressed in an unconditional and irrevocable manner, no later than before commencement of voting on the arrangement. Consent may also be expressed verbally and recorded in the minutes of the meeting of creditors. The abovementioned rule shall apply accordingly to receivable debts secured by a transfer to a creditor of the ownership of a thing, receivable debt or another right. Covering by the arrangement of a receivable debt which is covered by another arrangement is inadmissible, unless said agreement has been revoked. Pursuant to article 150 par. 1 of the Restructuring Law the arrangement covers personal receivable debts arisen prior to the day of opening of restructuring proceedings. Personal receivable debts are receivable debts from the contractual relationship between the debtor and the creditor. The source of relationship is usually the contract, the tort or unjust enrichment. Non-personal receivable debts are not covered by the arrangement. Non-personal receivable debts are receivable debts of a creditor whose claim that can be directed at the debtor is the claim of drifting the execution from particular asset of the debtor. The example can be the liability of the mortgagor, which restricts only to the subject of the mortgage. If the owner of the immovable property is not personal debtor in case of the awarding from him to the creditor the mortgage sum of money the court should of its own motion reserve the debtor the right to claim limited liability in the course of execution (Judgement, 2014, legalis). Taking into consideration the date of the obligation the receivable debts may be divided into two groups – the debts which arose before the date of the opening of the remedial procedure and those which arose after that date. The arrangement covers all receivable debts which arose up to the end of the day before the opening of the remedial procedure. The receivable debts which arose in the day of opening of the remedial proceedings and later are not covered by the arrangement and should be met on an ongoing basis in the course of the proceedings and after its finishing with the exception of interest for the period from the day of opening of the restructuring proceedings which are covered by the arrangement also within the sum which arises after the date of opening of the remedial proceedings. The date of arising of the receivable debt is the decisive moment. According to the judgement of The Supreme Court, concluding and approving of the arrangement does not influence on the sole existence of the receivable debts but determines the limits of its execution or other ways of satisfying, being binding so long as the approved arrangement is binding and under the condition that is it performed (Judgement, 2013, Legalis).



#### 4. CONCLUSION

Remedial proceedings is a restructuring procedure that enables the debtor to continue the activity of an enterprise even in severe financial trouble. The main purpose of the proceedings is to avoid declaration of bankruptcy through enabling the debtor to undergo restructuring by making an arrangement with creditors and through conducting remedial actions, while securing legitimate rights of creditors. Remedial proceedings is dedicated to entrepreneurs who – due to different reasons – cannot conclude the arrangement with creditors in the course of the other restructuring proceedings. That may be first of all due to the fact that creditors see the debtor as unable to fulfill the conditions of proposed arrangement or the proposed arrangement may be not satisfactory to the creditors. Remedial proceedings, due to the possibility of using extraordinary legal measures (such as the possibility of withdrawing from the agreement which is not beneficial to the debtor, the possibility of adjusting the level of employment to the needs of the enterprise with the use of the competence that were restricted to the bankruptcy trustee before or the possibility of selling unnecessary assets of the enterprise with the result of the forced sale) enables the entrepreneur to improve the economic situation of the enterprise to such an extent that fulfilling the proposed arrangement is possible or it is possible to propose the creditors more beneficial conditions (Gurgul, 2018, Legalis). Filing the application to open remedial proceedings in the right time may rescue an insolvent enterprise or an enterprise threatened with insolvency through different measures that can be performed both at the stage of the proceedings for the opening of the remedial proceedings and at the stage of the proper remedial proceedings.

#### LITERATURE:

1. Adamus R. (2015) Commentary on art. 10 of the Restructuring Law. C. H. Beck/Legalis.
2. Filipiak P. (2016) Commentary on art. 285 of the Restructuring Law. Wolters Kluwer/Lex.
3. Gurgul S. (2018) Commentary on art. 283 of the Restructuring Law. C. H. Beck/Legalis.
4. Hrycaj A. (2016) Commentary on art. 286 of the Restructuring Law. C.H. Beck/Legalis.
5. Judgement of The Court of Appeal in Bialystok number I ACa 761/13. 14.05.2014. Legalis.
6. Judgement of The Supreme Court number V CSK 416/12. 15.03.2013. Legalis.
7. Justification to the project of the Restructuring Law, 2015, [www.gov.pl](http://www.gov.pl).
8. Malmuk-Cieplak A. (2016) Commentary on art. 285 of the Restructuring Law. Wolters Kluwer/Lex.
9. Witosz A. (2015) The administration in possession of the debtor in the Restructuring Law. *Studia Ekonomiczne. Zeszyty Naukowe Uniwersytetu Ekonomicznego w Katowicach*.
10. Zimmerman P. (2018) Commentary on art. 283 of the Restructuring Law. C. H. Beck/Legalis.
11. Zimmerman P. (2016), *The Bankruptcy Law. The restructuring Law. Commentary*. C.H. Beck.

# THE IMPACT OF WRITTEN CORRESPONDENCE ON BUILDING CUSTOMER RELATIONSHIP

**Izabela Ostrowska**

*University of Szczecin, Faculty of Management and Economics of Services, Poland  
izabela.ostrowska@wzieu.pl*

**Grazyna Rosa**

*University of Szczecin, Faculty of Management and Economics of Services, Poland  
grazyna.rosa@wzieu.pl*

**Kamila Slupinska**

*University of Szczecin, Faculty of Management and Economics of Services, Poland  
kamila.slupinska@wzieu.pl*

**Leszek Gracz**

*University of Szczecin, Faculty of Management and Economics of Services, Poland  
leszek.gracz@wzieu.pl*

## **ABSTRACT**

*Relationship marketing is the theory most associated with the Nordic School of Marketing, which deals with the issues of creating and strengthening the relationships of companies with clients, and also addresses the issues of customer satisfaction and their loyalty. The problem of building relationships has found practical applications due to the increasing competition on the market, causing the need to calculate the costs of acquiring new buyers and maintaining existing ones. Especially in mature industries, which include the energy supply market, companies try to take care of relationships with customers so that they do not leave them and do not use the offers of competing companies. Customer service is an important element in creating customer relations, especially an appropriate communication strategy. The aim of the article is to explain how to shape written communication in a company to build relationships with clients, and in particular to determine the key elements of correspondence important for the formation of relationships. The paper reviews the available literature and contains the results of a qualitative research conducted by the authors in a cooperation with a large energy company in Poland.*

**Keywords:** *Communication, Customer relationship, Qualitative research, Written correspondence*

## **1. INTRODUCTION**

A mature market forces a change in marketing strategy and developing relationships with clients served by the company. In such a market, acquiring new buyers becomes more and more difficult due to the tendency to stable demand at a certain level. Acquiring new customers means that you need to take them back from competition. Such a strategy requires large expenditures, and its effectiveness decreases, due to the growing costs of promotion with declining efficiency indicators. The aim of the article is to explain how to shape written communication in a company to build relationships with clients, and in particular to determine the key elements of correspondence important for the formation of relationships. This article is another publication from the series on written communication of a large organization (Rosa et al., 2018, Gracz et al., 2018, Ostrowska et al., 2018). L. Berry is considered to be the creator of relationship marketing. He referred to the concept of relationship marketing to the service sector, and research interests focused on the need to introduce a long-term perspective in the

company's marketing activities. In the first definitions of relationship marketing, this concept was mainly referred to the company's clients (Berry, Shostack, Upah, 1983, pp. 25-28). Currently, the use of relationship marketing is broader and also relates to relationships with other entities from the company's environment. This is illustrated by the model of six markets created by M. Christopher, A. Payne, D. Ballantyne, i.e. an expanded area on which a company implementing relationship marketing, should carry out marketing activities involving, in addition to the customer market, the supplier market, potential employees, intermediaries, influential institutions and the internal market (Christopher et al., 1991, pp. 20-31). The key significance of customers results from the fact that through common imperative of better understanding and meeting customer expectations, they cause the unification of activities of many interest groups and constitute the most important area of marketing strategy of the company (Mitreęa, 2005, p. 49). The specific justification for the implementation of relationship marketing was provided by research carried out by F.F. Reichheld and W.E. Sasser Jr. in 1990. The results of the survey show that the most loyal clients of the company are also the most profitable ones (Reichheld, Sasser, 1990). Subsequent research indicates that the profitability of the relationship on which companies care most depends on the long-term relationship and relationship costs (Stobracka, Standvick, Grönroos, 1994, pp. 26-28). According to E. Gummesson, the role of the company's creation of market relations and interactions in the marketing activities of the organization is of the essence (Gummesson, 1991, pp. 95-98). The importance of intangible assets grows as companies change their business profile from industrial and manufacturing to service and knowledge-based. Increasingly, one can notice postulates that the valuation of the company's value should take into account the value of customer relationships, because they largely affect the real value of the company (Blattberg et al., 2001, Boyce 2000, Brown, 2003, Kumar V., Rajan B. 2009, Łada, 2011, Ujwary-Gil, 2018, Urbanek, 2011).

## **2. CORRESPONDENCE AND BUILDING RELATIONSHIP**

The essence of relationship marketing is presented by M. Szymura-Tyc: relational marketing is about building lasting relationships with clients based on trust, two-way communication and listening to opinions of leading clients, in order to create products and services that meet their needs (Szymura-Tyc, 2000, p. 159). F. Webster believes that marketing must be responsible for creating a relationship with the client, i.e., it must be individual and interactive (Webster, 1992, p. 5). What is more, relationship marketing proposes that marketers must focus on long-term relationships with customers rather than single transactions (Krishnamurthy, 2000, p. 525). Creating a real loyalty of the buyer is not possible without creating a feeling of satisfaction with contacts with the company. The relationship between satisfaction and loyalty is a basic condition for building loyalty (Griffin, 1997; Mitreęa, 2005). High customer satisfaction favors the emergence of strong, emotional relationships with the company that go beyond reasonable preferences and shapes strong loyalty. Every customer's contact with the company, be it by telephone, personal or correspondence, must be equally satisfactory for him (Payne, 1997, p. 59). As rightly noted by J.R. Katzenbach and A. Santamaria success of many organizations, including service providers depends on the first line workers (1999, pp. 107-111). Employees of the company, in constant contact with buyers, may positively or negatively affect the perception of the whole enterprise by them (Gummesson, 2000, pp. 45-46). Customers, especially from the business segment, expect exceptional treatment, perception of individual preferences and help in solving their problems, as well as high level of service (Day G.S., 2003, pp. 78-79). Introducing a relationship marketing strategy requires standardization, also in the scope of mailing templates addressed to customers. In order to provide customized products and methods of communication on a massive scale, very precise schemes and procedures should be introduced (Plecner, Schröder, 2000, p. 28).

It is necessary to match the message, vocabulary and form to circumstances, so that by using this form of expression, communicate with its addressees in the best possible way (Simerson, Venn, 2010, p. 197). From the customer's perspective, the important aspects concern, among others, fairness in the tangible outcome, process, and interaction. Formal written letters that exhibit these qualities tend to be received more favorably (DeWitt, Drew, 2009, p. 362). Based on reader-writer relations, the writer is expected to indicate an appropriate level of respect and politeness (Zhu, Hildebrandt, 2013, p. 398). As emphasized by V. Eiriz, D. Wilson, the emphasis on comprehensive quality management is the common denominator of the various concepts of relationship marketing. Taking care of quality and attentive service, is in the opinion of these authors the basic condition for the company to be able to acquire customers and maintain long-term relationships with them (Eiriz V., Wilson D, 2006). A. Zeithaml, A. Parasuraman and L. Berry in the SERVQUAL model showing factors influencing customer perception of the quality of services, mention, among others: information about services, competence, respect for the customer, credibility, responsibility, type of material used, understanding the needs of buyers (Zeithaml V., Parasurman, Berry L, 1990, p. 16). These factors should be taken into account when creating correspondence addressed to customers. Efficient written communication, compliant with the highest standards in this field and the expectations of the addressees, is a very important element in building the relationship of a large organization with clients. The importance of communication is recognized in literature on B2B marketing and is often associated with building relations. In fact, communication is one of the most effective relationship building strategies and a key determinant of outcomes in business-to-business (B2B) relationships (Murphy, Sashi, 2018). Research by Raciti and Dagger showed four components of written communication that influence the development of customer relationships are: message clarity, aesthetics, accuracy and physical features. Communication plays an important role in sustaining customer relationships in so far as relationship marketing is largely about conveying to the customer how important they are to the service organisation and imparting a sense of closeness and intimacy that binds the relationship (Raciti, Dagger, 2010, pp. 103-111). Effective correspondence handling allows a firm to be responsive to and strengthen its relationship with customers to ensure their continued business and also to cultivate a valuable source of information (Smart, Martin, 1992, p. 105). In mass communication of a large company with consumers, there are two main communication channels allowing direct reach of a consumer: mass written correspondence and call center. As call centers are used primarily for selling the offers, the letters (messages, email and traditional letters) seem to be the main tool of communication and therefore relation building tool. In other study, such impact on relation was indicated in the case of banks - "interviewees agreed that the regular correspondence that they received from their banks such as letters, make them feel that the bank has a good system they can trust. These direct communication tools affect clearly their reliance towards their bank, particularly if these tools deliver accurate and clear information" (Sadek, Redding, Tantawi, 2015, p. 48). We can extrapolate these results to all customers whom day to day contact with a supplier is based on written correspondents mainly. Therefore taking into consideration opinions and views of customers on all the aspects of letters is a base for maintaining a successful relationship. The rule in relation marketing should be permission marketing, that is, obtaining consent from the client for contacts from the company. Permission relationships start with the consumer's explicit and active consent to receive commercial messages and always give consumers the possibility to stop receiving messages at any time (Tezinde, Smith, Murphy, 2002, p. 30). Communication in relationship marketing is treated as the transmission of information needed by the client, which is why it sets the frequency of meetings, sending directories, telephone contacts or presentations (Waśkowski, 2002, p. 8). Thanks to such information activities, a climate of understanding, openness to customer needs and real communication are created.

### **3. RESEARCH METHODOLOGY**

The author's research was conducted on May and June 2017 with the use of Focus Group Interview method (FGI) and In Depth Interview method (IDI). The respondents were individuals who are the consumers of a large energy company from Poland. The criteria for selecting the respondents included balanced factors, such as: gender, age, type of customer (individual or institutional). There were 5 FGIs and 5 In Depth Interviews conducted: with young individual consumers, (up to 40 years), with elder individual consumers (more than 40 years) and with institutional customers (FGI and IDI). The three research objectives were stated: Objective 1: The understanding of behavior and preferences of customers in the scope of written communication. Objective 2: The analysis of current state of written communication in the scope of layout. Objective 3: The analysis of chosen aspects of written communication in the scope of affordability and clarity.

### **4. DESCRIPTION OF THE RESEARCH CONCLUSION - ELEMENTS OF WRITTEN CORRESPONDENCE AFFECTING THE CONSTRUCTION OF RELATIONS**

#### **4.1. Correspondence frequency**

Correspondence with individual clients is more rare than with business clients and is usually limited to invoices or information about changes in tariffs sent several times a year. Individual clients are much worse at understanding the content of letters from an energy company. The presented models of correspondence were quite difficult, especially for the elderly. It is good that the company maintains contact with its clients, but the way in which the correspondence is constructed and the resulting sense of customer unimportance for the company is negatively affected by the relationship. Older people, to understand the content of letters addressed to them, often turn to the family for help or choose to visit the customer service in person. Young people admit that they do not read many letters, they only browse them and if the sender does not demand specific actions, they simply ignore such correspondence. Business clients more often apply for additional services or changes in contracts, hence correspondence with the energy company is more frequent. Understanding the content of most of the samples presented in the letters from the company was not a great difficulty for them. However, they also believe that in order to improve mutual relations, the correspondence should be shortened and simplified so that they do not have to devote so much time to understand them.

#### **4.2. Letterhead**

For all surveyed groups, letterhead is an important element affecting the perception of the company. By placing a company's logo in the header of the letter, the recipient of correspondence believes that it is easier to identify the sender and for this reason they feel safer. Symbols and choice of fonts that influence the perception of the company and may be an element enabling recognition of the brand are also important in marketing communication (Cvitić, Šimić, Horvat, 2014, pp. 49-50). The letterhead should contain in the footer all contact details so that the recipient can choose a convenient way of answering. Also, the address for mail correspondence is expected so that the recipient knows where he can send back the reply. The address is important especially for older people who do not use the Internet and have difficulty in accessing certain information. Despite the fact that young people and business clients prefer e-mail during communication, in their opinion the correspondence address of the company increases tangibility and affects the perception of the subject as a reliable partner.

#### **4.3. Length of correspondence**

Correspondence with corporations is difficult due to the formal language and the long waiting time for a response. The participants first of all paid attention to the legal paragraphs and the volume of letters that characterize the letters from the institution.

These are the elements that disturb them in the correspondence and make it difficult for them to communicate with each other. According to the study participants, the mistake is that the letters start with paragraphs. Regulations are indicated, and the solution to the problem is not directly stated. Such records are perceived by the respondents as scaring and disorienting the recipient, they certainly make it difficult to understand the content and create the impression of a company-potent relationship. According to the respondents, paragraphs may appear, but they may well be a supplement to the content, e.g. in the form of an annex or footnotes. Letters that build a positive relationship with the client should be focused on the recipient and his needs. The beginning of the correspondence should include the most important information for the client, for example "Positive decision on connecting to the network". All participants agreed that the letters should be short, specific, informing about one topic best. The language should be simplified, and all regulations should be placed into the footnotes at the end of the letter. The respondents pointed out that letter from companies should fit on one A4 sheet and be understandable for the average customer.

#### **4.4. The writer**

Written communication coming out of the company should be formulated in the first person of the plural, because the writer represents the company and presents its position. Returns such as "we have checked and analyzed" increase the credibility of the information provided. The correspondence signature is also important for building relationships. The modern form of "Sincerely service department" has been assessed negatively by the respondents because there is no specific person with whom the client can contact. Despite the awareness of the respondents that letters to clients in a large organization are sent on a mass scale and employees are not able to remember all the issues they deal with, they nevertheless believe that the person writing the letter should take responsibility for it. All respondents are aware that it would be difficult if each client was assigned a so-called customer's care, however, it would be the most convenient solution for them. For this reason, at least the person signed under the correspondence, according to them should know the matter. In their opinion, the content should be in contact, and preferably the information given to whom you can contact in a given case (a specific person, by name and surname). This information can also be placed at the signature. Thanks to the recipient's contact person, customers feel that they are treated individually.

#### **4.5. Individualization**

Recipients of correspondence consider written correspondence to be a more individualized type of communication than, for example, advertising leaflets. The company, writing to an individual customer, addresses the letter to the entity, so the letter itself should be individualized. The initial phrase should be adjusted, "Dear Sir" or "Dear Madam", but according to the respondents, the name and surname of the recipient should not be added. At the end, the phrase "Yours faithfully" is perceived positively, provided the signature of a specific person from the company is used. The respondents also expect to adapt all forms of politeness to the recipient and provide specific information related to their case. For example, the phrase "We inform you that we are verifying all matters carefully" has been negatively received by the respondents. Customers expect information addressed to them, so they suggested a change to: "Please be advised that your case (or your case) has been thoroughly analyzed." From the recipient's point of view, writing about a specific case regarding a given customer builds a relationship and a sense of being important to the company. Customers do not want to be treated as a template. If the letter writer refers to the contract or the date of signing the contract with the client, the person who writes the letter should enter it so that the client does not have to look for this information in his archives. If the company informs that it has changed data, it should write specifically what was previously and what has been changed.

The company's representatives should use the "logical filter" to the content of the letter (e.g. if the letter is an apology addressed to the client, then it should not be reprimanded, if the company terminates the contract for reasons attributable to the client, it should not include an invitation to further cooperation).

#### **4.6. Courtesy phrases**

The customer relations are also influenced by polite phrases that do not provide specific information. As the beginning, the phrase: "Thank you for contacting the company X". In conclusion: "We express our hope that the information provided fully explains the situation, and our further cooperation will be successful and in line with your expectations", "If you have additional questions, please contact us." These types of returns have been received as nice and creating a pleasant impression on the recipient. According to the respondents, polite phrases can occur regardless of the subject of the letter. The only objection of the respondents is not to exaggerate and avoid the phrases "heartily, with bows, with respect, etc.", as phrases are too familiar and suitable in correspondence at the private level. According to the respondents, polite phrases should be adequate to the situation of the client. For example, in the case of a reply to a complaint letter, it is much better to use "in response to the notification of ..." than "thank you for contacting".

#### **4.7. Communication channel**

Also, customizing the communication channel allows you to build relationships with clients. The individual groups surveyed have different habits and preferences as to contact with companies. For young people the worst option is to go to a stationary office in order to settle a matter with the company. Different habits have older people who prefer to go to the office rather than explain the matter in writing or wait on the helpline. Mature people paid attention to the inconvenience of helplines. On the helpline you have to wait and you are often switched several times before you get on a person who can help in a given matter. In addition, calls to helpline are usually more expensive than ordinary lines, they are called special numbers, and often the waiting time for a call to a consultant is a few or even a dozen minutes. According to mature people, it is better to go to the office and settle the matter in person rather than use the helpline. Young people and company representatives are most likely to receive electronic communication and contact via the helpline. The use of e-mail communication, according to the participants, allows for better management of your time. "We decide when we pick it up, it does not interfere with our schedule of the day and we do not have to wait for the helpline to find out something." The email sent from the company should be able to be responded. The customer's application should also be "to the information" of a given customer so that he can confirm that such a message has reached the company. The SMS correspondence from the company in the form of a reminder of the impending payment deadline, whether the deadline has been exceeded and the arrears appear is appreciated by all. Also, in this case, the way of communicating is important so that the client feels that it is a gentle reminder and not a warning or even a threat of debt collection.

#### **4.8. Dealing with customer's issue**

The so-called "moments of truth" significantly influence on the relationship with the client. "Moments of truth", means moments in which the customer turns to with an important problem for him and awaits the reaction of the company. An example could be a letter in which a customer asks an energy company to divide the payment for an overdue invoice into installments. By the respondents, this situation of the client was defined as difficult and requiring the company's involvement in solving the problem. Meanwhile, the energy company sends a standard letter of disagreement over installments.

The respondents rated the letter negatively because of the negative decision and the lack of a way out towards the client, for example, the lack of proposals for spreading into fewer installments. In addition, at the end of the correspondence, the phrase "We express hope for further cooperation" appeared. The respondents said that if the company refuses to help the client, then it should rather not count on further cooperation. Young people participating in the study stated that the client's supervisor would be useful in situations that are difficult for customers, such as not receiving an invoice, issuing a request for payment or switching off electricity. It should be a person with whom you can talk in such a situation, which will explain what are the procedures and what the client should do to resume delivery of services as soon as possible. From the customer's perspective such difficult moments are a test of the relationship with the company, whether its representatives try to help him and meet the needs of the client, or on the contrary meet with indifference and lack of understanding.

#### **4.9. Apologies**

All groups of respondents drew attention to the importance of letters containing apologies for the relationship with the company. The respondents admitted that they realize that especially a large company can make a mistake. However, if the client is inconvenienced because of this, then the company should apologize. The ending of the letter was well received: "We apologize for the situation. We will do our best so that the similar situation will not be repeated in the future. "In the opinion of the respondents, it is good to say that the company can admit to the error, because it" humanizes the company "and builds positive relationships.

#### **4.10. Customer friendly company**

The researched company used the logo and the slogan "customer-friendly company". Several people spontaneously paid attention to this slogan and referred to it by assessing individual company activities. The respondents believed that if a company praises the "pro-client" approach, such a slogan in their opinion obliges them to make greater efforts for the quality of the relationship and the way of communication. The respondents did not quite like the slogan for the image of the energy company being examined, which resulted from their own negative experiences with the company, but also from the opinions heard about the indifferent approach to the clients' problems. Especially, cases of disconnecting power to people who defaulted in payment for one invoice or negative responses to requests for spreading installment payments caused that customers did not perceive the company as customer-friendly. To sum up, a "customer-friendly company" is a good slogan, but it must be supported by facts, otherwise it causes dissonance and negative emotions in the recipient.

#### **4.11. Reminders and debt recovery**

The company's image is largely influenced by one's own negative experiences. Already at the initial stage of research, when providing spontaneous associations with the brand, in addition to the obvious statements like "electricity", "energy supplier" or "bills", there were also "debt collection", "complaints problems". After asking the respondents, it turned out that the problem situations took place a few years earlier, and still affected the relationship with the company. Negative customer experiences, in this case problems with unjustified claims for debt collection, strongly affect the perception of the brand. For this reason, caution in formulating the content of debt collection letters is recommended. The respondents would prefer delicate SMS reminders about the approaching payment date for the invoice, and if the deadline would also expire, the reminder on the basis of the "presumption of innocence" of the client, resulting from omission or inattention. According to the respondents, a reminder would be enough: "We would like to remind you about the outstanding invoice number ... in the amount ... and please settle it." Older people pointed out that in the case of non-payment for the previous account, this information should not be written in a small print on the invoice, but rather more



emphasized. The person should be informed if there is an underpayment, and not cut off the current that has been reported. Before sending a formal request for payment or even disconnecting the electricity, it is necessary to thoroughly verify the situation. It would be good if in a difficult situation for the client, a specific person was indicated in the letter, who would explain all doubts of the client and suggest a solution if he is unable to pay the payment. In the event of disconnection of electricity, with no fault on the part of the client, the respondents expect an apology and a proposal for compensation from the company. The relationship with the client is built on mutual respect and not exposing to unpleasantness or stress. For this reason, the collection of the overdue payment, especially in the first letter, according to the respondents, should be based on providing information about the lack of payment for the service, and not threat with the legal consequences. The vindication letter included the information about the need to send proof of payment. This is, according to the respondents, an unnecessary complication for the client, and in addition, older people noticed that not everyone uses e-mails and then it is necessary to provide an address to which they can send a photocopy of proof of payment. According to the respondents, the following information would suffice: "If you have already made a payment, please disregard this information". Then, people who have already settled the amount due do not have to take any action, which saves their time and affects the positive perception of the company.

#### **4.12. Ecology**

The company, encouraging to use the electronic version of the invoice, wrote about ecological standards and care for the natural environment. This has been noticed by customers who, however, are not willing to change their habits and give up the convenience. For all groups of respondents, invoices sent by post are preferred. Business clients expect invoices in paper form, due to the need to attach them to the documentation. An indirect output can have a PDF invoice attached to an e-mail, which must be printed by customers, but they expect additional benefits for such a solution (e.g. lower subscription fees). Mature people explain their aversion to invoices sent online, with the lack of access to the Internet and the possibility of forgetting about a given payment. Young people said that it is more convenient for them if the invoice comes in the mail and like older people are afraid of missing the message or forgetting about the payment. Some of the respondents expressed the opinion that a company that cares about environmental standards should use green paper for invoice printing. There was also an opinion that the letters should be on both sides of the paper, then the company can actually boast that it is ecological.

#### **4.13. Product advertising**

From the point of view of the consumer, the promotion is perceived as the company's communication with the market, and the consumer expects specific information to facilitate purchasing decisions. Therefore, the message should be specific, consistent and transmitted in due time (Rosa, 2013, p. 167). This approach to communication and the attempt to manipulate the buyer raises objections. Consumers quickly discover the company's goals and eliminate, minimize or take over control of activities that reduce the quality of their lives (Fournier S., Dobscha S., Mick D.G., 1998, pp. 43-48). Consumers are more and more sensitive to all kinds of unwanted information and fear of privacy violation may adversely affect the client's attitude, thereby disrupting the communication process and deteriorating mutual relations. It should be remembered that advertising messages are perceived negatively by some of the respondents. For example, older respondents expressed concern that if they provide a phone number to a company, then companies would send text messages they did not want. Business customers perceive advertising of company's products placed on the reverse side of the written communication as unprofessional, in their opinion it loses its rank.

## 5. CONCLUSION

Companies recognize that expanding market share by systematically acquiring new customers is virtually impossible on the mature market. Changing environmental conditions, above all the huge competition for buyers, cause companies to engage in such marketing activities that will limit the outflow of customers and allow them to build their loyalty. Consumer's loyalty is the result of entering a relationship marketing, it is based not only on the satisfaction of the product or service itself, but it is mainly achieved through the creation of emotional relations between the supplier and the customer. Customers want to be treated individually and such activities of the company build relationships, encourage them to be loyal. Individual approach is demonstrated by direct contact with the customer and interactive communication. Communication should provide the client with values, because only then can he build relationships. Clients appreciate communication if they receive information that is interesting to them, through such communication channels that they are eager to use and at a convenient time. In the opinion of all surveyed consumer groups, a positive impact on mutual relations would be affected by simplifying the language of correspondence and shortening the content of the letters so that they can read and understand them more quickly. It is worth remembering that the correspondence with clients allows not only to provide information and receive answers, but also creates the possibility of creating a sense of community and distinguishing the client, thus creating closer relations with the consumer.

## LITERATURE:

1. Berry L. (1983). *Relationship Marketing* [In:] Berry L., Shostack G.L., Upah G.D., *Emerging Perspectives on Services Marketing*. Chicago: American Marketing Association.
2. Blattberg R.C., Getz G, Thomas J.S. (2001). *Customer Equity: Building and Managing Relationships as Valuable Assets*. Boston: HBS Press.
3. Boyce G. (2000). Valuing Customers And Loyalty: The Rhetoric Of Customer Focus Versus The Reality Of Alienation And Exclusion Of (Devalued) Customer. *Critical Perspectives on Accounting* No 11.
4. Brown S.A. (2003). *Strategiczne podejście do klientów*. Warszawa: PWE.
5. Christopher M., Payne A. , Ballantyne D. (1991). *Relationship Marketing – Bringing Quality, Customer Service and Marketing Together*. Oxford: Butterworth Heinemann.
6. Cvitić F., Šimić M.L., Horvat J. (2014), Genesis, visual attributes and contemporary communication features of the alphabet. *Review of Contemporary Entrepreneurship, Business, and Economic Issues*, Vol. XXVII.
7. Day G. S. (2003). Creating a Superior Customer-Relating Capability, *Sloan Management Review* vol. 44 No. 3.
8. DeWitt T., Drew M. (2009) Writing a credible form letter: implications for hospitality and tourism service recovery strategy. *International Journal of Culture, Tourism and Hospitality Research*; Bradford Vol 3, No 4
9. Eiriz V., Wilson D. (2006). Research in Relationship Marketing: Antecedens, Traditions and Integration. *European Journal of Marketing* 2006. No. 3-4.
10. Fournier S., Dobscha S., Mick D.G. (1998). Preventing the Premature Death of Relationship Marketing. *Harvard Business Review* January-February 1998.
11. Gracz L., Rosa G., Ostrowska I., Słupińska K. (2018). *Written communication of a large organization with institutional customers*. 32nd International Scientific Conference on Economic and Social Development: book of proceedings, (ed.) A.V. Kovrov, O. A. Popov, A. Ceh Casni.
12. Griffin J. (1997). *Customer Loyalty. How to Earn It How to Keep It*. San Francisco: Josser-Bass Publishers.
13. Gummesson E (1991). Marketing – Orientation Revised. The Crucial Role of the Part-time Marketer, *European Journal of Marketing* No. 2.

14. Gummesson E. (2000). *Total Relationship Marketing. Rethinking Marketing Management*. Oxford: Butterworth-Heinemann.
15. Katzenbach J., Santamaria J. (1999). Firing up the front line. *Harvard Business Review*. May-June.
16. Krishnamurthy S., (2000). Permission Marketing: Turning Strangers Into Friends, And Friends Into Customers. *JMR, Journal of Marketing Research*; Chicago Vol 37, No 4.
17. Kumar V., Rajan B (2009). *Profitable Customer Management: Measuring and Maximizing Customer Lifetime Value. Management Accounting Quarterly* 2009, Vol 10, No. 3.
18. Łada M. (2011). Pomiar ekonomiczny zorientowany na relacje z klientami we współczesnej rachunkowości. *Prace Naukowe Uniwersytet Ekonomiczny w Katowicach*, No. 246.
19. Mitreęga M. (2005). *Marketing relacji – teoria i praktyka*. Warszawa: CeDeWu.pl.
20. Murphy M., Sashi C.M. (2018). Communication, interactivity, and satisfaction in B2B relationships. *Industrial Marketing Management* 68.
21. Ostrowska I., Rosa G., Gracz L., Słupińska K, (2018). *Written communication of a large organization with young consumer*. 30th International Scientific Conference on Economic and Social Development: book of proceedings, (ed) K. Hammes, I. Klopotań, M.Nestorovic.
22. Payne A. (1997). *Marketing usług*. Warszawa: PWE.
23. Plencler J., Schroder A. (2000). Marketing partnerski. *Marketing w Praktyce*, No. 3.
24. Raciti M.M., Dagger T.S. (2010). Embedding relationship cues in written communication. *Journal of Services Marketing* No. 24/2.
25. Reichheld F.F., Sasser W.E. Jr. (1990). Zero Defects: Quality comes to service. *Harvard Business Review*. No. 9-10.
26. Rosa G. (2013). *Konkurencja na rynku usług transportowych*. Warszawa: Wydawnictwo C.H Beck.
27. Rosa G., Gracz L., Ostrowska I., Słupińska K. (2018). *Written communication of a large organization with mature consumers*, 31st International Scientific Conference on Economic and Social Development: Legal Challenges of Modern World: book of proceedings, (ed) M. Cingula, D. Rhein, M. Machrafi.
28. Sadek H., Redding P., Tantawi P. (2015). Investigating the major marketing communication tools and their impact on building bank brand equity in the Egyptian context A customer perspective. *Journal of Business and Retail Management Research*. London Vol 10, No. 1.
29. Simerson B.K., Venn M.L. (2010). *Menedżer jako lider*. Warszawa: Oficyna a Wolters Kluwer business.
30. Smart D.T., Martin Ch.L. (1992). Manufacturer Responsiveness to Consumer Correspondence: An Empirical Investigation of Consumer Perceptions. *The Journal of Consumer Affairs*. Madison Vol 26, No. 1.
31. Stobracka K. , Strandvik T., Grönroos Ch. (1994). Managing customer relationship for profit. *International Journal of Service Industry Management* No. 5.
32. Szymura-Tyc M. (2000). Wartość dla klienta jako podstawa budowy przewagi konkurencyjnej przedsiębiorstw. *Prace Naukowe AE Wrocław* No. 852. Wrocław.
33. Waśkowski Z. (2002). Zastosowanie marketingu partnerskiego w budowie trwałych więzi z klientami. *Marketing i Rynek* No. 2.
34. Tezinde T., Smith B., Murphy J. (2002). Getting permission: Exploring factors affecting permission marketing. *Journal of Interactive Marketing*. Philadelphia Vol 16, Issue 4.
35. Ujwary-Gil A. (2018). *Kapitał intelektualny a wartość rynkowa przedsiębiorstwa*. Warszawa: Beck.
36. Urbanek G. (2011). *Kompetencje a wartość przedsiębiorstwa*. Warszawa: Wolters Kluwer.
37. Webster F. (1992). The changing role of Marketing within the Corporation, *Journal of Marketing* No. 9.
38. Zhu Y., Hildebrandt H. (2013) Effective Persuasion of International Business Sales Letters: An Emic-etic Perspective. *Management International Review*. Wiesbaden, Vol 53, No. 3.

## FIGHT AGAINST DOMESTIC VIOLENCE IN REPUBLIC OF CROATIA AND THE REPUBLIC OF SERBIA

**Vanda Bozic**

*Department of Criminal Law, Faculty of Law, Zagreb  
vanda.bozic@pravo.hr*

**Zeljko Nikac**

*The Academy of Criminalistic and Police Studies, Belgrade  
zeljko.nikac@kpa.edu.rs*

### **ABSTRACT**

*The phenomenon of domestic violence has been known from the earliest days of human civilization and has only recently been studied, no longer as a private, but as a social and public category. In accordance with the international standards the EU countries (Croatia) have adopted adequate legislation to combat domestic violence. Similarly, Serbia has acted as a candidate country for EU accession. The paper deals with more important international legal sources and EU standards for combating domestic violence, among which a significant place belongs to the Istanbul Convention. Criminal offenses of domestic violence envisaged by the criminal law of Croatia and Serbia have been specifically addressed. Other legal sources for the prevention of domestic violence were also pointed out and research was conducted on the types of domestic violence committed against women on the territory of Croatia and Serbia. The conclusion provides the de lege ferenda proposals for improvement of legal solutions in the function of prevention of domestic violence.*

**Keywords:** *domestic violence, criminal liability, legislation, Croatia, Serbia*

### **1. INTRODUCTION**

The global problem of domestic violence, known from the earliest days of human civilization, has long been socially acceptable in the cultures of different peoples. As a rule, the main holders of domestic violence are male since the men had a dominant position in society and in the family. The patriarchal system had at its center the dominance of men over women and children. They were in fact the owners of their life and survival. In this context, various types of restrictions and prohibitions have been introduced for women and children that have influenced their lives. Until recently, domestic violence was perceived as a private family affair, and the state could not interfere in these relations, which contributed to further inequality and discrimination of women and children.<sup>1</sup> The next consequence was the prevention of further and full progress of women in their work and status-legal position in society, in which way discrimination was even more deepened. With the development of modern society, the issue of domestic violence is no longer seen as a private and family matter, but as a public and social problem that has significant consequences and is gaining a wider dimension.<sup>2</sup> The most important initial step was a historical case from the USA (Case Alabama and Massachusetts, 1881) when a ban was imposed on men to punish women and children and the term domestic violence was officially used for the first time.<sup>3</sup> Further development of society contributed to a better overall position of women and children in the community. Particularly noticeable was the progress after the Second World War when the international community started on the path of material and spiritual rebuilding of the wrecked states. In the field of 'women' and family rights greatest progress has been made through the work of the most important international

---

<sup>1</sup> More: Zloković J, *Nasilje nad roditeljima – Obiteljska tajna?*, Grafika Zambelli, Rijeka, 2009.

<sup>2</sup> Ajduković M, *Određenje i oblici nasilja u obitelji*, Društvo za psihološku pomoć, Zagreb, 2000, p.11-15.

<sup>3</sup> Ajduković M, *Obilježja žrtvi i počinitelja obiteljskog nasilja*, Društvo za psihološku pomoć, Zagreb, 2000, p.89-92.

organizations such as the UN, the CoE and the EU today. Several significant international conventions, resolutions and other acts have been adopted highlighting the equality of women and children with men in society against all forms of discrimination and segregation. The member states of these organizations signed and ratified numerous international documents on the basis of which their national legislations were revised, adopted international standards and envisaged measures to combat domestic violence. The criminal justice response encompassed the adoption of specific criminal law norms, the establishment of specialized bodies and mechanisms to combat domestic violence. The fight against domestic violence in Croatia today is part of the overall effort and activities undertaken in the context of EU membership. There is a somewhat similar situation in Serbia, which is a candidate country for EU accession, and is in the process of harmonizing legislation with EU regulations, adopting the *acquis* and best practice. The problem of combating domestic violence in these countries and the region is even more complicated given the consequences of past conflict, transition and enormous development of the most serious forms of organized crime.<sup>4</sup> Under the strong influence of the progressive public, the problem of domestic violence today is no longer a private matter of individuals and families, but a very important public and social issue that has wider repercussions and requires a harmonized legal and factual response of the state and the international community as a whole.

## 2. CONCEPT AND FORMS OF DOMESTIC VIOLENCE

- a) In doctrine and practice for a long time there is no single conceptual definition of the phenomenon of domestic violence, but there are many different perspectives and definitions. Medical concept starts with the International Classification of Diseases, which, among other things, determines the medical characteristics of the event and gives a clinical description of the consequences. Sociological standpoint in particular states the causes and consequences of violence, the dynamics of events and other circumstances, and emphasizes the importance of prevention and assistance to victims (injured). Legal standpoint highlights the criminal procedure and sanctioning of perpetrators in the foreground, and in that context it is important to obtain valid evidence for the prosecution of crimes and perpetrators.<sup>5</sup> Of course, in doctrine there are also different views on the problem of domestic violence such as the subjective approach.<sup>6</sup> Domestic violence needs to be determined by respecting legislative solutions in the norms of international and national law, with respect for medical and sociological elements.
  
- b) The Law on Protection from Domestic Violence of Republic of Croatia defines domestic violence as any form of physical, psychological, sexual or economic violence.<sup>7</sup> In this context, the main characteristic of domestic violence is the effort of a family member, usually a man, to use force or threat, intimidate or otherwise establish control over family members and to maintain such a state. In the temporal sense, domestic violence is a condition that usually lasts for a prolonged period with a clear tendency of frequent repetition and continuity.<sup>8</sup> We add that the Criminal Code of the Republic of Croatia (CC RC) specially criminalizes the criminal offense of Domestic Violence.<sup>9</sup> In the Criminal Code of Republic of Serbia (CC RS) domestic violence is foreseen as an offense in Art.194

---

<sup>4</sup> Božić V, *Suzbijanje organiziranog kriminaliteta u svjetlu pozitivnog kaznenog zakonodavstva Republike Hrvatske*, Zbornik „Suzbijanje organizovanog kriminala kao preduslov vladavine prava“, Institut za uporedno pravo, Vršac, 2016, p. 285-300.

<sup>5</sup> More: Rajter M, *Obiteljski stresori i obilježja obitelji kao prediktori roditeljskog nasilja nad djecom*, doktorski rad, Pravni fakultet Sveučilišta u Zagrebu, 2013.

<sup>6</sup> Pećnik N, *Međugeneracijski prijenos zlostavljanja djece*, 2 izd. Naklada Slap, Jastrebarsko, 2005, p.272.

<sup>7</sup> Law on Protection from Domestic Violence RC, OG no137/09, 14/10, 60/10

<sup>8</sup> Kolesarić J, Kolesarić D, Hečimović I. i Paripović S, *I will – I know – I can*, SOS Priručnik, Virovitica, 2014 available at: <http://sosvt.hr/wp-content/uploads/2014/10/I-will-I-know-I-can-priru%C4%8Dnik.pdf>, (28.09.2018)

<sup>9</sup> Art.179.a. Criminal Code RC, OG no. 61/15, 101/17

CC and defined as any form of force or threat of attack on a life or body, with arrogant or ruthless behavior endangering serenity, bodily integrity or the mental state of a family member. Aggravated forms of offenses of domestic violence are foreseen for the use of weapons or other dangerous tools and the occurrence of severe bodily injury or death of a family member.<sup>10</sup> The fight against domestic violence is more closely regulated by the provisions of the Law on the Elimination of Domestic Violence.<sup>11</sup>

- c) Emergent forms of domestic violence are numerous and are cited according to different criteria. Thus, in relation to the victims of violence, there is violence against: partners (especially women), older people and children.<sup>12</sup> In doctrine and practice, the most common forms of family violence are determined according to the object of protection: physical, emotional, sexual and economic violence.
- Physical violence is "any intentional physical assault or bodily contact that endangers, injures, or exposes the person to physical pain or death that could be avoided".<sup>13</sup> From the point of view of the mode of execution, this is a specific form of violence against the victim that manifests itself in the form of pushing, kicking, slapping, weapon use, murder or attempted murder, destruction of property, denial of physiological needs and refusal to provide assistance.<sup>14</sup> Particularly dangerous form is physical violence against children in the family, in the form of bodily injury to an underage child, especially in unusual places on the body that could not be caused by accidental injury.<sup>15</sup>
  - Emotional violence encompasses a negative verbal or non-verbal attitude towards the victim as a psychological pain manifested in the sense of prohibition, threats, insults, and other acts that adversely affect personality and mental health.
  - Sexual violence represents "any coercion, exploitation, or soliciting incest, intimate physical contact, and any sexual activity that the person does not want or can not decide on for whatever reason".<sup>16</sup>
  - Economic violence is concerned with taking financial income and preventing the victim from using financial resources, while in terms of economic abuse of a child the parent refuses to work, irresponsibly consumes funds or earns no living.<sup>17</sup>
  - Child neglect is a special form of family violence that is defined as "the lack of proper care and care of adults towards a child that significantly affects the child's normal physical and mental development."<sup>18</sup> It can be: physical, health, emotional, educational and neglect of a child with special needs.<sup>19</sup>
  - Neglect of the elderly is a modality of neglect of a family member, but very special because it is about people who have specific needs according to age.

---

<sup>10</sup> Art. 194.p.2-4., Op.cit. in note 11.

<sup>11</sup> Law on the Elimination of Domestic Violence, OG no.94/16

<sup>12</sup> Calvete E, Orue I, *Cognitive Mechanisms of the Transmission of Violence: Exploring Gender Differences among Adolescents Exposed to Family Violence*. Journal of Family Violence, 28(1), Springer, USA, North Carolina, 2013, p.73-84.

<sup>13</sup> Op.cit. in note 2, p.55.

<sup>14</sup> Ajduković M, Mamula M, Pečnik N, Tolle N, *Nasilje u partnerskim odnosima*, Društvo za psihološku pomoć, Zagreb, 2000, p.57-68.

<sup>15</sup> More: Bilić V, Buljan-Flander G, Hrpka H, *Nasilje nad djecom i među djecom*. Naklada Slap, Jastrebarsko, 2000

<sup>16</sup> Op.cit. in note 1. p.61.

<sup>17</sup> Op.cit. in note 8.

<sup>18</sup> Buljan-Flander G, Kocijan-Hercigonja D, *Zlostavljanje i zanemarivanje djece*, Marko M. usluge d.o.o., Zagreb, 2003, p.65.

<sup>19</sup> Op.cit. in note 2. p.11-15.

### 3. IMPORTANT INTERNATIONAL SOURCES FOR COMBATING DOMESTIC VIOLENCE

- a) Under the auspices of the UN adopted was the 1979 Convention on the Elimination of All Forms of Discrimination Against Women - CEDAW, which came into force at the end of 1981.<sup>20</sup> For the purpose of its application later was adopted the Optional Protocol to the Convention on the Elimination of All Forms of Discrimination against Women.<sup>21</sup> The Convention defines the discrimination of women as „any distinction, exclusion or restriction made on the basis of sex which has the effect or purpose of impairing or nullifying the recognition, enjoyment or exercise by women, irrespective of their marital status, on a basis of equality of men and women, of human rights and fundamental freedoms in the political, economic, social, cultural, civil or any other field.“<sup>22</sup> Discrimination based on gender is evident in relation to marital and family status, pregnancy and motherhood, parenting and sexual orientation. Convention envisages the obligations of signatory states in terms of harmonizing regulations, ensuring protection against discrimination and adopting measures, affirming gender equality and human rights. States may take provisional measures that have non-discriminatory and temporary character as well as limited duration. The signatories have an obligation to adopt measures to change the cultural patterns of gender inequality and the education of family members regarding the social function of motherhood, child raising and upbringing. Particularly significant is the taking of measures to combat trafficking in women, sexual exploitation and prostitution and ending discrimination in public life, voting rights and association. Equal representation of women in delegations, acquisition of citizenship, education, employment and professional status, healthcare, economic status, special position of rural women, equality before law and marital equality are also included in this context.<sup>23</sup> Of particular importance is the CEDAW Committee to abolish all forms of discrimination against women who has the authority to decide on individual complaints, as well as to initiate proceedings on their own initiative when it comes to serious and systematic violations of women's rights.<sup>24</sup> In any case, the solutions established by CEDAW have contributed to improving the overall position of women in society, eliminating all forms of discrimination, and exercising the right to marital and family relationships.<sup>25</sup> The UN Convention on the Rights of the Child, 1989<sup>26</sup> is a significant international act in the protection of children from domestic violence, highlighting the natural rights of children, the right to life and health. States have an obligation to enact measures regarding social welfare and protection of children from all forms of violence, abuse and abuse as well as rehabilitation of children victims of domestic violence. There is a significant role of the Children's Rights Committee, whose main task is to ensure the protection of children, their physical and mental upbringing within the family and in the community. The following documents were adopted within the framework of the UN: Recommendation No 19 of the Committee on the Elimination of Discrimination against Women, the Declaration on the Elimination of Violence against Women, the Beijing

---

<sup>20</sup> The Convention was also ratified by the former SFRY, OG SFRJ – IA, no 11/81

<sup>21</sup> Optional Protocol to the Convention on the Elimination of All Forms of Discrimination against Women, 22.12.1999. available at: [http://www.un.org.yu/pdf\\_int\\_konv/int\\_hr\\_conv/CEDAW Optional Protocol-Serbian.pdf](http://www.un.org.yu/pdf_int_konv/int_hr_conv/CEDAW%20Optional%20Protocol-Serbian.pdf), (10.11.2018.)

<sup>22</sup> Art.1. Op.cit. in note 20.

<sup>23</sup> UN Convention on the Elimination of All Forms of Discrimination Against Women – CEDAW, Available at: <http://www.un.org/womenwatch/daw/cedaw/text/econvention.htm>, (10.11.2018)

<sup>24</sup> Op.cit. in note 21. art.1, art.8.

<sup>25</sup> Radić I, Radina A, *Zaštita od nasilja u obitelji: obiteljskopравни, prekršajnopравни i kazneno pravni aspekt*, Pravni fakultet, Zbornik radova, 3/2014, Split, p.727.- 754.

<sup>26</sup> UN Convention on the Rights of the Child, adopted 20 th November 1989, OG SFRJ no 15/90, OG RC-IA no 12/93, 20/97

Declaration and Platform for Action and the Resolution of the Commission on Human Rights 2003/45 on the Elimination of Violence against Women.<sup>27</sup>

- b) Istanbul Convention CoE (Convention on the Prevention and Combating of Violence against Women and Domestic Violence, 2011) is the most important document of a recent date in the fight against violence against women, children and the family. The document defines the basic concepts in terms of family violence, defines the notion of domestic violence, includes offenders and victims of both sexes, regulates child abuse, elderly persons and partners, specifies support measures for victims. Domestic violence refers to all acts of physical, sexual, psychological or economic violence occurring in the family or in the household or between former or current spouses or partners, regardless of whether or not the perpetrator had the same residence as the victim. (art.3b). Violence against women implies a violation of human rights and the form of discrimination against women who as a consequence have or will have physical, sexual, psychological or economic harm or suffering, including threats of such acts, forcible or deliberate confiscation of liberty, whether in public or private life (art.3a).<sup>28</sup> The Convention has affirmed international standards, highlighting the criminal justice response to acts of domestic violence, measures of social support to victims and overseeing the implementation of the Convention through the Committee of Independent Experts. Special mention is made of the investigation, criminal prosecution, procedural law and protective measures, as well as migration and asylum. Finally, the need to establish the international cooperation of the signatory states in the function of combating domestic violence is emphasized, in which way this issue has received a strong international dimension. The convention had great significance because it raised the awareness of the community and citizens about the dimensions of the problem of domestic violence, women and children. Under the auspices of the CoE, the Convention for the Protection of Human Rights and Fundamental Freedoms (1950) was adopted earlier, which in the broader sense affirms gender equality and equality of women and men. The provisions of the Convention guarantee the right to life, personal security, private and family life, forbid torture, inhuman or degrading treatment and discrimination. European Court of Human Rights (ECHR) has largely contributed to the protection of human rights and freedoms through its work and court practice. The Court made several significant judgments and adopted a number of legal positions with strong legal arguments that domestic violence constitutes a violation of fundamental human rights.<sup>29</sup> Accordingly, any violence against women or child abuse justifies state intervention in terms of parental care and contacts with children.

## 4. FIGHT AGAINST DOMESTIC VIOLENCE IN CROATIA AND SERBIA

### 4.1. Republic of Croatia

- a) Domestic Violence existed as a criminal offense under the new Criminal Code of 2000<sup>30</sup> until 2013<sup>31</sup> when Criminal Code no longer criminalized domestic violence as an independent criminal offense but as a violation of The Law on Protection from Domestic

---

<sup>27</sup> More: Group of authors, *Nasilje nad ženama - prepreka razvoju*, International documents, *Autonomni ženski centar*, Belgrade, 2005.

Available at: <http://www.womenngo.org.rs/publikacije-dp/medjunarodni%20dokumenti.pdf>, (10.11.2018.)

<sup>28</sup> CoE Convention on preventing and combating violence against women and domestic violence, CETS No. 210.

<sup>29</sup> Van Bueren G, *Child rights in Europe*, Council of Europe, December 2007, p.121.

<sup>30</sup> A family member who uses violence, harassment or particularly insolent conduct puts another family member into a humiliating position shall be punished by imprisonment from 3 months to 3 years. More: Grozdanić V, Škorić M, Vinja I: *Nasilje u obitelji u svjetlu promjena Kaznenog zakona*, HLJKPP, Zagreb, vol. 17, no 2/2010, p. 669-698.

Novels of the Criminal Code of 2006. Punishment is tightened to a prison term of six months to five years in prison. Act on Amendments to the Criminal Code, OG no.71/06

<sup>31</sup> Criminal code RC, OG no. 125/11, 144/12



Violence.<sup>32</sup> However, the aforementioned solution proved inadequate in practice because the victims of domestic violence only had partial protection compared to that what they could have otherwise achieved through misdemeanor law. Re-criminalization of domestic violence was introduced in the Law on Amendments to the Criminal Code in May 2015, art. 179.a.<sup>33</sup> By introducing this incrimination, domestic violence also enters the domain of misdemeanor and criminal legislation, however, the border between the criminal offense and misdemeanor of domestic violence is not clearly defined, since there is no strict distinction between serious and mild violations of the provisions of The Law on Protection from Domestic Violence. The crime of domestic violence makes who cumulatively fulfill two requirements: it severely violates the regulations on protection against domestic violence and with this causes a family member or a close person to fear for their safety or security or to bring them into a humiliating position. The law is for the perpetrators prescribes imprisonment up to three years. The criminalization of domestic violence indicates a blanket and subsidiary criminal offense because it violates the provisions of the Law on Protection from Domestic Violence, which will be committed only if criminal acts have not committed a criminal offense not serious. The Criminal Code mentions which persons are considered family members, and which are referred to as close persons. This division is shown in Table 1.

<b>FAMILY MEMBERS</b>	<b>CLOSE PERSONS</b>
spouse	family members
common-law partner	former spouse
life partner	common-law partner
informal life partner	ex life partner
common children of the partners	informal life partner
blood relative in a direct line	persons who have a common child
relative in an indirect line up to the third degree	people who live in a common household
relative in an indirect line up to second degree	
adoptive parent	
adopted child	

*Table 1: Family members and close persons*

Common-law partner is a person living in common-law marriage, which has a permanent character or takes a shorter time if a common child is born,<sup>34</sup> while the informal life partner is a person living in a same-sex union, which has a more permanent character.<sup>35</sup> It can be noticed that Family law does not provide protection from violence to informal life partners.

- b) Subsidiary Criminal Legislation of the Republic of Croatia encompasses several regulations relevant to the fight against domestic violence. The Criminal Procedure Act<sup>36</sup> and the Juvenile Court Act<sup>37</sup> prescribe measures to protect the safety and privacy of the personal and family life of witnesses and victims. The regulations envisage precautionary measures, detention, a special way of examining witnesses in the proceedings, limiting public exclusion and other legal protection mechanisms.

<sup>32</sup> Law on Protection from Domestic Violence RC, OG no. 137/09, 60/10

<sup>33</sup> Criminal code RC, OG no. 61/15, 101/17

<sup>34</sup> art.87.par.10. CC RC

<sup>35</sup> *Ibid.* par.11.

<sup>36</sup> Criminal Procedure Act RC, OG no 110/97, 112/99, 58/02, 62/03, 115/06, 152/08, 76/09

<sup>37</sup> Juvenile Court Act RC, OG no 111/97, 27/98, 12/02

The Witness Protection Act<sup>38</sup> cites the protection measures of witnesses and victims outside the criminal procedure: physical and technical protection, displacement, concealment of identity and ownership and change of identity. Law on Compensation for Victims of Crime<sup>39</sup> provides for the right to compensation in cases of violence committed with intent and preconditions, procedure and the competent authorities for the right to compensation in the country and in cross-border cases. The Law on Police Affairs and Authorities<sup>41</sup> is a regulation that highlights the multi-agency approach and police cooperation with various bodies, organizations, communities, associations and citizens. It affirms the idea of partnerships in the community and emphasizes the special sensibility of children, juveniles, the elderly, the disabled and people with disabilities, as well as the victims of criminal offenses and misdemeanors. The Protocol on the Treatment of Domestic Violence<sup>42</sup> is a by-law that envisages measures by competent bodies in the treatment, forms, content and method of co-operation of bodies involved in the detection and suppression of violence, and the provision of assistance and protection of victims. Special attention is paid to children victims of violence or witnesses of domestic violence.

- c) In addition to the criminal legislation on combating family violence, the decisions adopted by other regulations also contribute. In the first place, this is the Constitution of the Republic of Croatia as a *lex generalis* regulation and several *lex specialis* regulations in the area of family law, gender equality, prohibition of discrimination and special protection of children. Constitution of the Republic of Croatia guarantees all citizens the enjoyment and protection of universal values such as: right to life, inviolability of freedom and personality, equality before the law, courts and bodies with public powers, right to personal and family life, dignity, equality before the law. Every abuse is prohibited and any form of discrimination based on sex, birth and social status. Particularly emphasized is the obligation of the state to protect maternity, children and young people and create conditions for a decent human life and to provide special care for minors without parental care. Established is the general obligation of all social actors in the community to protect children and the infirm.<sup>43</sup> Family law<sup>44</sup> in the chapter "The rights and duties in the relationship between parents and children," lays down measures to protect the rights and welfare of the child in cases of neglect, negligent treatment or maltreatment of a child. The law states abuses and gross violations of parental responsibility, duties and rights of the child, physical or mental violence against a child, violence against adult members of the family, sexual exploitation of the child, exploitation of the child by forced labor or excessive work, allowing the child to enjoy alcohol, drugs or other narcotics, implicating a child into socially unacceptable behavior, leaving the child, care for a child with whom he or she lives for longer than 3 months, the absence of conditions for a common life with a child who does not live within 1 year without a particularly justified reason, lack of care for the basic life needs of a child with or without respect for measures the welfare of the child was brought before the competent authority as well as every other form of gross violation of children's rights.<sup>45</sup> The Gender Equality Act<sup>46</sup> provides for a general prohibition of discrimination based on gender, marital or family

---

<sup>38</sup> Witness Protection Act RC, OG no 163/03

<sup>39</sup> Law on Compensation for Victims of Crime RC, OG no 80/08

<sup>41</sup> Law on Police Affairs and Authorities RC, OG no 76/09

<sup>42</sup> Protocol on the Treatment of Domestic Violence, available at:  
<http://www.mspm.hr/UserDocsImages/djeca%20i%20obitelj/Protokol-o-postupanju-u-slucaju-nasilja-u-obitelji.pdf>,  
(20.10.2018.)

<sup>43</sup> Constitution of the Republic of Croatia, OG no 85/10, 05/14

<sup>44</sup> Family law RC, OG no 110/97, 27/98, 50/00, 129/00, 51/01, 111/03, 190/03, 105/04, 84/05, 71/06, 110/07, 152/08

<sup>45</sup> Art.114.par.2. *Ibid.*

<sup>46</sup> Gender Equality Act RC, OG no 82/08

status and sexual orientation. Discrimination is also considered to be more unfavorable treatment for women on the basis of pregnancy and maternity. The principle of gender equality is emphasized in terms of: employment and labor, education, media commitments in promoting awareness of equality between men and women, data collection for statistical purposes and action of political shortages. The Anti-Discrimination Act<sup>47</sup> provides for protection against discrimination based on gender, race, ethnicity, color, language, religion, political or other belief, national or social origin, property status, union membership, education, social status, marital or family status age, health status, disability, genetic heritage, gender identity, expression or sexual orientation. The Ombudsman Act for Children protects the rights and interests of children as the most vulnerable social group.<sup>48</sup> The Ombudsman is authorized to file a complaint with the State Attorney's Office, warn the Center for Social Welfare and propose measures to protect the rights and interests of the child in case the child is subjected to violence or abuse.<sup>49</sup> The Law on Protection from Domestic Violence<sup>50</sup> was adopted for more effective protection of family members from violence and harmonization of norms with EU regulations. More detailed solutions are provided for the prevention, sanctioning and suppression of domestic violence, the application of measures for the perpetrator, alleviating the consequences of violence by providing protection and assistance to victims of violence. The term family is more widely understood and includes spouses, children of each of them, and common children. Violence in the family is also understood in the same way, including economic violence. The law provides for cooperation and networking between competent social welfare services, health facilities, professional services and bodies for the needs of victims.

#### 4.2. Republic of Serbia

- a) Art.194. Criminal Code of the Republic of Serbia<sup>51</sup> criminalizes domestic violence, which has a basic form and three qualified forms. Whoever threatens the serenity, the integrity of the body, or the mental state of a member of his family by applying violence, by threatening to attack life or body, with drunk or negligent behavior will be sentenced to three months to three years in prison. The first qualified form refers to violence involving weapons, dangerous tools or other means that can cause serious injury or severe mental distress. The law prescribes a prison sentence of six months to five years. The second qualified form refers to the case when a criminal offense has resulted in serious bodily injury or severe health impairment or is only a criminal offense committed against an underage person. The law prescribes a prison sentence of two to ten years. The third qualified form refers to the case of the death of a family member by a criminal offense. The law prescribes a prison sentence of three to fifteen years.
- b) Subsidiary Criminal Legislation encompasses several regulations to combat domestic violence. The Code of Criminal Procedure (CPC)<sup>52</sup> establishes a prosecution-police investigation as a new model of investigation, provides for the leadership role of the state prosecutor and introduces general and special evidence for the prosecution of criminal offenses and perpetrators. The law on juvenile perpetrators of criminal offenses and the criminal-legal protection of juveniles<sup>53</sup> is of importance in this delicate matter.

---

<sup>47</sup> Anti-Discrimination Act RC, OG no 85/08

<sup>48</sup> Ombudsman Act for Children RC, OG no 96/03, 125/11, 20/12

<sup>49</sup> Deset godina pravobraniteljstva za djecu u Republici Hrvatskoj – Postignuća i izazovi, Pravobranitelj za djecu, Zagreb, 2013, p.15, 18-19.

<sup>50</sup> Op.cit. in note 32.

<sup>51</sup> Criminal Code RS, OG no 85/05, 88/05, 107/05, 72/09, 111/09, 121/12, 104/13, 108/14, 94/16

<sup>52</sup> Code of Criminal Procedure RS, OG no 72/11, 101/11, 121/12, 32/13, 45/13, 55/14

<sup>53</sup> Law on juvenile perpetrators of criminal offenses and the criminal-legal protection of juveniles RS, OG no 85/05

Especially important by-laws are General Protocol on the Treatment and Cooperation of Institutions, Bodies and Organizations in Situations of Violence Against Women in Family and Partnerships<sup>54</sup> and National Strategy for the Prevention and Suppression of Violence Against Women in Family and Partnership Relationships.<sup>55</sup>

- c) In addition to the criminal legislation combating domestic violence and other regulations. In the first place, this is the Constitution of the Republic of Serbia as a *lex generalis* and several *lex specialis* in the area of family law, gender equality, prohibition of discrimination and special protection of children. Constitution of the Republic of Serbia affirms universal principles and guarantees all citizens equal protection of rights, the rule of law (art.3), gender equality (art.15), human rights (minority rights) and civil liberties (art.18-81). It proclaims the prohibition of discrimination based on race, gender, national affiliation, social origin, birth, religion, political or other beliefs, property status, culture, language, age and disability (art.21).<sup>56</sup> Of great importance are the inviolability of physical and mental integrity (art.25), protection of persons and the suppression of violence against women and children in the family. Family law<sup>57</sup> prohibits family violence, entitles family members to protection from violence (art. 10) and provides for family-legal protection measures (art.197-200).<sup>58</sup> Domestic violence is defined as a behavior by which a family member endangers the integrity, mental health or serenity of another family member. The acts of domestic violence are considered causing or attempting bodily injury; provoking fear by threatening with murder or causing bodily injury to a family member or a close relative; coercion to sexual intercourse; instigating sexual intercourse or sexual intercourse with a person who has not yet turned 14 or with a helpless person; limiting the freedom of movement or communication with third parties; insults and any other presumptuous, reckless and malicious behavior. As a family members are considered: spouses or former spouses; children, parents and other blood relatives of that person in a tadalaxy or adoptable kinship, foster-related persons; persons who live or lived in the same family household; co-partners or former co-partners; persons who were or are still in emotional or sexual contact with each other, who have a common child or child on the road to be born although they have never lived in the same family household.<sup>59</sup> As measures to protect family members against the member who commits violence issued are the order for eviction from the family apartment or a house and an order to move to a family flat or house regardless of the ownership or lease of real estate; prohibition of approaching a family member at a certain distance; prohibition of access to premises around the place of residence or place of work of a family member; ban on further disturbance of a family member.<sup>60</sup> Law on Prohibition of Discrimination<sup>61</sup> provides for protection against discrimination on grounds of gender, race, ethnicity, color, language, religion, political or other belief, national or social origin, property status, union membership, education, social status, marital or family status, age, health status, disability, genetic heritage, gender identity, expression or sexual orientation. Gender Equality Law prohibits discrimination on the basis of gender, marital or family status and sexual orientation in terms of employment, labor and education. Special measures and support programs are also provided for victims of domestic violence, ocial and legal

---

<sup>54</sup> More: Multisektorska saradnja – institucionalni odgovor na nasilje nad ženama, available at: <http://sigurnakuca.net/upload/documents/SRBfinal.pdf>, (15.11.2018).

<sup>55</sup> National Strategy for the Prevention and Suppression of Violence Against Women in Family and Partnership Relationships, OG no 27/11, 20.04.2011.

<sup>56</sup> Constitution of the Republic of Serbia, OG no 98/06

<sup>57</sup> Family law RS, OG no 18/05, 72/11, 06/15

<sup>58</sup> More: Nikač Ž, *Koncept policije u zajednici i početna uskustva u Republici Srbiji*, KPA, Belgrade, 2012.

<sup>59</sup> Art.197. Op.cit. in note 51.

<sup>60</sup> Art.198. *Ibid.*

<sup>61</sup> Law on Prohibition of Discrimination RS, OG no 22/09.

assistance, compensation, elimination of consequences of violence, care for victims of violence (safe houses) and the prevention of further violence.<sup>62</sup> Law on Prevention of Domestic Violence<sup>63</sup> is *lex specialis* regulation adopted in the function of combating family violence, comprising of a set of measures to detect whether there is a risk of immediate domestic violence, and which are to be applied when the danger is discovered. Immediate danger of violence exists when the behavior of a potential perpetrator and other circumstances show a willingness to commit or repeat violence. Domestic Violence is an act of physical, sexual, psychological or economic violence by a perpetrator towards a person with whom they are currently married or have been married, a spouse or a partner or a person with whom they are directly related in first degree, indirectly related to the second degree or whom they are adopting, who is an adoptee, for whom they are a bread winner or who is a foster child or to the other person with whom they live or have lived in a common household. The law also applies to criminal proceedings for a number of criminal offenses by the Criminal Code.<sup>64</sup> The most important entities for the prevention of domestic violence, the provision of protection and support to victims are the police,<sup>65</sup> public prosecutor's office, courts and centers for social work. The role of institutions for child and social protection, education, education and health, gender equality bodies, local self-government bodies and associations is also significant. Police has the leading operational role to act on the basis of a report by the victim (injured party) and the recognition of domestic violence. Emergency measures are imposed by the police for a duration of 48 hours from the delivery of court orders and they can be further extended to 30 days.<sup>66</sup>

## 5. RESEARCH OF COMMITTED TYPES OF VIOLENCE AGAINST WOMEN IN THE AREA OF CROATIA AND SERBIA

The study included 30 women from Croatia and 30 women from Serbia who were victims of domestic violence. Table 2 shows the results of the research on the forms of violence committed against women in Croatia, while Table 3 shows the same data for Serbia.

<b>FORMS OF VIOLENCE AGAINST WOMEN - CROATIA</b>	
<b>Verbal violence</b> - insults, humiliations, accusations	<b>87%</b>
<b>Demonstration of force</b> - threats, throwing and breaking things and objects	<b>82%</b>
<b>Physical violence</b> - causing bodily injury	<b>75%</b>
<b>Sexual violence</b> – sexual coercion	38%
<b>Financial violence</b> - confiscation of money, joint things and property	68%
<b>Social violence</b> - limitation of freedom of movement	65%
<b>Emotional violence</b> - threats of taking one's own life and the family's life	64%
<b>Intellectual Violence</b> - prohibition of education and training, expression of religious traditions	45%
<b>Disabling the realization of the parenting role</b> - ban on contact and manipulation with children	50%
<b>Other forms</b> of violence	9%

*Table 2: Forms of violence against women in Croatia*

<sup>62</sup> Art.29. Gender Equality Law RS, OG no104/09

<sup>63</sup> Law on Prevention of Domestic Violence RS, OG no 94/16

<sup>64</sup> Božić V, Nikač Ž, *Kaznenopravni aspekti suzbijanja nasilja u obitelji u svjetlu novih zakonskih rešenja*, Zbornik - krivično zakonodavstvo između prakse i propisa i usklađivanje sa evropskim standardima, Srpsko udruženje za krivičnopravnu teoriju i praksu i Ministarstvo pravde RS, Milići 2017, p.277-293.

<sup>65</sup> Gačević G, Nikač Ž, *Akciono planiranje policije u okviru prevencije nasilja*, Projekt „Nasilje u Srbiji, Zbornik radova 2, KPA, Belgrade 2015, p.75-92.

<sup>66</sup> *Ibid*, art.17.

<b>FORMS OF VIOLENCE AGAINST WOMEN - SERBIA</b>	
<b>Verbal violence</b> - insults, humiliations, accusations	<b>89%</b>
<b>Demonstration of force</b> - threats, throwing and breaking things and objects	<b>88%</b>
<b>Physical violence</b> - causing bodily injury	<b>80%</b>
<b>Sexual violence</b> – sexual coercion	45%
<b>Financial violence</b> - confiscation of money, joint things and property	70%
<b>Social violence</b> - limitation of freedom of movement	68%
<b>Emotional violence</b> - threats of taking one's own life and the family's life	61%
<b>Intellectual Violence</b> - prohibition of education and training, expression of religious traditions	41%
<b>Disabling the realization of the parenting role</b> - ban on contact and manipulation with children	55%
<b>Other forms</b> of violence	12%

*Table 3: Forms of violence against women in Serbia*

Overall, for Croatia and Serbia, regarding the education and age of respondents, these are women of different ages and different degrees of education, which has contributed to the quality of research. Thus, women who participated in the study were between the ages of 20 and 65 years, with most of them between 35 and 50 years (over 60%). It should also be noted that most of the respondents were of secondary education (about 60%), while the least of them were uneducated women. About 55% of women were employed, while 40% were unemployed or with minimal monthly earnings. Only 5% of women realized above average monthly income. The majority of women were exposed to verbal violence, which is an initial stage when rating violence against women. Next, there is a manifestation of force against women leading to physical violence. These three categorizations of violence are the most common and predominate in almost 80-90% of cases. Financial, emotional, and social violence are the second most pronounced violence against women and account for around 60-70% of the total violence. Disabling the realization of parental role and intellectual violence in the total percentage of 45-50% is in the third place in the share of violence against women. Sexual violence is only in the fourth place of all violence against women, which is perhaps an unexpected result of analyzed forms of violence against women. From the research carried out, it is concluded that violence against women is present in different socioeconomic levels of society, but there is a fairly large number of women exposed to domestic violence that are unemployed or have extremely low incomes.

## **6. CONCLUSION**

The phenomenon of domestic violence has long been regarded as a personal and family matter only because the man had a dominant position in the society. Women and children were unequal and without the possibility of deciding on matters of personal and family nature. With industrialization and democratization there are changes in society and domestic violence is no longer seen as a private matter, but as a public and social problem that requires a state reaction and the protection of victims of domestic violence, especially women and children. Under the auspices of the UN and CoE international documents have been adopted, which are today a legal basis for combating family violence, prosecuting perpetrators and protecting victims of violence.

Among them are CEDAW, UN Convention on the Rights of the Child and Istanbul Convention, with the view that domestic violence is one of the most difficult social problems that requires a harmonized response by the international community. Croatia and Serbia have harmonized national legislation with international documents and have novelized criminal legislation. As a member of EU, Croatia has foreseen measures, mechanisms, bodies and organs to combat domestic violence and the protection of victims. As a candidate country for EU accession, Serbia has, after the opening of Chapters 23 and 24 (right, internal affairs and security) in the phase of harmonization of legal norms and acceptance of good EU practice. A significant step forward by Croatia and Serbia has been made by adopting special laws on combating domestic violence that are in line with EU regulations and court-based solutions. The conducted research on certain types of domestic violence against women in Croatia and Serbia points to the seriousness of this problem within which the most frequent forms are verbal violence, demonstration of force and physical violence. Social reaction to increased domestic violence does not only include measures of criminal prosecution, but must include awareness raising among citizens and solidarity of the community, assistance and support to victims of violence.

**ACKNOWLEDGEMENT:** *This research has been fully supported by the Croatian Science Foundation, under the project no 1949 Multidisciplinary Research Cluster on Crime in Transition-Trafficking in Human Beings, Corruption and Economic Crime and project no 179045 Development of institutional capacity, standards and procedures for countering organized crime and terrorism in the conditions of international integration, Ministry of Education and Science, RS.*

#### **LITERATURE:**

1. Ajdukovic M, *Određenje i oblici nasilja u obitelji*, Društvo za psihološku pomoć, Zagreb, 2000
2. Ajduković M, *Obilježja žrtvi i počinitelja obiteljskog nasilja*, Društvo za psihološku pomoć, Zagreb, 2000
3. Ajduković M, Mamula M, Pečnik N, Tolle N, *Nasilje u partnerskim odnosima*, Društvo za psihološku pomoć, Zagreb, 2000
4. Anti-Discrimination Act RC, OG no 85/08
5. Bilić V, Buljan-Flander G, Hrpka H, *Nasilje nad djecom i među djecom*, Naklada Slap, Jastrebarsko, 2000
6. Božić V, *Suzbijanje organiziranog kriminaliteta u svjetlu pozitivnog kaznenog zakonodavstva Republike Hrvatske*, Zbornik radova „Suzbijanje organiziranog kriminala kao preduslov vladavine prava“, Institut za uporedno pravo, Vršac, 2016, p. 285-300.
7. Božić V, Nikač Ž, *Kaznenopravni aspekti suzbijanja nasilja u obitelji u svjetlu novih zakonskih rešenja*, Zbornik - krivično zakonodavstvo između prakse i propisa i usklašivanje sa evropskim standardima, Srpsko udruženje za krivičnopravnu teoriju i praksu i Ministarstvo pravde RS, Milići 2017, p.277-293.
8. Buljan-Flander G, Kocijan-Hercigonja D, *Zlostavljanje i zanemarivanje djece*, Marko M. usluge d.o.o., Zagreb, 2003
9. Calvete E, Orue I, *Cognitive Mechanisms of the Transmission of Violence: Exploring Gender Differences among Adolescents Exposed to Family Violence*, Journal of Family Violence, 28(1), Springer, USA, North Carolina, 2013
10. CEDAW, ratified OG SFRJ – IA, no 11/81
11. Constitution of the Republic of Croatia, OG no 85/10, 05/14
12. Constitution of the Republic of Serbia, OG no 98/06
13. Council of Europe Convention on preventing and combating violence against women and domestic violence, CETS No. 210

14. Criminal Code RC, OG no 125/11, 144/12, 61/15, 101/17
15. Criminal Code RS, OG no 85/05, 88/05, 107/05, 72/09, 111/09, 121/12, 104/13, 108/14, 94/16
16. Criminal Procedure Act RC, OG no 110/97, 112/99, 58/02, 62/03, 115/06, 152/08, 76/09
17. Code of Criminal Procedure RS, OG no 72/11, 101/11, 121/12, 32/13, 45/13, 55/14
18. Family law RC, OG no 110/97, 27/98, 50/00, 129/00, 51/01, 111/03, 190/03, 105/04, 84/05, 71/06, 110/07, 152/08
19. Family law RS, OG no 18/05, 72/11, 06/15
20. Gačević G, Nikač Ž, Akciono planiranje policije u okviru prevencije nasilja, Projekt „Nasilje u Srbiji, Zbornik radova 2, KPA, Belgrade 2015, p.75-92.
21. Gender Equality Act RC, OG no 82/08
22. Gender Equality Law RS, OG no 104/09
23. Grozdanić V, Škorić M, Vinja I: *Nasilje u obitelji u svjetlu promjena Kaznenog zakona*, HLJKPP, Zagreb, vol. 17, no 2/2010
24. Group of authors, *Nasilje nad ženama - prepreka razvoju*, International documents, Autonomni ženski centar, Belgrade, 2005, available at:  
<http://www.womenngo.org.rs/publikacije-dp/medjunarodni%20dokumenti.pdf>
25. Juvenile Court Act RC, OG no 111/97, 27/98, 12/02
26. Kolesarić J, Kolesarić D, Hečimović I, Paripović S, *I will – I know – I can*, Prirucnik, Virovitica, 2014
27. Law on Protection from Domestic Violence RC, OG no 137/09, 14/10, 60/10
28. Law on the Elimination of Domestic Violence, OG no 94/16
29. Law on Compensation for Victims of Crime RC, OG no 80/08
30. Law on Police Affairs and Authorities RC, OG no 76/09
31. Law on juvenile perpetrators of criminal offenses and the criminal-legal protection of juveniles RS, OG no 85/05
32. Law on Prohibition of Discrimination RS, OG no 22/09
33. Law on Prevention of Domestic Violence RS, OG no 94/16
34. Multisektorska saradnja – institucionalni odgovor na nasilje nad ženama, available at:  
<http://sigurnakuca.net/upload/documents/SRBfinal.pdf>
35. National Strategy for the Prevention and Suppression of Violence Against Women in Family and Partnership Relationships, RS OG no 27/11, 20.04.2011.
36. Nikač Ž, *Koncept policije u zajednici i početna uskustva u Republici Srbiji*, KPA, Belgrade, 2012
37. Ombudsman Act for Children RC, OG no 96/03, 125/11, 20/12
38. Optional Protocol to the Convention on the Elimination of All Forms of Discrimination against Women, 22.12.1999., available at:  
[http://www.un.org.yu/pdf\\_int\\_konv/int\\_hr\\_conv/CEDAW Optional Protocol-Serbian.pdf](http://www.un.org.yu/pdf_int_konv/int_hr_conv/CEDAW Optional Protocol-Serbian.pdf)
39. Pravobranitelj za djecu, *Deset godina pravobraniteljstva za djecu u Republici Hrvatskoj – Postignuća i izazovi*, Zagreb, 2013
40. Pećnik N, *Međugeneracijski prijenos zlostavljanja djece*, 2 izd. Naklada Slap, Jastrebarsko, 2005
41. Protocol on the Treatment of Domestic Violence, available at:  
<http://www.mspm.hr/UserDocsImages/djeca%20i%20obitelj/Protokol-o-postupanju-u-slucaju-nasilja-u-obitelji.pdf>
42. Radić I, Radina A, *Zaštita od nasilja u obitelji: obiteljskopравни, prekršajnopравни i kazneno pravni aspekt*, Pravni fakultet Split, Zbornik radova, 3/2014
43. Rajter M, *Obiteljski stresori i obilježja obitelji kao prediktori roditeljskog nasilja nad djecom*, doktorski rad, Pravni fakultet Sveučilišta u Zagrebu, Zagreb, 2013
44. Van Bueren G, *Child rights in Europe*, Council of Europe, December 2007



45. UN Convention on the Elimination of All Forms of Discrimination Against Women – CEDAW, available at: <http://www.un.org/womenwatch/daw/cedaw/text/econvention.htm>
46. UN Convention on the Rights of the Child, adopted 20 th November 1989, OG SFRJ no 15/90, OG RC-IA no 12/93, 20/97
47. Zloković J, *Nasilje nad roditeljima – Obiteljska tajna?*, Grafika Zambelli, Rijeka, 2009
48. Witness Protection Act RC, OG no 163/03

## EXAMINING THE EFFECTS OF TRAVEL CONSTRAINTS, TOURIST SATISFACTION AND WEBSITE IMAGE ON TOURIST LOYALTY IN DEVELOPING COUNTRIES CONTEXT

**Samar Rahi**

*Research Scholar at Marketing & Technology Management Universiti Sultan Zainal Abidin (UniSZA), Terengganu, Malaysia  
sr\_adroit@yahoo.com*

### **ABSTRACT**

*This study aimed to investigate the underlying dimensions of travel constraints tourist satisfaction and destinations website image on behavioral and attitudinal intentions of travelers. This study contributes to the body of knowledge that how tourist organization can retain their customers by studying antecedents of travel constraints, satisfaction and web image. In addition to that, this study extends the previous research by examining the role of travel constraint, satisfaction and web image within emerging economies like Pakistan. Deductive approach and positivism paradigm is used for research design. Data is collected through questionnaires from those customers who have travelled recently on selected destinations. For sampling, simple random sampling technique is used. A pilot study is conducted with 100 respondents. Structural equation modeling was used to examine the hypothesized relationship. This study is unique in its nature as it examines the dimensions of travel constraints and destination image in South Asian context.*

**Keywords:** *Travel Constraints, Destination image on the website, Satisfaction, Attitudinal and behavioral intentions of loyalty, Pakistan*

### **1. INTRODUCTION**

Tourism has a significant role for the economic development of any country. San Martín and Del Bosque (2008) illustrate that tourism provide income and jobs and has significant impact on related industries. Investigating the theories of customer loyalty in marketing literature tourist loyalty in the field of tourism has been studied since 1990s (Dimanche & Havitz, 1995). Travelling experience considers as a product and tourist loyalty reflects their attitudinal and behavioral intentions. In other words we can imply that loyalty motivate travelers to revisit or to recommend destination to friends and family (Oppermann, 2000). In marketing literature tourism studies have been conducted on tourist loyalty, satisfaction, service quality, value and destination image (Chen & Chen, 2010; Huang & Hsu, 2009; Mechinda, Serirat, & Gulid, 2009; Ramkissoon, Uysal, & Brown, 2011; Yoon & Uysal, 2005). Therefore, much less research work has been done on travel constraints. Before the concept of negotiation, travel constraint was known as barrier (Hubbard & Mannell, 2001; Nyaupane & Andereck, 2007). Gilbert and Hudson (2000) define that for managers it is important to observe the traveler needs and make an analysis that why they don't travel, it will help them to make new strategies. In prior studies travel constraints have been found in western context that usually focus on social and psychological characteristics of travelers. However, these studies have ignored the individual needs, experiences, cultural and political dimensions (Dong & Chick, 2012). The current study examines the leisure constraints model (LCM) that have been used in different travel studies and known as most influential theoretical framework (Crawford, Jackson, & Godbey, 1991). Several studies have been conducted on satisfaction with relation to revisit intention. Satisfaction is seen tourists experience where tourist prefer to revisit the same destination over and again (Alexandros & Jaffry, 2005; Bigné, Andreu, & Gnoth, 2005; Bowen, 2001; Kozak & Rimmington, 2000; Oh, 1999). Bigne, Sanchez, and Sanchez (2001) research work explores satisfaction with relation to destination image and perceived quality.

This study will broaden our understanding that how service provider companies especially tourist organization can retain their customers by studying travel constraints, satisfaction and website image. In emerging markets like South Korea, China and India traveler are facing several types of traveling constraints which includes intrapersonal, interpersonal and structural constraints. According to Lai, Li, and Harrill (2013), intrapersonal and structural constraints were main constraint for Chinese outbound travelers. To get deeper insight of these issues this research investigates the effects of travel constraints with relation to satisfaction and website image on tourist loyalty.

## **2. LITERATURE REVIEW**

### **2.1. Travel Constraints**

In marketing literature there are three types of travel constraints. Primarily, intrapersonal constraints this type illustrates individual attributes and psychological position for instance one's self interest, depression, anxiety, and religiosity concerns (Crawford et al., 1991; Fredman & Heberlein, 2005; Nyaupane & Andereck, 2007). Intrapersonal constraint in travel is the most influential type of constraints (Carroll & Alexandris, 1997; Iso-Ahola, Mannell, & Wade, 1985). At second stage, interpersonal constraints that comes with social interaction or individual characteristics. For example one's can feel discomfort when they would be without their travel partners or loved ones (Crawford et al., 1991; Fredman & Heberlein, 2005; Hudson & Gilbert, 2000). The third and last stage of travel constraint is the structural constraints. It comes when leisure preference are planned but before leisure participation. Literature suggests that structural constraints may intrude between travel preference and participation. For instance, lack of information, time and money (Crawford et al., 1991; Hudson & Gilbert, 2000; Nyaupane & Andereck, 2008).

### **2.2. Destination image on the website**

Destination is known as any Town, City or recreational place and image is the mental perception about destination. This is the era of information and technology, where tourists have access of numerous information sources to organize their trip and internet is one of them. Internet is the most credible tool and source of information. It plays an important role in tourist decision making, moreover it is a strong communication channel now a days (Rahi Samar & Mazuri, 2019b). Internet provides you direct access to destinations websites all around the globe. It remove all boundaries and provide efficient information to tourists where they can imagine about their desired destination and can take decision to travel (Choi, Lehto, & O'Leary, 2007). Foremost, holiday makers get information from destination websites. Beldona and Cai (2006) defines that a website is the most attractive and useful tool to present intangible tourism product, in addition to that website is the source of accurate attractive and accessible information. Internet helps tourist to mitigate the risk of making a wrong choice, it gives a virtual image before travel to selected destination, meanwhile it plays a vital role in travel and tourism services (Yusta, Monge, & Vega, 2008). What influence to traveler is the information of destination on website in the shape of web contents, it gives a chance to traveler to perceive and create a virtual image in their minds (Doolin, Burgess, & Cooper, 2002). For the credibility of the website it is necessary that destination website must be well in design for instance graphics, layout, physical appearance, color in addition to that, web interface and ease of use are also important in a destination website it includes reliability, efficiency, functionality and usability all are important (Loda, Teichmann, & Zins, 2009; Rahi, Ghani, & Ngah, 2019; Rahi Samar & Mazuri, 2019a). Website is the unique tool to attract your potential customer, it provides latest information to traveler about destination furthermore web related technology can also enhance the traveler information level (Lu, Lu, & Zhang, 2002; Rahi, 2018b; R Samar, 2018). De Farias, Salomao, Kovacs, and Melo (2013) illustrate that, functional approach may not be better,

however by using balance approach that includes pictures and contents may play an important role to enhance the destination image. In this era of technology where people spend most of their time on internet, website is an important factor in destination image. Researcher will try to find the best approach for destinations website that will be helpful for traveler as well as for tourist managers to enhance the intellectual image of destination.

### **2.3. Tourist Loyalty**

Loyalty has been described in different ways. Customer retention has become an important factor in organization because to gain a new customer is far expensive than to retain (F Alnaser, Ghani, & Rahi, 2018; Rosenberg & Czepiel, 1984). In marketing literature the first stage of loyalty is attitudinal loyalty, it motivate customers to purchase or intention to repurchase. Customer beliefs, Perceived value and overall attitude are the key component that provoke customers to repurchase a product or services (Fournier, 1994; Hawkins, Best, & Coney, 1989; Rahi, Ghani, & Muhamad, 2017). Intention to revisit is the most favorable factor for travel products and destinations and perceived as a desirable segment in travel industry (FMI Alnaser, Ghani, & Rahi, 2017; Lau & McKercher, 2004). Intention to revisit is also important because it is cost-effective, it takes less marketing cost usually travelers takes during their first time visit Shoemaker and Lewis (1999). The second stage is behavioral loyalty, It is important and includes word of mouth (WOM) or the act of recommendation to others, it also includes patronage rewards (Hughes, 1991; Rahi, Ghani, & Alnaser, 2017; Sönmez & Graefe, 1998). Tourist who have affiliation with destination usually spend extra time at a destination in addition to that they spread positive word of mouth that is unique for destination image and overall loyalty (F. M. I. Alnaser, M. A. Ghani, S. Rahi, M. Mansour, & H. Abed, 2017; Oppermann, 1998, 2000; Shoemaker & Lewis, 1999), moreover they actively participate in consumptive activities Lehto, O'Leary, and Morrison (2004). At functional level, both dimensions attitudinal (intention to revisit) and Behavioral (Recommend to others) have been used in literature to explore the consequences of tourist loyalty (Alcañiz, García, & Blas, 2009; F. Alnaser, M. Ghani, S. Rahi, M. Mansour, & H. Abed, 2017; Horng, Liu, Chou, & Tsai, 2012; Hung & Petrick, 2012; Oppermann, 2000).

### **2.4. Tourist Satisfaction**

Satisfaction is a process where tourist share their emotional feeling after experiencing the place Baker and Crompton (2000). Fornell (1992) defines that measuring satisfaction can help holiday makers to improve their services. Satisfaction is important to compare performance of organization and destinations Kotler (1994). Some other researchers work have proved that satisfaction is the best toll to evaluate travel related products and services (Bramwell, 1998; Noe & Uysal, 1997; Ross & Iso-Ahola, 1991; Schofield, 2000). Some important model have been studied to link the satisfaction with travel literature including expectation/disconfirmation paradigm by (Oliver, 1980); equity theory (Oliver & Swan, 1989) ; norm models (LaTour & Peat, 1979); and perceived overall performance (Tse & Wilton, 1988). Oliver (1980) Expectation/disconfirmation paradigm defines that consumer expectation before purchase and after purchase consumer compare actual performance to their expectation. Meanwhile, Oliver and Swan (1989) equity theory, it defines that satisfaction comes once a consumer get benefits that what they have spent in the shape of price, effort and time. LaTour and Peat (1979) norm theory defines comparison of purchased product with other products for instance comparison of current destination with previous destination.

### **2.5. Theoretical Framework**

A theoretical framework is developed that shows how different dimensions of travel constraints, satisfaction, and website image impact on customer loyalty.

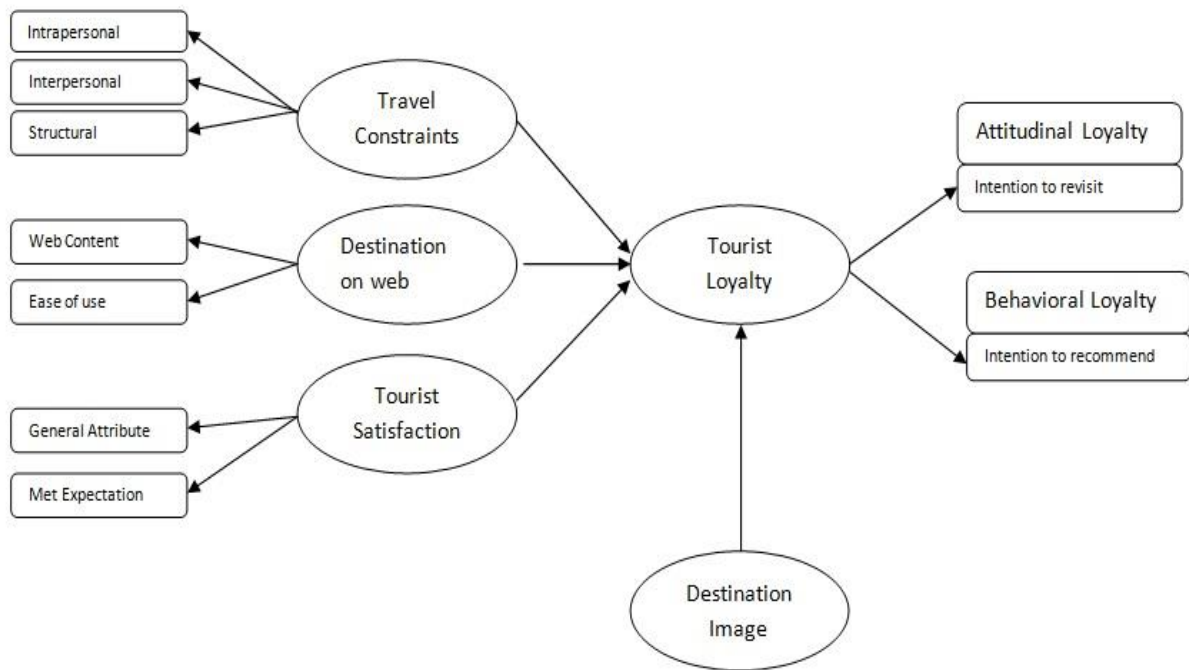

Figure 1: Theoretical Framework

### 3. RESEARCH METHODOLOGY

#### 3.1. Research philosophy

Positive Paradigm is used to verify the research model. For this, author needs to apply statistical methods by using quantitative techniques (S. Rahi, 2017). This approach is also known as deductive approach (Rahi, 2018a). The main reason for using this approach is the existence of the theory (S Rahi, 2017). In marketing literature related to travel and tourism several studies have been conducted to explore the role of tourist loyalty on motivation, satisfaction, service quality, value and destination image (Chen & Chen, 2010; Huang & Hsu, 2009; Mechinda et al., 2009; Ramkissoon et al., 2011; Yoon & Uysal, 2005). Website is the unique tool to attract your potential customer, it provides latest information to traveler about destination furthermore web related technology can also enhance the traveler information level (Lu et al., 2002; Rahi & Ghani, 2018a, 2018b; Rahi Samar, Norjaya, & Feras, 2017). De Farias et al. (2013) illustrate that, functional approach may not be better, however by using balance approach that includes pictures and contents may play an important role to enhance the destination image. Fornell (1992) defines that measuring satisfaction can help holiday makers to improve their services. Satisfaction is important to compare performance of organization and destinations (Ghani, Rahi, Yasin, & Alnaser, 2017; Kotler, 1994).

#### 3.2. Ontology & epistemology

Ontology deals with the nature of reality about the concept of knowledge whereas Epistemology deals with the connection between the researcher and the subject or the topic that is going to be researched by remaining objective or subjective in external environment (F. M. Alnaser et al., 2018; Creswell & Clark, 2007; Rahi, 2015). As the positivist paradigm of research seems the most relevant paradigm for this research because researcher aims to collect the data being objective, so particularly these two concepts that is Ontology and Epistemology are also studied in this paradigm.

### **3.3. Deductive approach**

According to Collis et al. (2003) deductive research is “a study in which a conceptual and theoretical structure is developed which is then tested by empirical observation; thus particular instances are deducted from general influences.” In this research, researcher intends to test a theory by collecting fresh data from respondents and observe the findings by applying various statistical tests and in line with (Rahi & Abd. Ghani, 2018a). This method is generally recommended for specific studies in which researcher work on particular concept by creating assumptions and then verifying those assumptions (Collis et al., 2003; Rahi & Abd. Ghani, 2018b). In this study researcher is assuming that there is a significant relationship between travel constraints Tourist satisfaction website image on tourist loyalty so, deductive approach is more suitable to be taken into account.

### **3.4. The Positivist Paradigm**

The supporters of this paradigm believe that true knowledge can be obtained through observation and experiment (Guba & Lincoln, 1994) So positivists normally select scientific method to produce knowledge. Positivism is also called Scientific Method, Empirical Science, Post Positivism and Quantitative Research (Guba & Lincoln, 1994; Rahi, 2016b; S. Rahi & M. A. Ghani, 2016). Levine, Sober, and Wright (1987) discussed that in positivism reality remains stable and can be observed and can be described through an objective. A strong debate is available on the issue of using positivist paradigm that whether it is appropriate for social sciences or not (Hirschheim, 1985; Rahi, 2016a; S. Rahi & M. Ghani, 2016). So in this study of Customer loyalty with relation to travel constraints in Tourist sector, researcher aims to test prior assumptions so positivist paradigm is good to follow in this study.

### **3.5. Quantitative Method**

Quantitative method is a scientific method and its grounds can be identified in positivism. Grinnell Jr and Unrau (2010) demonstrated that this approach is mostly used by the Positivists. This method focuses on fresh data collection in accordance to the problem from large population and analysis of the data but ignore an individual’s emotions and feelings or environmental context (Collis et al., 2003; Rahi, Ghani, Alnaser, & Ngah, 2018; S. Samar, Ghani, & Alnaser, 2017). Similarly, Arkin (2009) discussed that the quantitative strategy works on objective and measure it through the actions and opinions which helps researcher to describe the data rather to interpret the data. This study will use the quantitative method because researcher has assumed that travel constraints has significant impact on customer loyalty and researchers aim is to test or verify a study, quantitative method is helpful and advised method.

### **3.6. Pilot Test**

Participants for the study were from Pakistan. The study is focused on the Pakistani travel sector because Wee et al. (1996) suggested that the service industry is more than the manufacturing industry. Adopting random sampling, we have asked to tourist to respond according to their travel experience.

### **3.7. Sample size**

The sample size selected for the research purpose constituted of 500 traversers though structured questionnaire . Data will be collected by selecting age group (20-25, 26-35, 46-55, 55 & above) and gender (male, female) as nominal scale.

### **3.8. Validity & Reliability**

To check the reliability of the instrument, Chronbach’s Alpha values were calculated with the help of software which are presented in the next section with detailed explanation and

interpretation. Data collection instrument was developed in which 15 statements were asked from the employees on 5-point Likert scale (from Strongly Disagree to Strongly Agree) and they were asked to rate the statements as per best of their knowledge and feelings.

### 3.9. Data Presentation

In this section, results drawn from the collected data is presented and appropriate interpretation is also given for the results of data which we received after appropriate analysis. Structural equation modeling was used to serve the purpose and to conduct the detailed analysis along with the tabular and graphical presentation of data and results and in line with Rahi, Ghani, and Ngah (2018). For descriptive type of questions, tables were made for each question and some of the questions were described graphically with the help of bar charts and histograms.

### LITERATURE:

1. Alcañiz, E. B., García, I. S., & Blas, S. S. (2009). The functional-psychological continuum in the cognitive image of a destination: A confirmatory analysis. *Tourism management*, 30(5), 715-723.
2. Alexandros, A., & Jaffry, S. (2005). Stated preferences for two Cretan heritage attractions. *Annals of Tourism Research*, 32(4), 985-1005.
3. Alnaser, F., Ghani, M., & Rahi, S. (2017). The Impact of SERVQUAL Model and Subjective Norms on Customer's Satisfaction and Customer Loyalty in Islamic Banks: A Cultural Context. *Int J Econ Manag Sci*, 6(5), 455.
4. Alnaser, F., Ghani, M., & Rahi, S. (2018). Service quality in Islamic banks: The role of PAKSERV model, customer satisfaction and customer loyalty. *Accounting*, 4(2), 63-72.
5. Alnaser, F., Ghani, M., Rahi, S., Mansour, M., & Abed, H. (2017). Determinants of Customer Loyalty: The Role of Service Quality, Customer Satisfaction and Bank Image of Islamic Banks in Palestine. *Int J Econ Manag Sci*, 6(461), 2.
6. Alnaser, F. M., Ghani, M. A., Rahi, S., Mansour, M., Abed, H., & Alharbi, A. H. (2018). *EXTENDING THE ROLE OF SERVQUAL MODEL IN ISLAMIC BANKS WITH SUBJECTIVE NORMS, CUSTOMER SATISFACTION AND CUSTOMER LOYALTY*. Paper presented at the Economic and Social Development (Book of Proceedings), 32nd International Scientific Conference on Economic and Social.
7. Alnaser, F. M. I., Ghani, M. A., Rahi, S., Mansour, M., & Abed, H. (2017). The Influence of Services Marketing Mix (7 Ps.) and Subjective Norms on Customer's Satisfaction in Islamic Banks of Palestine. *European Journal of Business and Management*, 9(27).
8. Baker, D. A., & Crompton, J. L. (2000). Quality, satisfaction and behavioral intentions. *Annals of Tourism Research*, 27(3), 785-804.
9. Beldona, S., & Cai, L. A. (2006). *An exploratory evaluation of rural tourism websites*. Paper presented at the Journal of Convention & Event Tourism.
10. Bigné, J. E., Andreu, L., & Gnoth, J. (2005). The theme park experience: An analysis of pleasure, arousal and satisfaction. *Tourism management*, 26(6), 833-844.
11. Bigne, J. E., Sanchez, M. I., & Sanchez, J. (2001). Tourism image, evaluation variables and after purchase behaviour: inter-relationship. *Tourism management*, 22(6), 607-616.
12. Bowen, D. (2001). Antecedents of consumer satisfaction and dis-satisfaction (CS/D) on long-haul inclusive tours—a reality check on theoretical considerations. *Tourism management*, 22(1), 49-61.
13. Bramwell, B. (1998). User satisfaction and product development in urban tourism. *Tourism management*, 19(1), 35-47.
14. Carroll, B., & Alexandris, K. (1997). Perception of constraints in strength of motivation: Their relationship to recreational sport participation in Greece. *Journal of Leisure Research*, 29(3), 279.

15. Chen, C.-F., & Chen, F.-S. (2010). Experience quality, perceived value, satisfaction and behavioral intentions for heritage tourists. *Tourism management*, 31(1), 29-35.
16. Choi, S., Lehto, X. Y., & O'Leary, J. T. (2007). What does the consumer want from a DMO website? A study of US and Canadian tourists' perspectives. *International Journal of Tourism Research*, 9(2), 59-72.
17. Collis, J., Hussey, R., Crowther, D., Lancaster, G., Saunders, M., Lewis, P., . . . Gill, J. (2003). *Business research methods*: Palgrave Macmillan, New York.
18. Crawford, D. W., Jackson, E. L., & Godbey, G. (1991). A hierarchical model of leisure constraints. *Leisure sciences*, 13(4), 309-320.
19. Creswell, J. W., & Clark, V. L. P. (2007). *Designing and conducting mixed methods research*: Wiley Online Library.
20. De Farias, A., Salomao, E. A. C., Kovacs, M. H., & Melo, S. (2013). Destination image on the web: evaluation of pernambuco's official tourism destination websites. *Business Management Dynamics*, 2(10), 35\_\_48.
21. Dimanche, F., & Havitz, M. E. (1995). Consumer behavior and tourism: Review and extension of four study areas. *Journal of Travel & Tourism Marketing*, 3(3), 37-57.
22. Dong, E., & Chick, G. (2012). Leisure constraints in six Chinese cities. *Leisure sciences*, 34(5), 417-435.
23. Doolin, B., Burgess, L., & Cooper, J. (2002). Evaluating the use of the Web for tourism marketing: a case study from New Zealand. *Tourism management*, 23(5), 557-561.
24. Fornell, C. (1992). A national customer satisfaction barometer: The Swedish experience. *the Journal of Marketing*, 6-21.
25. Fournier, S. (1994). A person-brand relationship framework for strategic brand management. *University of Florida, Gainesville, FL*.
26. Fredman, P., & Heberlein, T. A. (2005). Visits to the Swedish mountains: Constraints and motivations. *Scandinavian Journal of Hospitality and Tourism*, 5(3), 177-192.
27. Ghani, M. A., Rahi, S., Yasin, N. M., & Alnaser, F. M. (2017). Adoption of Internet Banking: Extending the Role of Technology Acceptance Model (TAM) with E-Customer Service and Customer Satisfaction. *World Applied Sciences Journal*, 35(9), 1918-1929.
28. Gilbert, D., & Hudson, S. (2000). Tourism demand constraints: A skiing participation. *Annals of Tourism Research*, 27(4), 906-925.
29. Grinnell Jr, R. M., & Unrau, Y. A. (2010). *Social work research and evaluation: Foundations of evidence-based practice*: Oxford University Press.
30. Guba, E. G., & Lincoln, Y. S. (1994). Competing paradigms in qualitative research. *Handbook of qualitative research*, 2, 163-194.
31. Hawkins, D. I., Best, R. J., & Coney, K. A. (1989). *Consumer Behavior: Implications for Marketing Strategy*, Homewood, IL: Richard D. Irwin: Inc.
32. Hirschheim, R. A. (1985). Information Systems Epistemology: An Historical Perspective. *Research methods in information systems*, 13-35.
33. Horng, J.-S., Liu, C.-H., Chou, H.-Y., & Tsai, C.-Y. (2012). Understanding the impact of culinary brand equity and destination familiarity on travel intentions. *Tourism management*, 33(4), 815-824.
34. Huang, S. S., & Hsu, C. H. (2009). Effects of travel motivation, past experience, perceived constraint, and attitude on revisit intention. *Journal of travel research*.
35. Hubbard, J., & Mannell, R. C. (2001). Testing competing models of the leisure constraint negotiation process in a corporate employee recreation setting. *Leisure sciences*, 23(3), 145-163.
36. Hudson, S., & Gilbert, D. (2000). Tourism constraints: The neglected dimension in consumer behaviour research. *Journal of Travel & Tourism Marketing*, 8(4), 69-78.



37. Hughes, K. (1991). Tourist satisfaction: A guided “cultural” tour in North Queensland. *Australian Psychologist*, 26(3), 166-171.
38. Hung, K., & Petrick, J. F. (2012). Testing the effects of congruity, travel constraints, and self-efficacy on travel intentions: An alternative decision-making model. *Tourism management*, 33(4), 855-867.
39. Iso-Ahola, S. E., Mannell, R. C., & Wade, M. (1985). Social and psychological constraints on leisure. *Constraints on leisure.*, 111-151.
40. Kotler, P. (1994). *Marketing management, analysis, planning, implementation, and control*, Philip Kotler.
41. Kozak, M., & Rimmington, M. (2000). Tourist satisfaction with Mallorca, Spain, as an off-season holiday destination. *Journal of travel research*, 38(3), 260-269.
42. Lai, C., Li, X. R., & Harrill, R. (2013). Chinese outbound tourists' perceived constraints to visiting the United States. *Tourism management*, 37, 136-146.
43. LaTour, S. A., & Peat, N. C. (1979). Conceptual and methodological issues in consumer satisfaction research. *Advances in consumer research*, 6(1).
44. Lau, A. L., & McKercher, B. (2004). Exploration versus acquisition: A comparison of first-time and repeat visitors. *Journal of travel research*, 42(3), 279-285.
45. Lehto, X. Y., O’Leary, J. T., & Morrison, A. M. (2004). The effect of prior experience on vacation behavior. *Annals of Tourism Research*, 31(4), 801-818.
46. Levine, A., Sober, E., & Wright, E. O. (1987). Marxism and methodological individualism. *New Left Review*, 162, 67-84.
47. Loda, M. D., Teichmann, K., & Zins, A. H. (2009). Destination websites' persuasiveness. *International journal of culture, tourism and hospitality research*, 3(1), 70-80.
48. Lu, Z., Lu, J., & Zhang, C. (2002). Website development and evaluation in the Chinese tourism industry. *Networks and Communication Studies*, 16(3-4), 191-208.
49. Mechinda, P., Serirat, S., & Gulid, N. (2009). An examination of tourists' attitudinal and behavioral loyalty: comparison between domestic and international tourists. *Journal of vacation marketing*, 15(2), 129-148.
50. Noe, F. P., & Uysal, M. (1997). Evaluation of outdoor recreational settings: A problem of measuring user satisfaction. *Journal of Retailing and Consumer Services*, 4(4), 223-230.
51. Nyaupane, G. P., & Andereck, K. L. (2007). Understanding travel constraints: Application and extension of a leisure constraints model. *Journal of travel research*.
52. Nyaupane, G. P., & Andereck, K. L. (2008). Understanding Travel Constraints: Application and Extension of a Leisure Constraints Model. *Journal of travel research*, 46(4), 433-439.
53. Oh, H. (1999). Service quality, customer satisfaction, and customer value: A holistic perspective. *International Journal of Hospitality Management*, 18(1), 67-82.
54. Oliver, R. L. (1980). A cognitive model of the antecedents and consequences of satisfaction decisions. *Journal of Marketing Research*, 460-469.
55. Oliver, R. L., & Swan, J. E. (1989). Equity and disconfirmation perceptions as influences on merchant and product satisfaction. *Journal of consumer research*, 16(3), 372-383.
56. Oppermann, M. (1998). Destination threshold potential and the law of repeat visitation. *Journal of travel research*, 37(2), 131-137.
57. Oppermann, M. (2000). Tourism destination loyalty. *Journal of travel research*, 39(1), 78-84.
58. Rahi, S. (2015). Moderating Role of Brand Image With Relation to Internet Banking and Customer Loyalty: A Case of Branchless Banking. *The Journal of Internet Banking and Commerce*, 20(3).
59. Rahi, S. (2016a). Impact of Customer Perceived Value and Customers Perception of Public Relation on Customer Loyalty with Moderating Role of Brand Image. *The Journal of Internet Banking and Commerce*, 21(2), ---.

60. Rahi, S. (2016b). Impact of Customer Value, Public Relations Perception and Brand Image on Customer Loyalty in Services Sector of Pakistan. *Arabian J Bus Manag Review* S2, 004.
61. Rahi, S. (2017). Research design and methods: A systematic review of research paradigms, sampling issues and instruments development. *International Journal of Economics & Management Sciences*, 6(2), 1-5.
62. Rahi, S. (2017). *Structural Equation Modeling Using SmartPLS*: CreateSpace Independent Publishing Platform.
63. Rahi, S. (2018a). *Research Design and Methods*: CreateSpace Independent Publishing Platform.
64. Rahi, S. (2018b). *Technology Adoption Issues in Banks*: CreateSpace Independent Publishing Platform.
65. Rahi, S., & Abd. Ghani, M. (2018a). Does gamified elements influence on user's intention to adopt and intention to recommend internet banking? *International Journal of Information and Learning Technology*, 0(0), null. doi: doi:10.1108/IJILT-05-2018-0045
66. Rahi, S., & Abd. Ghani, M. (2018b). The role of UTAUT, DOI, perceived technology security and game elements in internet banking adoption. *World Journal of Science, Technology and Sustainable Development*, 15(4), 338-356. doi: doi:10.1108/WJSTSD-05-2018-0040
67. Rahi, S., & Ghani, M. (2016). Internet Banking, Customer Perceived Value and Loyalty: The Role of Switching Costs. *J Account Mark*, 5(4), 188. doi: 10.4172/2168-9601.1000188
68. Rahi, S., Ghani, M., Alnaser, F., & Ngah, A. (2018). Investigating the role of unified theory of acceptance and use of technology (UTAUT) in internet banking adoption context. *Management Science Letters*, 8(3), 173-186.
69. Rahi, S., Ghani, M., & Muhamad, F. (2017). Inspecting the Role of Intention to Trust and Online Purchase in Developing Countries. *J Socialomics* 6(1). doi: 10.41 72/2167-0358.1000191
70. Rahi, S., Ghani, M., & Ngah, A. (2018). A structural equation model for evaluating user's intention to adopt internet banking and intention to recommend technology. *Accounting*, 4(4), 139-152.
71. Rahi, S., & Ghani, M. A. (2016). Customer's Perception of Public Relation in E-Commerce and its Impact on E-Loyalty with Brand Image and Switching Cost. *Journal of Internet Banking and Commerce*, 21(3).
72. Rahi, S., & Ghani, M. A. (2018a). *Investigating the Role of E-Service Quality and Brand Image in Internet Banking Acceptance Context with Structural Equation Modeling (SEM-PLS)*. Paper presented at the Economic and Social Development (Book of Proceedings), 30th International Scientific Conference on Economic and Social.
73. Rahi, S., & Ghani, M. A. (2018b). *A Structural Equation Modeling (SEM-AMOS) for Investigating Brand Loyalty and Customer's Intention towards Adoption of Internet Banking* Paper presented at the Economic and Social Development (Book of Proceedings), 29th International Scientific Conference on Economic and Social.
74. Rahi, S., Ghani, M. A., & Alnaser, F. M. (2017). The Influence of E-Customer Services and Perceived Value on Brand Loyalty of Banks and Internet Banking Adoption: A Structural Equation Model (SEM). *The Journal of Internet Banking and Commerce*, 22(1), 1-18.
75. Rahi, S., Ghani, M. A., & Ngah, A. H. (2019). Factors Propelling the Adoption of Internet Banking: The Role of E-Customer Service, Website Design, Brand Image and Customer Satisfaction. *International journal of Business Information System* 0(0).
76. Ramkissoon, H., Uysal, M., & Brown, K. (2011). Relationship between destination image and behavioral intentions of tourists to consume cultural attractions. *Journal of Hospitality Marketing & Management*, 20(5), 575-595.

77. Rosenberg, L. J., & Czepiel, J. A. (1984). A marketing approach for customer retention. *Journal of Consumer Marketing*, 1(2), 45-51.
78. Ross, E. L. D., & Iso-Ahola, S. E. (1991). Sightseeing tourists' motivation and satisfaction. *Annals of Tourism Research*, 18(2), 226-237.
79. Samar, R. (2018). E-Banking Challenges and Opportunities: An Empirical Investigation on Branchless Banking: CreateSpace Independent Publishing Platform.
80. Samar, R., & Mazuri, A. G. (2019a). Does gamified elements influence on user's intention to adopt internet banking with integration of UTAUT and General Self-Confidence? *International Journal of Business Excellence*, 0(0). doi: 10.1504/IJBEX.2019.10016706
81. Samar, R., & Mazuri, A. G. (2019b). Integration of DeLone & McLean and Self-Determination Theory in internet banking continuance intention context. *International Journal of Accounting and Information Management*, 27(3).
82. Samar, R., Norjaya, M. Y., & Feras, M. A. (2017). Measuring the role of website design, assurance, customer service and brand image towards customer loyalty and intention to adopt internet banking. *The Journal of Internet Banking and Commerce*, 22(S8).
83. Samar, S., Ghani, M., & Alnaser, F. (2017). Predicting customer's intentions to use internet banking: the role of technology acceptance model (TAM) in e-banking. *Management Science Letters*, 7(11), 513-524.
84. San Martín, H., & Del Bosque, I. A. R. (2008). Exploring the cognitive–affective nature of destination image and the role of psychological factors in its formation. *Tourism management*, 29(2), 263-277.
85. Schofield, P. (2000). *Evaluating Castlefield Urban Heritage Park from the consumer perspective: destination attribute importance, visitor perception, and satisfaction*. Paper presented at the Tourism Analysis.
86. Shoemaker, S., & Lewis, R. C. (1999). Customer loyalty: the future of hospitality marketing. *International Journal of Hospitality Management*, 18(4), 345-370.
87. Sönmez, S. F., & Graefe, A. R. (1998). Determining future travel behavior from past travel experience and perceptions of risk and safety. *Journal of travel research*, 37(2), 171-177.
88. Tse, D. K., & Wilton, P. C. (1988). Models of consumer satisfaction formation: An extension. *Journal of Marketing Research*, 204-212.
89. Yoon, Y., & Uysal, M. (2005). An examination of the effects of motivation and satisfaction on destination loyalty: a structural model. *Tourism management*, 26(1), 45-56.
90. Yusta, A. I., Monge, E. C., & Vega, A. R. (2008). *The adoption of the internet as a new distribution channel for holiday tourism in Spain: the challenge of consumer perceived risk and consumer attitudes*. Paper presented at the Database and Expert Systems Application, 2008. DEXA'08. 19th International Workshop on.

# THE DEVELOPMENT OF TRADE WITH WHEAT AT THE GLOBAL LEVEL

**Dragos Ion Smedescu**

*University of Agronomic Sciences and Veterinary Medicine of Bucharest, Mărăști Blvd,  
no.59, district 1, 011464, Bucharest, Romania  
smedescudragos@yahoo.com*

**Alexandru Fintineru**

**Valentina Constanta Tudor**

**Cosmina Carbarau**

**Beatris Vasile-Tudor**

## **ABSTRACT**

*The progress of world agriculture has highlighted the contribution of this activity to economic growth. For all countries, agriculture has been a powerful balance factor in harmonizing domestic economic development and settling social conflicts generated by the food problem. The development of agriculture has favored economic growth in the most diverse sectors, contributing to ensuring national independence and food security. World trade in cereals accounts for about 10% of agri-food trade. This percentage is important if we consider that cereals are basic raw materials for the manufacture of agri-food products or as animal feed. The present study analyses the evolution of indicators such as area cultivated, production, average yield and trade with wheat at the global level between 2010 and 2016. In the year 2016, at the worldwide level, the area cultivated with wheat is based on 12 countries which cultivate around 66% of the total area of 220 million hectares.*

**Keywords:** *agriculture, cereals, global commercial exchange, wheat*

## **1. INTRODUCTION**

Wheat is one of the most important plants grown in the world and trade with cereals have been confirmed from 6000-5000 BC (Pânzaru R., 2018). with a great deal of food. The extensive areas occupied with wheat as well as the people's interest in the culture of this plant are due to certain factors, namely the high content of grains in carbohydrates and proteins, the ratio of these substances to the requirements of the human body; long grain consistency and the fact that they can be transported without difficulty; high ecological plasticity, the grains being cultivated in areas with very different climates and soils; as well as the possibility of unbridled mechanization of the culture. Nowadays the wheat culture is cultivated on an area of over 200 million hectares worldwide and is the most used cereal in human food, being considered the best food. Wheat is the most important source of carbohydrates and contains minerals, vitamins, fats, and if added a small amount of protein of plant and animal origin, it becomes very nutritious. As a result of its importance, wheat is cultivated on all continents and the main producers are European Union with France and Germany, followed by the other continents as China, Russia, India, USA, Canada (Popescu A., 2018). World production of wheat reached the record of 592 million tons in 1990 and has since remained relatively constant.

## **2. MATERIALS AND METHODS**

Documentation, analysis and data processing are the main research methods used in making this study. The methods are based on synthesis, analogy and comparative analysis.

Once the information has been identified, known and interpreted, the next step was the detailed documentation of the field of interest. The data used in this study was mainly provided by Faostat and Intracen. Documentation also involved comparing the different sources studied.

### 3. RESULTS AND DISCUSSIONS

Wheat is a strategic food both for humans and animals and nevertheless, an important raw material for food processing industry (Popescu A., 2018). Worldwide, India ranks first as a wheat-growing area, in 2016 cultivating 30.2 million ha. Russia became the second largest wheat cultivator in 2015, outpacing China, so in 2016 the cultivated area was 27.3 million hectares. The third largest wheat cultivator is China with an average area of 24.2 million hectares. The US also occupies a leading position, in 2016 the cultivated area being 17.7 million hectares, but declining compared to 2010, when it was 19.2 million hectares. Given these, it is noted that in the world, in 2016, the main 12 countries cultivated about 65.9% of the total area under wheat. In Romania, in the absence of a functional irrigation system, the romanian farmers are mostly dependent on the weather conditions (Tudor V., 2017).

*Table 1: The global area cultivated with wheat in 2010-2016 (hectares)*

HECTARES	2010	2011	2012	2013	2014	2015	2016
GOBAL	215.500.007	220.487.954	217.774.417	218.735.766	221.263.451	222.157.081	220.107.551
UE 28	55.811.533	59.279.008	54.893.167	57.870.395	58.718.384	61.512.042	62.519.609
SUA	19.270.930	18.496.174	19.797.644	18.345.410	18.771.550	19.058.470	17.761.840
CHINA	24.257.900	24.272.245	24.270.311	24.119.335	24.071.629	24.144.516	24.348.396
FRANCE	5.426.820	5.407.328	5.297.826	5.319.778	5.297.210	5.480.208	5.562.553
CANADA	8.296.100	8.552.500	9.497.200	10.441.500	9.480.100	9.577.400	9.261.600
INDIA	28.457.400	29.068.600	29.860.000	29.650.000	30.470.000	31.470.000	30.230.000
AUSTRALIA	13.881.030	13.501.780	13.902.140	12.979.382	12.613.226	12.383.673	11.282.202
UKRAINE	6.284.100	6.657.300	5.629.700	6.566.100	6.010.600	6.839.500	6.205.800
BRAZIL	2.181.567	2.138.916	1.912.711	2.087.395	2.834.945	2.472.628	2.166.170
ARGENTINA	3.325.457	4.582.575	4.560.213	3.060.199	5.031.385	4.027.467	5.629.213
RUSSIA	21.639.828	24.835.516	21.277.882	23.371.410	23.907.772	25.870.340	27.312.777
GERMANY	3.297.699	3.248.200	3.056.700	3.128.200	3.219.700	3.282.700	3.201.700
ROMANIA	2.152.523	1.945.849	1.992.180	2.097.490	2.107.813	2.102.444	2.135.304

*Source: Projection after data provided by FAO, 2018,  
<http://www.fao.org/faostat/en/#data/QC>*

Analyzing the share of wheat landed in the world in 2016, it can be seen that India holds 22% of the total, followed by Russia with 19%, China with 18%, the USA with 12%, Australia with 8%, Romania cultivating 1% of the total wheat area worldwide.

*Figure following on the next page*

Figure 1: The share of areas cultivated with wheat in the world in 2016

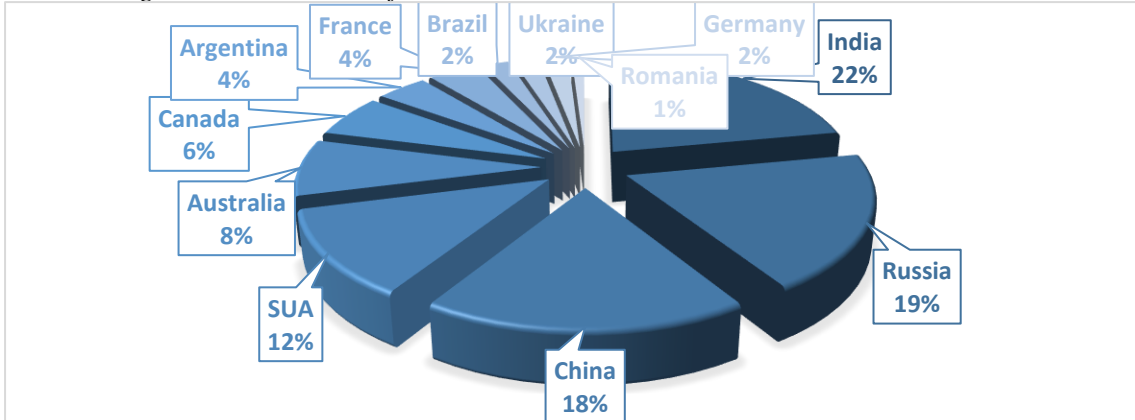

Source: Projection after data provided by FAO, 2018 regarding wheat cultivated areas in 2016.

In 2010, total wheat production worldwide amounted to 640 million tons on a cultivated area of approximately 215 million hectares, with an average yield per hectare of 2.9 tons, and in 2016 there was an increase in total production of 749 million tons, and a cultivated area of 220 million hectares with a production yield of 3.4 tons per hectare. China is the largest wheat producer in the world, with a production of 131.6 million in the year 2016, up from 2010 when the total production was 115.1 million tons. The world's second largest wheat producer is India, in the year 2016 it recorded a production of 93.5 million tons, 12.7 million more than in 2010, when total production was 80.8 million tons. In 2016 total wheat production recorded by the top 12 countries accounted for a total of 68% of world production.

Table 2: World wheat production between 2010-2016 (tons)

TONS	2010	2011	2012	2013	2014	2015	2016
GLOBAL	640.327.135	697.697.675	672.724.051	710.956.882	733.534.429	736.984.917	749.460.077
UE 28	201.374.051	224.034.725	195.049.037	226.106.720	249.257.534	257.618.057	250.126.499
SUA	60.062.408	54.418.808	61.677.384	58.104.610	55.147.120	55.839.540	62.859.050
CHINA	115.186.178	117.414.034	121.030.059	121.930.527	126.215.211	130.192.335	131.696.392
FRANCE	38.207.431	35.992.794	37.885.742	38.651.472	38.950.202	42.750.027	29.504.454
CANADA	23.299.600	25.288.000	27.205.200	37.529.600	29.419.600	27.594.100	30.486.700
INDIA	80.803.600	86.874.000	94.880.000	93.510.000	95.850.000	86.530.000	93.500.000
AUSTRALIA	21.834.010	27.410.076	29.905.009	22.855.576	25.303.037	23.742.560	22.274.514
UKRAINE	16.851.300	22.323.600	15.762.600	22.279.300	24.113.970	26.532.100	26.098.830
BRAZIL	6.171.250	5.690.043	4.418.388	5.738.473	6.261.895	5.508.451	6.834.421
ARGENTINA	9.016.373	16.067.929	14.683.475	8.134.409	14.143.425	11.571.228	18.557.532
RUSSIA	41.507.581	56.239.994	37.719.640	52.090.797	59.711.382	61.785.799	73.294.568
GERMANY	23.782.955	22.782.700	22.409.300	25.019.100	27.784.700	26.549.500	24.463.800
ROMANIA	5.811.810	7.131.590	5.297.748	7.296.373	7.584.814	7.962.421	8.431.131

Source: Projection after data provided by FAO, 2018,  
<http://www.fao.org/faostat/en/#data/QC>

Analyzing the share of total world wheat production in 2016, it can be seen that China holds 23% of the total, followed by: India 18%, Russia 14%, US 12%, France 6%. Romania holds 2% of total wheat production worldwide.

Figure 2: The share of wheat production worldwide in 2016

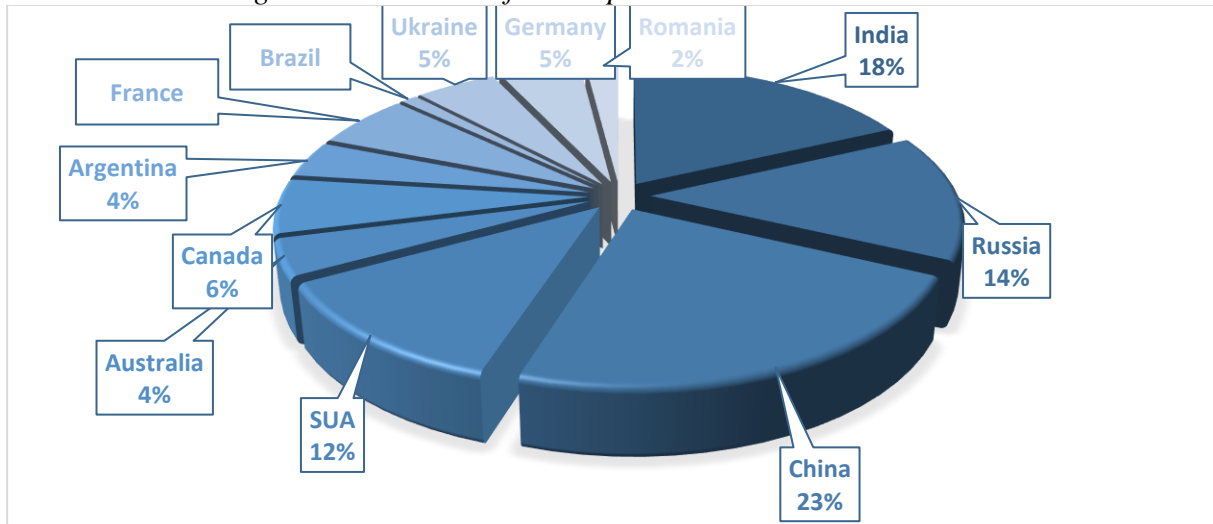

Source: Projection after data provided by FAO, 2018 regarding wheat production worldwide in 2016

Wheat production is dependent on the general genetic potential of the plant, which in turn is at the expense of productivity. Elements of productivity are in turn complex features, which have a polygenic determinism, conferring the specificity of each genotype. The productivity of the cultivar is dependent on the hereditary factor, on which the environmental conditions and the environment of the genotype-environment play a major role in phenotypic expression. The production of wheat is therefore a quantitative character with high variability which is given by many components of production, their formation under the influence of environmental conditions. At the global level, the average wheat production trend had an upward trend, so in 2010 the average production was 2.97 tons, reaching 20.4 tons in 3.4 tons. Germany is the country with the best average yield per hectare worldwide in 2016, with a production of 7.64 tons, the peak reached in 2014 by 8.63 tons.

Table 3: Average yield of cultivated wheat (tons / hectare)

TONS	2010	2011	2012	2013	2014	2015	2016
GLOBAL	2,97	3,16	3,09	3,25	3,32	3,32	3,40
UE 28	3,61	3,78	3,55	3,91	4,24	4,19	4,00
SUA	3,12	2,94	3,12	3,17	2,94	2,93	3,54
CHINA	4,75	4,84	4,99	5,06	5,24	5,39	4,73
FRANCE	7,04	6,66	7,15	7,27	7,35	7,80	5,30
CANADA	2,81	2,96	2,86	3,59	3,10	2,88	3,29
INDIA	2,84	2,99	3,18	3,15	3,15	2,75	3,09
AUSTRALIA	1,57	2,03	2,15	1,76	2,01	1,92	1,97
UKRAINE	2,68	3,35	2,80	3,39	4,01	3,88	4,21
BRAZIL	2,83	2,66	2,31	2,75	2,21	2,23	3,16
ARGENTINA	2,71	3,51	3,22	2,66	2,81	2,87	3,30
RUSSIA	1,92	2,26	1,77	2,23	2,50	2,39	2,68
GERMANY	7,21	7,01	7,33	8,00	8,63	8,09	7,64
ROMANIA	2,70	3,67	2,66	3,48	3,60	3,79	3,95

Source: Projection after data provided by FAO, 2018,  
<http://www.fao.org/faostat/en/#data/QC>

Between 2010 and 2016, average wheat production worldwide has been steadily rising, reaching 20,40 tons per hectare, but below the EU average production of 4 tons per hectare.

Figure 3: Average yield of cultivated wheat (tons / hectare)

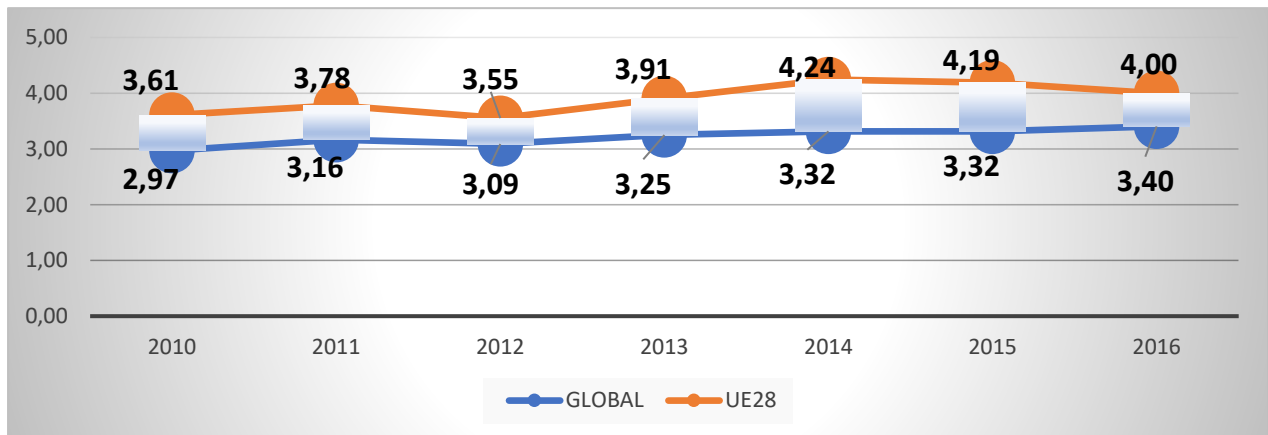

Source: Projection after data provided by FAO, 2018

Between 2011 and 2016, world grain trade had a differentiated dynamic. Thus, between 2011 and 2013 it intensified and in the next two years of the analysis (2014 and 2016) regressed, but imports significantly exceeded exports throughout the analyzed period. The statistical data for 2016 show a sharp drop in both grain exports, 24 percent versus 2011, to \$ 96 billion, and imports by 26 percent to \$ 100 billion. During the analyzed period, the trend of world grain trade was unevenly distributed between the major regions of the globe, meaning that the trade of the developed countries was the factor of boosting the trade of the developing countries.

Figure 4: Exports and imports of cereals worldwide during 2010-2016

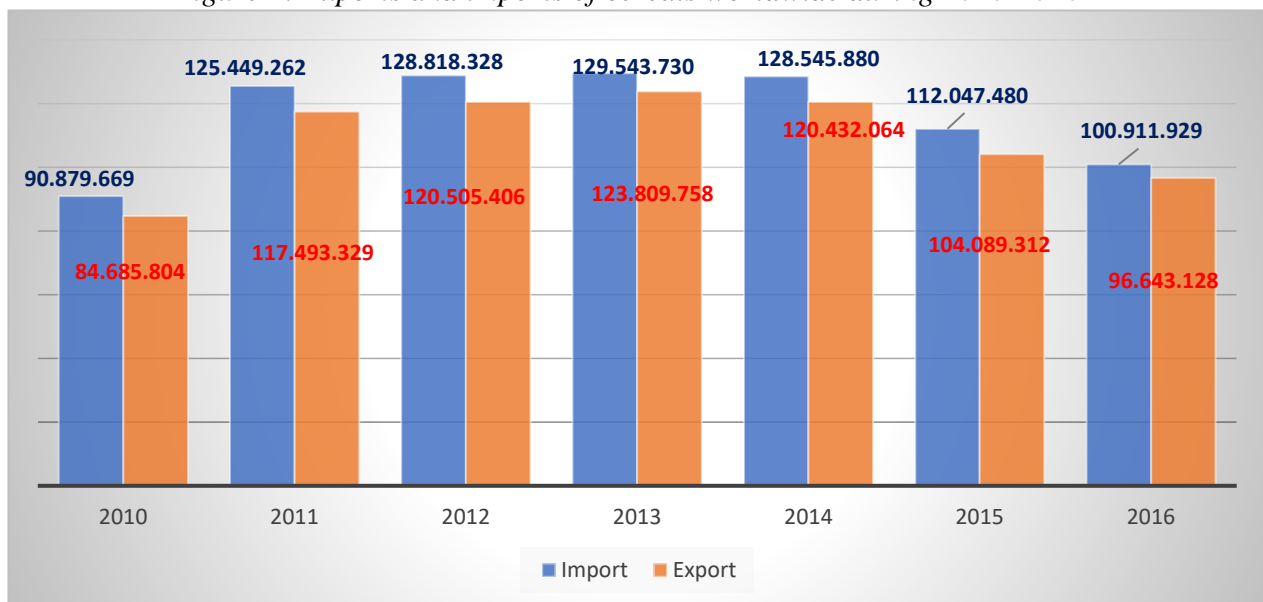

Source: Personal representation based on data provided by the ITC (2018).

According to Intracen Database, during 2010-2016, the volume of deliveries on the international market of the main cereal exporting countries/regions had relatively significant fluctuations. Of these, the United States and the EU-28, with individual shares of more than 23% each in world trade, reached maximum sales on foreign markets of \$ 28.3 billion in 2010 for the United States, and about \$ 30 billion (31.5 million tons) in 2013 for the EU-28.



*Table 4: Global grain exports in 2010-2016 (\$ thousand)*

EXPORTERS	Export value in 2010	Export value in 2011	Export value in 2012	Export value in 2013	Export value in 2014	Export value in 2015	Export value in 2016
GLOBAL	84.685.804	117.493.329	120.505.406	123.809.758	120.432.064	104.089.312	96.643.128
UE 28	20.587.102	26.773.477	25.748.285	29.969.515	28.052.670	25.095.125	22.308.702
USA	20.036.820	28.347.941	20.616.227	20.300.976	22.850.742	18.799.966	19.000.075
RUSSIA	2.396.097	4.438.710	6.251.741	4.752.137	7.086.716	5.652.551	5.606.085
ARGENTINA	4.621.948	8.153.324	9.529.615	8.312.033	5.237.409	4.842.169	6.975.113
AUSTRALIA	4.705.079	8.065.036	8.667.000	8.155.909	7.473.083	6.517.537	5.079.582
UKRAINE	2.467.061	3.617.212	6.971.048	6.371.335	6.544.132	6.057.490	6.300.811
CANADA	5.577.341	7.046.181	7.522.699	8.072.446	8.753.950	7.336.351	5.623.477
INDIA	2.923.681	5.371.013	8.729.057	11.592.455	10.059.331	6.846.427	5.554.785
FRANCE	7.677.738	10.863.387	8.951.361	10.846.818	9.020.893	7.997.969	6.220.951
BRAZIL	2.606.445	4.032.748	6.551.761	7.068.140	4.438.189	5.724.924	4.109.624
GERMANY	2.828.734	3.221.669	3.320.433	4.325.026	3.851.225	3.405.816	2.873.697
ROMANIA	1.171.957	1.467.417	1.714.358	2.651.043	2.638.730	2.225.882	2.326.568

*Source: Projected after data provided by ITC 2018 <http://www.intracen.org/itc/market-info-tools/statistics-country-product/>*

According to Intracen Database, worldwide, between 2010 and 2016, the average annual import of cereals in total agricultural products was around 9%, with Asia (45%) accounting for the highest percentages. If China was not part of the largest grain importer by 2010, it was ranked 5th by 2012, so that in 2013 it would raise two positions and in the last year of analysis became the main international buyer as a result of significant increases in the consumption of sorghum (five times), barley (2.2 times) and rice (by 3.2%). Under these circumstances, the purchases on the foreign market of these cereals have increased substantially, three times in barley, to 6.2 million tons (\$ 2.9 billion). The EU ranks among the top 20 major grain-importing countries due to the top positions of the five-member countries: Italy, Spain, Germany, the Netherlands. In the period 2010-2016, the EU average annual cereal imports in the world total is 19%, with a total value of \$ 117 billion, compared to 95 million tons.

*Table 5: The main grain importing countries in 2010-2016 (thousand \$)*

IMPORTERS	Import values in 2010	Import values in 2011	Import values in 2012	Import values in 2013	Import values in 2014	Import values in 2015	Import values in 2016
GLOBAL	90.879.669	125.449.262	128.818.328	129.543.730	128.545.880	112.047.480	100.911.929
EU	17.433.706	24.222.664	23.622.329	25.201.844	24.101.957	20.598.139	19.728.248
CHINA	1.501.286	2.015.943	4.750.662	5.053.759	6.174.890	9.347.989	5.661.089
JAPAN	6.952.235	9.650.798	8.724.943	8.567.456	6.931.611	5.949.956	5.326.725
MEXIC	3.234.713	5.476.342	5.441.889	4.301.496	4.258.809	4.005.351	4.216.602
EGYPT	3.483.899	5.452.688	5.349.071	4.729.381	5.052.235	4.365.428	3.105.216
INDONESIA	2.159.218	4.753.078	3.714.353	3.621.450	3.605.888	3.156.120	3.191.825
ITALY	2.712.703	4.007.098	3.205.838	3.648.386	3.996.181	3.199.999	3.055.044
SPAIN	2.397.595	3.406.809	3.824.202	3.066.041	3.134.697	3.019.418	2.911.992
KOREA	3.338.242	4.625.865	4.603.824	4.832.224	4.204.148	3.707.032	3.212.050
NETHERLANDS	2.358.597	3.305.998	3.257.849	3.752.247	3.258.524	2.859.690	2.598.287
ALGERIA	1.950.573	4.019.858	3.259.391	3.273.090	3.647.317	3.516.568	2.783.057
GERMANY	2.364.562	3.328.292	3.090.708	3.311.255	3.422.835	2.856.613	2.727.107

*Source: Projected after ITC 2018 <http://www.intracen.org/itc/market-info-tools/statistics-country-product/>*

In 2016 the value of global exports was about \$ 36.5 billion, 11% higher than in 2010, when the value of exports was about \$ 32.8 billion. In the series of years under review, grain trade worldwide has been oscillating in terms of exports of wheat products. In 2013, the highest value of exports was recorded, with a 49% increase over 2010, the total value being about \$ 49.1 billion. From 2013 to 2016, the value of world wheat exports declined by 38%, to \$ 36.5 billion. At global level, the value of wheat exports accounts for about one-third of the total value of grain exports. In 2016, wheat exports worldwide amounted to approximately \$ 36.5 billion, of the total value of grain exported in 2016, which was about \$ 96.6 billion.

*Figure 5: The share of wheat exports worldwide in 2016*

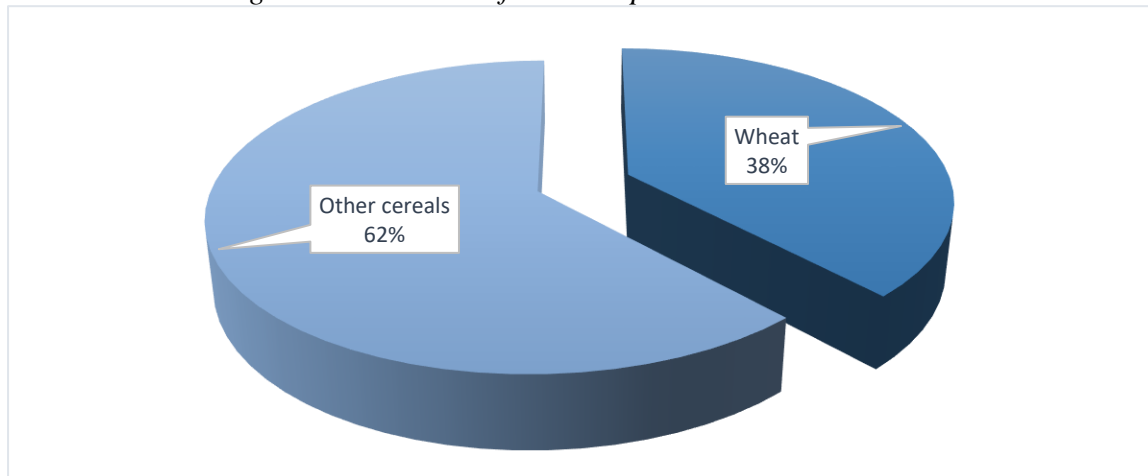

*Source: Personal representation based on data provided by the ITC (2018).*

#### **4. CONCLUSION**

Wheat is one of the most important plants grown in the world, with a great deal of food. As a result of its importance, wheat is cultivated on all continents. The first place in the ranking, according to the area cultivated with wheat in 2016, is occupied by India, with a total area of 30.2 million hectares. The next ranked are Russia with 27.3 million hectares, China with 24.2 million hectares and the US with 17.7 million hectares cultivated. As for production, things are different. Thus, China is the largest wheat producer in the world, registering a total production of 131.6 million tons in 2016. This is followed by India with 93.5 million tons, Russia with 73.2 million tons and the US with 62.8 million tons of wheat. At global level, the average wheat production trend had an upward trend, so that if in 2010 the average production was 2.97 tons, in 2016 it reached 3.4 tons. Germany is the country with the best average yield per hectare worldwide in 2016 with a production of 7.64 tons. During the analyzed period, the trend of world grain trade was unevenly distributed between the major regions of the globe, meaning that the trade of the developed countries was the factor of boosting the trade of the developing countries. National agricultural policies and regional economic development can influence the domestic wheat trade and its associated virtual cropland flows (Xiaolin C., 2018).

#### **LITERATURE:**

1. Pânzaru R.L., Vladu M., Medelele D.M., Bodescu D. 2018, Romania's cereal external trade between 2014 and 2016. Scientific Papers. Series "Management, economic engineering in agriculture and rural development", Vol. 18 issue 1, Print issn 2284-7995, 319-324.
2. Popescu A. 2018, Maize and wheat - top agricultural products produced, exported and imported by Romania. Scientific Papers. Series "Management, economic engineering in agriculture and rural development", Vol. 18 issue 3, Print issn 2284-7995, 339-352.

3. Popescu A., Dinu T.A., Stoian E. 2018, The comparative efficiency in Romania's foreign trade with cereals, 2007-2016. Scientific Papers. Series "Management, economic engineering in agriculture and rural development", Vol. 18 issue 1, Print issn 2284-7995, 371-384.
4. Tudor V.C., Popa D., Gimbaşanu G.F. 2017, The analysis of the cultivated areas, the production and the selling price for maize crops during the preand post-accession periods of romania to the European Union and trends of evolution of these indicators. Scientific Papers. Series "Management, economic engineering in agriculture and rural development", Vol. 17 issue 2, print issn 2284-7995, 387-394.
5. Xiaolin Chen, Xiaojie Liu, 2018, Domestic wheat trade and its associated virtual cropland flow in China, 2010–2015, Sustainability 2018, 10, 1459; doi:10.3390/su10051459;
6. FAO, 2018, <http://www.fao.org/faostat/en/#data/qc>.
7. ITC 2018 <http://www.intracen.org/itc/market-info-tools/statistics-country-product/>

## THE VIRTUAL PRODUCTION LINE AS A MODEL FOR A CREATIVE LABOUR ANALYSIS

**Stanislaw Walukiewicz**

*Faculty of Engineering Management, Bialystok University of Technology, Poland  
s.walukiewicz@pb.edu.pl*

### **ABSTRACT**

*It is useful to divide a work (labour) into routine and creative and define a creative labour as a here and now negation of a routine one. For instance, using computers and the internet was creative in the scientific community (here) some 25 years ago (then), but it is a routine activity in 2018 (now). Scientists who do not use computers and the internet are exceptions that prove the previous sentence here (scientific community) and now (2018). A work of blue collars on the assembly line, brought by Henry Ford in motor industry a hundred years ago, is a commonly used example of a routine labour. We introduce a concept of the Virtual Production Line (VPL) as an extension of the Ford's invention, study its structure, and show how it can be used in an analysis and modelling of creative labour. We also demonstrate that the VPL should be considered as a new example for the ICT support to business activities. By an example of the Linux (system), we demonstrate that each bug fixing or a codebase extension can be considered as an example of a successful or not creative activity, done by at least two developers on a corresponding VPL. The line is virtual, since it does not exist physically and developers may be located in different parts of the world. They join efforts in a given project and exchange information via internet. Thus, there exists the one to one correspondence between a Linux project and its VPL. Then, the motivation and governance in a Linux project can be studied as formal and informal relations among developers working on the corresponding VPL. We generalize these findings to the case of any creative activity and discuss a possible impact of them on labour market in the nearest future.*

**Keywords:** *Assembly line, Creative and routine labour, Labour market, Linux system, Project management*

### **1. INTRODUCTION**

The growth theory (see e.g. Mankiw, 2012, part III) assumes directly that there are only two input variables of a market economy – capital and labour – and that they are of the same importance. I think, it is not the case nowadays. Today, capital in its both forms financial capital and physical capital can be employed easily everywhere and always. It can be demonstrated that the labour market is the most over-regulated main market and such over-regulation is the output of socio-economic development, the direct result of the endless improvement of the division of labour and knowledge (Walukiewicz, 2017). Therefore, I claim that labour (human capital + social capital) is more important production factor than capital (financial capital + physical capital). In other words, people (labour) are unique and the most important actors in any economic activity, particularly in any creative activity, while, nowadays, capital serves as a production factor of the secondary importance. When at least two human capitalists (individuals) collaborate then they create social capital – a new economic category very desired in families, firms and countries. Two machines (physical capital) cannot cooperate without at least one human capitalist (man) who connects them. Similarly, two funds (financial capital) will lay idle until at least one human capitalist decides to use them jointly. I have shown that the value of social capital together with the value of human capital constitute the lion's share of the market value of ICT corporations like Google, Microsoft and Nokia. (see Table 5.1 in Walukiewicz, 2015 for details). Traditional, one-dimensional economics considers only one type of labour – routine labour, which is divided further into low-skilled labour and high-skilled

labour with the assumption that the last equals some multiple of the first. I have introduced a concept of creative labour as a here and now negation of routine labour, and have shown how this concept can be used both in theory and practice (Walukiewicz, 2017). The division of labour into routine and creative one is useful because while the demand for routine labour is shrinking, the demand for creative one is growing, and more and more it becomes a unique source of wealth for a man, family and nation. Since creative labour is, by its definition, unique, then its analysis, evaluation and organization require an entirely new methodology. The main aim of two-dimensional economics, presented in my book (Walukiewicz, 2015) and partially in this paper, is to provide such a methodology. By an example of the Linux system, we demonstrate how such a methodology works. The Linux system, in short Linux, is a (very big) computer program, a result of an open source style work of thousands of developers-volunteers for more than two decades, widely used by commercial companies, government organizations and individual users. The Linux Foundation publishes regularly A White Paper (<http://www.linuxfoundation.org>) under the same precise title Linux Kernel Development. How Fast It is Going, Who is Doing It, What They Are Doing, and Who is Sponsoring It, further called the Report, where it presents the development of the main parts of the Linux system. According to the August 2016 Report, the updated versions of the kernel had more than 20 million lines, and if we print 100 lines per page, then it takes over 200 books, having 1,000 pages each. From the very beginning of Linux, two research questions: (1) why individuals participate in the Linux projects fixing bugs or extending the codebase, and (2) how their work is organized and managed, are considered in numerous papers and books, reviewed in the paper. The paper investigates these two questions from a new theoretical perspective, based on an idea of the Virtual Production Line (Walukiewicz, 2006). Saying it differently, by an example of Linux, we demonstrate how the VPL can be used in an analysis of creative labour. It is useful to divide a work (labour) into routine and creative and define a creative work as a here and now negation of a routine one. For instance, using computers and the internet was creative in the scientific community (here) some 25 years ago (then), but it is a routine activity in 2018 (now). Scientists who do not use computers and the internet are exceptions that prove the previous sentence here (scientific community) and now (2018). A work of blue collars on an assembly line is a commonly used example of a routine labour. This paper demonstrates that each bug fixing or a codebase extension can be considered as an example of a successful or not creative activity, done by at least two developers on the corresponding VPL, discussed in Chapter 3, where among others, we study similarities and differences between the VPL and its classical counterpart. The line is virtual, since it does not exist physically and developers may be located in different parts of the world. They join efforts in fixing certain bugs or extending some parts of a codebase, and exchange information via internet. Thus, there exists the one to one correspondence between a given Linux project and its VPL. Then, the motivation and governance in the Linux project can be studied as formal and informal relations among developers working on the corresponding VPL. In other words, this paper proposes the VPL as a new model for an analysis and evaluation of creative labour done by Linux developers on the corresponding VPL, and generalizes these findings to the case of any creative activity. In the next chapter, we draw from the relevant literature on open source software to formulate our main assumption saying that Linux developers do not receive any tangible (financial) gratification for their contributions. Their gratifications are mostly of intangible character, which can be measured by a utility of cognitive and emotive proximities between them to be discussed in a subsequent paper. Today, many Linux developers work (for money) in software companies like Red Hat, IBM or Microsoft, as the Report indicates, but we need this assumption for methodological reasons to present the idea of the Virtual Production Line in Chapter 3. Our main result says that the Linux system can be considered as a constantly growing tree of Virtual Production Lines.

Generalizing this result, we demonstrate the usefulness of our model in an analysis of any creative activity in a market economy here and now. Among others, we show that the Linux system can be considered as an example of a completely new way of organization and evaluation of creative labour, what in fact is a new way of life. I call it the Linux world.

## 2. THE MAIN ASSUMPTION

For a long time, the open source software was called a 'free software' and the word 'free' has traditionally led commercial software vendors to think 'no revenue' and customers of those firms to think 'no support' (see Bretthauer, 2001 for the history of the 'open source software' term). Thus for a long time, the most in the commercial world saw free software as irrelevant, and free-software developers as idealistic and naïve. Similarly, many free-software advocates have seemed commercial software companies as interested only in short-term profits at the expense of the long-term interests of users and the software development community as a whole. Today these two communities are interlinked closely; open source software has a growing impact on a market economy and on software industry, in particular, and vice versa. The year 2001 can be considered as a turning point in relations between these two communities when Dell Computer, IBM and Oracle have all announced allegiance to Linux products and have offered support services to their customers who operate in a Linux environment (Anonymous, 2001 a, b and c; Gallivan, 2001). The growing success of systems like Android, Apache or Mozilla, to mention a few, demonstrates the potential importance of the open source software to businesses, as both users and for-profit producers of software (Andres, 2002; Curtis et al., 1998; Hansen & Kautz, 2004; Joshi et al., 2007; Sawyer et al., 2008; Williams, 2010). The Linux operating system, developed under the open source model, is a firm base for such a success. The beginning of the Linux operating system is commonly associated with Linus Torvalds, who in 1991, then a Finish student of computer science, wrote his first version of the UNIX kernel in the C language. He worked in a bazaar style often distributing early versions of the kernel and widely using solutions of his predecessors. He was one of the most intensive users of the internet at that time. Raymond in his famous essay *The Cathedral and the Bazaar* called him "a damn fine hacker" (Raymond, 2012, p. 8). In common opinion, he is considered as a founder of the GNU/Linux system that in short is called the Linux (system). The source of the word "Linux" is unclear: while some software developers see it as a combination of "Linus" and "UNIX," the others see it as a recursive acronym of "Linux Is Not UNIX." And in fact it is not, since UNIX has now a historical value, only, while the Linux is a world class computer system with a very bright perspective. For instance, Hecker, 1999 describes eight business models for incorporating open source software into a strategy of a software company and Munga et al., 2009 present a Red Hat and IBM case studies as examples of successful companies (see also Koenig, 2004; Lee & Mendelson, 2008; Lee, 2006). In the mentioned above essay Raymond wrote a famous sentence: Given a large enough beta-tester and co-developer base, almost every problem will be characterized quickly and the fix will be obvious to someone (Raymond, 2012, p. 8). This sentence has been quickly modified to a form: Given enough eyeballs, all bugs are shallow (Raymond, 2012, p. 8), called the Linus's Law. I think the origin of these two sentences is in his observation, called further the Raymond's claim, which at the first glance seems to be counterintuitive, but the Linux system proves it: The developer who uses only his or hers own brain in a closed project is going to fall behind the developer who knows how to create an open evolutionary context in which bug-spotting and improvements get done by hundreds of people (Raymond, 2012, p. 20 and 21). Creating "an open evolutionary context" is a way of organizing of creative work for "hundreds of people" where social capital plays a key role (Walukiewicz, 2008). Obviously, these people use ICT technology, so in fact we have an application of the idea of the Virtual Production Line to be discussed in the next chapter.

To present that idea we will assume that these “hundreds of people” work without any financial (monetary, tangible) gratification. In fact, their gratification is of intangible character, to be discussed in a subsequent paper, which is much more complex than simple monetary wages paid workers for their routine labour on an assembly line. So with our main assumption, we are back to the time of the very beginning of open source software, when “hundreds of people” worked for free contributing to the development of the Linux system. As said nowadays, open source software has a big impact on a market economy as a whole, therefore next we remove this assumption and consider the Virtual Production Line as a model for analysis and evaluation of creative labour in a market economy where money plays a key role.

### 3. THE IDEA OF THE VIRTUAL PRODUCTION LINE

First, we present the systems approach to an analysis of an assembly line, a predecessor of the Virtual Production Line, and next describe the VPL in the same way. The idea of an assembly line was presented by Frederick Winslow Taylor (1856-1915) in his book *Principles of Scientific Management* and Henry Ford (1863-1947) was the first who applied it in motor industry in 1913.

#### 3.1. The Classical Production Line

Before the Ford invention, cars were manufactured in so-called production circles (nets), where a few highly skilled craftsmen produced a car from the beginning to the end using raw materials and parts. The division of labor in the production circle was very flexible and craftsmen could easily substitute for one another. The number of highly skilled craftsmen in a community only limited the productivity of this method. Henry Ford was the first, who put the following observation into practice. If we partition, i.e. divide without overlapping, a complex car manufacturing process into a fixed number of simple operations (jobs) done by blue-collar workers on a line (conveyor belt) as shown in Figure 1, then its productivity will increase and the problem of a limited number of highly skilled craftsmen can be solved. Since then, the idea of the assembly line was subsequently applied in many production and service processes. If we have many production/service lines manned by people or robots, we will combine them for the purpose of our analysis into one production/service line called the Classical Production Line (CPL) pictured in Figure 1.

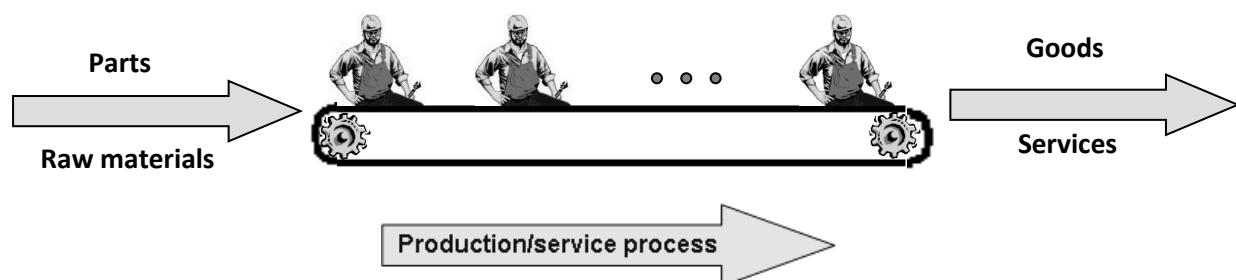

*Figure 1: The Classical Production Line*

Let us assume that a worker, say the second one in Figure 1, has increased his skills (human capital) and now he can do the assigned operation in half the previous time. Does this have any impact on the organization/productivity of the production process concerned? Assuming that he is not a bottleneck, the answer is no. His extra skills may be used in the design and implementation of another production process on another CPL, but not on the one at hand, since its organization is fixed. Thus, we have shown that the CPL does not allow any self-organization and, roughly speaking, workers are there to work, not to think.

So, we can define the CPL as a partition of a complex production/service process into a fixed number of simple operations described to the smallest detail. Such a partition is fixed over time and does not allow any self-organization.

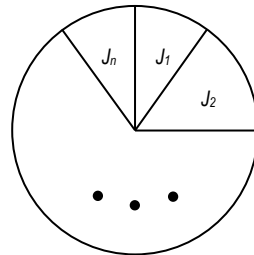

Figure 2: The rigid organization of the CPL

Figure 2 illustrates this definition. The production process, represented by a (full) circle, is partitioned into  $n$  operations (jobs)  $J_1, J_2, \dots, J_n$ . Since the organization of the CPL is rigid, the number of operations over the relevant production process is constant. Although it may be a bit of an exaggeration, we can say that highly skilled craftsmen are not needed in the automotive industry where organization is a priority. Because of excellent organization, simple (manual) workers can produce sophisticated cars. Thus, the CPL is a partition of a given production/service process into a fixed number of operations, and we note that any partition is a division, but not the opposite. Ford combined moving assembly lines with mass routine labour to make building cars much cheaper and quicker – thus turning the automobile from a rich man’s toy into transport for masses. He was one of the first to demonstrate in practice the importance of constant improvement in organization and technology. He introduced the eight-hour workday, for which he paid five dollars, two times more than his competitors did. He would pay \$1,000 in cash to an ordinary worker for a relatively small innovation. The results of his policy were breathtaking: his company produced 189,000 cars in 1914 and more than two million in 1923 – a ten-fold increase in nine years! His innovative management cut the time needed to produce a car from 750 to 93 minutes (Womack et al., 1990, p. 28). In common opinion, Henry Ford is considered as a father of the assembly line, one of the greatest achievements in management science and economics, what has completely changed our life. In Walukiewicz , 2015, I call it the first big jump of the labour productivity.

### 3.2. The Virtual Production Line

Now, we turn back to software production under the open source software model with our assumption that developers do not get any tangible (monetary) gratification for their contributions to the Linux system. Any successful or not attempt to fix bug(s) or extend some part(s) of the codebase is a creative work because it is new (original), done for the first time here (by a team of developers) and now (presently). For obvious reasons, we consider “serious” (large) attempts, further called the (Linux) projects. The lions part of the Linux projects discussed in the literature is successful, while unsuccessful attempts form usually a base for successful projects. So, under the Linux project a team of developers tries to solve a corresponding creative problem connected with fixing bugs or extending the codebase. A remark on the number of people in a project team working on the VPL is necessary at this point. We follow Ghobadi and Mathiassen, 2015, who in their study of knowledge sharing divide an open source team into four groups of managers, developers, testers and user representatives, and call them further experts. So team of experts working on the given VPL is divided into at least four abovementioned groups, and this as usual on the VPL is a division, not a partition of labour, since, for instance, a manager is typically working also as a developer or tester.



The idea of a Virtual Production Line is pictured in Figure 3 where a number of experts with their laptops is connected via the Internet in their attempt to solve a given creative problem under the Linux project. Since there is no material representation of the VPL (experts may be located in different parts of the world), we denote it in Figure 3 using a dashed line, in contrast to Figure 1.

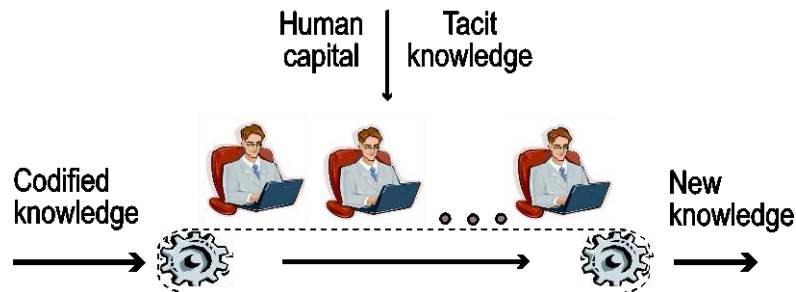

Figure 3: A Concept of the Virtual Production Line

On the VPL, experts combine their human capital, mostly their tacit knowledge (competences, experiences, talents, etc.) with codified knowledge, contained in existing software, data bases, libraries, so forth, in their attempt to solve a problem which, at the beginning, may not be well defined and usually is described in a fussy way, but which, due to their efforts, called jointly self-organization, gets usually more and more clear-cut and distinctive (see Figure 4). In other words, developers on VPL do not only work manually (punch the keys), but – first of all – think.

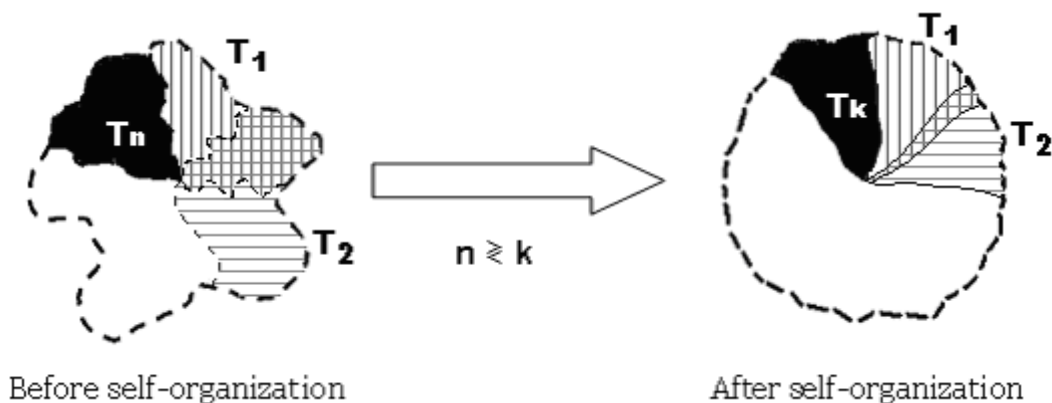

Figure 4: The VPL as a flexible division of labour and self-organization

In Figure 4, we see that at the beginning of the creative process, the problem is not well defined – we mark it with a dashed line along the perimeter. Tasks often overlap each other and their limits are not well delineated – we denote it with a wavy line. After self-organization the problem is usually much better defined (it is almost a circle), the overlapping of tasks are substantially smaller and their limits are almost straight lines. If the problem is initially divided into  $n$  tasks  $T_1, T_2, \dots, T_n$ , then after self-organization, it is divided into  $k$  tasks,  $T_1, T_2, \dots, T_k$ , where  $k$  can be equal, bigger or smaller than  $n$ . We conclude that the VPL allows a flexible division of labour while the CPL is based on a rigid (stiff) partition of labour (see Figure 2) where production or servicing process is well defined to the smallest detail. It is a circle, where the jobs  $J_1, J_2, \dots, J_n$  do not overlap each other, and the limits between them are straight lines as Figure 2 shows. I definitely do not claim that any problem, once defined on the relevant VPL will be solved. I am far from that. I only say that a team on the VPL works in its attempt to solve a given creative problem. Figure 4 shows that in general after self-organization we do not

have a full circle, what corresponds to a solved problem. In Walukiewicz, 2010, I describe the proof of the famous Fermat's Last Theorem as the corresponding VPL. Definitely, there were no computers and neither the internet at that time, but mathematical journals and ordinary letters substituted them very well. Saying it differently, I present the solution of the world's greatest mathematical problem as a chain of self-organizations of the VPL corresponding to that problem. This fascinating story is described in full details by Singh, 1998. So finally, we define the VPL as a division of a given creative process into more or less precisely described tasks combined with modern ICT. The division into tasks, as well as its number, may be changed throughout the process by actions of experts involved in it. Such a modification is called the self-organization of the VPL. Three remarks are necessary at this point. First, on the VPL in contrast to the CPL, we have a division, not a partition of labour (compare Figures 4 with 2). This means that some tasks on the VPL can overlap each other as shown in Figure 4. Such overlapping can be interpreted as a consideration of a given task from different perspectives or from a different science disciplines point of view. It is a natural, basic approach used in any rational analysis. Thus, it is very natural that tasks on the VPL overlap each other in contrast to the fact that jobs on the CPL are disjoint, form a partition, not a division of a given process as shown in Figure 2. We will study this question further in the next subchapter. Second, on the CPL operations or jobs are executed linearly in a fixed, well prescribed order: The second operation is executed only after the first one has been finished. The third job is executed only after the second one has been finished, and so on. Hence, any CPL runs linearly. On the VPL the situation is much more complex because, in general, neither the tasks are executed in a given, already prescribed (planned) order, nor they are executed sequentially. Obviously some task may be executed at the same time (in parallel) and after a self-organization the previous order of tasks may be completely changed, for instance turn upside down. Moreover, we cannot guarantee that a given task will be finished (with its success) because the VPL is an attempt to solve a given creative problem, and the considered task in particular. Therefore, obviously, nobody can guarantee a success in such an attempt. Therefore in general, the VPL runs nonlinearly. In the next subchapter, we show that this nonlinearity forms the essence of self-organization. Third, on the CPL we have a linear assignment of workers to operations, which means that each worker is assigned to one operation (task) only, and each operation is executed by exactly one worker. A mathematician would say at this point that there is one to one correspondence between workers and operations. It can be pictured as a partition of a given production process (full circle in Figure 2) into a fixed already prescribed number of operations. The problem of the optimal (the best possible) assignment of workers to operations is one of the most important questions in operations research and management science. On the VPL, the situation is much more complex as a given expert can participate in many tasks executed in different time, but also may participate in tasks executed at the same time, say the same day, in parallel. Moreover, if we take a day as a natural time unite, then it is quite possible that a given developer works at the same time (day) on different Virtual Production Lines corresponding to problems connected with fixing different bugs or an extension of different parts of the codebase. So, the VPL is a very flexible model for analysis of creative labour.

### **3.3. Self-Organization**

Software development is a collaborative process where success depends on effective knowledge sharing (Walz et al., 1993), and this is particularly true in the case of open source software (Cockburn, 2006, Corvera Charaf et al., 2012, Kautz et al., 2007). In this subchapter, we study relationships between knowledge sharing and self-organization. As said, in contrast to the CPL, the VPL is not a division of labour alone, but a combination of labour division and self-organization with modern ICT. Now, we will discuss these three components in detail beginning with an example pointing out the difference between the VPL and the CPL as its

classical counterpart. To be more specific, consider a group of banking clerks working with credit applications. If everything in their work is described to the smallest detail by the banking procedures, then they are working on the CPL. If they may modify their credit decisions depending on, for instance, the number of applications received, the sums asked, etc., then they are working on the VPL. Obviously, they both use computers and ICT networks in their work here and now. Since a partition of labour is a special case of a labour division into tasks, then the self-organization alone makes the difference between that CPL and VPL. Thus, the self-organization is a key component of any VPL. It follows from our considerations that routine labour is done on the CPL, while creative one, connected with an attempt to solve a given creative problem, on the VPL. Then the following question naturally arises, whether people are alone able to solve creative problems. We know that some animals (dogs, monkeys, etc.) can be trained to solve simple creative problems (to find a way home, count, and so forth). So creative problems can be solved not only by man. But I claim that a human being only can reformulate a given creative problem, which often is a unique way to solve it. In fact, a reformulation of a given creative problem is equivalent to the self-organization of the VPL corresponding to it. When we have a creative problem here and now, then we usually organize a project team, consisting of at least two experts to solve it. Obviously, nowadays the experts divide somehow the labour (project, work) between them and use computers and ICT networks in their work. So they build (form) the corresponding VPL to solve the creative problem in hand. Solving it experts can change the division of the problem into tasks, as well as the number of tasks and the way the tasks are executed (for instance, sequentially or in parallel), which is the essence of a self-organization of the VPL. Since a self-organization (reformulation) is the main component of any VPL and only man is able to reformulate creative problems, then we conclude that only men work on a VPL. Therefore, in contrast to the CPL, the VPL without men working on it cannot exist. Albert Einstein in his famous thought stressed the importance of a reformulation in a rational analysis:

*If I had an hour to solve a problem and my life depended on the answer, I could spend the first 55 minutes figuring out the proper questions to ask. For if I knew the proper questions, I could solve the problem in less than 5 minutes.*

Obviously, "the proper question to ask" is the proper formulation of the problem or, in our terms, the proper self-organization of the VPL corresponding to that problem. This quotation once more points out the importance of self-organization in definitions the VPL. We know that nowadays almost all (creative) problems are solved by project teams working on corresponding VPLs. According to the Einstein's suggestion the time devoted to self-organization is 11 times longer than the time devoted to the solution of a given problem. Now, we would like to point out the importance of ICT in more general context. This is true insofar as we realize that social capital became a subject of serious studies only in the 90's, when we began to be able to send information electronically in any form (data, picture, voice, movie, etc.) to virtually every corner of the world at almost zero cost. I call it the second big jump of labour productivity (Walukiewicz, 2015, Chapter 1). In general, we may define the VPL is an instrument (a virtual conveyor belt) that experts use to combine codified knowledge with their tacit knowledge to produce improvements in products, services, technology and management, and in that way contribute to the world's stock of knowledge, both codified and tacit (see Figure 3). On the VPL experts combine their efforts and use their human capital (knowledge, experience, talent, etc.) in their attempt to solve a given creative problem. As we consider both the Classical Production Line and the Virtual Production Line as methods of analysis of socio-economic reality, therefore we write their names with capital letters.

### 3.4. A Comparison of the CPL with the VPL

As a summary of this section, a comparison of the Classical Production Line with its virtual counterpart is given in a form of Table 1.

*Table 1: Comparison of the CPL with the VPL*

Item	Attribute	CPL	VPL
1	Modelling	Routine labour	Creative labour
2	Organization	Rigid	Flexible
3	Geographic proximity	Very important	Not important
4	Other types of proximity	Not important	Very important
5	Self-organization	None	Very important
6	Number of operations/tasks	Fixed	Variable
7	Partition/division	Partition	Division
8	Management structure	Vertical	Horizontal
9	Control/monitoring	Control	Monitoring
10	Motivation	Direct	Direct and indirect

1. Modelling. The CPL is a tool (method) for modelling and analysis of routine labour (activity), while the VPL is used to model and analysis of creative process, connected with a successful or not solving a given creative problem by a project team consisting of at least two experts.
2. Organization of the CPL is rigid and no change in its organization is allowed during its run. Since any change requires some thinking, then we formulate it in a bit brutal way as on the CPL, workers are to work, not to think. The management is to think, and if it finds it necessary, then it stops the given CPL, changes, for instance, the number of operations, their sequence, etc., and finally starts it again. But then it will be a completely new CPL with its new, own rigid organization. On the contrary, experts on the VPL are, first of all, to think, to self-organize their creative labour, what is called the self-organization, the key component of any VPL. They are completely free in their decisions on the division of the creative process into tasks, the number of tasks, the way they are executed, etc., as we discussed it in Subchapter 3.2.
3. Geographical proximity is an essence of any CPL. Workers on the CPL work as close physically as possible – simply to do not disturb each other. Any violation of the above rule will decrease the productivity of a given CPL. Geographical distances are not important on a VPL, since nowadays we can send information to any point of the world practically at zero cost.
4. Other types of proximity are simply not important on a CPL, while they are very important on any VPL, and we will discuss them in detail in a subsequent paper.
5. Self-organization is by definition the key component of any VPL. In the previous subchapter we show that self-organization is equivalent to problem reformulation, an approach used in any scientific (rational) analysis of the reality from the very beginning of the humanity. I claim that we are living in the world of Virtual Production Lines, although the name is yet not popular, but it is matter of time. On some of them we are working, while the other simply surrounds us. In my opinion, the self-organization of many such lines requires substantial improvements.

6. Number of operations/tasks is fixed on the CPL, while it can be changed during a self-organization of a given VPL.
7. Partition/division. The partition of a production/service process into disjoint jobs (operations) is the essence of any CPL, while on a typical VPL we have a division of a creative process into tasks, which often overlap each other. Such overlapping can be seen as a consideration of a given problem from different perspective.
8. Management structure. The management structure of the CPL is vertical: on the top we have its management, which may be multilevel, and on the bottom workers (blue collars) executed strictly prescribed jobs (operations). The situation on a VPL is much more complex and completely different – its management structure is horizontal.
9. Control/monitoring. The difference between the CPL and the VPL follows directly from the considerations in the point above. On the CPL we have control, while on the VPL – monitoring.
10. Motivation. Direct motivation is mostly used on the CPL – workers' wages depend heavily on time spent by them in the factory, on the CPL, to be precise. The gratification of experts working on a VPL depends mostly on its output and it also contains some indirect factors, for instance the possibility of professional development, respect, etc.

Finally, we note that on the VPL experts learn from each other in their attempt to solve a given problem, *i.e.* they increase the value of their human capital both in singular and plural form (see Walukiewicz, 2012 and 2014) as well due to the synergy effect they increase the value of their social capital. Therefore, a Virtual Production Line is not only a method for an analysis of social capital in action, but also a device for increasing the value of both social and human capital. As a father of this idea I cannot resist to say that is so useful device that it should be developed – so I did this in Spring 2006.

#### **4. CONCLUSION**

We introduce the division of labour into creative and routine one, and describe the VPL as a model for an analysis and evaluation of any creative activity. Nowadays, the demand for routine labour shrinking, since a lot of products are manufactured in fully automated factories, and such a trend is well recognized and stable. For instance, the first man who touches a typical laptop is its buyer who repacks it. Many such laptops are used in creative works organized and motivated in a completely new way. Typically creative labour is executed in project-oriented teams of experts who use their laptops and the internet to exchange information. So they are working on the VPL corresponding to a given creative project. To point out the difference between the routine and creative labour we compare the CPL with the VPL in Subchapter 3.4. By an example of Linux, we demonstrate how the VPL can be used in modelling and analysis of creative labour. Linux as a such, can be thought as one of the biggest creative projects in the history of humanity, executed by experts teams working on the thousands of different Virtual Production Lines, which together form a constantly growing tree of such lines. These findings can be generalized to the case of any creative activity or the case of open innovation.

#### **LITERATURE:**

1. Andres, H.P. (2002) A comparison of face-to-face and virtual software development teams. *Team Performance Management*, 8, 39-48.
2. Anonymous (2001a) Dell and Oracle sign Linux server development pact. *New York Times*, February 1.
3. Anonymous (2001b) Tech firms crowd Linux conference. *New York Times*, February 1.
4. Anonymous (2001c) IBM says Linux is ready for prime-time. *New York Times*, February 4.

5. Bretthauer, D. (2001) Open source software: A history. *UConn Libraries Published Works*. Paper 7.
6. Cockburn, A. (2006) Agile Software Development: The Cooperative Game (Agile Software Development Series), Addison-Wesley Professional, Boston.
7. Corvera Charaf, M., Rosenkranz, C. & Holten, R. (2012) The emergence of shared understanding: applying functional pragmatics to study the requirements development process. *Information Systems Journal*, 23, 115-135.
8. Curtis, B., Krasner, H. & Iscoe, N. (1988) A field study of the software design process for large systems. *Communications to the ACM*, 31, 1268-1287.
9. Gallivan, M.J. (2001) Striking a balance between trust and control in a virtual organization: a content analysis of open source software case studies. *Information Systems Journal*, 11, 277-304.
10. Ghobadi, S. & Mathiassen, L. (2015) Perceived barriers to effective knowledge sharing in agile software teams. *Information Systems Journal*,
11. Hansen, B.H. & Kautz, K. (2004) Knowledge Mapping: A Technique for Identifying Knowledge Flows in Software Organizations, Springer, Berlin.
12. Hecker, F. (1999) Setting up shop: the business of open source software. *IEEE Software*, 16, 45-51.
13. Joshi, K.D., Sarker, S. & Sarker, S. (2007) Knowledge transfer within information systems development teams: examining the role of knowledge source attributes. *Decision Support Systems*, 43, 322-335.
14. Koenig, J. (2004) Open Source Business Strategies. Riseforth Inc.
15. Kautz, K., Madsen, S. & Nobjerg, J. (2007) Persistent problems and practices in information systems development. *Information Systems Journal*, 17, 217-239.
16. Lee, D. & Mendelson, H. (2008) Divide and conquer: competing with free technology under network effects. *Production and Operations Management*, 17, 12-28.
17. Lee, J.A. (2006) Government policy toward open source software: the puzzles of neutrality and competition. *Knowledge, Technology & Policy*, 18, 113-141.
18. Mankiw, G.N., 2012. *Macroeconomics*, 8th Edition, Houndmills, England: Macmillan.
19. Munga, N., Fogwill, T. & Williams, Q. (2009) Adoption of open source software in business models: a Red Hat and IBM case study. SAICSIT'09 Proceedings of the 2009 Annual Conference of the South African Institute of Computer Scientists and Information Technologists, 112-121, ACM, New York.
20. Raymond, E.S. (2012) The Cathedral and the Bazaar. Retrieved 18 April.
21. Sawyer, S., Guinan, P.J. & Coopider, J. (2008) Social interventions of information systems development teams: a performance perspective. *Information Systems Journal*, 20, 81-107.
22. Singh, S. (1998) FERMAT'S ENIGMA. The Epic Quest to Solve the World's Greatest Mathematical Problem, 1st Anchor Book, New York.
23. Taylor, F.W. (1911) The Principles of Scientific Management. Harper & Brothers, New York.
24. Walukiewicz, S. (2006) Systems Analysis of Social Capital at the Firm Level. *Working Paper WP-1-2006*, Systems Research Institute, Polish Academy of Science, Warsaw.
25. Walukiewicz, S. (2008) The dimensionality of capital and proximity. *Proceedings of ERSA 2008 Conference*, Liverpool, August 27-31.
26. Walukiewicz, S. (2010) Kapitał ludzki (in Polish: Human Capital), Systems Research Institute, Polish Academy of Science, Warsaw.
27. Walukiewicz, S. (2012) Kapitał społeczny (in Polish: Social Capital), Systems Research Institute, Polish Academy of Science, Warsaw.
28. Walukiewicz, S. (2014) The market triple, *CEJOR*, 22, 713-727.

29. Walukiewicz, S. (2015) Two-Dimensional Economics. A manuscript, Systems Research Institute, Polish Academy of Science, Warsaw.
30. Walukiewicz, S (2017). The Market Triple as a New Tool in Economics, *Modern Management Forum*, 1(2).
31. Walz, D.B., Elam, J.J. & Curtis, B. (1993) Inside a software design team: knowledge acquisition, sharing, and integration. *Communications of ACM*, 46, 63-77.
32. White Paper (2016) Linux Kernel Development. How Fast It is Going, Who is Doing It, What They Are Doing, and Who is Sponsoring It 25<sup>th</sup> Anniversary Edition, Authors: Corbet, J. and Kroah-Hartman, G. (<http://www.linuxfoundation.org>) Referred as the Report.
33. Williams, C. (2010) Client-vendor knowledge transfer in IS offshore outsourcing: insights from a survey of Indian software engineers. *Information Systems Journal*, 21, 335-356.
34. Womack, J.P., Jones, D.T. & Roos, D. (1990) *The Machine That Changed the World*, Rawson Associates.

## POST-FORDISM AS A SOCIO-ECONOMIC CHANGE IN “TRANSITION” SOCIETIES

**Wieslaw Tadeusz Poplawski**

*Engineering of Management Department*

*Bialystok University of Technology, Bialystok, Poland*

*tpoplaw@tlen.pl*

### **ABSTRACT**

*The essay is analyzing the new perspective of transition societies in the former socialistic and Soviet states through its history from state socialism to current hybrid model of in-between socialism and capitalism. Postfordist type of transition created subcontractors from all the transition countries (now mostly members of EU) and made them subordinated participants of multinational chains, dependent on international companies. This tendency has had a very important impact on the whole socio-economic process. All post-socialistic societies had an idealistic hope to establish an economic system of social justice. However, the real transition took a direction of changes, which were not expected by its citizens. A dream of welfare of social market economy and state-providence have become the reality of liberal capitalism (capitalism of subcontractors), As some countries adopted to the model of postfordist dependent development, the other transition societies had implemented an oligarchic model. In this system a social order has been ideologically based on foundation of an idealistic vision of “the golden age” (e.g. idealized welfare of soviet past).*

**Keywords:** *Change, Transition, Post-Fordism, Subcontractors, Peripheral State*

### **1. INTRODUCTION**

In this essay I will try to explain relations between concepts such as: social change, transition management, postfordism in capitalist supply chains, lean management and peripheral state and ideology. Replacing state socialism with peripheral capitalism has never been a simply task. Especially, in a chain of global change in terms of numerous democratic movements and socio-economics revolutions. A complex definition of transition by Jan Rotmans and René Kemp was expressed as: “In general, a transition can be defined as a long-term, continuous process of change during which a a society or a subsystem of society fundamentally alters. A transition can be described as a set of interconnected changes reinforcing each other and influencing in different areas, such as technology, economy, institutions, ecology, culture, behavior and a system of beliefs. A successful transition is a spiral that reinforces itself, driven by multiple causalities and co-evolution. A prerequisite for transitions to occur is that several developments in different domains at different scale-levels come together to with each other.” (Rotmans, Kemp, 2003)

### **2. A IDEALISTIC VIEW OF HISTORY AND A REAL PROCESS OF TRANSITION**

However, an unrealistic point of view and a common persuasion/conviction that social change is easy to manage and does not create too much problems was presented by many prominent intellectualists and politicians involved in the European transition, like Vaclav Havel or Karol Modzelewski. K. Modzelewski wrote about “riding a mare of history”, where intellectuals play a role of main ‘historical actors’ in a process of changing the reality of Europe (Modzelewski, 2013). Mostly presented as a idealistic vision of history, which is driven from brutal, totalitarian “communism” to a state of social welfare and to the economy/the world of human goals. What is more, there was no another way to survive, but to regulate the social situation than to introduce, harsh measures for the society and the state of peripheral capitalism. Actually, this leads to a claim that the early years of transition were understood as a moment of “taking the



matters into one's own hands". Popularization of this, quite a idealistic pattern was a result of living among ideological catchwords, relating to social market economy and "idealistic model of capitalism" (following an expression of Polish sociologist Strzelecki - "lyrical model of socialism"). The idea of "a destination point" as a concept for developing the market economy was socially accepted as legitimized. In fact, this happened thanks to the idealization of individual entrepreneurship as well as rationalization that transition is unavoidable and truly creative in comparison to dullness, poverty and mediocrity of socialistic reality of the previous decades. In some cases also the process of entering to the EU helped, because it opened the peripheral states to challenges of free and well organized, external markets. The transition economies, which had no such experience were in an inferior situation, drifting into an oligarchic social systems, mostly paralyzed by general tendencies to corruption and an abuse of power. All post-socialistic societies with their attitudes related to transition have lost an optimistic view that state has something to offer to them. The emerging reality has had nothing in common with the idea of state-providence in the West. They understood this notion bringing back to life an upgraded version of "golden age" of previous socialistic system. In reality, such doubts led to change in people's thinking. The foundation of new attitude was faith in one's own strength, self-reliance and future shaped completely on one's own. Unfortunately the generation of the transition period did not see their future through rose-tinted glasses. Just the opposite way, they saw it as a stage of sacrificing themselves for their children's good. The past 28 years of transition were period of one's generation both – glorious and unfortunate days in every-day reality, coined by their own hands. In their daily life full of fatigue it was regularly coming up to their minds that "the historical actors" can hardly ever change something on the scene of historical determinism. It is worth emphasizing that even the Ukrainian conflict, the ongoing war for transition (following Polish and West European example) cannot be understood, unless we grasp the essence of historical processes in the field of the peripheral capitalism, which determines the fate of individuals, creates a community and social situations and defines "the historical actors". Indeed, this is the crucial key to understand witnesses of history, who tried to adopt to conditions and to analyze their future in order to make it predictable. The idealistic idea of welfare state and social market economy in the European sense enlightened the path, which was chosen by the members of transition generation to achieve their goals. The goals, which were understood in a very individual way. It seemed rather obvious that the surrounding reality should be perceived through a prism of the past concepts and circumstances, which as kind of "glasses" disclose not only hazy and deformed, but simply a false image of post-revolutionary future. Obviousness was crossing the boundary awareness. It made kind of "a windbreak", behind which the ideas of the new, social and economic reality gave meaning to lives of "the actors" of the transition years. This kind of "windbreak" let people cope with a fear of enormous change in their biography. Otherwise, the fear would paralyze capabilities to adapt to this enormous change. It can be clearly observed in countries, where social change happened based on old definitions, which either do not match the new reality or are not useful to plan new tasks. Frightened human masses refused to act according to the principles of change, because they've seen no sense in it. This transition full of odd and bizarre orders and rules has left them full of resentments, lost in the past, clueless. To this day, the Belarusian society is more and more immersed in outdated and bizarre definitions, which seem to be very distant from the actual reality. A post-soviet Belarusian being still in practice a Soviet man does not match in any aspect to postmodern presence, which functions not only as an ideological form, but also as a social reality. Furthermore, they treat another part of the world as ideologically strange. So, it can be legitimized and described as "not from the contemporary world" either political as well as in economic aspect. The society "in-between", neither socialistic nor capitalistic, is stuck in ideological clearance, in an "aletheia" quoting Heidegger.

### 3. AN OVERVIEW OF THE ROLE OF SOCIAL AWARENESS IN THE TRANSITION PROCESS

It is worth considering, why our libertarian ideology matches today's reality better than the Belarusian way of thinking. This question seems rather obvious, but it is just a guise. The answer lies somewhere between the vicinity of "Solidarity", Brazilian or Vietnamese 'economic miracle' and even, quite fresh, symbolical handshake of Barrack Obama and Raul Castro. The answer will turn out surprising unless we analyze it scientifically to reply to it in a reasonable way. If not, we can experience a whole range of examples of upcoming consequences as it has happened during total post-revolutionary chaos in Muslim countries. That is when the Western countries with all libertarian rules, human rights and complete incomprehension has barged in their radical, ideological-religious world. It seems that the actual conceptual apparatus does not explain anything, because it is based on an imitation and socio-cultural theory. There are two variants of this theory: quite optimistic, which is linked with Stefan Czarnowski's concept of cultural diffusion (particularly to the diffusion of tools as well as cultural ideas) (Czarnowski, 2005) and with pessimistic Max Weber's thought, concerning advantages of religious economic awareness (Weber, 1984). The first one says, that the imitation is creative adaptation through cultural diffusion and every culture produces its own tools to modernize itself, whereas the pessimistic one claims that only some religious churches (only protestants, to be precise) have cultural potential in their religion to create the market and establish capitalism. This "proud", bigger point of view, accepted without deep thinking particularly by American sociology, was internalized into modern theory of development. Therefore, what about the ones who do not fit into the pattern? Well, it turns out that the ones unfitting to capitalistic world will create any form of peripheral capitalism. Creative adaptation is not equivalent to fulfillment and satisfaction with existing situation, what is a characteristic feature of centers. On the contrary, it mostly means that you need to work hard to survive and eventually to achieve, what seemed to be given forever. Worldwide ideas are driven usually by an image of "the golden age". However, "the golden age" is differently viewed by every society. In global centers the idea of "the golden age" is identified with the presence improved by other democratic and market mechanisms. Then 'the idea of golden age' is not necessary, because is replaced by the vitality of their variant of capitalism, meaning liveliness in other words unceasing social change. Therefore, it is not surprising that it translates to human activities and it is driven by current efficiency (according to the main trend of classical political economy of Smith, Ricardo, Marx or Pareto). For the record, efficient effects are a result of specialization, referring to Ricardo. It is characterized by the effects of labour of 'the economic actors' from one country, which can be exchanged for products and services made in another country. Comparative costs of this exchange makes it always profitable for both sides. Moreover, through international trade the efficiency grows and a consumer is provided with a higher quality product than product made in an autarky. Besides, the market becomes richer and the consumption more diversified. But, what about people, who has nothing to offer to an exchange, and hence, they fell out of a supply chain? That is what Ricardo didn't take into consideration. However, Marx claims that these people will make a revolution. We should note that the historical right is on the side of 'the patient economists', not on the side of "the hothead priests" revolutionists. The great change is still not only a creative adaptation, but also the work of people, who don't want it or even are too antiquated for it. The people, who are outside mainstream, are located somewhere on peripheral capitalism. We must take their influence, counteraction and resistance into the account. It's because they live so terrified, in reality, which will once become 'the golden age'. Polish sociologist K. Kelles-Krauz was right when he talked about "right retrospection coups", when idea of new reality replaces the old one in the social awareness of citizens is always similar to the idea of "the golden age" in the meaning of social actors (Kelles-Krauz, 1989).

However, it has to be emphasized (what is an important complement – Poplawski) that ‘the golden age’ is not ‘from this world’. It happens so, when “the golden age” transcends to social reality based on religion. It obviously has impact on present-day life. The best example for that is Buddhism. Referring to Claude Levi-Strauss in “Tristes tropiques” (Levi-Strauss, 2012) a whole social system of India holds in a lack of class strain. Incidentally, it should be also pointed that the promise of “the golden age” is enchanted in reincarnation as well as in Islam, in paradisiac reward for jihad (or Gehennah (Hell) as penalty) or in Christian heaven. Nevertheless, Max Weber brought it to an individual, mundane reward for *Wetablehnende Askese* for protestants, particularly calvinists and puritans (Weber, 2001). The new reality is unknown and hence, it is usually terrifying and insecure, so... it’s worse. Referring to well-known Weber’s proverb, we must say clearly that the new reality demands participating in a market and determines new roles but just mentioned roles are generally secondary and hardly ensure “any market chances for accomplishment”. Well then, so where can we find “cultural optimism”? If there is a lack of it during the life of one generation, then it’s no wonder that cultural pessimism makes havoc (devastation). I mean by that doubts, which can eventually lead to permanent conflict. That is making a situation of ‘the historical actors’ worse and worse and it crosses out their market chances. Let’s have a look at Russia. Russian question “*Wsio normal’no?*” (“Is everything normal?”), when you meet somebody, suggests that usually is abnormally. That a lack of success and normality is a common situation. Such humble attitude it is that American “*Is everything OK?*” sounds even arrogant. Because “OK!” leaves no doubt, when Russian phrase implies dealing with disadvantage of external reality over our potential. Life (or better to say - state and market regulations) creates normal opportunities for market chances or excludes them. Then, we stay out of the market, on its peripherals. From the historic point, market chances conditioned actors in peripheral capitalism. That means, they are marginalized or even excluded. There has never been a stage, described with “*Wsio normal’no?*”. Furthermore, they are not promised with a straight way to welfare. They drift away somewhere, losing their opportunity to develop (Popławski, 1994). Political meanders has also impact on shape of civil society and more general – on democracy in the state of “transition”. According to Samuel Huntington “The third stage of democracy”, the peripheral state constantly reforms itself, adopting and practising democratic rules (Huntington, 2009). It is an unstable element in turbulent surrounding. “Let’s sway, like a shaky boat on waves” – wrote Rainer Maria Rilke, quoted in Heidegger’s essay “What after a poet in the miserable times?” It is not enough that it sways so strong, but also a boat is unstable and the time is miserable. The turbulent surrounding changes completely the role of ruling elites. They supposed to be national, but have become comprador, hereby international corporations are not willing to do business in contrast to particular state’s business. “The drifting state” creates just a guise of normality and affects faith of society. It is labile in its goals and actions, but also divided into privileged business groups, oligarchy and political coterie. State does not create ‘social welfare’. Just the opposite, it makes ‘schizophrenically’ social conflict, which damages the social foundations and legitimization of their main participants. Such conflict might be provoked to control, like they say, “dampening the water makes fishing easier”. Let’s consider, who takes advantage of ‘the drifting state’? The answer is simple. These social groups, which create sense of schizophrenia, social conflict and hypocrisy. Division into two worlds allows covering up real intentions and benefit some groups of interest, who have bad intentions. They would like to take the advantage of underdevelopment of state, conserving it by ideological splits and media propaganda about “a good state” of economy. Weakness of “the manoeuvring state” is the bigger. The more falsified is reality and manipulated society (rather “mythical” crowd quoting Tocqueville). Development economy spreads around, hiding not only “a bliss” of “the drifting state”, but also dependence on big fishes of today’s world. There is no point in standing against them, because of lack of possibilities and financial assets.

The most common situation concerns taking over the banking system that constitutes “economic bloodstream or nervous system”, which when injured or disordered may cause anxiety leading to historical perturbation. In the past, it was all about military dependence. Nowadays, military dependence is substituted by financial submission, which make societies unable to decide about oneself and give birth to an unbearable lack of ownership. That deepens “drifting of state”, which doesn’t have any possibilities to prevent draining economy by some external forces. Frequently, it falls victim of them and has no more influence. This process is often called transition, whereas in fact, its goal is not to transform, but to subordinate the state and to make it an object, instead of being a subject. It is also about citizens, who are asking why the situation is not normal, like in other countries. For the time being, we can answer that in case of such countries a the course of transition is not similar to more advanced countries in this aspect (e.g. Visegrad countries vs. Ukraine, Serbia or Albania), because they are not in the middle of ‘state drifting’. On the contrary, peripheral states are manoeuvring and drifting with no purpose and no clue, how to get welfare. Citizens ask: “Is that what we wanted? Does our state fulfil the welfare in comparison of other, most advanced??” And the answer usually is... “no”. They come back to their own concept of “golden age” from the past. They don’t want it, because peripheral state doesn’t satisfy the need of living and feeling well. In the main, we prefer to change it for the one, which fulfils better our expectations. However, there are too many unclear answers to the questions starting with ‘when’. When the state will stabilise our situation? When will it satisfy even the lowest expectations of citizens? Therefore, we can observe this terrible *exodus* in societies, which welcome refugees and believe that the answers to the questions will come soon. But this constitutes also selfish brain draining of elites and entrepreneurs, without whom the transition states cannot make the change purposeful. It can be shown that both types of countries, the welcoming and the sending refugees, will benefit on this migration, because they will equalize levels of their population. Intensification of *exodus* becomes a common answer to the question, which is a result of doubts that the peripheral state would fulfil its obligations. Undermining patriotism, nation and history becomes a picture of torn self-awareness and a scratch on identity of lost units. So, what is the sphere of interest of the state? Well, it is focused on own drifting. That delivers numerous turbulences, making them unable to regroup forces and resources and in that way to eliminate its own weaknesses. The weaknesses of “drifting state” may make it a victim of more powerful states or occasionally, even smaller but better organized ones.

#### **4. THE ROLE OF POST-FORDISM AND LEAN MANAGEMENT IN TRANSITION**

Turbulent economic and political surrounding makes such situations more possible as it weakens ‘drifting states’, which entered retarded to open market economies and are located at the end of capitalist chains, because the rules were established without their influence and are alien and difficult for “newcomers”. Even the ones, which think that they caught up the leaders, belong to a group of suppliers for postfordist-oriented systems of domination. Domination is ownership. Taking over old “socialist” enterprises through quick process of privatisation for relatively low prices only reaffirmed both, domination and adaptation to alien rules. That is a normal situation that “newcomers” had a few advantages compared to old and a well-established “core”. Peripheral capitalism doesn’t deliver a surplus, but, it drains resources reaching that way critical level of reserves. The surplus of goods from suppliers is very limited in comparison to market brand dominator, coming from leading state. Most often, global corporations de facto controls a market and manages suppliers. As a result, the multinational concerns shake the whole economy in a chain of peripheral, postfordist-oriented countries. An addiction has become bigger since the expansion of international corporations, which force suppliers to produce cheap for chain brands. A supplier from peripheral state has to adjust, therefore he has almost no influence.

Lately, a world-shaking tragedy has happened in Bangladesh when the building collapsed where the clothing factory was located. The reason for that was adding new floors in the factory over building capacity to fulfil orders for cheap clothes for chain stores, such that H&M, but also Polish LPP (Reserved, Top Secret, etc.). It turned out that a rise in price of jeans from \$10 to \$12 would be hardly visible for an average consumer. However, a rise in wage of workers from \$1 to \$2 would let feed the workers' families and improve horrible conditions of working. This tragedy, which have swallowed hundreds of human beings, was a result of incredible and cruel greed of not only local entrepreneurs hiring workers, but also multinational corporations. Consumers organizations and "good will" people decided to boycott brands, which ignored demanding some social standards from their suppliers and misuse workers from peripheral states. Another aspect is the whole market of fake products, which gives jobs for people, but deprive market and brand's reputation. Similarly, producing false copies of computer games, films or music pieces makes it more available, but we can treat it as "a revenge" of poor states on international corporations. "The revenge" for increased prices of intellectual property laws which make products less affordable. There are more and more examples of post-fordism expansion and results for subcontractors and quasi colonial dependence on international concerns. In the context of domination over weaker and smaller countries. It's covered by increasing role of banks and huge finance institutions as well as creative industry and monstrous companies from the branch of informative-telecommunication technologies. Networks entwine the world, frequently using social basis and making virtual societies, kind of a communication parasite. Crossing of peripheral world with world of cultural domination may cause "symbolical violence". That was properly noticed by Pierre Bourdieu, who described this mechanism (Bourdieu, 2006). Well, significations change according to the actual lifestyle of social classes. Bourdieu's precursor, Maurice Halbwachs talked about mnemonic social frames and lifestyles of class fractions, which has modified in a progress of social change. Then, how should we call today's lifestyle, which bases on real-virtual relationships as the essence of human relations? To answer that we should take analyze the consequences of postfordism, which occur these types of societies in such a distinct way. Following a development path including a part of human labor is not a hard task, when we take an appropriate cognitive perspective. Theoretical paradigm uses conceptual apparatus for this purpose. Postfordism is a necessary stage of development in modern times to adapt new democracies to change its economies. Word-concepts, such as peripheral capitalism, postfordism, domination, relationships and networks determine a basis of conceptual apparatus. Thereby, showing the reality in its constant movement is possible. Husserl would say that it discovers eidos by rejecting apparent phenomena, signs and details, and when we focus on them, we won't understand the essence (Husserl, 1973). A process is a movement, that is why every static definition, which try to stop the movement to show the essence (or define it as an obviousness) is useless and false by the assumption. It's a sin to project the reality a priori. In other words, before we describe the move, we should dig into its roots, not the other way around. Word-concept does not belong to language, it makes a value-added referring to marketing terminology. Appearing a word-concept is like opening clearance (Heidegger's *aletheia*). A social phenomenon is not only complex, but also saturated with a sense and values. The sense and values are like breathing. Linking the thesis concerning postfordism with analysis of current conjuncture let define clearance, through which emerges the essence of contemporary peripheral capitalism theory. Let us look at the processes, accelerating the reality (Giddens, 2002). Postfordism on the periphery shows up nearby network of subcontractors (suppliers), which are easily replaceable for the other subcontractors, who want to push to a chain of consumption value to get to consumers on the leading markets. In turn, markets become interdependent, but they are also a subject to a kind of gradation, which depends on its importance for the centers. Frequently, this plays a main role, when it comes to entry to a chain of supply, even without possibility of

forming its own identity, such as brand under domination of a country of origin. An ingoing is strongly connected to financing domestic or international capital. Postfordist chains are created by connections called a vertical integration. As for connecting the supplier or even teaching him the system that directs the receiver of his products and holds back the client from choosing the other supplier (or rather dominator). The point is to connect the client to the system. Worldwide companies not only dominate by making a nodes in chains and organizing networks, but also by domination of marketing actions and creation innovations and fields that clients never thought of. In other words, periphery is being a market useful to test and create new trends. Belated, not modern traditional domains of activity are left to local markets, aside the capitalistic chain. Indeed, these fields prejudge the capitalist character, whether it would be central or peripheral. Postfordism also refers to periphery, however, rarely results in an overall change called development. The history of transition in post communism shows us the truth. It's hard to get out of capitalistic peripheral even when postfordist islands appear somewhere between a general underdevelopment. We can observe that dominators leave not modern branches and industries for periphery, such as agriculture, in which postfordism production methods are difficult to achieve. Since an essence of post-fordism are networks and communication as an expression of dominance. For instance, a global product is finally composed of many components, coming from an integrated chain of different suppliers and countries. A final assembly does not bring much added values, as it occurs in brand production in the country of origin or discounters, which have achieved true dominance and administer a whole package of transactions, maintaining the vitality. That is the vitality of capitalism, what is such a great mystery since almost three centuries. Postfordism has gone through so many different stages, nevertheless, the most important one is the last one, strongly connected to lean management. It has introduced new quality into the sphere of capitalistic vitality with the new chances for dominance and new inequalities, revealed as periphery. The most interesting lean management theory was presented by Bowman and Faulkner (Bowman, C and Faulkner, W. 1994). The only drawback of it is a lack of connection with the theory of human labor, closely linked to postfordism. To put it another way, it's impossible to consider this issue without including both theories, because not all the most crucial aspects will be taken into consideration. In the whole history of mankind there hasn't been invented more efficient work system than postfordism. However, it is true only if we take to the account the efficiency of management revolution, which has transformed a whole global work system in post- capitalism. What I mean by that is cutting costs by using lean management, because it has created the possible transition of periphery into capitalistic, developed core. It is worth to realize it to avoid unnecessary admiration for amazing, recent development of capitalism. A lack of hope that is reaching the dominators is rescued just by demographical weakness of the global centers. Rarely, the other issue is noticed that few possess so much, when millions of people have completely nothing... Adaptation to postfordist modes of production for peripheral economies of emerging market is conditioned by their acceptance of role of being "suppliers" country in a whole period of transition. A simple way to social welfare economy does not exists, sometimes is really complicated and not secure e.g. in post-soviet Ukraine, Moldova, Georgia or in post-Yugoslavian Bosnia, Macedonia, Montenegro, Albania and Kosovo. We can assume that "suppliers" countries are in the middle of transition of the human labor to global level. Nonetheless, their role is lagging by one stage, by "a nexus in a production chain". That is why companies of dominant countries are skimming the cream off the top of the cake, instead of producers and firms from dominated, peripheral countries. The difference of market potential among these corporations and whole countries is significant, e.g. Poland, the country quite big in the EU, is ranked only 16 taken together in the classification with global firms. Their position is rather "battling of a place in the queue" of the previous period. Just like in the times of scarcity, when the most cunning won, but at last, there is not enough even for the smartest.

Even they don't get anything, because the dominators are the ones, who control the rules of the game. The great example of that is the effort of citizens of Poland – the country of everlasting transition. In Poland, population has acquired so many skills and adaptive cleverness to changing, turbulent conditions. However, people are poorly rewarded for that and are constantly left behind, meeting more and more requirements to fulfill. I have called this attitude as “resourcefulness, which has given birth to entrepreneurship” (Popławski, T. ,1997: ch. VII) It's hard not to claim that lean management was introduced to the whole population. “Slimming off” production process, bankruptcy of companies, meeting demands of supply chain, privileges for foreign capital entering the market at cost of own entrepreneurs, exploitation of workers, providing educated for free and excellent workforce, being drained by emigration, working in favor of dominating countries, subcontracting, living in the environment of permanent cost reduction, outsourcing, constant process of education reforms, low wages, automatization, global products, innovative and modern technologies, new working class isn't it lean management? When we add to this, high quality of work and production for low wages, isn't it worth rewarding? Wages in the car production industries for VW in factories localized in Slovakia are no more than ¼ of those in Germany. Identical situation is in the cases of Fiat or Opel. Subcontractors are cheap, but they offer high quality of products comparable with the level of Western European workers (the best in the production network of some brands, like in the case of Opel in Gliwice, Poland and Fiat in Tychy, Poland, but also Skoda in Mlada Boleslav, Czech Republic or PSA and Toyota in factory in Kolin, Czech Republic). It's needed to add, that these investments are subsidized by governments (frequently about with 50 000 Euros for one place of job) and by special reduction of taxes for investors (mostly for 10 years). Liberal ideologists underline that attracting greenfield investments is a big privilege for the countries hosting them (Popławski, 2013). Certainly, there is an award, but it's not up to the effort and not compensated with possibility of a good life. ‘A decent’ profit of the company is based on disrespectful wages for workforce in Poland. Conditions for opening the market to competitors from the EU are not fair. For instance, surcharges for Polish agriculture equal to ¼ surcharges from UE for their equivalent from other countries is particularly glaring. But, even worse are legal mechanisms referring to privileged – unprivileged social classes and occupational groups, which do not allow “to be out of the woods”. Moreover, these mechanisms blur social sense of justice and measure services of particular socio-occupational groups. Undoubtedly, this is a result of intellectually immature authorities and a comprador role of political elites with their qualities such as incompetence, omission, indolence, vulnerability to corruption and even a lack of empathy for authority-society relation. Treating your own society as a stranger is a consequence of power defined by injustice. It is important to note that role of financial mechanisms is becoming bigger and bigger. A very good example of that is indebtedness in foreign currencies, mostly in Swiss francs. Hereby, “a bloodstream” of economy goes into someone else's hands. The hands, which are not sensitive to social needs. The hands, which do a true “slimming off” the living chances of the social actors in dependent economies. Classified as the richest countries in the world, Luxembourg and Switzerland gain a lot on financial speculation and tax evasion, where the money plays the main role - on the one hand, but usury and speculation – from the other. It is not a simple and honest profit are important in this game among modern institutions of modern market. World's financial system generates great inequalities. The history was, after all, the history of kings, but the kings quite heavily indebted to the Templars and hence, to the Rothschild family. Underpaid military, not rarely, betrayed and offered their services to an enemy, if he paid more It is similar to underpaid workers, which were drained on wages by lean management. A sensible authority learns not to give away the most valuable resources, which are social actors. Their value is now higher given an international dimension, while before they were valued only for local markets. Transition management breaks with planning and implementation model and policies aimed at achieving

particular outcomes, based on different philosophy, this one of transition management, which define in the bottom. Rotmans and Kemp from Maastricht resumed this complexity of transition by the concept of: "Transition management...(which TP.) is a form of process management against a set of goals set by society, whose problem solving capabilities are mobilized and translated into a transition program, which is legitimized through the political process" (Rotmans, Kemp, 2003:17). The key elements of their concept of transition management are:

- long-term thinking (at least 25 years) as a framework for shaping short-term policy
- thinking in terms of more than one domain (multi-domain)
- different actors (multi-actor)
- different scale levels (multi-level); how developments at one level with one type of actors gel with developments in other domains;
- the focus on learning and a special learning philosophy (learning-by-doing and doing-by-learning), an orientation towards system innovation.

These proposals are very important to resume period of transition in East European societies. The difference concerns level and quality of management of transition process in each country. Post-fordism is, in my mind, the main element of this complex process of transition management during last quarter century. The quality of transition management decides about its effectiveness and in effect – about success of transition to post-fordism as the mode of production and cooperation between economy of any country of transition and its surrounding. Next goal and task is to transform after the period of experience "the country of enterprises-suppliers" into a process of lean management ("slimming from the costs" of global corporations) and in international chains is to create own brands and firms to functioning at the international level as independent producers. The management of transition concentrated only at the factor GDP should not be crucial for any transition society. The main goal of development is to create better and better conditions to increase position of country in transition in 27 factors of Human Development Index (HDI), which measures also social effects of development. Model of economic autonomy and ownership of law to development implementing at the base of Polish, Slovak, Ukrainian, Serbian economic mentality and identity is crucial for the future. An implementation depends on the force of state against global players – domination countries and rules which privileged its corporations (Dror, 2006). Yecheckel Dror persuades in his report for Rome Club about "Global Governance", that this force is rather dim. Post-fordism reinforce this weaknesses if these states are according to be involved into the policy reinforcing unprivileged situation its own enterprises and crucial sectors (army, public demands) for it. If it is only a transitive stage of modernization as well as technological, organizational and market change of firms from these states by participation in international chains, it is natural stage of modernization and organizational experience, which must be reinforce by national policy and economic rules more and more effective for own economic sector. Polish reports from Center of Eastern Studies confirms (Popławski, 2016) the most significant role of firms from Visegrad countries (particularly Polish) as a suppliers into a whole of German economy, but Germany is most important exporter of merchandises in the world. The main role into this form of post-fordist relations in the world plays Chinese enterprises, but more and more important is the role of suppliers from East European countries. That create completely new situation for governments to answer to the question, if this position is sufficient. It particularly considers state's influence in sectors, firms and services, public, mostly dependent on state policy and rules or established by states (BTV tax, import-export taxes, labor force, army, security, communal, services and administration, public expenses as well as energy, ecology, forest, strategic innovation sectors etc.). Some regulations were introduced by the dominant countries pressed by workers unions, e.g. minimum wage (consider truck drivers, building industry



workers particularly). These regulations were introduced under motto fighting dishonest external competition, because they work for cheaper salaries than the workers from their countries. In fact, it is direct intervention into financial situation of external entrepreneurs and deep change of rules governing their enterprises. This same may be reverse situation, when workers from German owners in a international transport, car branches or discount chains located in these less advanced countries will demand equal (four time higher) salaries to workers in this same factories in Germany or in France.

## **5. AGAINST OF DEPENDENCE OF NATIONAL ECONOMY - MODIFICATIONS OF POST-FORDIST MODEL OF TRANSITION**

There are some other factors than transition complex strategy – individual entrepreneurship, resourcefulness of population, features of labor force (level of education, skills, economic mentality etc.). It is worth pointing out that a Polish migrant with all his skills gained in his motherland, becomes a priceless and wanted asset for capitalist chains. It's because Poland has completely different social and economic structure, a bit belated which demands a multiplication of efforts in order to survive (so called "comprehensive resourcefulness"). Thence, European and American market absorbed such an enormous amount (almost 2 millions) of Polish migrants during the transition, which was a significant part of Polish working population. The situation is even worse at the labor market of small countries as in case of Baltic countries, for example about 0.5 million Lithuanians left to work abroad, that is about ¼ of population capable to work, but in Latvia it is quite similar. The same situation happened in small countries of Balkan region as Bosnia, Montenegro, Macedonia, Albania or Serbia. Such a huge "loss of blood" is irreplaceable, but it's a result of inequality of market chances and a living chance of a worker (Weber, 2002). Resourcefulness transforms into entrepreneurship, however, only few would notice that more and more often it builds creativity, which is a basis of innovation (Schumpeter). You cannot learn innovation, so such a big slimming off the entrepreneurs from imitative countries becomes a social fact, which in turn multiplies economic losses, such as ruining the pension system, exogenous development, imbalance of the generational bonds, population crisis and misses the chance to go "out of the woods". Nonetheless, foreign countries benefit from the whole inventiveness. E. Stiglitz, in his Nobel's Prize book "Globalization and Its Discontents" in important from our point of view subchapter "Countries in the process of outgoing from communism" (Stiglitz, 2004), criticizes too fast and inadequate transition of this countries, especially in the economic field. However, he does understates influence of historic decisions to the contemporary. The most importantly he concerned the role of state force into introduced just 100 years ago (or in some countries after II World War) by violence the collectivization of agriculture, which damaged peasant resourcefulness. He stresses the role of a Chinese farmer, explaining not only the gap between Beijing and Moscow in adaptation to the modern reality of global economy, but also actual force of Polish food industry at the international market. Whereas Jeffrey D. Sachs praises the results of shock therapy, especially for China (Sachs 2006, 1994), not to mention self-praise of his Polish follower, Leszek Balcerowicz (Balcerowicz, 1995). The transition shock for development of Poland and its results, the worst defeat was built on an assumption that "capital has no nationality". Just the opposite way, the capital knows always nationality, as well as rules individual property and ownership providing economic (and in consequence - social) domination of one nation over another. The historically-conditioned economic mentality maybe also an important factor. The most significant historical factor in my mind comes from the consequences of collectivization in agriculture, particularly in the post-Soviet space. These differences are impossible to make up, even during the life of two generations. Fight against collectivization cost Poland hundreds of lives of brave people, who never agreed to live in kolkhozes and only in Poland a process of collectivization agriculture could not be conducted.

On the contrary, in the Soviet reality millions starved to death, unsuited to market conditions are visible to this day in Eastern Europe. More significant consequence up nowadays is that the class of workers from kolkhozes, which replaced the peasant class in rural areas totally lost market mentality and neglected any form of entrepreneurship. Total influence of authoritarian state for citizen have learned helplessness in the place of resourcefulness and entrepreneurship. The main difference among societies leaving from state socialism was the stage of authoritarianism of state and its influence for life of citizen. In Poland that was very weak, but in Soviet Union, DDR or Bulgaria created a form of "learned helpfulness" (Osiatyński, 1996). The new state policy introduced by states of Visegrad, supporting domestic firms and national interests, taking advantage of historically conditioned national features of entrepreneurship (and – in my mind – also on resourcefulness), resisting oligarchic model of development (and its discontents) has become great tool of resistance and counteraction from states of old "core" EU, particularly with Germany as a hegemon. An uniqueness of my proposal consists of much wider explanation. The actual model of economic transition based on simply model of post-fordist integration (chains and dependences) has been exhausted and it is reasonable to replace it by more autonomic model of modernization according to interest of national companies and more active national policy against post-fordist colonization and also against of process of liberal change, which is not in favor of national interests. The social justice and development of national economy in the interest of citizens in the country of transition are the final goals of the modernization. The unexpected effect of implementing this process to the national economy is mostly an introduction elements of state-providence model, rising salaries of citizens and balancing budget. Liberal ideology of colonization by domination of international companies over small national state is changing into historic politics. Oligarchic models of development organized around an ideological vision of "golden socialist age", which had supported birth of powerful oligarchic ownership is not effective economically and socially. In some countries, where it had been introduced, it extended social injustice, strengthened inequalities and promoted underdevelopment.

#### LITERATURE:

1. Balcerowicz, L. 1995. *Wolność i rozwój* (Liberty and Development), Warszawa: PWE , p. 68-80
2. Bourdieu, P. 2006 *Dystynkcja. Społeczna krytyka władzy sądzienia* (fr. Distinction. Critique sociale du jugement), Warszawa: Scholar,
3. Bowman, C and Faulkner, W. 1994. *Strategia konkurencji* (eng. Strategy of Competition), Warszawa: Gebethner i Sk-a
4. Czarnowski, S. 2005. *Kultura* (eng. Culture), Warszawa: Wydawnictwo Akademiczne „Żak”
5. Dror, Y. 2006. *Zdolność do rządzenia* (eng. Capacity to Governance), WSAP, Białystok (Rome Club Report)
6. Giddens, A. 2002. *Nowoczesność i tożsamość* (eng. Modernity and Identity), Warszawa: PWN, p.75, p.256
7. Heidegger, M. 1977. *Budować, mieszkać, myśleć* (eng. To build, to live, to think), Warszawa: Czytelnik, pp.168-170
8. Huntington, S.P. 2009. *Trzecia fala demokratyzacji* (eng. The Third Wave of Democratisation), , Warszawa: PWN
9. Husserl, E. 1973. *The Idea of Phenomenology*, The Hague: Martinus Nijhoff
10. Kelles-Krauz, K. 1989. *Naród i historia: wybór pism* (eng. Nation and History. Writings), Warszawa: PIW
11. Levi-Strauss, C. 2012. *Smutek tropików* (fr. Tristes tropiques) Warszawa: Aletheia
12. Modzelewski, K. 2013. *Zajeździemy kobyłę historii* , Warszawa: Wyd. Iskry

13. Osiatyński, W. 1996. „*Odrodzenie społeczeństwa obywatelskiego*” (eng. Renaissance of Civil Society) in: [online] Available at: <http://archiwum.wiz.pl/1996/96094100.asp> [15.07.2017]
14. Popławski, K. 2016. *Rola Europy Środkowej w gospodarce Niemiec. Konsekwencje polityczne (The Role of Middle Europe. Political consequences)*, Raport OSW, , Warszawa: Wyd. Ośrodek Studiów Wschodnich, p. 60-62
15. Popławski, K. 2013. *W pogoni za globalizacją. Niemieckie relacje gospodarcze z krajami BRIC, (eng. Chasing Globalization. German Relationships from BRIC Countries)*, Raport OSW, Warszawa: Wyd. Ośrodek Studiów Wschodnich, p. 50-56
16. Popławski, T. 1997. *Peryferyjność i społeczeństwo. Dylematy przełomu w Europie (eng. Peripherism and Society. The Dilemmas of Breakthrough in Europe)*, Białystok: Wyd. FEŚiZN, chapter VI
17. Popławski, T. 1994. *Oblicza peryferyjności (eng. Images of Peripheries)* , Białystok: Wyd.FUW, pp. 10-14
18. Rotmans, J. and Kemp, R. 2003. *Improving Information for Policy Makers Managing Societal Transitions: Dilemmas and Uncertainties: The Dutch energy case-study*, OECD Workshop on the Benefits of Climate Policy, Maastricht: MERIT, p. 9-10
19. Sachs, J. 2006. *The End of Poverty. Economic Possibilities of Our Time*, New York: Penguin Books, , [Preface to 2015 Edition],
20. Sachs, J. 1994. *Poland's Jump to Market Economy*, [online] Available at: Kindle Edition [02.06.1994]
21. Stiglitz, J., 2004. *Globalizacja (eng. Globalization)*, Warszawa: PWN,
22. Weber, M. 1984. *Szkice z socjologii religii (ger. Gesammelte Aufsätze zur Religionsoziologie)*, Kraków: Książka i Wiedza
23. Weber, M. 2002. *Gospodarka i społeczeństwo (eng. Economy and Society)*, PWN, Warszawa \* Article supported by Polish Ministry of Higher Education funds S/WZ/2/2017

# **SIMULATION OF THE INTEREST ON SAVINGS IMPACT ON THE CONSTRUCTION COMPANY VALUE DURING THE ECONOMIC CRISIS PERIOD**

**Katerina Bozikova**

*Brno University of Technology, Faculty of Civil Engineering, Czech Republic  
kacasimackova@gmail.com*

**Tomas Hanak**

*Brno University of Technology, Faculty of Civil Engineering, Czech Republic  
hanak.t@fce.vutbr.cz*

## **ABSTRACT**

*This paper deals with the simulation of interest on savings impact on the construction company value in the economic crisis environment when any measure that may help the company to survive on the market or even improve its value is welcome. A substantive value valuation method was applied to assess the construction company value for the purpose of this research and simulation was carried out to analyse the impact of the interest on different amount of savings. A substantive value valuation method took into account both the reproduction cost and accounting values. Furthermore, different types of savings were considered, i.e. saved financial resources on (1) a term account without commitment and (2) with 1-year commitment. These two variants were compared with the valuation of the company in real time (zero variant). Savings were achieved through year-on-year decrease in inventory since decreasing the inventory level is one of the first decisions a company makes during economic crisis. Real construction company operating on the Czech construction market was selected as a subject of analysis for the case study. Data shows considerable deviations in terms of company value during the economic crisis (2008- 2015). Furthermore, results have revealed that the analysed interest on savings impact on the construction company value is minimal. However, the results of the article have also indicated that the crisis management factor is of a considerable importance.*

**Keywords:** *Construction company, interest, inventory, savings, value*

## **1. INTRODUCTION**

Companies face several threats during the economic crisis period. They have to cope with the new market conditions which they are forced to adapt. Significant decrease in the number of active companies [1] is well documented as well as unemployment due to crisis that may be heterogeneous across countries and population groups [2]. In such situation, any measure that may help the company to survive on the market or even improve its value is welcome. Business management in the economic crisis period means good planning and careful managing the corporate finance, which is dealt with by the crisis management. Decrease in inventory stock and increase in turnover becomes one of the first crisis management responses to the situation emerged. Construction industry is a field with specific features such as planned and customized activities. Particularity of construction companies could, in some cases, become an important advantage in managing corporate finance by the crisis management. This paper therefore aims at analysing the impact of interest on savings on a construction company value in the economic crisis period. These savings can be achieved e.g. by reducing stock levels in the storehouse, as large amount of money is deposited in them. These funds can be invested so the method and amount of funds invested can also influence the final value of the company under certain circumstances. On the contrary, the economic situation of the company provides a framework for the crisis management possibilities and for the extent of economic crisis potential impact on

the construction company. The paper is structured as follows: firstly, research background was presented, secondly, the methodology used for the purpose of this research was explained, thirdly, a case study on an existing construction company was processed and analysed. Finally, conclusions and future research directions were outlined.

## 2. LITERATURE REVIEW

Company finance can be controlled with regards to several aspects. Employees and stock turnover can be described as the basic ones. Capital structure is also influenced by management of both receivables and liabilities (i.e. retention fee, see [3]) and overheads management [4, 5]. The knowledge of structure and amount of individual company costs (in time) is an inevitable part of the right decision-making process of the management. Lack of information can lead to a competitive disadvantage [6]. Drury [7] claims that: 'The first step in material planning and checking is the definition of the optimal stock level. This statement proves to be right especially during the economic crisis period and the knowledge of minimal inventory becomes much more important for the company in problems. Correct cost estimate directly influences business performance and efficiency as the overvaluing can cause business and goodwill loss on the market, and vice-versa, undervaluing can cause financial loss for the company [8]. Crisis management usually minimizes the impact of the economic crisis (on a construction company) by reducing number of employees and amount of inventory. Employment work relationships are replaced by contracts for carrying out specific projects (subcontracts). The decrease in the inventory level, in other words the increase in the turnover, increases available corporate capital. The company capital structure quickly reflects both these changes. Gradual reduction of inventory is quite common during the crisis planning, however the possibility to save and profit from these resources (as one of additional tools of crisis management) has not been considered. The 'on-demand' principle is a typical feature of the construction industry, which could represent a certain advantage for the crisis management during risk planning and gives an opportunity to apply less traditional methods of management. Determining the company value means to provide an estimate. There are three basic types of valuation approaches used nowadays: Yield Approach, Cost Approach and Market Approach. An appropriate type of valuation is applied based on specifics of a construction company, its life cycle and reasons for defining its value. Mařík [9] recommends to value a company using all three basic approaches and to determine the resulting value based on a synthesis of the obtained results. In some cases, however, it is not possible. Determining a company value is not an objective feature, so it is not possible to determine a uniform algorithm for its calculation [10]. The valuation process follows the set of International and European Valuation Standards [11] defining values and general rules. These Standards are not mandatory, they represent a general set of internationally recognized recommendations and they deal especially with property valuation (the business valuation is ancillary). Damodaran is a recognized expert on business valuation. He has dealt for a long time in detail with specific features and negative impact of business valuation during individual phases of its life cycle and adverse economic periods [12].

In some cases, it is necessary to analyse and value each property component of the company applying the Cost Approach. The suitability of the selected property valuation approach depends on the approach to valuation of each component itself [10, 13, 14, 15, 16]:

- Book value valuation (answering the question: How much did the assets cost? It is based on a principle of historical prices. It is the less accurate valuation);
- Liquidation value valuation (it is based on defining the value of company assets at a certain date assuming the company is going to close its business);
- Substantive value valuation (the basis of the approach is the reproduction of purchasing price of the same or similar property reduced by a real valuation of all liabilities and receivables to the date of valuation assuming that the company continues its business).

### 3. METHODOLOGY

The methodology used for the purpose of this research consists of several steps. Firstly, real financial data representing a recognized Czech construction company was collected. These data represented financial statements for individual years for (2008 - 2015) period. The most important information obtained from the accompanying documents of the financial statements was about receivables overdue. All data from the balance sheet was significant for the calculation, however, inventories values were the most important (to determine the year-on-year changes in these current assets – a decrease or an increase), and from the part of the profit and loss statements, the information on the depreciation value of long-term tangible and intangible fixed assets was also important. There is a presumption that if the company management takes in account the impact of the economic crisis that usually affects construction companies with a time delay (especially due to ‘on-demand principle’) and consciously saves certain funds as a support crisis management tool, it could have a significant positive impact on the value of the company capital. A substantive value valuation method was applied in order to achieve the established aims. The reason for selecting this method was its suitability for determining the company asset value, and the fact that it does not account for a lot of "unclear" (for example prediction) data as is the case of the Yield Approach. Property valuation was divided according to what principles and assumptions are used for the individual components valuation. This valuation considers permanent existence of the company. Collected data underwent the process of simulation to achieve required results. Savings and subsequent interest were expected as well as year-on-year decrease in certain funds. The accounting reports (Balance sheet and Income statement in CZK; 1 EUR = 25.430 CZK on 19 September 2018) were edited by standard accounting operations based on the simulation to show the difference in comparison with the current value of the construction company. In particular, it meant:

- Interest on the saved funds (once a year - invariably at the end of the year) and crediting of funds to the bank account (i.e. to the value on the balance sheet item "Accounts in banks" the interest-bearing amount was added (there was annual interest, however the savings increased only yearly when the company actually decreased stock levels) over a certain period -> depending on which year the value of the company was determined for 2010, 2013 or 2015. This affected the asset part of the balance sheet;
- The changes described in the previous paragraph also reflected in the liability part, i.e. in the economic result;
- Decrease in value of overdue receivables (Determination of overdue receivables maturity scale with the allocation of the price reduction coefficient. Overdue receivables ranged from 0 to > 540 days and the coefficients ranged from 0.1 to 1.0, i.e. the longer the receivables maturity was overdue, the lower the coefficient).

Interest on different amount of savings using the term account without commitment and with 1-year commitment for the 2008-2015 period was simulated. The considered options were as follows:

- Option 1: valuation of a construction company in real time,
- Option 2: valuation of a construction company with a year-on-year decrease in the inventory (0.5%; 1.0%; 3.0%; 5.0%; 10.0%) and interest on the saved financial resources on a term account without commitment,
- Option 3: valuation of a construction company with a year-on-year decrease in the inventory (0.5%; 1.0%; 3.0%; 5.0%; 10.0%) and interest on the saved financial resources on a term account with 1-year commitment.

Determining the company value in 2010, 2013 and 2015 reflected all simulation options. The time frame was set to describe the above mentioned construction company operating during the

economic crisis. The economic crisis began to manifest itself in 2008. It can be assumed that if a company realized emergence of the economic crisis in 2008, it set a crisis management plan, both short-term and long-term, and started to save financial resources already from the beginning of 2009 to get interest on them from the beginning of 2010. In fact, the company kept reducing inventory during the economic crisis. The substantive cost method was selected to define the value of a construction company ( $V_0$ ) based on the above mentioned facts. This method applied both the reproduction cost and the accounting values. This way of valuation distinguishes the gross value (a value of re-purchasing of company assets) and the net value (an equity value) [9, 10, 16]. The components were valued under the following conditions to the date of valuation, which was the last day of the year:

- The company saved certain funds for 1 year and got interest on them;
- The interest was credited to its bank account once a year (on December 31, 20XX);
- There was a plan of annual savings during the years of real inventory decrease (% of year-on-year inventory decrease);
- There was not a plan of annual savings during the years of the company inventory increase;
- The company could withdraw the resources at the end of the year or leave them, it could also add other saved funds;
- The company continued its business.

The company value was determined according to the following formulas [9, 10, 12, 13, 14, 15, 16]:

$$V_t = A_t - P_t \quad (1)$$

Where:  $V_t$  = intrinsic value of company determined by the substantive/equity method (net value);  $A_t$  = total assets (gross value);  $P_t$  = debts

$$A_t = R_C - O \quad (2)$$

Where:  $A_t$  = gross value;  $R_C$  = value of the company assets in reproduction prices;  $O$  = property wear and tear

$$R_C = DHM_t + DNM_t + DFM_t + Z_t + P_{Pt} + KFM_t \quad (3)$$

Where:  $DHM_t$  = value of tangible fixed assets;  $DNM_t$  = value of intangible fixed assets;  $DFM_t$  = value of financial assets;  $Z_t$  = value of inventory;  $P_{Pt}$  = value of re-evaluated receivables (reducing the receivables to reflect the risk of non-payment and time factor [10]);  $KFM_t$  = value of short-term financial assets

$$KFN_t = M_t + UB_t \quad (4)$$

Where:  $M_t$  = volume of money;  $UB_t$  = funds on bank accounts in year  $t$  (in case of simulation increased by annual savings  $t-1$  and interest using the actual interest rates on term account in year  $t$  according to the Czech National Bank [17])

$$P_t = S_t + OP_t \quad (5)$$

Where:  $S_t$  = value of foreign resources including reserves, long-term and short-term liabilities);  $OP_t$  = other liabilities.

## 4. CASE STUDY

### 4.1. Input data

The data used in the calculation was the real data of one of the largest construction companies operating on the Czech market for more than 20 years. This company performs all kinds of construction works in the sectors of transport and civil engineering. The average number of employees in the company was growing up during the operation on the Czech market till the period of economic crisis in the Czech Republic. This resulted in a decrease in the number of employees. The impact of the economic crisis on company activities was also reflected in the monitored period (2008-2015) on a lower number of contracts, which influenced the reduction of outputs. Decrease both in the output and average number of employees in the monitored period is shown in Figure 1. The primary input data used for the analysis and simulation is shown in Table 1.

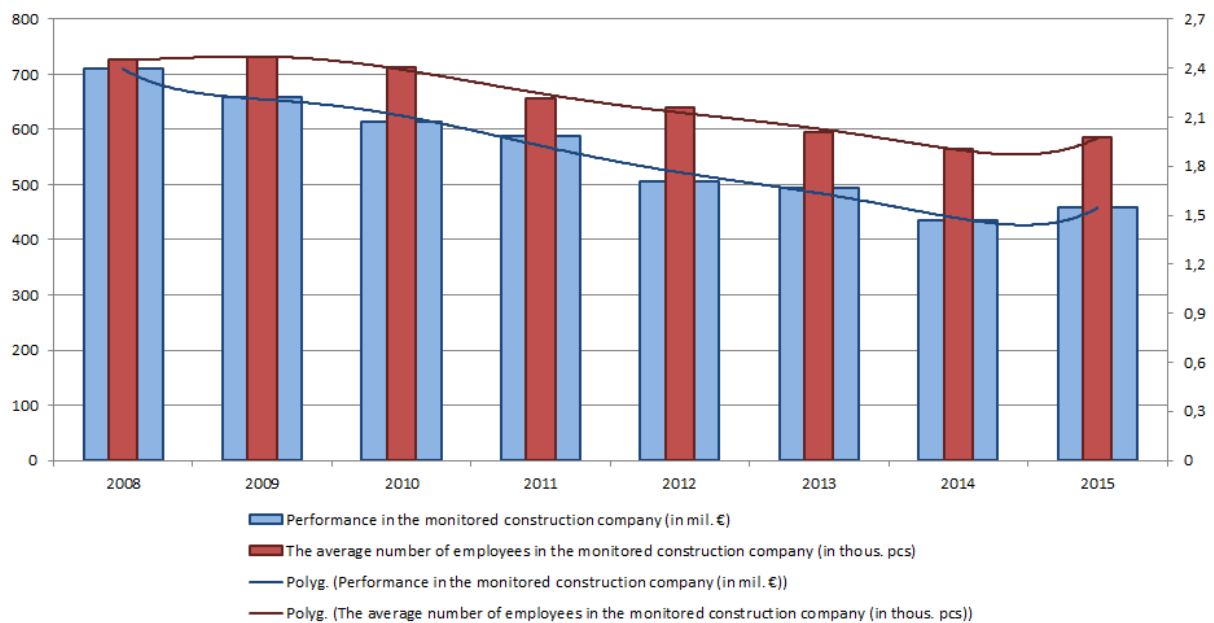

Figure 1: Development of the average number of employees and the performance of the monitored construction company in the 2008-2015 period (authors' own work)

Table 1: Primary input data of a real state (in thous. €) (authors' work based on the financial statement)

Year	2010	2013	2015
O	8,125.088	5,446.166	6,451.947
DHMt	34,970.743	32,931.184	33,905.781
DNMt	0.000	0.000	0.000
DFMt	17,469.681	23,782.501	16,900.865
Zt	18,198.860	13,001.927	5,860.440
PPt	506,305.902	342,323.331	525,197.322
Mt	100.393	68.266	74.243
Ubt	92,496.775	132,985.608	107,400.079
St	222,397.208	245,174.636	335,009.320
OPt	35,206.685	8,362.525	8,622.493



The economic crisis came to the Czech Republic in 2008; however, as the construction market functions on the principle of forwarded contracts, this situation was reflected with some delay in the economic results of companies. Therefore, this market information was also taken into account in the approach to the simulation setting. The first data entering the calculations was from 2008, because it was assumed that after the outbreak of the economic crisis in the Czech Republic, the company would include the reduction of the stock level higher than necessary in its plan and would put interest on this higher (than plan) savings. Therefore, if the plan was applied in 2008, these savings could be added to the account at the end of 2009 and interest could be earned on them. At the end of the year, the company could choose whether to withdraw the interest-earned money and use it for its activities, or to keep it on the account, add another year savings and earn interest on them again. This principle could be repeated again and again. The data of the term account with no commitment and the 1-year commitment used for the analysis and simulation is shown in Table 2. Since the simulation itself is based on the impact of interest-earned savings on the value of the company, the first year for the determination of the company value including simulations, was 2010. It was essential to already have the amount of the interest-earned funds for carrying out the simulation. As the economic crisis just hit the Czech market in 2008, simulation (with the same amount of information) could not have been carried out for the 2008 year. The year 2015 was a year when the economic crisis was already in decline so the valuation for the 2013 year was a convenient completion to a more realistic outcome within the period.

Table 2: Data of the term account without commitment and with 1-year commitment (in %) (Czech National Bank, 2018, [17])

Year	2008	2009	2010	2011	2012	2013	2014	2015
Term account without commitment	0.0220	0.0082	0.0049	0.0055	0.0038	0.0030	0.0028	0.0017
Term account with 1-year commitment	0.0254	0.0158	0.0145	0.0169	0.0182	0.0115	0.0092	0.0078

#### 4.2. Results and discussion

This chapter presents results of company valuation and consequent simulation. Data shows values of the construction company according to the above described options, including timing. In particular, Table 3 shows data for the 2010, 2013 and 2015 years.

Table 3: Company value including impact of interest on savings (authors' own work)

Options of interest on savings	2010		2013		2015	
	VoCC (V <sub>0</sub> ) (in thous. €)	RoV to Option 1 (in %)	VoCC (V <sub>0</sub> ) (in thous. €)	RoV to Option 1 (in %)	VoCC (V <sub>0</sub> ) (in thous. €)	RoV to Option 1 (in %)
Option 1 – real situation	403,813	100.00	286,109	100.00	339,255	100.00
Option 2 – 0.5% WoC	404,045	100.06	286,599	100.17	339,775	100.15
Option 2 – 1.0% WoC	404,277	100.11	287,088	100.34	340,295	100.31
Option 2 – 3.0% WoC	405,205	100.34	289,045	101.03	342,374	100.92
Option 2 – 5.0% WoC	406,132	100.57	291,002	101.71	344,453	101.53
Option 2 – 10.0% WoC	408,451	101.15	295,895	103.42	349,651	103.06
Option 3 – 0.5% WC	404,047	100.06	286,617	100.18	339,800	100.16
Option 3 – 1.0% WC	404,282	100.12	287,125	100.36	340,345	100.32
Option 3 – 3.0% WC	405,218	100.35	289,157	101.07	342,526	100.96
Option 3 – 5.0% WC	406,154	100.58	291,189	101.78	344,706	101.61
Option 3 – 10.0% WC	408,496	101.16	296,268	103.55	350,157	103.21

Note: WoC = without commitment, WC = with 1-year commitment, VoCC = Value of construction company, RoV = Ratio of Value.

The impact of interest on savings on the company value in 2010, 2013 and 2015 (Table 3) oscillated between 0.57% and 1.16%, between 0.17% and 3.55% and between 0.15% and 3.21% for the construction company value respectively. The interest on savings achieved the highest value of 10% of the year-to-year inventory decrease when applying the option with the term account with 1-year commitment. It is possible to say, that during the monitored years of the economic crisis, the company value dramatically dropped from € 403,813,374 (2010) to € 286,109,489 (2013). This decline was due to the delayed impact of the economic crisis on the construction company. As a result of the decline in the volume of construction orders, the company was forced to reduce the number of employees as well as current and fixed assets (mainly inventories). Between 2010 and 2013, stocks level decreased from € 18,188.8 thous. to € 13,001.9 thous. The decline in the value of the company between years is affected by the decline in the short-term receivables and the increase in foreign resources ( $P_{Pt}$  and  $S_t$  in Table 1) reflecting the volume and financial value of the contracts executed. The construction company managed to stabilize and increase its value again between 2013 and 2015. The economic crisis ended at the same time, which could be mutually related. In 2015 there was a large increase in short-term receivables, the added value of executed orders increased and the company also increased the number of employees. This was also reflected in the value of the company, which reached € 339,254,971 in 2015. However, the value of the company was below the 2010 level. This was due to the difference between a larger percentage increase of foreign sources (50.65%) and short-term receivables (3.73%) between 2010 and 2015. The value of the company in 2015 reflected the recession of the economic crisis. Reducing the inventory level is one of the first decisions for a company in the case of economic crisis, which is quickly reflected in the amount of available corporate funds. The construction company, on which this simulation was carried out, also, in reality decreased year-on-year inventory stock levels. Its year-on-year decline was mathematically determined between 2008 and 2015 (in the form of a median) at a level of -31.87%. The selected method for calculating the value of a construction company reflected the change in the efficiency of the stock inventory management. The maximum impact intensity of 3.55% in 2013 reflected, according to our conclusions, the importance of increasing the inventory management efficiency (including the creation and streamlining of savings based on it) for a company in the situation of economically challenging conditions. Although it can be perceived that the impact of the interest-earned savings of the construction company does not have an entirely significant influence on the total value of the company, on the contrary, the calculations in this article have shown that it cannot be underestimated as one factor from a large range of the crisis management options. It can be concluded that earning the interest on the planned financial savings increases the company value and leaves enough possibilities for emergency crisis solutions (in the form of a forced selection). Correct setting of crisis plans and appropriateness of the crisis management decision brings a competitive advantage for the company and increases its value.

## 5. CONCLUSION

The article focuses on the impact of the interest on savings on a construction company and its value during the economic crisis. Based on the above-mentioned results it is possible to conclude, that if the crisis management gradually reduces the inventory level during the economic crisis, it is possible to plan a higher reduction in the volume of inventory systematically in order to achieve savings and subsequently earn interest on a certain amount of funds from the year-to-year inventory decrease. Reducing the inventory level should be one of the first decisions which a company makes during the economic crisis that quickly reflects in its cash flow. The delay of the economic crisis impact on the construction industry sphere and construction companies as well, can be an advantage if the crisis management considers this anomaly in time and includes it into its crisis plans.

Company cannot “lock” funds on bank accounts with higher interest rate and do not have them quickly available during the economic crisis. Based on the results, it is preferable to deposit saved year-on-year funds on a term account with 1-year commitment. If necessary, the company can use the funds after each year or increase the sum and continue in saving. The selected method of company valuation reflects the change in the inventory management. According to the research conclusions, the maximum intensity of the impact 3.55% in 2013 corresponded to the importance to increase efficiency in the inventory management (including efficiency in the savings) of the company operating under difficult conditions. Although it may seem that the impact of the interest on savings is minimal on the entire company value, the results of the research have proved that it is the only factor of the crisis management of a considerable importance. Interest on the planned savings increases the company value and provides possibilities for emergency crisis decisions (necessary selection). A correct plan setting and crisis management decisions provide a competitive advantage to a company and increase its value. When simulating volumes and methods of impact of interest on savings (in % of year-on-year inventory decrease) on the construction company value, a difference in the efficiency of the options was expected. In other words, the results of the simulation (interest on savings) could have significant impact on the amount of the assets of a construction company and, consequently on its value. All this was expected to be more conclusive when evaluating the company. This hypothesis was confirmed. It is preferable to carry out a detailed study on a larger number of samples in terms of a number of the crisis management options and their extent of impact. Further research can focus on identifying mutual influence and impact of crisis management decisions on the final value of a construction company.

**ACKNOWLEDGEMENT:** *This paper has been written with the support of the research grant FAST-S-18-5154 Company costs and tender prices management in the construction sector.*

#### **LITERATURE:**

1. Trasca, D. L. (2015). The Consequences of the Economic Crisis on Small Companies from Romania. *Procedia Economics and Finance*, 23, 1266-1272.
2. Boeri, T., Jimeno, J. F. (2016). Learning from the Great Divergence in Unemployment in Europe. *Labour Economics*, 41, 32-46.
3. Korytářova, J., Puchýř, B., Božíkova, K., Špiroch, M. (2017). Simulation of the Influence of Different Ways of Setting the Restraint on Value of Construction. *Procedia Computer Science*, 121, 630 – 636,
4. Apanavičiene, R., Daugeliene, A. (2011). New Classification of Construction Companies: Overhead Costs Aspect. *Journal of Civil Engineering and Management*, 17(4), 457-466.
5. Leśniak, A., Juszczak, M. (2018). Prediction of Site Overhead Costs with the use of Artificial Neural Network Based Model. *Archives of Civil and Mechanical Engineering*, 18(3), 973-982.
6. Cooper, R., Kaplan, R. S. (1988). Measure Costs Right: Make the Right Decisions, *Harvard Business Review*, 96-103,
7. Drury, C. M. (1992) *Management and Cost Accounting*, e-Book, 1992, p. 45,
8. Niazi, A., Dai, J. S., Balabani, S., Seneviratne, L. (2006). Product Cost Estimation: Technique Classification and Methodology Review. *Journal of Manufacturing Science and Engineering*, 128, 563-575.
9. Mařík, M. (1996). *Oceňování podniků (Value of companies)*, 1<sup>st</sup> ed. Praha: Ekopress, s.r.o., p. 111.
10. Mařík, M. et al. (2011). *Metody oceňování podniku (Methods of company valuation)*, 3<sup>rd</sup> ed. Praha: Ekopress, s.r.o., p. 494.

11. European Valuation Standards. (2016). European Valuation Standards, 8<sup>th</sup> edition, ISBN 978-90-819060-1-2. Retrieved 29 September 2018 from [https://www.ipav.ie/sites/default/files/blue\\_book\\_evs\\_2016.pdf](https://www.ipav.ie/sites/default/files/blue_book_evs_2016.pdf).
12. Damodaran, A. (2010). *The dark side of valuation: valuing young, distressed and complex businesses*, 3<sup>rd</sup> ed. New Jersey: Pearson Education, p. 590.
13. Kislingerová, E. (2001). *Oceňování podniku (The company valuation)*. 2<sup>nd</sup> ed. Praha: C. H. Beck., p. 367.
14. Zima, P. (2016). *Oceňování podniků v právní praxi (Valuation of companies in legal practice)*. Praha: C. H. Beck, 179-182.
15. Tichý, G. E. (1991). *Oceňování podniku (Valuation of companies)*, Praha: Linde Praha a.s., 46-51.
16. Dluhošová, D. et al. (2010). *Finanční řízení a rozhodování podniku (Financial management and company decision-making)*. Praha: EKOPRESS s.r.o., 171-193.
17. Czech National Bank. Database of time series. Retrieved on 20 June 2018 from [http://www.cnb.cz/cnb/STAT.ARADY\\_PKG.VYSTUP?p\\_period=12&p\\_sort=2&p\\_des=50&p\\_sestuid=30168&p\\_uka=11%2C12%2C13%2C14%2C15&p\\_strid=AAABAA&p\\_od=200812&p\\_do=201712&p\\_lang=CS&p\\_format=0&p\\_decsep=%2C](http://www.cnb.cz/cnb/STAT.ARADY_PKG.VYSTUP?p_period=12&p_sort=2&p_des=50&p_sestuid=30168&p_uka=11%2C12%2C13%2C14%2C15&p_strid=AAABAA&p_od=200812&p_do=201712&p_lang=CS&p_format=0&p_decsep=%2C)

## EFFECTIVENESS OF THE REVIEW OF PUBLIC PROCUREMENTS IN SELECTED COUNTRY

**Veronika Linhartova**

*University of Pardubice, Czech Republic  
veronika.linhartova@upce.cz*

**Aneta Machackova**

*University of Pardubice, Czech Republic  
aneta.machackova@student.upce.cz*

### **ABSTRACT**

*Supervision and control of public procurement is a crucial topic as public funds are used on a considerable amount of money with a significant amount of money from public budgets. If the contracting authority favors one of the participants, this will have a negative impact on all the country's inhabitants. These phenomena must be avoided; therefore, the regulation and controls in this area are important and necessary from the point of view of the independent body. In the Czech Republic, this power is placed in the hands of the Office for the Protection of Competition. The aim of the paper is to determine how the contracting authorities react to significant fines imposed by the Office for the Protection of Competition. Also, if the fine imposed worked as a means of modifying the public procurement procedure and if there were new measures or a revision of the existing procedures adopted to avoid repeated violations of the Public Procurement Act. Based on research over the period 2013 to 2014, the effectiveness of the Office for the Protection of Competition supervision is not very high. The inefficiency stems primarily from the unwillingness to identify the responsible person who caused the breach of the law.*

**Keywords:** *Public procurements, Office for the Protection of Competition, review process, Public Procurement Act, Czech Republic*

### **1. INTRODUCTION**

Supervision and control over public procurement is a very critical topic, as public funds are expended on a considerable amount of money in a year with a significant amount of money from public budgets (Halásková & Halásková, 2018). In the Czech Republic, about 10% of the gross domestic product represents public funds spent on public procurement, which in the year 2016 amounted to about CZK 486 billion (Ministry for Regional Development of the Czech Republic, 2017). The purpose of public procurement is above all to ensure the production of a particular good or the provision of a service resulting from public needs or the public interest. The success of the tenderer in obtaining a public procurement is determined by several criteria - mainly depends on the price and quality of the goods and services offered. In the case that, the contracting authority favors one of the parties for its own enrichment, it will have an adverse effect on all the population of the country. For, as already mentioned, public procurement is financed by tax and fees. Such behavior will have a significant impact on the financial part of the contract or on the quality of the purchased goods and services (Soukoupová and Bakoš, 2017; Gavurova, B., Tuček, D., Tkacova, A. and Danko, J., 2018). This problem occurs not only in the Czech Republic but also in other countries of the world. The above-mentioned phenomenon must be avoided in order to prevent its adverse impact on the economic market. Therefore, the necessary regulation and control in this area are important and independent from the point of view of the public authority. In the Czech Republic, this power is placed in the hands of the Office for the Protection of Competition (hereinafter referred to as the "Office").

The review procedure belongs to the part of the procurement procedure, which helps to ensure transparency, equal treatment, proportionality and non-discrimination as enshrined in § 6 of Act No. 134/2016 Coll. on Public Procurement tendering (hereinafter referred to as the "Act"). Supervision of public procurement is the responsibility of the Office, the Supreme Audit Office, the tax authorities and the financial auditors. The Office starts its own initial review procedure when, on the basis of its own investigation, it finds doubts about the acts of the contracting authority and also on the basis of a complaint from an individual or a legal entity. Such a person is obliged to pay a fee of CZK 10,000 for each written application for each contract separately. The fee is non-refundable. The complaint cannot be lodged by a person who could lodge an objection within the prescribed time-limit for the opposition proceedings. The first step in the protection against the wrong procedure of the contracting authority is the opposition procedure, followed by a review procedure and a decommissioning procedure, which may not always occur. The last option is the administrative procedure before the court. Opposition procedure is a statutory control mechanism under § 241 of the Act and provides the potential contractor or tenderer with the opportunity to remedy the unlawful procedure of the contracting authority when awarding a public contract. The reason for the objection is to prove the occurrence or imminent harm. The objection procedure precedes the initiation of the review procedure with the Office and cannot be omitted. In the event that the petitioner opts out the opposition proceedings and submits a petition for review to the Office, his proposal will become invalid and the Office will not deal with it. An exception is the emergence of new facts which were not known within the deadline for objection. Such a fact is the claimant's duty to prove. Objections may be made against any act or omission of the contracting authority, the choice of the type of procurement procedure or the procedure of the contracting entity. Following the unsuccessful acceptance of the objection by the contracting authority is the review procedure within it, the petitioner can turn to the application by submitting a proposal to the Office. With the proposal submitted to the Office, the obligation to deposit a bail of 1% of its bid price in the Office's account. The amount of the deposit must be at least 50 thousand; the upper limit is 10 million crowns. If the bid price cannot be determined, then the deposit is set at CZK 100,000. In order to ensure the protection of the rights, any interested party may bring an ordinary appeal, that is, the decomposition under § 152 of the Code of Administrative Procedure, if it disagrees with the decision already issued by the Office at first instance. The decomposition must comply with the general requirements pursuant to § 37 (2) of the Administrative Procedure Code and must be submitted within 15 days from the date of notification of the decision. The Chairman of the Office has the competence to decide on the appeal based on the proposal submitted by the Board of Appeal. The chairman may, on the basis of the proposal, withdraw, amend or reject the first-instance decision. The Act defines a resolution against which it is inadmissible to file a decomposition. In particular, it is a provision that a) governs the conduct of an administrative procedure, b) a period has been set for the execution of the act, or c) obvious inaccuracies have been corrected unless the decision is corrected. (§ 262 of the Act). If any of the interested parties continue to disagree with the second-instance decision, the party concerned may turn to an action brought before the Regional Court in Brno. In the event that the judgment of the Regional Court will still affect the person concerned abstaining from his rights and will not agree with the conclusions of the court, he may oppose the judgment by filing a cassation complaint to the Supreme Administrative Court. A cassation complaint may also be filed by the Office. The number of judgments issued by the Regional Court in Brno and the Supreme Administrative Court is in favor of the Office with both institutions according to the published statistics of the Office (Ministry for Regional Development of the Czech Republic, 2017). The aim of the paper is to determine the extent to which and how the contracting authorities react to significant fines imposed by the Office for the Protection of Competition. Also, if the fine imposed was a means of changing the way in which public procurement was undertaken and whether new measures

were adopted or a revision of existing procedures so as to avoid repeated violations of the Public Procurement Act.

## 2. MATERIALS AND METHODS

The basis for the research on the efficiency of the public procurement review was the analysis of the fines imposed by the Office for the period from 2013 to 2014. During the reporting period, the Office imposed a fine of 176 on institutions for violation of the Public Procurement Act. Some of the organizations that have committed violations of the abovementioned law have been approached so that, within the framework of the obligations laid down by Act No. 106/1999 Coll. on Free Access to Information, answered four questions about the Sanctions authorized by the Office and the way the measures were taken so as to repeatedly not breach the law. Specifically, fifty organizations (25 subjects for each analyzed year) who were fined more than 50,000 thousand crowns were included. The above-mentioned criterion has been set on the basis of a situation whereby less serious misconduct could be avoided to influence the research that could occur. The structure of the questions asked was as follows:

- Did you identify a person responsible for breach of the Public Procurement Act?
- If so, was the personal responsibility of the employee concerned? In what way?
- If the culprit was not identified, is there a documentation explaining this fact?
- Have measures been taken to prevent a repeat offense? If so, please specify them.

In order to analyze the value of the fines set, a box diagram is used to determine the minimum and maximum values of all data. Those data are also referred to as extremes and the "box" middle part is bounded from the bottom of the 1st quartile and from above by the third quartile. Inside of that box occurs the median value.

## 3. RESULTS

### 3.1. Analysis of the effectiveness of the review in the Czech Republic

In the research carried out, 50 bodies were contacted asking for information on the imposed fine. Relevant responses from addressed entities can be considered as 20 in 2013 and 21 in 2014. As some entities are being sued before the Regional Court in Brno or before the Supreme Administrative Court or criminal proceedings and, until such time as these proceedings are closed, they do not want these entities to provide information on the basis of the law on free access to information. Tab. 1 also does not include organizations that have not responded or replied that they are not considered to be the subject of an obligation to disclose information on the basis of the abovementioned law.

*Table 1: Number of addressed entities by its legal form in 2013 and 2014 (own processing)*

	Number of addresses 2013	Relevant answers 2013	Number of addresses 2014	Relevant answers 2014
<b>a.s., s.r.o.</b>	2	1	2	2
<b>State enterprise</b>	-	-	1	1
<b>Organizational unit of the state</b>	2	2	5	4
<b>Contributory organisation</b>	5	4	3	3
<b>Health insurance</b>	1	0	-	-
<b>College, high school</b>	3	3	2	1
<b>Public Research Institution</b>	-	-	1	1
<b>Bundle of municipalities</b>	-	-	2	0
<b>Municipality</b>	11	9	8	8
<b>Region</b>	1	1	1	1
<b>Total</b>	<b>25</b>	<b>20</b>	<b>25</b>	<b>21</b>

The amount of the fine should be set with regard to the significance of the breach of the law and also proportionate to the size of the organization or the amount of its annual budget. The amount of the fine imposed should reflect the fact and affect the fined entity that should deal with who or what caused the deviation from the law. Provided that the violation was committed by a natural person, he can also assume his personal responsibility according to the degree of fault for the fined facts. The guilty party should also take action, either by introducing new or revising existing internal directives, emphasizing multiple control or simply establishing separate staffing departments involved in the procurement process and more frequent training of these staff to avoid recurring mistakes. This is the only way to say that the control process has been effective. There is a summary of the addressed entities who have not filed a lawsuit before the court or whose proceedings have been finally disposed of in Tab. 2 The report provides information on which of the fined subjects identified the person responsible for the violation and how many of these people are required to pay or otherwise compensate for the damage caused. The last mention is information on the adoption of measures to avoid repetition of the situation.

*Table 2: Summary of adressed entities (own processing)*

<b>Judicial proceedings are not under way (n)</b>	41
<b>responsible person designated</b>	18
<b>% of n</b>	43,90 %
<b>Compensation required</b>	13
<b>% of n</b>	31,71 %
<b>Other measures have been taken</b>	26
<b>% z n</b>	63,41 %

The imposition of a fine as a remedy for certain organizations is not an effective way of preventing non-observance of the law. If the Office imposes a fine on an organizational unit of the state, it is an ineffective remedy, because, as one of the ministry addresses the letter sent with questions about the imposed fine from the Office, the imposed fine is by no means a pity. Acceptance and subsequent payment to the account of the customs office is only a transfer of funds from one account to another State account. The organizational unit does not need to look for a responsible individual or group, change the existing procurement process or take steps to prevent recurrence. The Ministry or other fine-tuning organizational units will raise the budget for the fines paid next year and the resulting loss for this entity is zero. On the other hand, the fine of the organizational unit has certain effects on the state, namely the costs of control and proceedings before the Office, in the case of bringing the action also court costs, costs of external experts and others. The fine imposed on any organizational component of the state is an ineffective remedy. Fines must be avoided by state-owned companies, joint-stock companies, and other legal entities, as they must earn the fine to pay the fine. The fine is usually paid out of the unexpected event or similar, but it will also reduce the potential profit. A similar situation applies to municipalities and towns. By paying the fine, their annual budget will be reduced and funds will not be used for other activities in the public interest. If these entities want to engage in public procurement, it is advisable to have a well-executed contract with an external company that can help them get the contract and, at the same time, seek compensation in the event of a sanction. However, there are some organizations, for example, small municipalities that are unable to draw orders because of the financial and time-consuming nature of the contracts. For these entities, there is a high effort not to violate the law and thus not to impose a fine other than the state's organizational units. A remedy in the form of a fine makes sense if the fined entity is a state enterprise, a legal person or a municipality.



### 3.1.1. Amount of the fine

If the Office finds a non-compliance with the Public Procurement Act, it shall decide to impose a corrective action or a fine on the guilty party. The imposition of a corrective action makes it impossible for the contracting authority to continue the ongoing proceedings or, as a result, the entire award procedure will be canceled. If the Office decides to impose a fine, it means that the contractor or, more often, the sponsor committed an illegal procedure and committed an administrative offense or misdemeanor (according to the current law). The imposed fine has a preventive and repressive function. The purpose of the preventive function is to prevent a violation of the law and the amount of the fine imposed should be determined in the light of the benefits to the lawful offender. On the other hand, the repressive function of the fine should include the impact on society and reflect the degree of seriousness of the fault in the law. The Office, other than the amount of the fine, must also take into account the subjective aspects of the hearing whether it was intentional or negligent, the consequences of the infringement on the economic market and the length of the duration of the act in question. Also, the Office must not forget about the consequences of the fines on the complainant's position on the market and the impact on its profitability. As illustrated by the box graph in Fig. 1, in fifty decisions analyzed, the fines imposed ranged from CZK 50,000 to CZK 8.5 million. The median value is CZK 150,000, the average amount of the fine being CZK 491,600. The so much different average amount of the fine from the median value is primarily caused by three entities whose fine exceeded one million crowns. The largest number of imposed fines is between 70,000 and 200,000 CZK.

Figure 1: Amount of fines imposed (own processing)

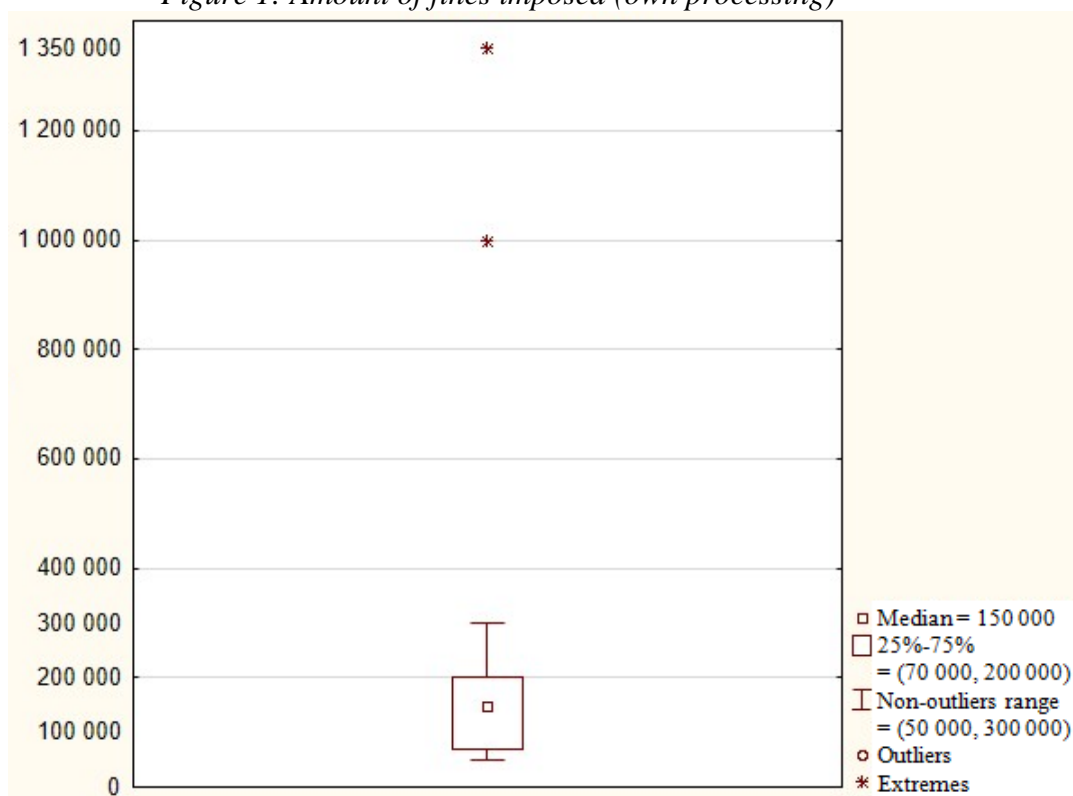

In 2013 and 2014, the Office imposed a fine of more than CZK 300,000 on a small number of subjects, only 3 subjects - the health insurance company, the ministry, and the joint-stock company - had finalized fines. The amount of the fines imposed on the first two entities is shown in the graph as an extreme, for reasons of clarity of the chart, the fine of CZK 8.5 million is not mentioned in the joint stock company.

### 3.1.2. Analysis of the effectiveness of the activities of the Office

The effectiveness assessment of the Office is aimed at the period 2012 to 2016. The Office has several missions. Mainly, monitoring and advising on public support, overseeing spending on public procurement, and thus achieving greater transparency and ensuring the functioning of the economic market in accordance with competition rules to avoid cartels or abuse of dominant power vis-à-vis competitors or residents. The total cost of covering all the agenda and operation of the Office is about 200 million crowns, only about one fifth higher in 2012, worth about 242 million crowns. This is state expenditure and the bulk of it (92% in 2016) is for current expenditure, with the largest item being salaries and related expenses. Other funds are invested in capital expenditures (8% for 2016), mainly for the acquisition of tangible and intangible fixed assets. Tab. 3 illustrates the evolution of the above-mentioned costs of the Office and the level of salaries for 2012-2016.

*Table 3: Expenditure of the Office for the Protection of Competition, in thous. CZK (own processing based on Office for the Protection of Competition (2018a))*

	Total costs of the Office	Of which salaries and related expenditure
2016	203 475	138 697
2015	197 159	142 149
2014	202 268	123 260
2013	240 745	112 843
2012	241 785	101 173

"Decision-making in public administration is an important and integral part of the process of social management. It is characterized by certain stability or regularity, a considerable degree of legal regulation and possibilities of coercion and, last but not least, institutional structure in accordance with the division of powers and competencies in the system of public administration organization" (Skulová, 1996). Any decision issued by an administrative body must comply with the requirements of the Code of Administrative Procedure and contain the operative part, the justification and the instructions of the participants on the remedies. Tab. 4 is the number of individual decisions issued by the Office for the period 2012-2016. In 2016, one-third of the entities were appealed against the first-instance decision and, on the basis of the decomposition, the Office initiated new proceedings. In the following years, the number of respondents ranged between 18 and 28%.

*Table 4: Number of decisions issued and decisions on decomposition (own processing according to the annual reports of the Office)*

	Number of first-degree decisions issued	Number of decomposition decisions issued	Total
2016	943	480	1 423
2015	1 074	423	1 497
2014	1 063	368	1 431
2013	959	282	1 241
2012	1 049	229	1 278

If the contracting authority commits a violation of the Public Procurement Act when awarding a public procurement, the Office shall impose a fine on the entity in accordance with the law and the degree of fault. Every year, the Office will impose a fine in the amount of over ten million crowns. As shown in Table 5, a significant increase in fines was imposed in 2014 and a little lower in 2013. Other years, the fines imposed were around 30 million crowns. In the event that some entities disagree with the first-instance decision, they may file a hearing. On the basis of the lodged decomposition, the Office may take into consideration the objections raised in the declassification and the first-instance decision to cancel or change. Cancellation or change may also apply to the amount of the fine imposed. In the column of the amount of the fine imposed in the second stage, it can be seen that some organizations have succeeded in reducing the overall obligation to pay the penalty for each period. The final amount may be even lower, as the unsuccessful body can still apply to the courts, which may also reduce or cancel the fine. If the court considered the entity to be true, the Office would have the obligation to repay the money paid and, moreover, to pay interest on the amount arrested, but the percentage of success in the judicial inquiries is in favor of the Office. Only in 2012 in each second judicial review was a positive result for the Office. From 2013, the success rate is 98% and higher. In 2016, the Office ordered the payment of 78 costs, that is, on average, every eighteenth subject of the proceedings had to pay the costs of the Office for the control process. In previous years the Office decided to pay the costs of the body more than in 2016. The costs of one procedure amounted to about CZK 30,000. The last column of Tab. 5 is the amount of the failed deposit, which has become the revenue of the state budget. Submission of a proposal by a participant to an error in the award procedure is based on the lodging of a deposit to prevent the submission of purposeful and unreasonable proposals. In 2013, the amount of CZK 16,350,000 was transferred to the state budget.

*Table 5: The total amount of imposed fines, costs of proceedings and the amount of the deposit lost, in thous. CZK (own processing according to the annual reports of the Office)*

	The amount of the fine imposed in stage 1	The amount of the fine imposed in stage 2	Amount of the costs incurred	The amount of the deposit lost
2016	34 441	26 717	2 340	11 566
2015	31 790	19 357	2 700	9 734
2014	72 421	41 265	3 067	6 547
2013	58 761	28 555	3 520	16 350
2012	39 511	22 085	3 420	5 689

Efficiency is generally the ratio of outputs and inputs. The goal of efficiency is to minimize costs or maximize benefits. However, the contribution is only a rough analysis of effectiveness. The primary objective of the Office is not to generate profits or to select the largest amount of funds, but to oversee the economic market and to prevent unfair competition, abuse of dominant market position and other competencies already mentioned. Tab. 6 shows the amount of funds attributable to the operation of the whole of the Office and also what part of this amount belongs only to the section dealing with public contracts. The total cost of the public procurement section is calculated as the total cost multiplied by the percentage of the persons involved in public procurement at the Office. Costs are calculated by counting all decisions issued since, in the event of an appeal, the employees of the Office must re-acquaint themselves with a specific case and set the time needed to assess the issue. The number of decisions includes also interim measures, as well as those which are dismissed and revoked. The average cost per review is then calculated as the total cost of the public procurement section for the total number of decisions. The average cost of one review was CZK 70,000 in 2012. Since then, one review by the employees of the Office has been significantly reduced, to CZK 47,000 in 2016.

*Table 6: Costs of the Office for the period 2012 - 2016, in thous. CZK (own processing according to the annual reports of the Office)*

	<b>Total cost</b>	<b>Total cost of the PP section</b>	<b>Number of decisions</b>	<b>Average cost / review</b>
<b>2016</b>	203 475	67 147	1 423	47
<b>2015</b>	197 159	67 472	1 497	45
<b>2014</b>	202 268	72 783	1 431	51
<b>2013</b>	210 745	77 798	1 241	63
<b>2012</b>	241 785	89 460	1 278	70

Tab. 7 shows the amount of the Office's revenues. Deliberate revenue is the sum of the fines imposed in the second stage, the amount of the costs and the amount of the forfeited deposits. The total amount of revenue does not include an amount that would correspond to the sum of the charges for the complaints submitted. The incentives are charged from October 2016 and the fee has reduced the number of complaints filed, so I consider this amount to be non-material for the calculation of the gross effectiveness analysis. Revenues are considered to be notional because they are not included in the budget of the Office but in the budget of the state. The average earnings per review are calculated as the sum of total earnings per number of decisions per year. In 2013, a higher number of bail went down than in other years, so the average income this year is significantly higher than in other years. In 2014, on the other hand, the level of fines paid in level 2 dominated, which reflected higher average income for review.

*Table 7: Revenues of the Office for the period 2012 - 2016, in thous. CZK (own processing according to the annual reports of the Office)*

	<b>Total Revenues</b>	<b>Number of decisions</b>	<b>Average revenue / review</b>
<b>2016</b>	40 623	1 423	29
<b>2015</b>	31 791	1 497	21
<b>2014</b>	50 879	1 431	36
<b>2013</b>	48 424	1 241	39
<b>2012</b>	31 194	1 278	24

Tab. 8 shows the comparison of the national revenues and costs of the Office. The table shows that the average cost of one review has decreased since 2012. On the other hand, the average income from one review in 2016 is only five thousand higher than it was in 2012. The Office's activity has long been inefficient in this respect and its operation must be subsidized from the state budget.

*Table 8: Comparison of cost and income per review, in thous. CZK (own processing according to the annual reports of the Office)*

	<b>Average cost / review</b>	<b>Average revenue / review</b>
<b>2016</b>	47	29
<b>2015</b>	45	21
<b>2014</b>	51	36
<b>2013</b>	63	39
<b>2012</b>	70	24

The results of the survey are compared with the results from previous research, which dealt with similar facts in other years in Tab. 9 (Bachan 2009, Čechová 2011, Pavlas 2017). The only difference between the comparative research is that the Čechová's and Bachan's researches include entities controlled by the Office, as well as entities, audited from the point of view of the Supreme Audit Office. This difference can be considered as minimal with respect to the number of responses.

*Table 9: Comparing the results of the survey with the results of previous research (own processing according to the annual reports of the Office)*

	<b>Bachan</b>	<b>Čechová</b>	<b>Pavlas</b>	<b>Own research</b>
<b>Judicial proceedings are not underway (n)</b>	33	30	36	41
<b>The responsible person designated</b>	11	12	17	18
<b>% of n</b>	33,33 %	40,00 %	47,22 %	43,90 %
<b>Compensation required</b>	6	9	14	13
<b>% of n</b>	18,18 %	30,00 %	38,89 %	31,71 %
<b>Other measures have been taken</b>	16	9	15	26
<b>% z n</b>	48,48 %	30,00 %	41,67 %	63,41 %

Even though publications and methodical guides on the interpretation of the law have been published since the beginning of validity of the Act No. 137/2006 Coll. On Public Procurement, there has been no increase in the knowledge and experience of the employees of individual entities who have or were obliged to award the contract within the framework of the aforementioned Act. This is reflected in Table 9, where, on the basis of a comparison of individual surveys, it can be said that the control system is long-term ineffective. The only improvement is seen in the number of entities that have taken other measures to avoid recurring errors and shortcomings in the procurement procedure. As mentioned above, an example may be the adoption of a new directive or revision of existing, ongoing employee training, the use of external advice, a multi-level check, and others.

#### **4. CONCLUSION**

Legislation on public procurement has undergone several minor changes over the last few years. The biggest change took place in 2016 when a new law came into force incorporating the requirements of EU directives. It is clear from the very scope of the new Public Procurement Act that public procurement is a very comprehensive and demanding topic. The volume of public procurement significantly contributes to the amount of annual GDP and, as a result, public goods are redistributed; therefore, it is important to regulate this area by legislation, but also to supervise and control the ineffective management of public funds. That power lies in particular with the Office. Based on research over the period 2013 to 2014, the effectiveness of the Office supervision is low. The inefficiency stems primarily from the unwillingness to identify the responsible person who caused the breach of the law. There may be several reasons - indifference, personal ties to the job, or the mere fact that it is public finance. The organizational components of the state appeared among the often punished subjects in the research. If such a body is fined, it can be said that the state is imposing it on itself. In terms of public budgets, these penalties have a neutral impact but are linked to the Office's administrative costs. Employees of the fined organizational unit of the state do not solve the administrative costs associated with the imposition of a fine and any appeal, even though they are all of us.

It is these subjects who do not have to identify a particular person. For others, the fine can mean a meaningful interference in their budgets. For this reason, external firms are used to a greater extent and, in the case of a properly drawn up contract, they may claim damages in the amount of the fine imposed. Infringement of the Public Procurement Act may also occur due to the ignorance and complexity of the law. Difficulty can also be reflected in the more frequent use of external firms.

**ACKNOWLEDGEMENT:** *This contribution was supported by SGS\_2018\_18.*

#### **LITERATURE:**

1. Act No. 137/2006 Coll. on Public Procurement. In: Sbíрка zákonů České republiky.
2. Act No. 106/1999 Coll. on Free Access to Information. In: Sbíрка zákonů České republiky.
3. Act No. 134/2016 Coll. on Public Procurement tendering. In: Sbíрка zákonů České republiky.
4. Bachan, M. (2009). Kontrola zadávání veřejných zakázek (bakalářská práce). Vysoká škola ekonomická v Praze, Fakulta financí a účetnictví, Katedra veřejných financí, 55 p.
5. Čechová, L. (2011). Efektivnost kontrol ÚOHS a NKÚ v oblasti veřejných zakázek (bakalářská práce). Vysoká škola ekonomická v Praze, Fakulta financí a účetnictví, Katedra veřejných financí, 43 p.
6. Gavurova, B., Tucek, D., Tkacova, A. and Danko, J. (2018). Public procurement efficiency in agriculture and forestry in Slovakia. *Administrative Management Public*, (30), pp. 24-36.
7. Halásková, M. & Halásková, R. (2018). Evaluation Structure of Local Public Expenditures in the European Union Countries. *Acta Universitatis Agriculturae et Silviculturae Mendelianae Brunensis*, 66(3), pp.755-766.
8. Judgment of the Supreme Administrative Court of 6.6.2013, čj. 1 Afs 106/2012 - 45
9. Judgment of the Supreme Administrative Court of 27.3.2008, čj. 4 AS 51/2007 - 68
10. Pavlas, V. (2011). Účinnost dohledu ÚOHS v oblasti veřejných zakázek (bakalářská práce). Vysoká škola ekonomická v Praze, Fakulta financí a účetnictví, Katedra veřejných financí, 41 p.
11. Skulová, S. (1996). Rozhodování ve veřejné správě. 2. přeprac. vyd. Brno: Masarykova univerzita, Spisy Právnické fakulty Masarykovy univerzity v Brně, ed. 177. ISBN 80-210-1458-X.
12. Soukopová, J. & Bakoš, E. (2017). Unfair competition and its impact on municipal spending on waste management. *Scientific Papers of the University of Pardubice. Series D, Faculty of Economics & Administration*, 24(39).
13. Office For The Protection Of Competition (2012). Annual report 2012 [online]. Available at: <https://www.uohs.cz/cs/informacni-centrum/vyrocnizpravy.html>
14. Office For The Protection Of Competition (2013). Annual report 2013 [online]. Available at: <https://www.uohs.cz/cs/informacni-centrum/vyrocnizpravy.html>
15. Office For The Protection Of Competition (2014). Annual report 2014 [online]. Available at: <https://www.uohs.cz/cs/informacni-centrum/vyrocnizpravy.html>
16. Office For The Protection Of Competition (2015). Annual report 2015 [online]. Available at: <https://www.uohs.cz/cs/informacni-centrum/vyrocnizpravy.html>
17. Office For The Protection Of Competition (2016). Annual report 2016 [online]. Available at: <https://www.uohs.cz/cs/informacni-centrum/vyrocnizpravy.html>
18. Office For The Protection Of Competition (2018a). Chapter Budget. MONITOR [online]. [cit. 2018-04-10]. Available at: <https://monitor.statnipokladna.cz/2016/statni-rozpocet/kapitola/353#rozpocet-vydaje-odvetvovy>
19. Office For The Protection Of Competition (2018b) Public Procurements [online]. [cit. 2018-04-08]. Available at: <http://www.uohs.cz/cs/verejne-zakazky.html>
20. The Ministry Of Local Development Of The Czech Republic: Annual Report on the State of Public Procurement. 2017 [online]. Available at: [http://www.portal-vz.cz/getmedia/596b6316-9683-4f9e-8157-a42211f60404/III\\_Vyrocnizprava-o-stavu-verejnych-zakazek-v-Ceske-republice-za-rok-2016\\_final.pdf](http://www.portal-vz.cz/getmedia/596b6316-9683-4f9e-8157-a42211f60404/III_Vyrocnizprava-o-stavu-verejnych-zakazek-v-Ceske-republice-za-rok-2016_final.pdf)

## WOMEN IN MANAGEMENT - RESEARCH IN REPUBLIC OF CROATIA

**Igor Klopotan**

*University North, Croatia  
igor.klopotan@unin.hr*

**Vesna Sesar**

*University North, Croatia  
vesna.sesar@unin.hr*

**Ivana Martincevic**

*University North, Croatia  
ivana.martincevic@unin.hr*

### **ABSTRACT**

*It is unthinkable that organizations today perform without quality management that is responsible for leading and directing the organization toward goal achievements. Today, women are equally good at managerial job position as male managers. However, due to various prejudices and discrimination, woman still have difficulties climbing the corporate ladder. The glass ceiling phenomenon is still present in world researches as well as in Croatia pointing out woman under-representation on managerial positions where they face difficulties while trying to reach higher corporate levels.*

**Keywords:** *management, glass ceiling phenomenon, female managers*

### **1. INTRODUCTION**

In today's business environment and the world of managers, men dominate high level positions in business and women managers have difficulties while climbing the corporate ladder and reaching top level positions. Precisely when we talk about management levels and leading the business at top level positions, women are often involved in doing business at middle and lower management levels. However, organizations today succeed mainly regarding their people (based on intellectual they possess) and based on their synergy and co-operation. In spite of the need that a person has to possess specific managerial skills for certain managerial positions, managerial function is still created based on a gender criterion. Competence is measured based on a person's knowledge, skill, desire for learning and the ability to overcome challenges, so for that very reason, regardless of the business type and position we address, the most important is the business ability of an individual rather than a gender. Although society developed and the world is more civilized, the gap between the compensation of male and female managers continues to exist, which ultimately leads to the conclusion that women tend to succeed harder in their careers and that along the way they have to give up a certain aspect of family life in order to succeed. Hence, the existence of mild women discrimination is apparent and their rougher path while climbing the corporate ladder. Recent research, however, speak about increasingly significant involvement of women in the world of management. Women involvement in management significantly influences many changes in management structure, the way it performs and communication with co-workers and subordinates (Novak, 1996, p35), where women managers take positions at different levels in organizational hierarchy with different management approach that enables easier and more successful problem solving and generally better management of organizations.

## **2. THE PRESENCE OF WOMEN IN MANAGEMENT AND THE GLASS CEILING EFFECT**

There are many approaches in defining a management as well as sole definitions of management. There are many authors who have defined management. Management can be viewed and defined from several aspects. Management is a business process the carrier of specific organization functions, skills, scientific discipline, profession, or a function in organization. (Sikavica, Bahtijarević-Šiber, Pološki Vokić 2008, p.8). Today, successful companies differ from unsuccessful ones by management style or styles. The manager is a person whose primary tasks come from process management - he plans and makes decisions, organizes work and business, engages and leads people, and controls human, financial, physical and informational resources. (Buble, 2006). The job of a manager is dynamic and demanding where he has to fully understand how a business system functions and be ready to respond to market challenges. Nowadays, managers have to have knowledge in many different areas to a large extent while one of the key competencies that a manager has to have is the ability to make priorities and manage change. No matter if a manager is a male or female, he or she have to possess competences, knowledge and skills necessary to lead and manage organization. The success of a manager depends more on knowledge and skills than personality. (Bahtijarević-Šiber, 2008, p. 3). All findings and facts indicate that knowledge and skills are crucial for success, but there is still contradiction and a gap between male and female managerial positions. When it comes to performing managerial jobs at different management levels and management related functions, women are still in most cases successfully involved in lower and middle management levels, while on top management positions, vertical segregation is expressed regarding managerial positions (Bahtijarević-Šiber and Sikavica 2004, p.52), respectively job distribution with regard to hierarchical levels on male jobs at top management levels and equal distribution of male and female jobs at middle and lower management levels. Namely, the key to success of an organization is based on the intellectual capital that an organization has, for example, people working for the organization, based on their synergy and co-operation, but despite the fact that for management position a person has to possess certain competences and skills, positions are still created according to gender criterion. To overcome these obstacles, changes in attitudes and values are needed in society. Countries in which globalization is more expressed (development of information, infrastructure development, gender equality ...) favors women because they are increasingly appreciated as a great help and improvement in business world (Pološki, 2001). By participating in management, women establish a so-called mixed management which influences on management design in organization, better relationships with subordinates and associates, and more versatile thinking about business and its development, so in that way including women in management is economically viable (Bedečković, Ravlić, 2011). One of the largest and most important researches conducted in the Republic of Croatia regarding male and female representation on managerial and leadership positions was conducted by Ombudsperson for Gender Equality of the Republic of Croatia in 2011 on 500 large and most successful companies in Croatia. The data collected state that women constitute only 35% of all senior positions. A great emphasis in EU has been put on achieving the gender equality, so through Croatia by joining EU has to strive for and promote gender equality. Regardless of the increasing presence of highly educated and qualified women in the labor market, women still continue to be on jobs that are less paid and on lower positions with smaller responsibilities. Women in management generally are promoted to lower or middle management levels while breaking through the top positions is still difficult and sometimes we can claim unavailable. For that reason, we can talk and argue about the existence of "Glass Ceiling" phenomenon. "Glass-ceiling" in the economic sense refers to the invisible "ceiling" as a barrier for women wishing to be promoted to higher managerial positions. The term "glass ceiling" was created in the seventies of the last century with the aim to describe the obstacles



woman meet while thriving to be promoted in managerial environment that is conditioned by attitude prejudice and prejudice in companies itself, where a way toward the highest managerial positions for women is dimmed (Wirth 1998: 3). The glass ceiling, respectively the elements that represent obstacle for women to progress at highest management levels (inadequate working hours, lack of female role models, unequal employment opportunities for women, prejudices about women's poor managerial skills, etc.) are divided into causes at society level, institutions or individuals, causes of woman and men behavior, historical and contemporary causes (Prijić -Samaržija, 2009). At the global level, there is a growing number of companies recognizing the importance of greater woman involvement in management, while in Croatia still exist a certain gap and prejudices. We are getting closer to making positive moves, but still situation is far from full gender equality in business organizations.

### **3. LITERATURE REVIEW**

The topic on gender equality is covered and studied through numerous scientific articles and it is also defined and regulated by numerous laws. Also represents one of EU goals including Croatia (European Commission 2012, Gender Equality Act 2008, 2017). Leading and managing is historically attributed to male managers, respectively managerial positions belong to male managers. Based on previous research and review of literature there is extensive research data about woman in management, and accordingly, it is visible through many researches that women face with difficulties when trying to reach higher managerial position, this phenomenon is explained as "Glass Ceiling" phenomenon. Both worldwide researches and researches in Croatian analyse this field of management by researching gender discrimination and representation of women in management positions. The research conducted in 2016 by Jalšenjak and Krkač in Croatia gives evidence of the existence of a glass ceiling phenomenon in business organizations describing the obstacles that employees face on their jobs that are linked with gender discrimination. An interesting research was done in 2016 in Croatia (Vranješ Radanović et al., 2016) where data pointed out that women accepted positions in management much later and also leave earlier, which is also related to the fact that they later start their jobs and leave earlier. Recent world studies have also analysed this management field and they are investigating that the glass ceiling phenomenon prevents certain individuals from advancing or reaching positions in management (Smith, Caputi, Crittenden, 2012). Results of the research conducted in Croatia show that women share 35% of all leading positions. The data is even worse when analysing women's participation in top management levels. In 91% of all management boards is a male person. Only 9% of them are women. In 89% of supervisory boards are men engaged while in only 11% are women engaged (Ombudsperson for Gender Equality, 2011). The most recent research done in Croatia by Visnjic et al., 2018, examines perceptions and personal attitudes of respondents, and their opinion on whether women and men have equal employment opportunities and advancement in Croatia. They also investigate whether, on their opinion, for women is harder to reach positions in management and what is their dominant decision-making style and the way of making decisions in business organizations. The results on a sample of 112 respondents that are on managerial positions in business organizations show that gender equality has not been achieved. Authors Ružić, Perušić (2014) speak about "Glass Ceilings" phenomenon, respectively, examine the phenomenon where they conclude that there is a sub-representation of women in managerial positions, but also show that a management model distinctive for women, is more adequate and more acceptable in a turbulent business environment and that women in their managerial skills even outperform men. In order to investigate the existence of a "glass ceiling" phenomenon, respectively women position in managerial positions in local government units and regional self-government units in Virovitica podavska, authors Bedeković, Ravlić (2011) pointed out that there still exist the influence of tradition as well as prejudices since women are still not the

"right choice" for managerial positions and jobs at various hierarchical management levels, especially at the top level. Research done by Prijić-Samaržija et al. (2008) also investigate and prove the existence of a "glass ceiling", ie the under-representation of women in managerial positions in institutions of science and higher education in the Republic of Croatia. Galičić, Ivanović (2006) investigate women representation in managerial positions in the Croatian hotel industry, where they also claim that there is no equality among men and women in managerial positions. Penava and Šehić (2007) conducted a research on women position in management in Bosnia and Herzegovina (BH). Research results confirm the existence of a "glass ceiling" phenomenon in those organizations. Research results show that women managers are mostly on lower management levels, which does not allow them to engage significantly in strategic decision-making processes in companies. Research by Puhalo and Puhalo (2004) proves that women managers in Bosnia and Herzegovina show a greater need for success and are willing to invest more effort and intellectual potential in achieving business goals than male colleagues.

## **4. RESEARCH**

### **4.1. Research methodology**

A review of literature and scientific articles was conducted to identify the relevant instruments for measuring characteristics of manager. For the purpose of this research, a research instrument was created based on the work of Zenger and Folkman (2012), Penava and Šehić (2007., 2014.), Pološki (2003), Perkov (2016), and was adjusted according to the research needs. Target population of the research are those who are employed and who can evaluate and recognize manager characteristics. For this purpose, a research tool with 16 statements was created describing manager characteristics. Also, demographic data of respondents were collected as well as statements regarding the problem of women's advancement, known as the "glass ceiling". Computer Assisted Web Interviewing (CAWI) survey was conducted in the period from 10 to 21 June 2018. Respondents were selected randomly from a database of e-mail addresses. The link to the survey was sent to every fifth e-mail address in the database, containing a total of 2,500 addresses, thus creating a sample of 500 respondents. 131 individuals have completed the questionnaire and sent it back. From further data processing were excluded answers of respondents who have never worked because they were considered without experience to evaluate survey statements. For the purposes of this research, 100 respondents (N = 100) were taken, which represents a 20% of the total sample. The first section of the questionnaire contains questions about the socio-demographic profile of respondents, i.e. gender, age, level of education, employment status. The second section of the questionnaire sadrži 16 tvrdnji koje opisuju karakteristike menadžera, a ispitanici ocjenjuju muške i žene menadžere što je prikazano u Tablici 2. Respondents were asked to indicate their level of agreement on a 5-point scale, with 1 being "strongly disagree" and 5 being "strongly agree".

*Table following on the next page*

*Table 1: Respondents characteristics*

	Structure in %	Cumulative %
<b>Gender</b>		
Male	31	31
Female	69	100
<b>Age</b>		
Until 25	20	20
26-35	30	50
36-45	33	83
More than 45	17	100
<b>Education</b>		
High school graduate	27	27
Vocational school	27	54
College graduate	42	96
Masters or doctorate	4	100
<b>I cooperate better with a woman manager</b>		
Yes	80	80
No	20	100
<b>Women better run the company in crisis</b>		
Yes	47	47
No	53	100
<b>Should a woman sacrifice family for career?</b>		
	11	11
Yes	89	100
<b>Are you familiar with the "glass ceiling" term ?</b>		
Yes	41	41
No	59	100
<b>Women should be equal with male rearding everything</b>		
Yes	55	55
No	45	100
<b>Do you think that jobs in management are male reserved?</b>		
Men have greater authority and they are more capable of performing demanding management tasks.	11	11
Some jobs are traditionally male, so is the management.	7	18
Women are primarily mothers and their place is in the family.	3	21
I disagree, women are capable of performing managerial jobs.	79	100

Table 1 represents demographic characteristics of respondents and their answers on statements regarding the glass ceiling term. The results show that the most respondents are female (69%), older than 30 years and have finished university. Likewise, 80% of the respondents claim they work better with a woman on manager position and 89% believe that women should not sacrifice family life for careers. Respondents opinions are divided regarding statement that a woman runs a company better in a crisis (53% of respondents answered negative to this question), and only 41% of respondents are familiar with the glass ceiling term. Regarding the statement: "Women should be equal with male regarding everything" as well as in career advancement, 55 percent of the respondents responded that they agree with the statement. 79% of the respondents disagree with the statement: "Do you think that jobs in management are male reserved".

*Table 2: Research instrument description (developed and calculated by authors)*

Item	Female manager	Male manager
<b>Takes Initiative</b>	3,44 (1,054)	2,95 (1,317)
<b>Practices Self-Development</b>	3,84 (,974)	2,95 (,887)
<b>Displays High Integrity and Honesty</b>	3,74 (,938)	2,80 (,834)
<b>Drives for Results</b>	3,45 (1,101)	2,75 (,639)
<b>Develops Others</b>	3,58 (,925)	2,75 (1,020)
<b>Inspires and Motivates Other</b>	3,59 (1,087)	2,85 (,933)
<b>Builds Relationships</b>	3,54 (1,018)	2,75 (1,020)
<b>Collaboration and Teamwork</b>	3,56 (,992)	3,00 (,918)
<b>Establishes Stretch Goals</b>	3,43 (1,028)	3,10 (1,021)
<b>Champions Change</b>	3,21 (1,052)	3,00 (1,076)
<b>Solves Problems and Analyzes Issues</b>	3,58 (,883)	2,95 (1,050)
<b>Communicates clearly and accurately</b>	3,73 (1,043)	3,10 (,968)
<b>Connects the Group to the Outside World</b>	3,46 (,993)	2,90 (,912)
<b>Innovates</b>	3,59 (1,027)	3,05 (,826)
<b>Technical or Professional Expertise</b>	3,18 (1,077)	3,25 (1,118)
<b>Develops Strategic Perspective</b>	3,30 (,986)	3,00 (1,026)

Table 2 represents a research tool containing 16 statements. The respondents have evaluated according to those 16 statements the importance of each competence and the relation between male and female manager. The research results show that the most important woman competences are: (1) Practices Self-Development, (2) Displays High Integrity and Honesty i (3) Communicates clearly and accurately. Regarding male managers, the most relevant competencies according to their answers are: (1) Technical or Professional Expertise, (2) Establishes Stretch Goals i (3) Communicates clearly and accurately.

## 4.2. Research hypothesis

In order to examine whether there are statistically significant differences between the groups of respondents, the following hypotheses of the paper were set:

- H1: There is a difference in statement valuation regarding managers gender and age characteristics and educational level of respondents.
- H2: There is a difference in statement valuation regarding manager characteristics and statement referring to "glass ceiling" term.

The Shapiro-Wilk normality test was used to check the distribution. It showed that none of the parameters were normally distributed, Sign. = 0.000. This is concluded since the significance level is less than  $\alpha=0.05$  (Sig. <0.05), i.e. the significance level of all variables is ~ 0.000. Therefore, the assumption of normal distribution of data can be rejected. The Kruskal - Wallis test which is based on the observation rankings from samples will be used in SPSS. The null hypothesis assumes that population means are identical for all population groups. To test the null hypothesis, respondents were divided by gender, age and education. The test results show that at statistically significant coefficient levels there are statistically significant difference between key parameters which describe manager's characteristics related to respondent's gender. They are as follows:

- Takes Initiative – with confidence level at Sig.=0.035
- Practices Self-Development – with confidence level at Sig.=0.009
- Displays High Integrity and Honesty – with confidence level at Sig.=0.000
- Drives for Results – with confidence level at Sig.=0.029
- Develops Others – with confidence level at Sig.=0.020
- Inspires and Motivates Other – with confidence level at Sig.=0.001
- Builds Relationships – with confidence level at Sig.=0.045
- Collaboration and Teamwork – with confidence level at Sig.=0.003
- Establishes Stretch Goals – with confidence level at Sig.=0.000
- Champions Change – with confidence level at Sig.=0.023
- Solves Problems and Analyzes Issues – with confidence level at Sig.=0.000
- Communicates clearly and accurately – with confidence level at Sig.=0.001
- Connects the Group to the Outside World – with confidence level at Sig.=0.021
- Technical or Professional Expertise – with confidence level at Sig.=0.032
- Develops Strategic Perspective – with confidence level at Sig.=0.035

In respondent's groups divided by education and age there is no statistically significant difference. The first hypothesis "H1: There is a difference in statement valuation regarding managers gender and age characteristics and educational level of respondents". The first hypothesis: H1 There is a difference in valuation key parameters which describe manager characteristics according to sex, age and level of education of the respondents, can be partially accepted as there are no statistically significant differences in the groups of respondents regarding education and age. The test results show that at statistically significant coefficient levels there is a statistically significant difference between key parameters which describe manager characteristics related to statement: "I cooperate better with a woman manager". They are as follows:

- Practices Self-Development – with confidence level at Sig.=0.002
- Displays High Integrity and Honesty – with confidence level at Sig.=0.019
- Develops Others – with confidence level at Sig.=0.001
- Collaboration and Teamwork – with confidence level at Sig.=0.036
- Establishes Stretch Goals – with confidence level at Sig.=0.040

- Solves Problems and Analyzes Issues – with confidence level at Sig.=0.018
- Communicates clearly and accurately – with confidence level at Sig.=0.001
- Innovates – with confidence level at Sig.=0.007

The test results show that at statistically significant coefficient levels there is a statistically significant difference between key parameters which describe manager characteristics related to statement: “Women better run the company in crisis”. They are as follows:

- Takes Initiative – with confidence level at Sig.=0.016
- Practices Self-Development – with confidence level at Sig.=0.000
- Displays High Integrity and Honesty – with confidence level at Sig.=0.000
- Develops Others – with confidence level at Sig.=0.000
- Inspires and Motivates Other – with confidence level at Sig.=0.000
- Builds Relationships – with confidence level at Sig.=0.000
- Collaboration and Teamwork – with confidence level at Sig.=0.001
- Establishes Stretch Goals – with confidence level at Sig.=0.000
- Champions Change – with confidence level at Sig.=0.012
- Solves Problems and Analyzes Issues – with confidence level at Sig.=0.000
- Communicates clearly and accurately – with confidence level at Sig.=0.001
- Connects the Group to the Outside World – with confidence level at Sig.=0.003
- Innovates – with confidence level at Sig.=0.022
- Develops Strategic Perspective – with confidence level at Sig.=0.016

The test results show that at statistically significant coefficients there is a statistically significant difference between key parameters that describe manager characteristics related to statement "Are you familiar with the “glass ceiling” term?". They are as follows:

- Connects the Group to the Outside World – with confidence level at Sig.=0.039

The test results show that at statistically significant coefficient levels there is a statistically significant difference between key parameters which describe manager characteristics related to statement: “Women should be equal with male regarding everything”. They are as follows:

- Takes Initiative – with confidence level at Sig.=0.000
- Practices Self-Development – with confidence level at Sig.=0.007
- Inspires and Motivates Other – with confidence level at Sig.=0.014
- Builds Relationships – with confidence level at Sig.=0.009
- Connects the Group to the Outside World – with confidence level at Sig.=0.003
- Develops Strategic Perspective – with confidence level at Sig.=0.000

*Table following on the next page*

*Table 3: Post-hoc Mann-Whitney test for different groups - Do you think that jobs in management are male reserved? (statistically significant differences) (developed and calculated by authors)*

ITEM	GROUPS	MANN-WHITNEY U	ASYMP. SIG. (2-TAILED)
Develops Others	Men have greater authority and they are more capable of leading demanding managerial jobs - Some jobs are traditionally male, so is the management.	17,000	0.035
Inspires and Motivates Other	Men have greater authority and they are more capable of leading demanding managerial jobs - Some jobs are traditionally male, so is the management.	14,500	0.022
Communicates clearly and accurately	Men have greater authority and they are more capable of leading demanding managerial jobs - Some jobs are traditionally male, so is the management.	14,000	0.014
Takes Initiative	Men have greater authority and they are more capable of leading demanding managerial jobs - I disagree, women are capable of performing managerial jobs.	283,500	0.045
Practices Self-Development	Men have greater authority and they are more capable of leading demanding managerial jobs - I disagree, women are capable of performing managerial jobs.	142,500	0.000
Develops Others	Men have greater authority and they are more capable of leading demanding managerial jobs - I disagree, women are capable of performing managerial jobs.	261,000	0.024
Inspires and Motivates Other	Men have greater authority and they are more capable of leading demanding managerial jobs - I disagree, women are capable of performing managerial jobs.	222,500	0.006
Establishes Stretch Goals	Men have greater authority and they are more capable of leading demanding managerial jobs - I disagree, women are capable of performing managerial jobs.	274,000	0.037
Solves Problems and Analyzes Issues	Men have greater authority and they are more capable of leading demanding managerial jobs - I disagree, women are capable of performing managerial jobs.	224,000	0.006
Communicates clearly and accurately	Men have greater authority and they are more capable of leading demanding managerial jobs - I disagree, women are capable of performing managerial jobs.	253,500	0.019
Innovates	Men have greater authority and they are more capable of leading demanding managerial jobs - I disagree, women are capable of performing managerial jobs.	250,500	0.015
Develops Strategic Perspective	Men have greater authority and they are more capable of leading demanding managerial jobs - I disagree, women are capable of performing managerial jobs.	283,500	0.045

Post-hoc Mann-Whitney test has been used to determine exactly between which groups there is a statistically significant difference. Table 3 shows the results of the test and the reliability of the test by groups. The second hypothesis of the paper "H2: There is a difference in evaluating statements that describe manager characteristics according to statements relating to glass ceiling term" can be accepted since there is a statistically significant difference between groups.

## 5. CONCLUSION

Since the most managerial positions are male reserved, the purpose of this paper was to examine attitudes about male and female manager characteristics, as well as the attitudes about the problem of reaching higher corporate positions for female managers. Researches have shown that women's involvement in management has an impact on communication with associates, where women have different management approach that allows easier and more successful problem solving and generally better organization management. The research results showed that respondents recognize the difference in main manager's characteristics between male and female. The respondents emphasized that the most important competence for female managers is "Practices Self-Development", while for male managers, emphasize "Technical or Professional Expertise". Competence that is equally evaluated in both genders is "Communicates clearly and accurately". The respondent's demographic data showed that in survey participated 69% of women and that 80% of respondents state they have cooperated better with female manager. The results also showed that 59% of respondents do not know the meaning of a term "glass ceiling" phenomenon. The first hypothesis of this paper assumes that there is a difference in evaluating statements describing manager characteristics depending on gender, age and level of respondent's education. The first hypothesis of the paper can be partially accepted as there are no statistically significant differences in respondent groups regarding education and age characteristics. However, 15 statements out of 16 show statistically significant difference regarding gender characteristics among respondents. The second hypothesis of the paper assumes that there is a difference in statement valuation regarding manager characteristics versus statements on the term glass ceiling. The second hypothesis can be accepted since there are statistical differences in both statements. This research has shown that gender equality awareness in the Republic of Croatia is not yet fully developed and that women advancement problem regarding reaching higher managerial positions is not sufficiently communicated, since most of the respondents are not familiar with the phenomenon. What shows possible change in the future, is a positive attitude of 79% of respondents on statements like "jobs in management are not only reserved for male" and "female are equally capable of performing managerial jobs".

## LITERATURE:

1. Aeran, A.: Glass ceiling: a probable speed-braker in the production of quality female management professionals, *Indian J.Sci.Res.* 5(2) : 175-179, 2014.
2. Bahtijarević-Šiber, F.; Sikavica, P.; Pološki Vokić N.: "Suvremeni menadžment – Vještine, sustavi i izazovi,, Školska knjiga, Zagreb, 2008., str. 3.
3. Bedeković, V., Ravlić, Ž. : Položaj žena u rukovodećim strukturama službi jedinica lokalne uprave i područne (regionalne) samouprave na primjeru virovitičko podravske županije, *Praktični menadžment*, Vol. II, br. 2, str. 15-23, 2011.
4. European Commission (2012). Proposal for a Directive of the European Parliament and of the Council on improving the gender balance among non-executive directors of companies listed on stock exchanges and related measures, preuzeto <http://eur-lex.europa.eu/legal-content/EN/TXT/?uri=CELEX%3A52012PC0614>
5. Galičić, V., Ivanović, Z.: Žene menadžeri u hrvatskom hotelijerstvu, *Tourism and Hospitality Management*, Vol. 12, No. 1, pp. 79-88, 2006.,



6. Jalšenjak B., Krkač K. (2016), Poslovna etika, korporacijska društvena odgovornosti i održivost, (2.prepravljeno i prošireno izdanje), Zagreb, MATE, str.518
7. Lyness, K. S., & Thompson, D. E. (2000). Climbing the corporate ladder: Do female and male executives follow the same route? *Journal of Applied Psychology*, 85(1), 86-101.
8. Nidogan Višnjjić, S., Begičević Ređep, N., Vidaček-Hainš, V., (2018.), Stavovi i percepcije žena na rukovodećim pozicijama o njihovom položaju na radnom mjestu, *Ekonomski misao i praksa dbk. god XXVII. (2018.) br. 1. (287-313)*
9. Penava, S., & Šehić, D. (2007). Žene u menadžmentu bosanskohercegovačkih kompanija. *Ekonomski pregled*, 58(5-6), 305-327.
10. Penava, S., & Šehić, D. (2014). The relevance of transformational leadership in shaping employee attitudes towards organizational change. *Economic Annals*, 59(200), 131-162.
11. Perkov, D., Primorac, D., & Perkov, M. (2016). Position of female managers in Croatian tourism. *International Journal of Economic Perspectives*, 10(1), 62-70.
12. Pološki, N. (2003). "ŽENSKI STIL" VOĐENJA-EMPIRIJSKO ISTRAŽIVANJE PRIMARNIH NOSITELJA U HRVATSKIM PODUZEĆIMA. *Ekonomski pregled*, 54(1-2), 38-54.
13. Pološki, N.: "Basic requirements for the successful implementation of the "feminine leadership,, style in croatian enterprises,, Management: journal of contemporary management issues, Vol. 6, No 1-2, 2001., str. 122
14. Prijic-Samaržija, S., Avelini Holjevac, I., Turk, M.: Žene u znanosti: Stakleni strop, Društvena istraživanja, Zagreb, god.18 (2009), br. 6 (104), str. 1049-1073
15. Puhalo, A. A., Puhalo, S. (2004.). "Menadžeri u Bosni i Hercegovini- Neke karakteristike menadžerki u odnosu na menadžere i žene nemanadžere" Gender Centar Vlade Federacije BiH i Gender Centar Vlade Republike Srpske
16. Ružić, V., Perušić, M.: Položaj žena u menadžmentu – novi trendovi u fenomenu staklenog stropa, *Praktični menadžment*, Vol. V., br. 1., str. 98-107, 2014.
17. Sikavica, P., Bahtijarević-Šiber, F., Pološki Vokić, N., (2008). *Temelji menadžmenta*, Zagreb, Školska knjiga
18. Smith, P., Caputi, P., Crittenden, N., (2012). Amaze of metaphors around glass ceilings. *Gender in Management: An International Journal*, 7, str. 436.-448
19. Virginia E. Schein: Women in management: reflections and projections", *Women in Management Review*, 2007. Vol. 22 Issue: 1, pp.6-18
20. Vranješ-Radovanović, I., Šurina Henzl, G., Selanec, G. Pravobraniteljica za ravnopravnost spolova Republike Hrvatske, (2016), Istraživanje o zastupljenosti žena i muškaraca na upravljačkim pozicijama u Republici Hrvatskoj, Zagreb, preuzeto [http://staklenilabirint.prs.hr/wp-content/uploads/2014/08/PRSRH\\_Izvjesce\\_muskarci-zene500\\_web.pdf](http://staklenilabirint.prs.hr/wp-content/uploads/2014/08/PRSRH_Izvjesce_muskarci-zene500_web.pdf)
21. Yukongdi, Vimolwan, & Benson, John. (2005). Women in Asian Management: Cracking the Glass Ceiling. *Asia Pacific Business Review*, 11(2), 139–148
22. Yukongdi, Vimolwan. (2005). Women in Management in Thailand: Advancement and Prospects. *Asia Pacific Business Review*, 11(2), 267–281.
23. Zakon o ravnopravnosti spolova, NN 82/08, <http://www.zakon.hr/z/388/Zakon-o-ravnopravnosti-spolova>
24. Zenger, J., & Folkman, J. (2012). Are women better leaders than men. *Harvard Business Review*, 15, 80-85.

## QUALITY IN MANAGING A HOTEL ON THE EXAMPLE OF GDYNIA

**Marzena Wanagos**

*Gdynia Maritime University in Gdynia, Poland  
m.wanagos@wpit.am.gdynia.pl*

**Izabela Grajek-Czabajka**

*Gdynia Maritime University in Gdynia, Poland  
iza@spinpr.home.pl*

### **ABSTRACT**

*This study is an attempt to present organizational elements related to quality management in hotels. The main goal was to show whether management through quality is an important decision-making direction of managers in hotels. An attempt was made to answer the following questions: Do hotel managers consider quality issues as important? What quality systems are implemented? Who in the hotel deals with quality management? Are ITC tools used in the quality management process? The study consists of two parts. The first is an analysis of literature and an attempt to present the issue of the quality of hotel services in literature. Issues related to the quality management elements in hotels were raised here. Particular attention has been paid to modern technologies and information and communication systems that have a major impact on the quality of services in the hotel industry. The second part of the article is an analysis of empirical research conducted by means of a diagnostic survey using a questionnaire sent via the Internet to hotel managers in Gdynia. All objects defined in Polish law were examined as hotels located in the city of Gdynia. The study was conducted from July to September 2018. The analysis shows that the vast majority of respondents consider quality to be an important sphere of hotel operation. However, few hotels implement quality systems, in addition to those required by top-down regulations. ITC tools are known by the respondents, but they use them relatively little.*

**Keywords:** *hotel services, quality, quality of service management*

### **1. INTRODUCTION**

Quality is a complex concept used in many scientific disciplines. Often, the definitions emphasize its interdisciplinary character. The issues related to the quality of services are becoming more and more important in the management process from year to year. In highly developed countries, the quality of services has become the basis of competition today. Quality is the main factor determining customer satisfaction, and thus affects the market success of the manufacturer or service provider. The quality of services is a topic that is growing in importance also because we have been observing the growing share of the services sector in the global economy for years. A diverse approach to the issue of quality also translates into difficulties in defining the quality of services. Quality in relation to services is interpreted on many levels, hence various factors become important in the process of shaping quality. Increasingly, the complexity of management in the area of services is also indicated, which makes it difficult to clearly define quality, and using the term quality as an objective category is almost impossible (Ostasiewicz (ed.) 2004, pp.118-120). Thus, the concept of quality of services has not yet been given a single, complete definition. It is also influenced by the very characteristics of the services, which causes that there are often difficulties and ambiguities in the measurement of the quality of such a product. Tourist destinations compete with each other, and the level of hotel services plays an important role in this competition (Małachowski 2015). The competition in the hotel sector growing from day to day as well as the emergence of new technologies and their dynamic development translate into the fact that hotel companies are looking for more

innovative methods of existence and survival on the market. The main goal today is for many of them to overtake competition and win the fight for a loyal customer by providing him with a satisfying quality hotel service. (Rosa, Ostrowska, Słupińska, Player 2018). This, in turn, is at the heart of customer orientation. Many hotel companies wanting to win in a very aggressive fight for clients focus their attention on the implementation and development of pro-quality activities. In the assumption of hotel object managers, such activities cause an increase in competitiveness on the market (Jędrzejczyk 2003, pp. 25-42). Also in Poland, hotels that want to meet galloping competition are forced to improve their activities in the area of quality management of services (Martin 2006, pp. 14-15). The aim of the study is to show whether management through quality is an important decision-making direction of managers in hotels. To realize this objective, hotels in Gdynia were examined. Gdynia is a city on the Gulf of Gdansk, located in the Pomeranian Voivodeship (with a great potential for tourism development). Pomorskie Voivodeship belongs to regions where local governments particularly care about the development of tourism (Wanagos 2010, pp. 109-118). Gdynia, due to its history and specific location as well as its advantages and good transport accessibility, has very good conditions for the development of tourism. Gdynia is a city of small border traffic, which also favors the development of tourism (Zabielska, Zielińska-Szczepkowska 2017, Studzieniecki, Soares. 2017). It is a city inhabited by about 200 thousand. people (Statistical Yearbook of Gdynia, p. 126-142) with a dominant industrial and commercial function (mainly related to the seaport) (Urbanyi-Popiołek, 2014). The main problem of the study was whether the obvious need for the implementation of management through quality in hotels, which is obvious from the theoretical point of view, is being practically implemented. The research covered all hotels in Gdynia, of which there are 13. The hotel in this article is understood as: an object with at least 10 rooms, including most rooms in single and double rooms, providing a wide range of services related to the stay of clients, in accordance with the applicable law in Poland is an object categorized and entered into the government list of such facilities - Central List of Hotel Facilities (Dz.U.2017.0.1553, Act of 29 August 1997 on tourist services, chapter 5).

## **2. MANAGEMENT THROUGH QUALITY IN HOTEL SERVICES**

The definition of high-quality hotel services consists of many factors, and defining it, as well as defining quality in general, turns out to be not easy. The assessment of the quality of hotel services is influenced by many objective and subjective factors (Kachniewska 2002, pp. 20-45). Much also depends on the evaluator, his individual experience and what he considers important. Each guest has different requirements, he draws attention to other elements. What will be of great importance to one guest may not have any value for another (Dominik P., Dragon W. 2009, p.115). Therefore, it should be kept in mind that the basis for thinking about the quality of services, including hotel services, is monitoring and responding to the expectations of service buyers. Therefore, personnel management is an extremely important element of the hotel's quality management system. In services, this employee is in direct contact with the client and is able to react appropriately so that he / she is satisfied (Grobela 2016). Due to the fact that different aspects and levels of the final product quality effect may be important, there are many quality management concepts. At present, there are several formal models that can influence the shaping of high quality services in modern hotel industry. TQM, ISO standards, categorization, standardization of the object, as well as HACCP (Hazard Analysis and Critical Control Point), which has already become a mandatory system in Poland for organizations that deal in any form with agro products -food (production, transport, storage and storage, etc.). These are companies such as hotel restaurants, agritourism organizations. One of the factors determining the quality is also the recommendation. It can be personal, oral, or expressed in social media, on internet platforms or booking portals.

TQM (Total Quality Management) is a system that sets the quality of customer service at the center of your interest. It assumes the complexity of quality management, which aims to maximally involve all members of the organization at all levels. The basic assumption of TQM, according to Hans Steinbeck (Stienbeck 1998, pp.) Is to achieve customer satisfaction, ensure the company's long-term success and bring benefits to members of the organization and society. TQM, striving to meet the expectations and requirements of the client, strives to fully satisfy them. The quintessence of the principle of "quality management" are the following statements regarding the client (Turkowski 2003, p. 105):

- The client is the most important in every activity.
- It is not dependent on us. We depend on him.
- It does not disturb our work. It is her goal.
- We do not do him a favor by serving him. He is doing us a favor by coming to us.
- He is not an outsider, he is part of our organization.
- It is not a position in statistics. He is a man of flesh and blood who feels and reacts like us.
- He comes to us with his needs. Our task is to satisfy these needs.
- Deserves as much kindness and attention as we can devote to him.

TQM is based on fundamental assumptions (Witkowski, Kachniewska 2005, p. 149):

- Quality is the basic factor in obtaining customer loyalty, sales and profit.
- Each member of the organization has its client (internal and external) and knows its requirements, thanks to which quality becomes the activity of everyone in the organization.
- Quality is to prevent defects and not to create them.
- The company should be constructed in such a way that it can meet the client's expectations.

The management systems based on fulfilling the requirements of international standards of the International Organization for Standardization (ISO) 9000 series as well as environmental management systems according to the ISO 14000 series of standards belong to other best known and currently used management systems in the area of services. Systems from the ISO 9000 model, popular in the world, which are aimed at ensuring a good, unchanged level of quality, now also apply to the tourism sector, including hotel management. The ISO 9002 model is considered appropriate for the tourism and catering industry. The implementation of this model in tourism as a quality management instrument includes the collection of market information about contractors and clients, their interests, emotions, ideas, motivations, needs and financial possibilities of purchasing products. The marketing quality management system in tourism concerns designing and packaging, as well as research on raw materials, materials, quality of services, service, hygiene conditions, sanitary level, etc. (Szewczyk 2010, p. 14). Such systems bring real benefits in the area of quality improvement to both hotel facilities and their clients. From the point of view of the hotel client, the most important benefit of joining and as a result of obtaining the ISO 9000 certificate by the hotel is the certainty that you will receive a professionally made service of high quality. The task of the standards is to create a management method that allows the elimination of unnecessary and unprofitable activities in a hotel enterprise and gives the possibility to organize the organization of an enterprise thanks to the supervision over documentation and processes (Piasta 2007, p. 352). However, the implementation and maintenance of the ISO system in the hotel today is so engaging and cost-generating that very few hotel facilities decide to implement them. Admittedly, individual certificates of compliance with the ISO 9000 area standards have appeared in increasing the level of services provided, but these are marginal situations in the industry. Another of the systems affecting the quality of hotel services is their standardization. It plays a fundamental role in the work of every hotel facility.

To standardize services, hotel facilities are forced by the fact that the service is a complex process and its high quality is the most desirable element on the part of the client. The standard brings the object closer to achieving this effect, it leads to improvement of activities undertaken by the object and thus to increase the efficiency of hotel operations. Standard means a certain pattern of performance of an activity or appearance or behavior consistent with the category of a hotel and the type of activities performed in it (Bednarska, Gołembski, Markiewicz, Olszewski 2007, p. 185). Newly admitted employees will get to know the standards thanks to the textbooks or work regulations prepared for them (Górska-Warsewicz, Świstak 2009, p. 205). The hotel is standardized with many elements, among them: the use of marketing tools, employee behavior, financial operations, personnel policy, as well as clothing of employees, the appearance of rooms, dining rooms or the reception itself. Defining standards is the basis for the control of performed activities, which consist in comparing real activities, appearance and procedures to those that are considered standard (Witkowski, Kachniewska 2005, p. 142). Standardization in the hotel industry is related to categorization, which is today one of the basic ways of influencing the level of hotel services. Its task is to standardize the standards that a guest can expect in a given facility. The system reflects the object's fulfillment of various criteria, which should be determined by the object's operating standards. It houses elements such as: room equipment, gastronomy functioning, and availability of additional services. One of the forms reflecting standardization are also hotel chains. Hotels may have different areas of cooperation, but there is a certain scope of standardization - for example in the field of equipment, guest service techniques, uniformity of communication and promotion, etc. (Witkowski 2003, pp. 20-34). Categorization is a legal and administrative instrument serving to (Wszhenylewł 2001, p. 112):

- impact on the level of services (it is about forcing it to be raised or maintained by setting a minimum standard below which hotel services are unacceptable),
- protection of the client's interests by facilitating him to enforce the proper performance of services by the hotelier in accordance with the standard announced and confirmed by the decision,
- facilitating business transactions, commercial and service contacts between the hotelier and the guest without the necessity of detailed description of the facility, x facilitating the assessment of the level of services by introducing a number of standards and provisions that allow a comparison of the actual situation in the hotel and defined, generally binding criteria.

In Poland, during the years of transformation, big changes took place in tourism (Awedyk, Niezgodą 2015), the approach to cooperation of entities (Lard 2011, Wanagos, Smalec, Małachowski 2017, Sołtysik 2013), the mentality of the tourists and tourists changed. The approach to the quality of customer service and services has also changed dramatically. Social and economic changes have made us look at quality as the basic determinant of the effectiveness of business operations. The improvement process is a continuous process. The essence of quality is that the service can always be better. It seems that hotel managers notice this and constantly work on changes that improve the quality of services. In addition to socio-economic changes, attention should be paid to technical development (Sharpley, Telfer 2014). Communication is one of the most intensively changing areas. The term ICT has become widespread. Today, all activities related to the production and use of telecommunications and IT devices are considered as ICT tools. Such services are included in this scope, as well as the collection, processing, sharing of information in electronic form using digital techniques and all communication tools. Most often, this includes new media - a general description of many different forms of electronic communication (GUS). Information and communication technologies are the driving force of economic development (Watanabe, Naveed, Zhao 2015,

p. 29) and scientific and technological as well as an important source of competitive advantages (Iniesta-Bonillo, Sanchez-Fernandez, Schlesinger 2013, pp. 163-164). Dynamic changes in information and communication technologies that have occurred over the last three decades have radically affected contemporary models of economic development (Cardona, Krerschmer, Strobel 2013, pp. 109-110). In the context of the quality of hotel services, these activities become crucial. Using ICT, we can have a real impact on the development of the sphere of services, which include: people, processes (way of providing services) and material certificate (surroundings) of services. Information and communication technologies (ICT) to meet the needs of a modern, mobile and digitalizing society have an increasing impact on the functioning of business entities. Increasingly and more widely, they also enable or improve the quality of their services while maintaining cost-effectiveness. While they were initially used in marketing communication, today it is not used in all areas of hotel management and its availability. The use of ICT in the hotel industry is often also an opportunity to improve the quality of services of these enterprises. They serve there both to perform management functions and have a real impact on the quality of services offered.

### 3. METHOD AND ANALYSIS OF RESEARCH

The issue of management through quality in hotel facilities has become an inspiration to research on the use of quality management tools in hotels. The main purpose of this study is to show whether management through quality is an important decision-making direction of managers in hotels and what tools they use most. The study was carried out from July to September 2018. The method of the diagnostic survey was used, the research tool was a questionnaire which was sent electronically to the managers of the surveyed hotels. The study covered the area of the city of Gdynia, where all the facilities at the time of the study were examined as a hotel. 13 objects were examined. The structure of the examined objects is as follows: five-star hotels 1, four-star hotels 3, three-star hotels 6, two-star hotels 3. An attempt was made to answer the following questions: Do hotel managers consider quality issues as important? What quality systems are implemented? Who in the hotel deals with quality management? Are ITC tools used in the quality management process? When asked about whether quality management in a hotel is important to them, respondents could indicate one of five answers: "main", "very important", "unimportant", "no important", "I have no opinion". The respondents almost unanimously decided that quality management is one of the most important aspects of management. Most people answered that it is "very important" (61%) and "main" (31%). Only one respondent replied that he had "no opinion" (Figure 1).

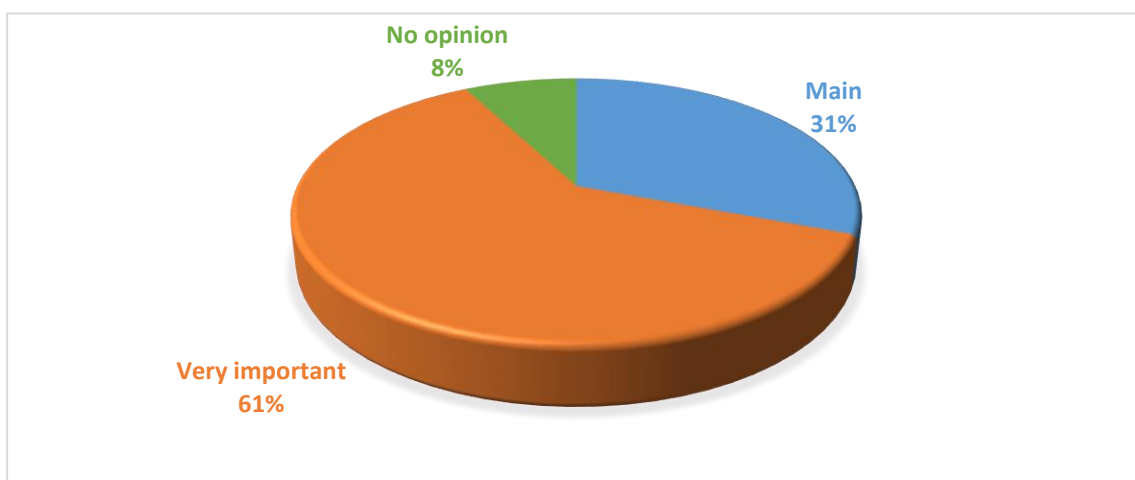

Figure 1: Issues related to quality management in the facility are main for you, very important, important or insignificant? (Own work)

The next question asked if the hotel had quality systems in place. The respondents had the choice between "HACCP Codex Alimentarius", "ISO 9001: 2000", "ISO 14001: 2004", "Other (which?)", "We do not have such systems". The most were indicated by HACCP Codex Alimentarius (61%). This means that legally binding systems are most often introduced (Figure 2).

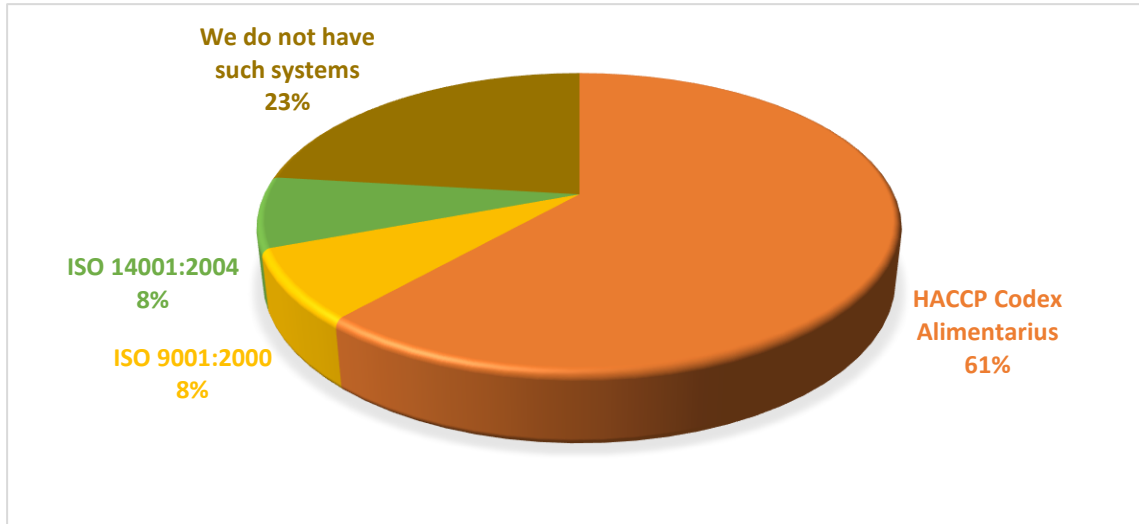

Figure 2: Which quality systems are implemented in a hotel? (Own work)

The third question concerned who is managing the quality of the hotel. Suggested answers: "Quality Supervisor", "Marketing Manager", "PR Marketing", "Property Director", "Owner", "Outside agency", "Other person (who?)", "No appointed person". Respondents indicated: "Property Director" (54%), "Marketing Manager" (15%), "Quality Supervisor" (15%). One person pointed "Owner" and one person pointed "No appointed person". Nobody pointed "Outside agency" (Figure 3).

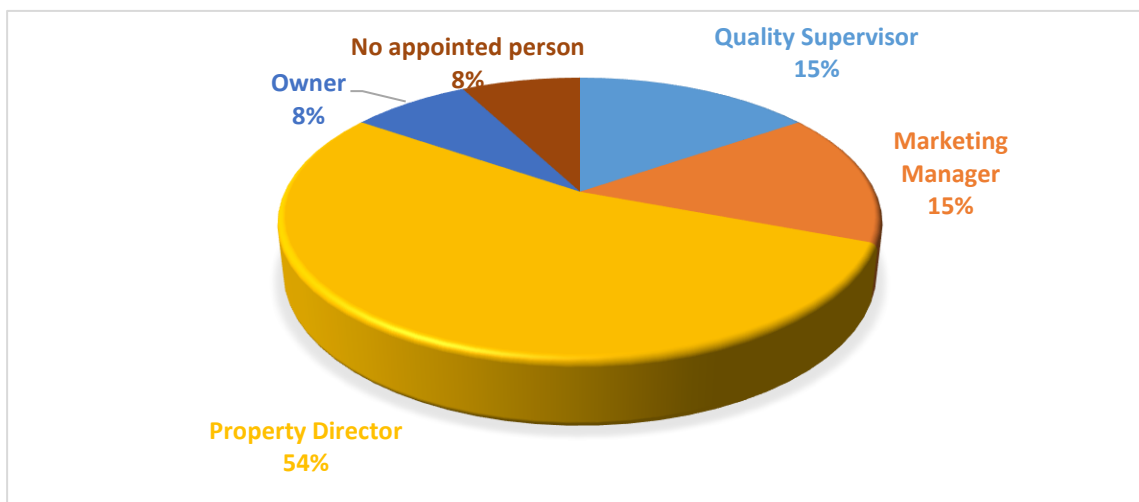

Figure 3: Who in the facility deals with quality processes? (Own work)

The next question asked about ICT tools. The idea was to show whether modern technologies and an element of quality improvement in the studied hotels. Respondents had the opportunity to choose the answer: "In large extent", "In small extent", "None". Respondents indicated: "In large extent" (31%), "In small extent" (38%) , "None" (8%). Three people did not answer (23%) (Figure 4).

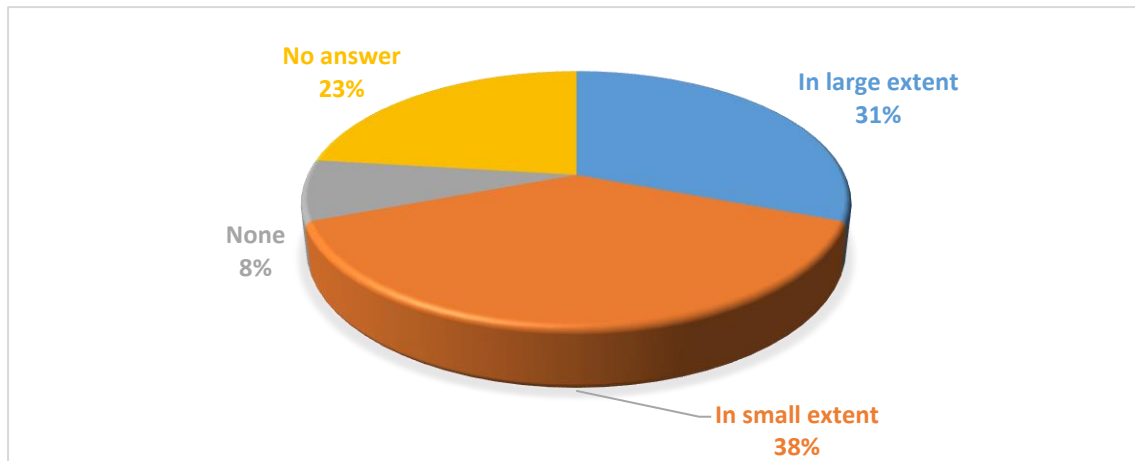

Figure 4: Do you use ICT tools in the quality management process? (Own work)

It turns out that quality management is considered one of the most important aspects by the surveyed people. However, no special quality systems are introduced, based on what is required by law or standardization resulting from categorization and belonging to the hotel chain. Modern technologies that seem to be very important in quality management processes are not an important aspect for the majority of respondents hotels.

#### 4. CONCLUSION

Analyzing literature, we can unequivocally state that quality management is one of the main directions of business management in the conditions of competition, changing customer requirements and rapid growth of technology. In hotel services this is of particular importance. There are many ways to standardize quality. Many systems have been developed to support management processes that strive for continuous improvement of services. On the basis of the theoretical inspiration the problem of quality management in hotel services, a survey was carried out in all hotel facilities in Gdynia. The analysis shows that the vast majority of respondents consider quality to be an important sphere of hotel operation. However, few hotels implement quality systems, in addition to those required by top-down regulations (eg HACCP Codex Alimentarius in gastronomy). ITC tools are known by the respondents, but relatively little use in quality management.

#### LITERATURE:

1. Awedyk, M., Niezgoda, A. (2015). New opportunities for future tourism after 25 years of political and socioeconomic transformation - foresight in Poland's tourism planning. *Journal of Tourism Futures*, 2015 (Vol. 2, Issue 2), pp. 137-154.
2. Bednarska M., Gołembski G., Markiewicz E. (2007). M.Olszewski, *Przedsiębiorstwo turystyczne. Ujęcie statyczne i dynamiczne*. Warszawa: PWE.
3. Cardona M., Kerschmer T., Strobel T. (2013). ICT and productivity: conclusions from the empirical literature. *Information Economics and Policy*. 2013 (Vol. 25, no. 3), pp. 109-125.
4. Dominik P., Drogoń W. (2009). *Organizacja przedsiębiorstwa hotelarskiego*, Warszawa: Zakład Wydawniczy Druk – Tur.
5. Górska-Warsewicz H., Świstak E. (2009), *Funkcjonowanie przedsiębiorstwa hotelarskiego*. Warszawa: SGGW.
6. Grobelna A. (2016). Challenge stressors in the hospitality industry and their impact on employees' performance. Pinzaru F., Bratianu C. (eds.). *12th European Conference on Management, Leadership And Governance ECM. Academic Conferences and Publishing International Limited, UK. Conference Proceedings*, pp. 71-79.



7. GUS – Główny Urząd Statystyczny (Central Statistical Office), *Rozporządzenie Prezesa Rady Ministrów z dnia 1 kwietnia 2011 r. w sprawie określenia wzorów formularzy sprawozdawczych, objaśnień co do sposobu ich wypełniania oraz wzorów kwestionariuszy i ankiet statystycznych stosowanych w badaniach statystycznych ustalonych w programie badań statystycznych statystyki publicznej*. Dz. U. Nr 83 poz. 453
8. Iniesta-Bonillo M. A., Sanchez-Fernandez R., Schlesinger W. (2013). Investigating factors that influence on ICT usage in higher education: a descriptive analysis, *International Review on Public and Nonprofit Marketing*. 2013 (Vol. 10, no. 2) pp. 163-174.
9. Jędrzejczyk I. (2003) Jakość jako czynnik budowy przewagi konkurencyjnej na rynku turystycznym. *Kierunki badań naukowych w turystyce*. Warszawa: AE Poznań, PWN, pp. 25-42.
10. Kachniewska M. (2002). *Zarządzanie jakością usług turystycznych*. Warszawa: Difin.
11. Małachowski K. (2015). Dylematy konkurencyjności regionalnej - zarys problemu. *Zeszyty Naukowe Uniwersytetu Szczecińskiego. Ekonomiczne Problemy Usług*. 2015 (Vol 118), pp. 225-235.
12. Martin W.B. (2006), *Zarządzanie jakością obsługi w restauracjach i hotelach*, Kraków: Oficyna Wydawnicza Wolters Kluwer.
13. Ostasiewicz W. (ed.) (2004). *Ocena i analiza jakości życia*. Wrocław: Wydawnictwo Akademii Ekonomicznej im. Oskara Langego we Wrocławiu.
14. Piasta J. (2007). *Marketing w hotelarstwie, Podręcznik praktyczny*. Warszawa: Wydawnictwo Jacek Piasta – Doradztwo.
15. Rosa G., Ostrowska I., Słupińska K., Gracz L. (2018). The influence of the type of customer (individual vs institutional) on the principles of written communication of a large organization, *Economic and Social Development 33rd International Scientific Conference on Economic and Social Development – Managerial Issues in Modern Business*, Book of Proceedings, Warsaw, 26-27 September 2018, pp. 351-360.
16. Sharpley R., Telfer D.J. (2014). *Tourism and Development: Concepts and Issues*, Bristol: Channel View Publications.
17. Smalec A. (2011). Rola komunikacji w rozwoju koncepcji partnerstwa w regionach. *Zeszyty Naukowe Uniwersytetu Szczecińskiego. Ekonomiczne Problemy Usług*. 2011 (Vol. 75), pp. 489-502.
18. Sołtysik M. (2013). Uwarunkowania i modele międzysektorowej polityki turystycznej w podmiejskich gminach Legnicy i Wrocławia [Determinants and models of inter-sector tourism policy in the suburban municipalities of Legnica and Wrocław], Wrocław: *Studia i monografie Akademii Wychowania Fizycznego we Wrocławiu*. (2013) No 116 *Statistical Yearbook of Gdynia City*, Statistical Office in Gdańsk, Retrieved (15.05.2018 from file:///C:/Users/Asus-R558U/Downloads/RocznikGdyni2016.pdf).
19. Steibeck H.H. (1998). *Total Quality Management - Kompleksowe Zarządzanie Jakością - doświadczenia praktyczne z IBM Niemcy*. Warszawa: Agencja Wydawnicza Placet.
20. Studzieniecki, T., Soares. J., R. (2017). Interregional tourism cooperation: A Europe case study. *HOLOS*. Ano 33. Vol. 04, pp. 135-148.
21. Szewczyk I. (2010). Znaczenie jakości w przedsiębiorstwie hotelarskim. *Zeszyty Akademii Techniczno-Humanistycznej w Bielsku Białej*, 2010 (Vol. 1) pp. 12-25.
22. Turkowski M. (2003). *Marketing usług hotelarskich*. Warszawa: PWE.
23. *Ustawa z dnia 29 sierpnia 1997 r. o usługach turystycznych*, rozdz. 5 (Dz.U.2017.0.1553).
24. Urbanyi-Popiołek, I. (2014). Cities Cruise industry in the City of Gdynia, the implications for sustainable logistic services and spatial development. *1st International Conference Green Cities 2014 - Green Logistics for Greener*. Procedia - Social and Behavioral Sciences. pp. 342-350.

25. Wanagos M. (2010). Rola działań marketingowych samorządów lokalnych w rozwoju turystyki na przykładzie województwa pomorskiego, *Prace Naukowe Uniwersytetu we Wrocławiu*, 2010 (Vol. 109), pp. 109-118.
26. Wanagos M., Smalec A., Małachowski K. (2017). Local government activities relating to local entrepreneurship by tourism entities in the Pomeranian Voivodeship. *20th International Colloquium on Regional Sciences. Conference Proceedings*. pp. 700-706.
27. Watanabe Ch., Naveed K., Zhao W. (2015). New paradigm of ICT productivity – increasing role of un- -captured GDP and growing anger consumers. *Technology in Society*. 2015 (Vol. 41), pp. 21-44.
28. Witkowski Cz. (2003). *Międzynarodowe systemy hotelowe w Polsce. Część II*. Warszawa: Wyższa Szkoła Ekonomiczna.
29. Witkowski Cz., Kachniewska M. (2005). *Hotelarstwo w gospodarce turystycznej. Hotelarstwo część III*. Warszawa: Wydawnictwo PWN.
30. Wszendybył E. (2001), Kategoryzacja miarą jakości usług hotelowych. *Zarządzanie rozwojem organizacji jakość procesów i produktów*, Sosnowiec: Wyd. Wyższa Szkoła Zarządzania i Marketingu, pp. 110-122.
31. Zabielska I., Zielińska-Szczepkowska J. (2017). Local border traffic as a platform for the development of Border Cities. *10th International Conference Vilnius Gediminas Technical University. Conference Proceedings*, pp. 1-9.

## COOPERATION OF ENTITIES IN THE MARKET OF REGIONAL TOURIST PRODUCTS

**Marzena Wanagos**

*Gdynia Maritime University in Gdynia, Poland  
m.wanagos@wpit.am.gdynia.pl*

**Barbara Marciszewska**

*Gdynia Maritime University in Gdynia, Poland  
b.marciszewska@wpit.am.gdynia.pl*

### **ABSTRACT**

*The regional tourist product is usually developed by many entities. Its unique feature is complexity. Individual elements form one whole, although they are managed by different entities. It means that the regional tourist product consists of many elements which are complementary to one another. Cooperation of entities developing the regional tourist product is particularly important, and it is often even a prerequisite for such products. Regional tourism policy is crucial as it should focus on enhancing motivation for cooperation among entities in the region and outside it. Such cooperation affects the scope, structure, quality as well as the availability and image of regional tourist products, among others, and therefore the region's competitiveness. The aim of this paper is to present the unique nature of regional tourist products, where the development of such products is determined by cooperation. This paper also seeks to show the diversity of regional tourist products, depending on the entities involved and their objectives. Research has been conducted in order to identify the motives for cooperation, to show the level of willingness and satisfaction from such cooperation and the awareness of undertaking joint actions. The representatives of the entities participating in the development of joint regional products were surveyed. A diagnostic survey was carried out using questionnaires. A sample of 643 various entities (local governments, commercial entities, nonprofit tourism organisations) were surveyed during 2013-2016 in Poland. The problem analysis has shown that regional tourist products are particularly difficult to develop. Their scope, structure, quality as well as availability and image depend on a range of factors that result from cooperation of many entities. They are the basis for the region's tourism attractiveness and competitiveness. The results of the research have shown that entities are willing to cooperate provided that the product achieves their individual objectives and there is a leading entity which motivates them properly to take action. The research has also shown that entities prefer to cooperate with the same or similar type of entities; for example, a local government with other local governments, commercial entities with other commercial entities. It is much more difficult to establish and implement cooperation with entities of different nature. Nonprofit organisations usually manage to do that. Also, it must be noted that the awareness that cooperation is necessary for developing regional tourist products is very high among the surveyed entities.*

**Keywords:** *cooperation, regional product, tourism*

### **1. INTRODUCTION**

This paper discusses the issues related to cooperation of entities in the tourist market. Thanks to such cooperation, regional tourist products can be developed. Each of these entities can contribute a new value to the product, a value which will ultimately determine the shape of the product. The unique nature of regional products, which results from the fact that they are developed by various entities with different scopes and objectives, allows for the assumption that cooperation is one of the basic issues to ponder over in this matter.

The aim of this paper was to identify the core of cooperation on regional tourist products and to identify the willingness of certain groups of entities to cooperate as well as to evaluate the satisfaction from the cooperation between certain types of creators of regional products. The research described in this paper is an effect of several years' work and analysis of many entities and situations. It focused mainly on the relations between entities in the regional tourist market, their contribution to the development and innovativeness of products and the motives for conducting activities in this scope. The research was carried out across Poland. A diagnostic survey was conducted using questionnaires. Three different questionnaires were used; they were addressed to representatives of various types of entities (companies, local government units and nonprofit organisations). The questionnaires included questions which were the same for all surveyed entities. Six hundred forty-three entities in total were covered by the research carried out during 2013-2016. The entities were selected purposively: we chose those which participated in various types of regional product-related initiatives and expressed their willingness to take part in the research. For the purposes of this work, only some part of the results was used, i.e. the results relating to the willingness to establish cooperation, the assessment of cooperation, and the assessment of satisfaction from the cooperation among individual groups of entities

## **2. THE SPECIFICITY OF REGIONAL TOURISM PRODUCTS IN THE CONTEXT OF THE COOPERATION OF ENTITIES**

The regional tourist product is developed by many entities. These entities often act to achieve different goals and have different legal forms. When trying to outline the types of such entities in general, one can name (Wanagos 2009, pp 587-596; Studzieniecki, Korneevets 2016, pp. 1135-1142):

- local governments whose main objective is the social and economic development of an entity, including social and economic infrastructure, including the network of media, environment protection and sport and recreational equipment, road networks as well as culture, education, etc.;
- companies whose main objective is to gain benefits from their own activity; they provide services for tourists directly, e.g. accommodation, catering, cultural, recreational, educational services, etc.;
- non-commercial entities focused on social activities or supporting and developmental activities; they are usually established by individuals or institutions involved in a specific area of life such as culture, sport, the environment, or directly in tourism (Kizielewicz, Skrzyszewska 2016);
- residents, who are the basic initiators of the tourist product as well as the social climate and hospitality related to this product through their attitudes, creativity and work.

*Figure following on the next page*

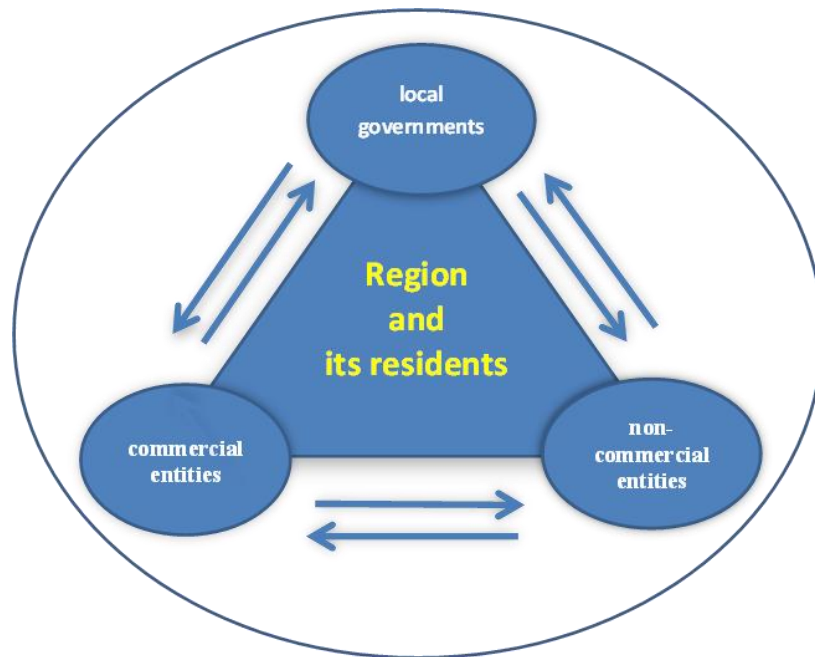

Figure 1: Regional entities (Own work)

Different objectives and activities of individual entities cause certain difficulties in developing regional products; nevertheless, it allows for a complementary approach. Everything that relates to a certain area and constitutes its offer is a product of that area. This is usually a very complex value which consists of many elements. It includes elements which are beyond human control (e.g. environmental conditions) and elements which are shaped with full awareness by using the market situation and previous analyses (e.g. the provided services). If the consumer of such products is a tourist, the product becomes a tourist product, whether or not it was created specially for tourists. In literature, a product which is connected with a certain area is named a megaproduct, and its elements which can be independent products in the market are called subproducts (Szromnik 2010, pp. 111-116). All difficulties in developing territorial products result from the features of such products. These features are (Florek 2006, p. 80):

- intangibility of the territorial product as a whole;
- it is impossible to compare megaproducts directly in the temporal and spatial aspect;
- a big diversity and different durability of subproducts within a megaproduct;
- a very high level of complementarity of subproducts within a megaproduct;
- high internal substitutability of the megaproduct.

Due to the complementarity and substitutability of the product, cross-sectoral cooperation is also important (Sołtysik 2013, pp. 8-25). From an organisational perspective, any region as a complex system represented by many entities can provide special opportunities for developing relations and connections between institutions (Studzieniecki 2016, pp. 235-241). It creates many opportunities to direct the development of products due to the diverse structure of the potential of nature, cultural heritage as well as the human potential (Rosa, Ostrowska, Słupińska, Gracz 2018, pp. 351-360). This is important regardless of the destination Kotylak, Egri 2014, pp.73-80). As a result of cooperation, an added value is created, and regional stakeholders become the beneficiaries of this value (Studzieniecki, Soares 2017, pp. 135-148; Małachowski 2015, pp. 225-235). The entire region, with connected complementary elements, creates a value which takes a specific, unique and unrepeatable character during a tourist's stay in an area. The cooperation of regional entities includes mainly:

- continuous contact between entities (Smalec 2011, pp. 489-502);

- establishment of relations between entities (contacts, agreements, etc.);
- development of a joint offer (functional and organisational planning, etc.);
- sales organisation (as a package or as individual elements);
- settlement of the effects of cooperation (financially or statistically, by monitoring the product, etc.).

Each entity fulfils a specific function. These functions are determined by the legal form of entities and the roles taken in accordance with cooperation arrangements. Individual entities are responsible for different spheres of regional tourist products. Activities conducted by authorities and employees of local governments include mainly long-term planning, spatial planning, monitoring changes in the occurring phenomena and processes, initiating and coordinating activities, the quality of values, infrastructure, service, etc. in a territorial unit (Sharples, Telfer 2014, pp. 12-60). Often the activities of local government support other actors and motivate them (Wanagos, Smalec, Małachowski, 2017, pp. 700-706). Activities conducted by commercial entities and other organisations in an area include developing and selling specific subproducts of the area, often affecting the quality and the elements of services and goods which are at the company's disposal (Gursoy, Saayman, Sotiriadis (ed.) 2015, pp. 34-51). Such activities may include propagating ideas related to, e.g., ecology, equality, family, etc. All groups of entities are important in the process of developing a regional tourist product. Each entity fulfils a different function and affects the regional tourist product in a different manner. In the region, there is usually one of the two types of regional tourist products: a linear tourist product or a chain tourist product. Examples of the linear tourist product are: canoe rallies, "The Beskid Trail", "The Trail of the Eagles' Nests", or a pilgrimage, e.g. to Częstochowa. They are services connected with one another thematically, values adjusted to leisure activities, including those with signposts. Chain products are based on cooperation of many entities in a specific spatial extent; they form one whole in terms of a thematic or organisational offer, but not necessarily border on each other, for example "Solidarity in the history of Poland and Europe" or "Amber in Pomerania". Regional tourist products can be developed by different structures, both formal and informal (Zielińska-Szczepkowska 2017, pp. 109-139). Only some local and regional tourism organisations conduct this task comprehensively. In tourism organisations, activities relating to tourism promotion and information predominate. In rural areas cooperation may take the form of Local Action Groups, but such products must be based on regional structures. The allocation of tasks, financial engineering and the durability of the effects of cooperation may also cause a problem. It is difficult to burden one entity with many tasks, which creates problems with finding, e.g., a product's leader. An important and difficult task is also the commercialisation of products, for which companies are responsible. In Eastern Europe, there is a specific mentality of the population that reflects caution in cooperation (Jahn 2001, pp. 11-26, Awedyk, Niezgodna 2015, pp. 137-154, Wollmann, Lankina 2003, pp. 91-122 ). The diversity of regional tourist products and the entities contributing to the shape of such products is a very complex issue. The product leader connects and coordinates activities with its partners. Partners can be passive (they only use some effect of cooperation, without their own contribution) or active (they become involved in the development of the product). Certain entities can fulfil supporting functions in the development of a regional tourist product, for example marketing agencies, printing companies, etc. (Selin 1999, pp. 260-273). First, one needs to ask whether there will be entities willing to cooperate with one another and whether they will be satisfied from such cooperation. This paper has shown that the problem is very broad and can be analysed in many ways. This analysis seeks to give answers to the elementary questions: do entities which have different forms and objectives want to cooperate with one another in order to create a joint regional product, and how do they assess the cooperation that has already been established?

### 3. METHOD AND ANALYSIS OF RESEARCH

This research sought to assess the cooperation between entities which establish formal and informal relations in order to achieve effects in the form of a joint regional product. The main problem was to identify the elements of cooperation that are the distinctive features of certain groups of entities. Do certain groups of entities (companies, local governments, nonprofit organisations) perceive the cooperation with other entities in the same manner? Do the motives for establishing such cooperation differ in these groups? Why do the entities developing regional products establish cooperation, and are they satisfied with the effects of such cooperation? The research gave answers to the following questions, among others: Which entities prefer to cooperate with each other and how do they assess this cooperation? Why did these entities establish cooperation? Are the benefits of such cooperation satisfying? The group of entities which already established cooperation in order to develop regional tourist products was selected purposively. Six hundred forty-three entities were surveyed in total ( $n=643$ ). The respondents represented:

- companies (502 entities represented activities strictly related to tourism such as hospitality management, catering, travel agencies, passenger transport services, including entities which provide services for tourists but are not related to the tourism industry such as commerce, recreational services, marketing services, etc.);
- local governments (83 entities at all three levels);
- nonprofit organisations (63 entities related to tourism, including local and regional tourism organisations).

The following hypotheses were constructed for this research: "The entities are willing to cooperate with one another to develop regional tourist products", "The awareness of cooperation is very high", "The entities act mainly for the common interest, enhancing the region's competitiveness". Respondents were selected purposively. Only the entities which established cooperation earlier in order to develop regional tourist products were surveyed. The questionnaires were given to respondents directly, during meetings and trainings in which they participated as part of their cooperation on the development of a product. The refusal rate was between 1% and 3%. The method of this research was a diagnostic survey. It was carried out by using questionnaires. Three questionnaires were drawn up. They included a part which was identical for all types of entities and a part dedicated to each of the three types of entities individually, with different questions. The questionnaires contained 30 questions, among which were open- and closed-ended questions, with single or multiple choice. For the purpose of this analysis, only the questions from the common part were selected, i.e. nine open-ended and closed-ended questions with single and multiple choice. Some questions were semi-closed as the respondent could add a comment to his or her answer. The following elements of the survey were analysed: motives for establishing cooperation, assessment of current effects, form of cooperation and type of entities preferred by the entities, factors conditioning the success of the established cooperation. All questions were in the common part of the questionnaires. This analysis does not include the questions addressed to specific groups of entities. The questionnaires contained the demographics, which enabled to describe the surveyed group by legal form, direction of activities and localisation, among others. The methods of descriptive statistics were used to analyse the collected data. Each entity achieves its objectives through cooperation. This cooperation is sometimes necessary to achieve such objectives. All the surveyed entities declared that cooperation is necessary and allows them to create additional values which they provide in the market. They could name up to three motives in the open-ended question: "Why do they establish cooperation?" The most common answers were: to use their own potential (35%), to enhance the satisfaction of tourists (30%), to implement their statutory goals (24%), to increase organisational and financial capacities (22%), to increase the

competitiveness of their offers (18%), to enhance a product's quality (15%), to extend the product (14%), to make the product more attractive (12%), to use and develop good relations with the community (8%). This shows that cooperation is treated as a tool for achieving an entity's objectives. The question about the main barriers to developing common products was open-ended. Among the main obstacles to good cooperation were: no leadership (if cooperation involved many entities) (30%), lack of common ideas (25%), lack of funds (25%), lack of a long-term concept (10%) due to changes in the personnel in individual organisations, etc. The answers prove that the biggest obstacle to developing common products is leadership. Generally, in such cases leadership always focuses on a specific person, even though it involves a specific organisation. The development of a product is a lengthy process, therefore the concept of changes, financing and decision-making options cause many problems. It turns out that the entities are willing to cooperate with one another (as many as 99% of respondents confirmed this thesis). The next question concerned with whom the entities prefer to cooperate. The surveyed entities were asked to assign numbers from 1 to 3 respectively, where 1 meant they want to cooperate the most, and 3 – the least. Companies prefer to cooperate with other companies (90% of the surveyed companies marked it as "1"); they are relatively mistrustful of nonprofit entities (answer "2" predominated, 51%); they are least willing to cooperate with local governments (answer "3" predominated in as many as 63% of cases). In the comments, the representatives of companies often emphasised that cooperation with local government involves funds for the project. In turn, the representatives of local governments prefer to cooperate with nonprofit organisations (84% chose answer "1") and often give them tasks to complete. It is quite obvious that local governments are often the initiators of nonprofit organisations. They fund them in order to develop and promote products through such organisations. It mainly concerns local and regional tourism organisations. Cooperation between local governments is also determined by political reasons which can be crucial in some cases. Local governments prefer to cooperate with companies the least (78% chose answer "3"), and assess the cooperation with other local governments rather high, although answer "2" predominates (91%). Nonprofit organisations prefer to establish cooperation with other nonprofit organisations (66% indicated "1"), next with local governments (72% indicated "2"), and the least with companies (56% indicated "3"). A scale from 1 to 5 points was used to assess the already established cooperation, where three types of entities were identified. The results of the assessment of cooperation by type of entities are as follows: the representatives of business entities rated the cooperation business entity – business entity the highest (4 points on average), next business entity – local government (2.5 points on average), and business entity – nonprofit organisations the lowest (below 2 points). In turn the representatives of local governments rated the cooperation with local governments the highest (3 points on average), slightly lower with nonprofit organisations (2.5 points on average), and the lowest with companies (2 points on average). Nonprofit organisations rated the cooperation as follows: with local governments (4.5 points on average), with nonprofit organisations (3.5 points on average), with companies (3 points on average). When analysing the satisfaction of individual entities from the effects of cooperation, it must be concluded that it is generally very low. On a scale from 1 to 10, the overall assessment of satisfaction was equal to 4 points. Satisfaction exceeded 8 points only in 12% of answers, and it was given no more than 3 points in 38% of answers. Nevertheless, it must be concluded that all entities expressed their willingness to cooperate and agreed with the statement that all entities have to cooperate in order to develop a regional tourist product, both companies, nonprofit organisations and local governments.

#### **4. CONCLUSION**

Summing up, it must be concluded that entities are willing to cooperate provided that the product achieves their objectives and there is a leading entity which motivates them properly



to take action. The research has also shown that entities prefer to cooperate with the same or similar type of entities; for example, a local government with other local governments, commercial entities with other commercial entities. It is much more difficult to establish and implement cooperation with entities of different nature. Nonprofit organisations usually manage to do that. The entities expressed their willingness and need to cooperate, although the level of their satisfaction from the effects of cooperation is low. The activities which are taken do not always meet their expectations; however, they obviously see a chance for self-development in such cooperation. Unfortunately, the survey has not confirmed the hypothesis that entities act in order to enhance the region's competitiveness. Their activities focus on achieving their own goals. Also, it must be noted that the awareness that cooperation is necessary is very high among the surveyed entities. It gives hope for more frequent activities and further development of regional tourist products.

#### LITERATURE:

1. Awedyk, M., Niezgodna, A. (2015). New opportunities for future tourism after 25 years of political and socioeconomic transformation - foresight in Poland's tourism planning. *Journal of Tourism Futures*, 2015 (Vol. 2, Issue 2), pp. 137-154.
2. Florek, M. (2006). *Podstawy marketingu terytorialnego*. Poznań: Wyd. AE w Poznaniu.
3. Gursoy D., Saayman M., Sotiriadis M.D. (ed.), (2015) *Collaboration in Tourism Businesses and Destinations: A Handbook*, Emerald Group Publishing: Bingley.
4. John P. (2001). *Local Governance in Western Europe*. London: Thousand Oaks.
5. Kizielewicz J., Skrzyszewska K. (2016). The role of non-governmental organizations in the field of sustainable development of cruise ship tourism. In: Z. Primorac, C. Bussoli, N. Recker (eds.), *16th International Scientific Conference on Economic and Social Development*. Conference Proceedings. pp. 546-556.
6. Kotylak S., Egri M. (2014). Comparative analysis of cultural and creative industries in selected cities in Turkey and Poland. *Market in the modern economy. Management – processes*. Bratislava: Kartprint, pp. 73-80.
7. Małachowski K. (2015). Dylematy konkurencyjności regionalnej - zarys problemu. *Zeszyty Naukowe Uniwersytetu Szczecińskiego. Ekonomiczne Problemy Usług*. 2015 (Vol 118), pp. 225-235.
8. Rosa G., Ostrowska I., Słupińska K., Gracz L. (2018). The influence of the type of customer (individual vs institutional) on the principles of written communication of a large organization, *Economic and Social Development 33rd International Scientific Conference on Economic and Social Development – Managerial Issues in Modern Business*, Book of Proceedings, Warsaw, 26-27 September 2018, pp. 351-360.
9. Selin S., (1999). Developing typology of sustainable tourism partnerships, *Journal of Sustainable Tourism*, 1999 (Vol. 7, no. 3/4), pp. 260-273.
10. Sharpley R., Telfer D.J. (2014), *Tourism and Development: Concepts and Issues*, Bristol: Channel View Publications.
11. Smalec A. (2011). Rola komunikacji w rozwoju koncepcji partnerstwa w regionach. *Zeszyty Naukowe Uniwersytetu Szczecińskiego. Ekonomiczne Problemy Usług*. 2011 (Vol. 75), pp. 489-502.
12. Sołtysik M. (2013). Uwarunkowania i modele międzysektorowej polityki turystycznej w podmiejskich gminach Legnicy i Wrocławia [Determinants and models of inter-sector tourism policy in the suburban municipalities of Legnica and Wrocław], Wrocław: *Studia i monografie Akademii Wychowania Fizycznego we Wrocławiu*. (2013) No 116.

13. Studzieniecki, T., Korneevets, V. (2016). The role of the European Neighborhood Policy instrument in the tourist development of the Lithuanian - Polish - Russian borderland. In: Klímová, V., Žitek, V. (eds.) *19th International Colloquium on Regional Sciences. Conference Proceedings*. pp. 1135-1143.
14. Studzieniecki, T. (2016). The development of cross-border cooperation in an EU macroregion - a case study of the Baltic Sea Region. *Procedia Economics and Finance*, 2016 (Vol. 39), pp. 235-241.
15. Studzieniecki, T., Soares. J., R., R. (2017). Interregional tourism cooperation: A Europe case study. *HOLOS*. Ano 33. Vol. 04, pp. 135-148.
16. Szromnik A. (2010). *Marketing terytorialny. Miasto i region na rynku*, Warszawa: Oficyna Wolters Kluwer Business.
17. Wanagos M. (2009). Współpraca w kształtowaniu regionalnych produktów turystycznych. *Zeszyty Naukowe Uniwersytetu Szczecińskiego - Ekonomiczne Problemy Usług*. 2009 (Vol. 41), pp. 587-596.
18. Wanagos M., Smalec A., Małachowski K. (2017). Local government activities relating to local entrepreneurship by tourism entities in the Pomeranian Voivodeship. *20th International Colloquium on Regional Sciences. Conference Proceedings*. pp. 700-706.
19. Zielińska-Szczepkowska J. (2017). Kłustry jako stymulatory konkurencyjności regionów turystycznych – przykład województwa warmińsko-mazurskiego. *Prace i Studia Geograficzne*, 2017 (62 /3), pp. 109-139.
20. Wollmann H., Lankina T. (2003), Local Government in Poland and Hungary: from post-communist reform towards EU accession, *Urban Research International, Local Democracy in Post-Communist Europe*. 2003 (Vol. 2), pp. 91-122.

## EVALUATION OF EU GRANT SCHEME USING WEBSITE PERFORMANCE MEASURES

**Lukasz Konopielko**

*Łazarski University, Poland  
lukasz.konopielko@lazarski.pl*

**Jacek Wytrebowicz**

*Institute of Computer Science,  
Warsaw University of Technology, Poland  
J.Wytrebowicz@ii.pw.edu.pl*

### **ABSTRACT**

*This paper investigates the applicability of diversified indicators to measure the performance of newly created websites, backed by EU financial support in Poland. A full sample of 2730 projects focused on e-services creation is analysed, with a use of various metrics focused on visibility, popularity and valuation. Two rounds of data collection were conducted in the period of 2015-2018, accounting for dynamic effects. Quality indicators of the websites in sample deteriorates quickly and there is no significant difference between subsequent calls rounds that took place over 2008-2013 period. Therefore negative conclusions on sustainability of projects as well as on efficiency of public support for e-services are drawn.*

**Keywords:** *EU funds, Internet, websites, performance*

### **1. INTRODUCTION**

European funds are financial aid for the developing regions of European Union (EU) and for the enterprises located within these economies. Over a period of 2007-2013 more than EUR 107.3 bn was invested in various EU sponsored projects in Poland, where EUR 85.5 bn was contributed by EU and amounted to circa 5% of the GDP per year. Similar amounts (i.e. EUR 82.5 bn from EU) are budgeted for Poland within another 2014-2020 financial perspective. Out of that sum around EUR 45 bn will be distributed through country-wide programmes and the remaining sum, through 16 regional programmes. Each programme is built as to assess the situation and recommend certain initiatives that can be taken in order to improve it. These recommendations themselves become a detailed grant programme. Great attention is paid to innovativeness of enterprises in both financial perspectives – especially in the area widely defined as e-business and provision of services via the Internet, including infrastructure for Internet delivery. Introduction of innovative products and services is connected to technological changes, globalization and other factors. Innovativeness of entities is expected to positively affect their growth and the growth of regions as well as promote competitiveness across economy. This paper concentrates on the results of grants intended for creation or development of innovative entities in Poland and granted during the 2007-2013 period, within the Operational Programme Innovative Economy (OP IE) initiative, and particularly on 8.1 Measure, which was designed to support the development of e-services by developing websites focused on delivery of these services. The OP IE was to provide financial support of EUR 10.18 bn, where part of the total came from the budget of the state (EUR 1.53 bn) and the rest (EUR 8.65 bn) from the European Regional Development Fund (ERDF). The main goal of the Programme was to improve innovativeness of the Polish economy and Polish enterprises, and therefore the support was directed at projects which aimed at establishment and development of innovative firms. The Programme concentrated on individual enterprises rather than on whole regions.

The main goal of improving innovativeness of the Polish economy was expected to be achieved through the fulfilment of specific objectives. The six main objectives were as follows:

- the improvement of innovativeness of entities,
- the improvement of competitiveness of Polish science,
- the reinforcement of value of science within economy,
- the organisation of new and the improvement of existing workplaces,
- the dissemination of Polish innovative products all over the world,
- the increase in the usage of Information and Communication Technologies (ICTs).

The last objective was directly addressed by the above mentioned 8.1 Measure and its purpose was to stimulate the development of electronic economy by encouraging the creation of new e-services. The target group was micro and small entrepreneurs. Until the end of 2014, 13 calls for projects had been made, attracting, in total, 15,240 applications, out of which 2,730 agreements were signed, which means that the rate of success measured in terms of application to grant ratio was 17.21%, while in terms of value awarded to value requested – 18.56% (Moroz, 2014). The amount of awarded funding exceeded PLN 1.495 bn (equivalent of around EUR 360 mln), while an individual project could receive up to 85% of eligible investment. The grants were only awarded to new companies offering e-services via websites and less frequently via software applications. This allows for a relatively simple comparative perspective for the assessment of the supported companies' development by directly monitoring the website set. Unlike in many development schemes, where publicly backed projects contribute only to a fraction of the company's revenue and activities, here, an assumption that the project value actually equals the company's value can be applied. This simplifies the measurement process, and allows for the analysis of the websites' performance to be a proxy of the entire project's performance. This paper explores the effects of the 8.1 Measure using data from two rounds of research. The first one, just after measure termination in 2015 and another one after almost 3 years (2018). Such time frame allows for the elimination of unsuccessful projects but also for the drawing of conclusions both on the website survival factors and on the determinants of its success, thus, on the effectiveness of the grant scheme as a whole. Thus research questions are as follows: What is the percentage of the created e-services that succeeded in comparison to the ones that failed and how does the passage of time influence their performance? What is the relation between the value of public funding and the final product of the scheme, i.e. numerous e-services built by the beneficiaries of the scheme? And finally: How long will the visible results of the grant scheme last?

## **2. METHODOLOGY AND DATA DISCUSSION**

This paper assumes that e-services performance can be measured using website traffic statistics and different metrics that can be applied to a numerous set of web pages. Even though the available measures of e-services (i.e. number of website visits, website ranks, consumer loyalty, number of accounts, etc.) cannot be directly related to company performance, the assumption that a bigger popularity of e-service implies bigger income holds when we compare e-services of the same kind. Moreover, lack of activity or eventually disappearance of the website must be regarded as a definite end of e-service activity in the business formula supported by subsidy. However, research related to the relation between business performance and website characteristics is relatively limited. Competitive intelligence factors of websites such as age, PageRank, number of the independent IP addresses that have visited the website in one day, number of webpages that have been visited in one day, reflecting the user retainability of a given website, backlinks, response time and search engine visibility have been analysed by Hu<sub>SEP</sub> and Zhu (2013). Their paper concludes that above-listed website factors should be an important consideration in an analysis of a company's competitive position.

Gneiser et al. (2012) established a model for the valuation of online social networks. Composite measure is based on the PageRank algorithm to quantify users' interconnectedness. The model is employed for a valuation of a representative service. Arduini and Zanfei (2014) analyse the research of public e-services over the past decade. Generally, the body of research for this period is more quantitative than qualitative. In their sample data treatment-collection techniques include web-search, telephone interviews, face-to-face interviews and questionnaires, with web-search being the most frequently used one (over 33%). However, the authors do not report what exact web-search techniques were mostly employed and which measures were gathered. Similar approach, although more qualitative, is presented by Czarnowski and Szyda (2018) who provide a catalogue of proposed determinants to get the measure of online commercial services qualities in technological dimension, while Chmielarz and Parys (2018) apply above mentioned telephone interviews techniques to investigate factors affecting electronic business in recent years. Santos (2013) identifies three main aspects of cyber assets valuation: intellectual property, domain name and website and customer's list. A distinction between the discrete and the collective methods of valuing cyber assets is made. The discrete method attempts to separate each asset of an on-line business and to value it independently, while in the collective method, the total intangible value of the business is quantified as aggregate. Differences in achieved values may arise, as value calculated in line with collective method does not equal the amount derived on the basis of an individual calculation, i.e., the discrete method. An interesting approach to measuring websites' functions as a proxy for economic development was taken by Jakimowicz and Reczkowski (2018). They applied the so called four colour theorem – a method for identifying regional poles and turnpikes of growth to the evaluation of the functionality of websites run by public administration municipal offices in the Polish province of Warmia and Mazury. Each municipality was marked with a colour corresponding to the quality class of the website run by the state administration unit operating in a given area in order to identify the development patterns. Data were collected in two rounds (2009 and 2012) in order to add dynamic dimension to the analysis. An assessment of the functionality of the websites of municipal administrative authorities was carried out in accordance with sixteen criteria. However, the description of criteria used was not provided in the paper. A slightly more sophisticated approach has been used by Golam and Sutana (2013) to analyse quality and performance of travel websites that provide customers with diverse services including travel information and products. Their study discusses the major factors for travel agency websites' quality from the viewpoint of users' perception (by applying users' survey), and explores the use of Fuzzy Technique for Order Preference by Similarity to Ideal Solution for the evaluation. It also deals with a number of attributes and criteria of website quality, however these measures are taken from audience pool, thus limiting research to an assessment of just five websites. The mentioned works use different website popularity or quality indicators to draw conclusions about e-services or e-businesses in different contexts. The indicators are very useful for the comparison of similar e-services and for the evaluation of an e-service changes over time. Such data are objective and can be gathered automatically for large number of websites. Therefore a comparison of the same set of websites at various time intervals, using an indicators' matrix may allow to draw valuable conclusions related to both the performance of the companies involved in the grant scheme performance and to the grant scheme itself. The methodology employed in this paper involved two rounds of investigation. Primarily, in August 2015, an online search was conducted, using website addresses of the beneficiaries and other basic data provided in the publicly available list of grants, published by Polish Agency for Enterprise Development. Out of the 2,730 above mentioned projects, a list of 1,611 web addresses was prepared and a basic characteristics of the sample was derived, along with its division into 13 chronological calls, as mentioned in the first section of this paper. The next wave of data collection took place after almost 3 years i.e. in February 2018 and involved all

previously analysed websites, however not all of them were accessible. Scripts in the Python language were used to identify website information, including automatic queries sent to selected valuation services, which are unprotected for automatic queries (e.g. by Captcha code).

### 3. FINDINGS

Table 1 shows the volume of websites identified by this search versus the number of signed contracts for each call. Next, Alexa traffic rank ([www.alexa.com](http://www.alexa.com)) is used to identify active websites. Alexa is based on a combined measure of unique visitors and page views. The value of Alexa rank isn't based only on traffic to the given site, but takes into account the traffic to all sites and ranks sites relative to each other, hence changes in traffic to other items affect the position of a site with stable traffic. However, non-ranked websites can simply be regarded as out of users' interest, generating negligible traffic. All in all, for the 2,730 grants, 1,611 related websites were identified, representing 59% of projects. One of the reasons for relatively low rate of recognition is the possibility that some subsidized enterprises changed their names, so it was impossible to find them on the Internet. Some grants might have been allocated for the creation of e-services' components, thus the results in the form of final services were invisible. Nevertheless, what seems very probable is that many of the e-services that did not appear online simply failed in the meantime. Still, the number of locatable services is big enough to enable the analysis of the appearance in Alexa rank both in 2015 and 2018. During this period on average 17% of services disappeared from the ranking, with low differences between earlier and later calls in this respect.

*Table 1: Websites subsidised by 8.1 Measure (Source: Own research)*

Call number	Number of contract signed	Number of websites found (2015)	Websites ranked by Alexa in 2015	Websites ranked by Alexa in 2018
2008	221	115	67	43
2009 first	352	179	95	67
2009 second	441	236	123	92
2009 third	397	239	104	76
2010	166	117	33	30
2011 first	136	90	36	30
2011 second	97	59	20	18
2012 first	114	77	23	15
2012 second	142	92	31	18
2012 third	217	137	52	32
2013 first	111	65	26	19
2013 second	158	105	38	25
2013 third	178	100	32	24

However, the presence in Alexa ranking does not fully account for the changes in these services' popularity and utility. Another measure derived from [service.siteprice.org](http://service.siteprice.org) has been employed, i.e. Facebook Like Count. Facebook likes related to the analysed website, mean that the site is promoted on social media, or there is a social media community liking the site. All websites from the list that have this measure greater than zero were counted and an evolution of that measure over time was traced. Out of 630 websites that were liked in 2015 only 56 have maintained a minimum level of popularity in 2018, amounting to a 91% drop in just three years. There is no clear pattern of decreasing popularity – some older services are performing better than the relatively new ones, however in all cases only a few seem to have the potential to attract long lasting public interest.

*Table 2: Popularity of subsidized websites on Facebook (Source: Own research)*

Call number	No of websites liked on Facebook 2015	No of websites liked on Facebook 2018	Decrease in percentage
2008	53	6	-89%
2009 first	83	4	-95%
2009 second	105	11	-90%
2009 third	97	6	-94%
2010 first	47	5	-89%
2011 first	42	5	-88%
2011 second	26	4	-85%
2012 first	26	0	-100%
2012 second	31	3	-90%
2012 third	44	3	-93%
2013 first	23	1	-96%
2013 second	30	4	-87%
2013 third	23	4	-83%

The siteprice.org site is an intermediary for selling/buying of websites combined with a free website value calculator. It estimates the value of a website as its possible market price. The calculations are based on a proprietary algorithm using own database and data from Internet resources. The included indicators are: Google PageRank, Alexa rank and a domain's age as well as data gathered from search engines (i.e. Google, Yahoo, and Bing) and from social media websites (Facebook, Twitter, Google+). Table 3 presents the number of sites from each call that was valued to be worth more than USD 1000. Regardless of the initial low valuation of sites in comparison with the average value of the grant issued, in range of USD 150 thousands equivalent, what should be noted, is that the number of sites worth more than USD 1000 more than halved over the researched period from 464 in mid-2015 to just 210 in early 2018.

*Table 3: Number of websites valued by SitePrice to be worth more than USD 1000  
(Source: Own research)*

Call number	2015	2018
2008	62	30
2009 first	76	38
2009 second	101	41
2009 third	83	42
2010 first	32	14
2011 first	22	8
2011 second	14	5
2012 first	11	4
2012 second	8	3
2012 third	21	10
2013 first	10	3
2013 second	12	5
2013 third	12	7

#### 4. CONCLUSION

Websites' characteristics analysis can be a good proxy for performance estimation of companies set up to provide specific e-services. Although Welling and White (2006) noted that despite the

availability of large amount of site usage data, there is no clear way to determine how performance of a company's website affects shareholders' value. Another finding is that actually the performance and utility of sponsored websites deteriorates quickly and the 8.1 Measure will probably not have long-lasting effects. The possible explanations for such a phenomenon can include multiple factors from the data collection errors to the unaccountability for the real effects of the niche e-services created. The presented research, however, has only aimed at checking to what extent the analysed websites are developing, and the main finding is that actually they are disappearing rather than blossoming. This evidence supports the view that the traditional notion of industrial public support is limited in application to e-services and in fact, the programme was discontinued within the following EU budget for 2014-2020. However, our analysis does not take into account the indirect effects of such initiatives as the creation of new development teams that are ready to work in subsequent projects related to e-services, the acquired valuable experience of the new companies, which makes them more eager to engage in new e-projects and last but not least, the direct job creation. Further research may attempt to identify both the factors of success in case of the surviving websites and alternative, more effective methods of support which can be applied to develop e-business in the future.

#### **LITERATURE:**

1. Arduini, D. and Zanfei, A., (2014), "An Overview of Scholarly Research on Public e-Services? A meta-analysis of the literature", *Telecommunications Policy*, Vol. 38, no. 5, June-July, pp. 476-495, Elsevier.
2. Chmielarz, W. and Parys, T., (2018), "Changes in the Use of Websites in E-Commerce in 2017-2018", *Economic and Social Development (Book of Proceedings), 33rd International Scientific Conference on Economic and Social Development – "Managerial Issues in Modern Business"*, Warsaw Poland, 26-27 September, pp. 21-29.
3. Czarnowski, I. and Szyda, M., (2018), "Technological Quality Assessment in Online Commercial Services", *Economic and Social Development (Book of Proceedings), 33rd International Scientific Conference on Economic and Social Development – "Managerial Issues in Modern Business"*, Warsaw Poland, 26-27 September, pp. 597-606.
4. Gneiser, M., Heidemann, J., Klier, M., Landherr, A. and Probst, F., (2012), "Valuation of Online Social Networks Taking Into Account Users' Interconnectedness", *Information Systems and e-Business Management*, Vol. 10, no. 1, March, pp. 61-84, Springer.
5. Jakimowicz, A., Rzeczkowski, D., (2018), „Application of the Four Colour Theorem to Identify Spatial Regional Poles and Turnpikes of Economic Growth”, *Acta Physica Polonica, A.*, Vol. 133, Issue 6, pp. 1362-1370, Polish Physical Society.
6. Kabir, G., Sumi, R.S., (2013) "Evaluation of travel website service quality using fuzzy topsis", *Suranaree Journal of Science & Technology*, Vol. 20 Issue 1, pp. 21-33, Suranaree University of Technology.
7. Hu, L. and Zhu, M., (2013), "Competitive Intelligence Acquisition From Websites", *Proceedings of the 10th International Conference on Fuzzy Systems and Knowledge Discovery*, Shenyang China, 23-25 July, pp. 858-862.
8. Moroz, M., (2014), "Ocena funkcjonowania działania 8.1 'Wspieranie działalności gospodarczej w dziedzinie gospodarki elektronicznej' Programu Operacyjnego Innowacyjna Gospodarka", *Studies & Proceedings Polish Association for Knowledge Management*, no. 71, pp. 117-128.
9. Santos, J.J.T, (2013), "E-Commerce and the Rise of the Online Business: The Identification and Valuation of Cyber Assets", *Ateneo Law Journal*, Vol. 57, no. 4, March, pp. 1219-1233, Law Publications Center.
10. Welling, R. and White, L., (2006), "Measuring the Value of Corporate Web Sites", *Journal of Internet Commerce*, Vol. 5, no. 3, pp. 127-145, Taylor&Francis.



## WOMEN IN THE SLOVAK IT SECTOR: FROM EDUCATION TO LABOR MARKET

**Peter Psenak**

*Faculty of Management Comenius University in Bratislava, Slovakia  
Peter.Psenak@fm.uniba.sk*

**Urban Kovac**

*Faculty of Management Comenius University in Bratislava, Slovakia  
Urban.Kovac@fm.uniba.sk*

**Jan Kacer**

*Faculty of Management Comenius University in Bratislava, Slovakia  
Jan.Kacer@fm.uniba.sk*

**Miroslava Skypalova**

*Faculty of Management Comenius University in Bratislava, Slovakia  
Miroslava.Skypalova@fm.uniba.sk*

### ABSTRACT

*The difference between men's and women's average earnings and other gender issues in the Slovak Republic is one of the largest in the EU and has been very persistent over time. This paper explores the origins of recruitment gender issues using the sample of young and highly skilled workers looking for IT position at the beginning of their career in Slovakia. The data for this study comes from different sources to combine information about graduate's university, employment and employer's characteristics. The study describes the current state of the gender issues in Slovakia IT sector based on data sets obtained from National Social Security insurance institution and the biggest job and recruitment portal („Profesia“) in Slovakia. The analysis combines data from administrative records on the whole cohort of graduates including information on graduate's university, gross monthly earnings and graduate's characteristics. Data further includes information from CVs such as various skills characteristics and number of CVs seen by potential employers per graduate. We further discuss whether employers prefer men to women, even when women have the same skills as men in Slovakia during recruitment process for IT positions. Results from logistic regression models have shown that odds male's CV seen by employer's is not significantly different from female seen CV's.*

**Keywords:** *discrimination, IT, Slovak labor market, wage gap, women, information technology, gender equality, information and communication technologies*

### 1. INTRODUCTION

Between main determinants that determine the wages belongs sex as shown by Mussida et al., 2014, who examined gender pay gaps in Italy. Many studies looked at the widespread phenomenon of gender inequality in income, with an initial study being considered by Becker et al., 1957 and Mincer, 1958, who argue that gender inequality in income is mainly due to two factors:

1. the difference in male and female labor productivity,
2. market discrimination against women from the perspective of the employer, employee and customer.

Authors such as Bergmann, 1974, Bielby et al., 1986 and Meng, 2004 point to the fact that segregation of women and men in employment, industry, enterprises and jobs significantly

contributes to wage inequality. Blau and Kahn in their 1992, 1996 and 1997 research have shown that since 1970 gender pay gap has narrowed in most developed countries. The largest reduction of gender wage gap was recorded in the last 30 years, as shown by Even et al., 1993 and Leonard, 1996, Blundell et al., 2007, Flabbi, 1997, Jolliffe et al.. The most significant change in wage inequality was in low-income groups (Fitzenberger et al., 2001). The current EU policy is strongly intended to close the pay gap between women and men, but the differences still persist. The EU identifies two main sources, which mainly contribute to the gender pay gap. The first is the segregation of men and women in occupations, in enterprises to the level of jobs. The second source for wage differentials is the preference and dominance of men in many jobs and places. From these two sources, factors that significantly affect the wage gap between the two sexes are known to us. One factor is, for example, the high proportion of women in certain types of occupations where their share is much higher than men and thus contributes to the widening of the wage gap, as it is likely that another trainee for this type of profession will again be female and wages in these occupations are mostly low. The unequal distribution of the number of women and men in different sectors and professions has a direct impact on wage differences. The aim of this study is to explore the gender issues in Slovakia IT sector. Study has following sections. In the first section is given literature review about gender pay gap and other gender issues. In third section is described used data sets, models and discussion. In the last section, the conclusion is drawn.

## **2. GENDER WAGE GAP**

Most economic studies primarily focus on individual characteristics such as education, work experience in years on total income gaps, including gender inequalities. Sociological studies have shown that the characteristics of individual occupations and the unequal distribution of men and women in occupations have a significant impact on segregation and its impact on wage inequalities (Petersen et al., 1995; Tomaskovic-Devey et al., 2002, Weeden, 2002).

### **2.1. Reasons for gender wage gaps**

Economic studies more emphasize individual characteristics such as education, age and years of practice, and so on. Sociological studies are more focused on the effects of profession on gender differences (Mandel, 2016).

#### *2.1.1. Social closure*

Mandel (2016) and Weeden (2002) describe how certain professional groups create barriers and barriers in specific occupations that limit the entry of new workers, thereby hindering their economic and social benefits. They further point out that introducing the need for certified education, licenses and certificates leads to a positive effect on increasing income gaps. Tam (1997) and Estevez-Abe (2005) describe that the professions where the acquisition of certified skills is required are more tailored to men who mostly follow the path of lifelong career growth, thus dominating men in this type of profession. On the other hand, the effect of social closures can protect women's wages in relation to men in preferential occupations. Goldin (2002); Cotter et al. (2004) and Mandel (2016) found that if the profession is a higher education (tertiary), then it is in favor of an employee from less advantaged groups, and this also has an impact on reducing the gap between men and women. The recruitment process in these cases works to demonstrate that the candidate has the required skills and the employer has no reason to question the qualifications and productivity of the future employee on the basis of gender. We can apply such claims to professions that require long-term training that are more gender-equivalent, as employers have no reason to question the productivity and skills of these disadvantaged groups. The higher the level of education required by the specific profession, the smaller the differences (Mandel 2016).

### *2.1.2. Devaluation*

The devaluation of the position of occupation holders based on race and gender contributes to a discriminatory effect within occupations that affects gender pay disparities (Tomaskovic-Devey, 2002). Ridgeway (2011) argues that general awareness of lower skills and competencies of women contributes significantly to the degradation of the profession associated with women's skills and activities. England (2005) points to the fact that the devaluation effect also contributes to wage discrimination in occupations with a predominant number of women, which reduces their social status and wages.

### *2.1.3. Public sector employment*

The public sector is characterized by bureaucratic and regulated working practices and practices as compared to the private sector. The bureaucratic and regulated public sector work environment limits employers to pay a different pay for men and women in the same job positions, ie lower wage discrimination in the public sector and tendency to favor disadvantaged groups in general, such as women (Mandel and Semyonov, 2014; Mandel, 2016). The benefit of the public sector for women is mostly explored on an individual approach. Working conditions in the public sector have an impact on employment in the private sector, as both sectors are on the labor market for the same employees (Mandel, 2016). If salaries and working conditions are better in the public sector, employees prefer to work there, which puts pressure on wages in the private sector.

### *2.1.4. Glass ceiling*

Glass ceiling: is the effect that creates invisible and even breakable barriers that hold disadvantaged groups and women from occupations regardless of their qualifications and outcomes. This effect is mainly observed in cases of promotion or recruitment of employees to higher positions, where the likelihood of occupation by a woman falls with the increasing importance and importance of the position compared to males (Cotter et al., 2001). It is expected that the gender pay gap will be higher in the professions closer to the top of the working pyramid (Mandel, 2016), and at the same time it is assumed that with the increasing number of women in well paid positions, this effect will contribute to wage differentials in within these positions.

### *2.1.5. Working conditions*

They are associated with the so-called " the effect of "compensating differentials", which is defined as an additional income to the basic salary and serves as motivation for an employee who is required to accept a profession in which he is exposed to bad or unusual working conditions such as extreme heat or winter, noise, risk and so on. Studies are divided into results as to whether working conditions contribute to the pay gap between women and men (Kilbourne et al., 1994).

### *2.1.6. Labour market supply and demand*

The predominance of the labor market tends to reduce the average salary in occupations, and surplus demand pushes average earnings up. In general, the lower political power of women, and the preference of men by employers, blocks women in general in their careers and at the same time they are less effective in negotiating good working conditions and wages

## **2.2. Women in IT**

Manju Ahuja proposed in 2002 a model of barriers faced by women in IT in three different career stages (choice, persistence and progress). Due to the fact that this model was obsolete, it was reworked in 2013, where it was found that the perceptions of structural and social factors affecting the life of women in the IT sector changed over the years (Armstrong -

Riemenschneider, 2014). Akinol (2015), in his research, proved that gender does not affect the ability to write code effectively. According to research that found the opinion of teachers of information science on women's and men's learning, girls found a more structured approach to learning but less self-confidence and doubt about their skills in computer science (Gallivan, 2003).

### **3. METHODOLOGY & DATA**

The aim of the research is to find out whether employers in the territory of the Slovak Republic in finding jobseekers requiring knowledge, skills and skills related to information technologies prefer men to women, even when women have the same skills as men. To confirm or refute this claim, we want to use a variety of statistical analyzes of a set of data that contains appropriate information for this research. We assume that women, even if they control the IT skills that the employer is looking for, are still disadvantaged against men, with the same and maybe even lower IT competencies. Using statistical models, we will try to determine whether there is a predicted dependency and, if it occurs, to determine if new data can be estimated on its basis. The hypothesis that needs to be confirmed or refuted is as follows:

- H1 Employers prefer men with IT skills to women with the same skills.

#### **3.1. Data**

We used the portal, »Profesia.sk« (biggest jobfair web site in Slovak republic), and CVTI data processed within the above-mentioned project of the Center for Scientific and Technical Information of the Slovak Republic. These were data for students / graduates from 2008 to 2014, where Professionals, for example, provided data such as individual graduate skills, CV views, graduated college and union, and others. CVTI provided data such as a list of universities and universities, a list of study departments, and others. A more precise description of the variables used is given later. All the data used was anonymized.

The survey used data from over 5,200 CVs that were located and found on the Profession portal, and met the ICT skills criteria for the years under review.

From the data available, we have selected the following variables in our models:

1. Number of Curriculum Openings: contains the number of times the CV has been opened on the web site.
2. Gender: contains the gender of the person whose CV was open.
3. Age: contains the age of the person whose CV was open.
4. University: a university which the person has completed or is still studying.
5. Skills of the individual: includes the abilities of the individual listed in the biography.

#### **3.2. Methodology**

We are focusing our research on IT graduates therefore we used only CVs from IT related fields of study. In order to simplify the analysis, we made several adjustments in the available data, but these do not have a negative impact on the results obtained. In the original data, 17 different universities were found in CVs, attending or terminating candidates. We have reduced their number so that universities that were listed in the database of less than 350 students were linked under the name of Others. The Slovak Technical University was the only one in the database to have more than 1 000 graduates. In terms of statistics, universities have been coded as factor variables, given that they are nominal data. In Table 1 you can see numbers of CVs per university. Extreme values were not deducted from the models during analyses. In table 2 we can see some basic descriptive statistics of our dataset. The smallest number of CVs opened by employers was 1 and the highest was 64. It is clear from descriptive statistics that data also contain extreme values because median (2nd quartile) is 4 whereas first and third quartiles are only 2 and 9. This means that 75 % of data is under 9.

*Table 1: Frequency table CVs per University*

<i>University</i>	<i>CV count</i>
University of Economics in Bratislava (EU)	439
University of Žilina (ŽU)	711
Slovak University of Technology in Bratislava (STU)	1864
Technical University of Košice (TU)	964
Comenius University in Bratislava (UK)	394
Other	895

*Table 2: Frequency table CVs per University*

	<i>Minimum</i>	<i>1.quartil</i>	<i>Median</i>	<i>Average</i>	<i>3.quartil</i>	<i>Maximum</i>
<b>Count of opening of CV</b>	1,000	2,000	4,000	6,555	9,000	64,000
<b>Age</b>	18,00	22,00	23,00	23,55	24,00	53,00

We didn't remove extreme values in our research. On the histogram (Figure 1), it is evident that most of the values of the number of CVs are cumulative at number 1. Due to the large number of values in the number of openings 7-13 we can state that in the given database these values affect the deviation between the mean value and the median, which differs by up to 2.5 against the median. The Data Module is just one opening that occurred in 864 cases.

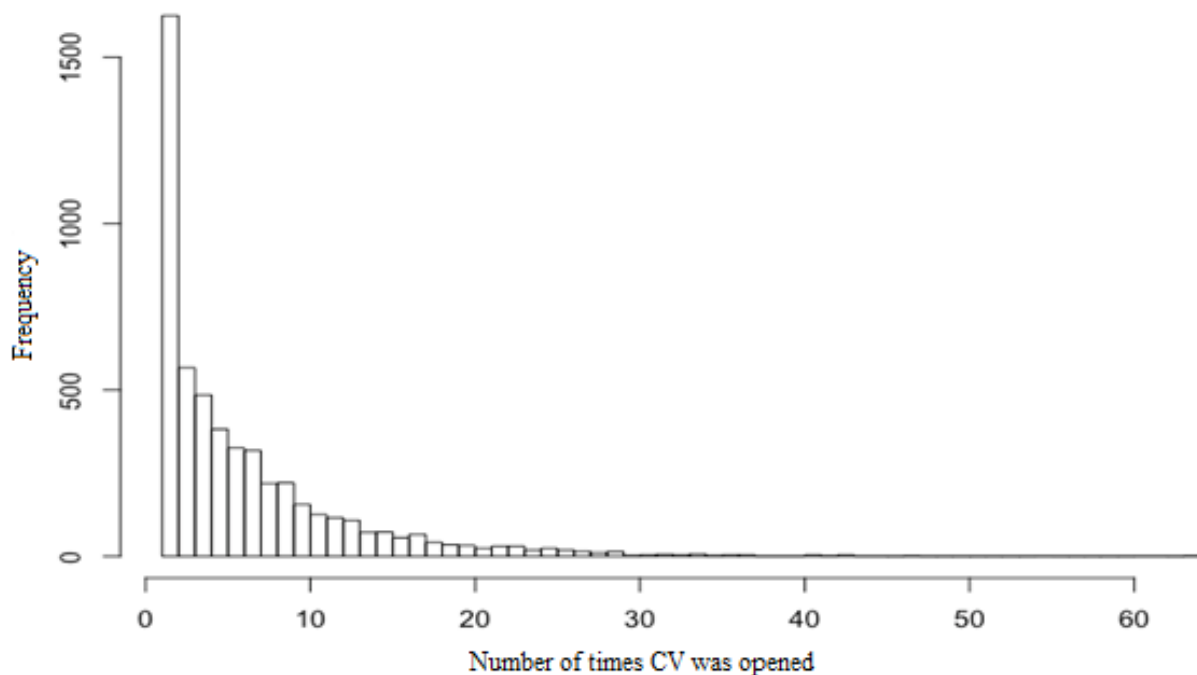

*Figure 1: Histogram of CV opening*

The third nominee in the analysis is the gender of the person who placed the resume on a web page. We use it as a categorical variable in analyzes, from which we can see that women are adequately represented in the statistical selection of CVs, as they account for only 12.7% of 87.3% of men. The last discrete variable is age. This variable was not entered directly in the data obtained but was created based on the date of birth and the date when the resume from the page was downloaded (or last updated). The minimum age is 18 and a maximum of 53 years. Median and average is 23 years.

The average age was also added in cases where the birth date was missing. Such cases were around 300. The largest representation in the data base were those aged 20-26 who made up to 4,804 data, of which 24 were year-olds 1,194 and 23 year-olds 1,123 (in this group are also those who were assigned mean age). The age modus is also 24. We use this data in multivariate regression analysis:

$$Y_i = b_0 * b_1 * gender + b_2 * age + b_3 * university$$

We have chosen University of Economics in Bratislava as reference value for university and woman as reference value for gender. Results are below in in Table 3 and residuals in Table 4.

Table 3: Multivariate regression analysis - coefficients

<i>Coefficient</i>	<i>Estimate</i>	<i>Std. Error</i>	<i>t-value</i>	<i>p-value</i>
<b>Intercept</b>	2,47711	0,99173	2,498	0,012535
<b>Men</b>	1,94904	0,30148	6,465	1,13e <sup>-10</sup>
<b>Age</b>	0,12453	0,03761	3,311	0,000938
<b>ZU</b>	-1,24770	0,43756	-2,852	0,004372
<b>Other universities</b>	-1,69765	0,41414	-4,099	4,22e <sup>-5</sup>
<b>STU</b>	0,05590	0,38200	0,146	0,883686
<b>TU</b>	-1,24919	0,41034	-3,044	0,002347
<b>UK</b>	1,10246	0,49634	2,221	0,026392

Table 4: Multivariate regression analysis - residuals

<i>Residual</i>	<i>Minimum</i>	<i>1. quartile</i>	<i>Median</i>	<i>3. quartile</i>	<i>Maximum</i>
	-9,180	-4,222	-1,973	2,083	58,208

In this model, the dependent variable is the number of CVs opened, and the gender, age and university are independent. At the end of the analysis we can state that the model is not able to predict future values of appearance, but still operates with statistically important variables. Based on regression, we can say that gender, age, and university attendance have an impact on the number of CV views, albeit only low. Based on past results, we can claim that if the gender is male, it has two openings (views) more. From the point of view of age, this fact is noticeably weaker, but the number of resumes of biographies increases by 0.12 per person each year. This value is even lower than for the genus. In universities, the results are more diverse. Interesting and surprising for us is the weak impact of the University of Technology on the number of views. This could have been the result, for example, of the fact that a large number of people who have seen CVs as their TUs usually had only one look. We have to keep in mind that in the modeling of multiple linear regression we retained the original data, which were represented very disproportionately from the point of view of the genus. We will try to remedy this phenomenon by bringing in the number of men and women and improving our model. For this reason, we will proceed to further analysis that could contribute to improving the model's results, namely logistic regression. Results for logistic regression are in Table 5.

Table following on the next page

Table 5: Logistic regression - results

<i>Coefficients</i>	<i>Estimate</i>	<i>Std. Error</i>	<i>z value</i>	<i>p value</i>
<i>Intercept</i>	-1,236149	0,339417	-3,642	0,000271
<i>Number of views</i>	0,082725	0,008032	10,299	$< 2e^{-16}$
<i>Age</i>	-0,010899	0,013405	-0,813	0,416210
<i>ŽU</i>	1,402389	0,156030	8,988	$< 2e^{-16}$
<i>Other universities</i>	0,588333	0,138377	4,252	$2,12e^{-5}$
<i>STU</i>	1,677556	0,132785	12,634	$< 2e^{-16}$
<i>TU</i>	1,182642	0,142550	8,296	$< 2e^{-16}$
<i>UK</i>	0,704899	0,173307	4,067	$4,76e^{-5}$

Table 6: Logistic regression - residuals

<i>Residual</i>	<i>Minimum</i>	<i>1.quartile</i>	<i>Median</i>	<i>3.quartil</i>	<i>Maximum</i>
<i>Values</i>	-2,2209	-1,0760	-0,6538	1,0593	1,8938

Table 7: Logistic regression - parameters

<i>Dispersion parameter for binomial family</i>	1
<i>AIC (An Information Criterion)</i>	4 039,3
<i>Number of Fisher Scoring iterations</i>	4

In this model, the dependent variable is the gender, and the independents are the university, the age, and the number of CVs opened. Similarly to multivariate regression, we first analyze the residue table. Even in this case, these are distances that have real data values from the values created by the model. This part of the output shows the distribution of residual deviations for the individual values used in the model. The ideal case is if the values are symmetrically divided by 0. In our case, the minimum value is -2.2209 and the maximum is 1.8938. At first glance, it can be concluded that due to the higher symmetry of the residue, it is better than the multiple linear regression. When analyzing the regression parameters, we first analyze the number of CV resumes. The estimated number of openings is 0.08. If the total opening of CVs increases by one opening, the likelihood of a man being raised will be 8%. The standard variable error is 0.008, the z-test value is 10.299, and the p value is below 0.05, so this variable is significant for the model. The age has a significantly lower estimate and negative (-0.01). Its p value is just below 0.05, i.e. is significant in the model, but its impact on the model is smaller than for the other parameters. In terms of universities, all parameters are significant in comparison to multiple linear regression, with the University of Slovak Technical University in Bratislava, the Technical University in Košice and the University of Žilina being among the most influential factor variables on the model. In their case, the probability of up to 100% is that a student of these universities is a man. In the case of Comenius University this probability is 70% and in the common category Other it is 58%.

#### 4. CONSLUSION

Based on the results obtained using analyzes performed on created models, we have survived to confirm or refute the established hypothesis. In multivariate linear regression the results showed that the variable has an impact on the number of CVs opened.

In the case of logistic regression, the number of CVs opened has an impact on gender. It follows that both the variable and the number of CVs are a significant factor for the models. Based on the above, we state that the hypothesis H1 has been confirmed. This means that men are preferred when choosing an employee in the IT sector. As a further finding from the analysis of the results of the presented work, we can also say that variable age is significant for multiple linear and logistic regression models, but after reducing the force of extreme values in robust regression it was found that it does not affect the number of CVs opening. A similar finding is that the variable university is significant in each of these models. All models were tested for relevance by a variety of methods, and we have proven that their evaluated statistics are significant. Unfortunately, the ability to estimate new model values is very low in all cases. For this reason, it is not recommended to use them to predict new values. During the examination of skills, we have found some very interesting facts. In computer science, women primarily focus on other specializations as men.

### LITERATURE:

1. AHUJA, M. K. (2002) *Women in the information technology profession: a literature review, synthesis and research agenda*, *European Journal of Information Systems*, 11:1, 20-34, DOI: 10.1057/palgrave.ejis.3000417
2. AKINOLA, O. S. *Computer programming skill and gender difference: An empirical study*. In *American Journal of Scientific and Industrial research* [online]. 2015, 1-6 s. [cit. 2017-11-11]. Available from: <<https://scihub.org/media/ajsir/pdf/2016/02/AJSIR-7-1-1-9.pdf>>. ISSN 2153-649X.
3. ARMSTRONG, J. D. - RIEMENSCHNEIDER, K. C. *The Barriers Facing Women in the Information Technology Profession: An Exploratory Investigation of Ahuja's Model* [online]. SIGMIS CPR, 2014 s. 85-96 Available from: <<http://dl.acm.org/citation.cfm?id=2381099>>. ISBN 978-1-4503-2625-4.
4. BECKER, G. S. et al., 1957. *economics of discrimination*.
5. BERGMANN, B., 1974. *Occupational Segregation, Wages and Profits When Employers Discriminate by Race or Sex*. *Eastern Economic Journal*. Vol. 1, č. 2, s. 103–110. Available from: <<https://EconPapers.repec.org/RePEc:eej:eeconj:v:1:y:1974:i:2:p:103-110>>.
6. BIELBY, W. T; BARON, J. N, 1986. *Sex segregation within occupations*. *The American Economic Review*. Vol. 76, č. 2, s. 43–47.
7. BLAU, F. D; KAHN, L. M, 1992. *The gender earnings gap: learning from international comparisons*. *The American Economic Review*. Vol. 82, č. 2, s. 533–538.
8. BLAU, F. D.; KAHN, L. M, 1996. *Wage structure and gender earnings differentials: an international comparison*. *Economica*, s. S29–S62.
9. BLAU, F. D; KAHN, L. M, 1997. *Swimming upstream: Trends in the gender wage differential in the 1980s*. *Journal of Labor Economics*. Vol. 15, č. 1, Part 1, s. 1–42.
10. BLUNDELL, R.; GOSLING, A.; ICHIMURA, Hidehiko; MEGHIR, Costas, 2007. *Changes in the distribution of male and female wages accounting for employment composition using bounds*. *Econometrica*. Vol. 75, č. 2, s. 323–363.
11. COTTER, D. A. at all. *Gender Inequality at Work*. In *Russell Sage Foundation* [online]. 2004. [cit. 2017-9-14]. Available from: <<https://www.prb.org/genderinequalityatwork/>>.
12. COTTER, D. A. at all. *The Glass Ceiling Effect*. In *Social Forces* [online]. 2001. Vol. 80, no.2, 655-681 p. [cit. 2017-11-15]. Available from: <<https://doi.org/10.1353/sof.2001.0091>>.
13. ENGLAND, P. *Emerging theories of care work*. In *Annual Review of Sociology*. [online]. 2005. Vol. 31, 381-399 p. [cit. 2017-11-15]. Available from: <<https://doi.org/10.1146/annurev.soc.31.041304.122317>>.
14. ESTEVEZ-ABE, M. *Gender bias in skills and social policies: the varieties of capitalism perspective on sex segregation*. In *Social Politics: International Studies in Gender, State & Society*. 2005. [online]. Vol. 12, Issue 2, 180–215 p. [cit. 2018-03-12]. Available from: <<https://doi.org/10.1093/sp/jxi011>>.



15. EVEN, W.; MACPHERSON, D., 1993. *The Decline of Private-Sector Unionism and the Gender Wage Gap*. In *Journal of Human Resources*. Vol. 28, č. 2, s. 279–296. Available from: <<https://EconPapers.repec.org/RePEc:uwp:jhriss:v:28:y:1993:i:2:p:279-296>>.
16. FITZENBERGER, B.; WUNDERLICH, G., 2001. *The changing gender gap across the wage distribution in the UK*. ZEW discussion papers. Vol. 1.
17. FLABBI, L., 1997. *Gender discrimination and return to education: estimations on individual data*. *Rivista di Politica Economica*. Vol. 87, s. 173–213.
18. GALLIVAN, M. *Examining Gender Differences in IT Professionals Perceptions of Job Stress in Response to Technological Change* [online]. 2003, Philadelphia, Pennsylvania, SIGMIS CPR, 10-23 s. [cit. 2017-10-15]. Available from: <<http://dl.acm.org/citation.cfm?id=761852>>. ISBN 1-58113-666-8.
19. GOLDIN, C. *A Pollution Theory of Discrimination: Male and Female Differences in Occupations and Earnings*. In *National Bureau of Economic Research* [online]. 2002. [cit. 2018-02-14]. Available from: <<http://www.nber.org/papers/w8985>>.
20. JOLLIFFE, D.; CAMPOS, N. F., 2005. *Does market liberalisation reduce gender discrimination? Econometric evidence from Hungary, 1986–1998*. *Labour Economics*. Vol. 12, č. 1, s. 1–22.
21. KILBOURNE STANEK, B. at all. *Returns to skill, compensating differentials, and gender bias: effects of occupational characteristics on the wages of white women and men*. In *The American Journal of Sociology*. [online]. 1994. Vol. 100, no. 3, 689-719 p. [cit. 2017-11-16]. Available from: <<http://www.jstor.org/stable/2782402>>.
22. LEONARD, J. S., 1996. *Wage Disparities and Affirmative Action in the 1980's*. *The American Economic Review*. Vol. 86, č. 2, s. 285–289.
23. MANDEL, H., 2016. *The role of occupational attributes in gender earnings inequality, 1970–2010*. *Social Science Research*. Vol. 55, s. 122–138. Available from DOI: <10.1016/j.ssresearch.2015.09.007>, ISSN 0049-089X.
24. MANDEL, H. - SEMYONOV, M. *Gender pay Gap and employment sector: sources of earnings disparities in the United States, 1970-2010*. In *Demography* 2014. Vol. 51, no. 5, 1597-1618 p. ISSN0070-3370.
25. MENG, X. 2004. *Gender earnings gap: the role of firm specific effects*. *Labour Economics*. Vol. 11, č. 5, s. 555–573. Available from: <<https://EconPapers.repec.org/RePEc:eee:labeco:v:11:y:2004:i:5:p:555-573>>.
26. MINCER, J., 1958. *Investment in human capital and personal income distribution*. *Journal of political economy*. Vol. 66, č. 4, s. 281–302.
27. MUSSIDA, Ch.; PICCHIO, M., 2014. *The gender wage gap by education in Italy*. *The Journal of Economic Inequality*. Vol. 12, č. 1, s. 117–147. ISSN 1573-8701. Available from DOI: <10.1007/s10888-013-9242-y>.
28. PETERSEN, T.; MORGAN, L. A., 1995. *Separate and Unequal: Occupation-Establishment Sex Segregation and the Gender Wage Gap*. *American Journal of Sociology*. Vol. 101, č. 2, s. 329–365. Available from DOI: <10.1086/230727>.
29. RIDGEWAY, C. L. *Framed by Gender: How Gender Inequality Persists in the Modern World*. 2011. Oxford University Press, New York. ISBN-13:9780199755776.
30. TAM, T. *Sex segregation and occupational gender inequality in the United States: devaluation or specialized training?* In *The American Journal of Sociology*. [online]. 1997. Vol. 102, no. 6, 1652-1692 p. [cit. 2018-02-12]. Available from: <<http://www.jstor.org/stable/10.1086/23112>>.
31. TOMASKOVIC-DEVEY, D.; SKAGGS, S., 2002. *Sex segregation, labor process organization, and gender earnings inequality*. *American Journal of Sociology*. Vol. 108, č. 1, s. 102–128.
32. WEEDEN, K. A., 2002. *Why Do Some Occupations Pay More than Others? Social Closure and Earnings Inequality in the United States*. *American Journal of Sociology*. Vol. 108, č. 1, s. 55–101. Available from DOI: <10.1086/344121>.

## MODELING ECONOMIC IMPACT OF NUCLEAR POWER PLANT FOR POLAND

**Mariusz Plich**

*University of Lodz, Poland  
mariusz.plich@uni.lodz.pl*

**Lukasz Konopielko**

*Lazarski University, Poland  
lukasz.konopielko@lazarski.pl*

### **ABSTRACT**

*This study analyzes the factors affecting the development of energy sector in Poland, particularly envisaged construction of first nuclear power plant. The input output model Empower.PL is employed to account for changes in economic aggregates, as well as the reduction in greenhouse gas emissions. Set of equations is described that constitute the full version of the model, reflecting the four types of multiplier mechanisms present in the economy. Preliminary results of model use for estimating the effects of the construction of nuclear power plant in Poland are presented, that demonstrates model capacities. Financing nuclear power plant construction from public funds, without changing the amount and structure of existing expenditures, means the need to limit and reallocate resources previously allocated for consumption. Further development of the model should lead to more accurate than preliminary results presented in this paper.*

**Keywords:** *nuclear energy, greenhouse gas, emission, input output model, Poland*

### **1. INTRODUCTION**

The purpose of this paper is to discuss the assumptions and preliminary results of model designed to assess the impact of changes within the energy sector in Poland in the context of Nuclear Power Plant (NPP) construction. The reduction of greenhouse gas emissions can be mainly achieved by eliminating or limiting the combustion of fossil fuels, as well as ex post, through the use of capture technology of the CO<sub>2</sub> emitted from coal-fired power plants. In view of the expected increase in the production and consumption of electricity and the need to reduce the combustion of fuels containing coal, there is a need for the development of alternative sources of energy. This can be achieved by increasing the share of renewable energy, but also by construction of new NPPs and relying on them to a greater extent to supply energy to the national power systems. At present, in the European Union more than 150 reactors produce even more than 30% of the required electricity. Resistance to the construction of new NPPs in many countries, including Poland, is however very high, which is a derivative of historical conditions and political stereotypes, but also changes in consumer preferences. The Polish National Energy System is traditionally based on natural resources of national origin in the form of coal and lignite (significantly more than 80% share in electricity production and over 70% in installed capacity), however its efficiency is constantly improving (Stachura, 2018). This paper is an introduction to analyses referring to the anticipated changes in the energy mix in Poland as well as to the model aimed at estimating the impact of the aforementioned changes on the emissivity of the economy, particularly by the construction of one or more NPPs. It describes the basic assumptions of model, the process of estimation of its equations and indicates how analysis of the model scenario proceeds that assumes increase of power system production capacities by nuclear technologies which push out technologies based on coal traditionally used for electric power generation in Poland.

## 2. DESCRIPTION OF THE MODEL AND DATA

International Atomic Energy Agency (IAEA) develops and maintains several models for the energy planning. The newest one is Extended Input Output Model for the Nuclear Power Plant Impact Assessment (Empower) which was firstly developed under the IAEA Common Research Project (CRP) 12005 on "Assessing the National and Regional Economic and Social Effects of Nuclear Programmes" (Kratena and Voigt. 2017). The version for Poland is called Empower.PL. The Empower model consists of two components:

- equation system (a theoretical or empirical model), showing basic multiplier mechanisms occurring within the national economy,
- software for implementing and solving the empirical model, in the form of MS Excel files containing calculation templates and associated Visual Basic for Applications (VBA) programs for running the model.

In this section we present the general characteristics of the *Empower* model whereas in the next section we present preliminary results of its use for the model for estimating the effects of the construction of NPP in Poland. The model proposed for the assessment of the effects of the construction and operation of the NPP presented by consists of the sets of equations presented here in Table 1. The equations presented constitute the full version of the model, reflecting the four types of multiplier mechanisms present in the economy, resulting from the following relationships described by the theory of economics.

- a) interindustry (direct and indirect) - equations (1)**Error! Reference source not found.** and (2),
- b) incomes and consumption - equations (3) and (4),
- c) employment (unemployment), wages and prices - equations (5)-(8)
- d) public sector income revenues and investments - equation (9)

*Table following on the next page*

Table 1: Equations of Empower model (Own elaboration)

Equations	Symbols
Output (in current nominal terms): $\mathbf{x} = \mathbf{A}^d \mathbf{x} + \mathbf{c}p + \mathbf{f}^* + \mathbf{f}^{new}$ (1)	<p><i>Variables</i></p> <p>x output;                      cp household consumption;                      f final use (excluding household consumption);                      p output prices;                      w wage rate;                      YD disposable income (after tax);                      YD<sub>oth</sub> non-wage income;                      L employment;                      LF labour force;  <math>t_{hh}^{new}</math> revenue-neutral tax rate.</p> <p><i>Symbols written with variables in the upper or lower index:</i></p> <p>r in real terms;                      d domestic;                      m foreign;                      * original data;                      base in base year.</p> <p><i>Parameters</i></p> <p>l unit labour costs;                      s unit operational surplus;                      A Matrix of input-output coefficients;                      t<sub>hh</sub> household tax rate;                      f<sub>s, hh</sub> coefficients for harmonization of operational surplus in input=output tables and national accounts;                      f<sub>w, hh</sub> coefficients for harmonization of wages in input=output tables and national accounts;                      const constant term;                      elas income elasticity;                      β<sub>ur</sub> parameter of wage response to unemployment rate.</p> <p><i>Other symbols</i></p> <p>log natural logarithm;                      exp exponential function;                      i unit vector;                      ' symbol of transposition;</p> <p>Bold text indicates the vectors containing the appropriate sectoral values.</p>
Output (in real terms) $\mathbf{x}^r = \mathbf{x} / \mathbf{p}$ (2)	
Disposable income: $YD = l w f_{w, hh}^f (1 - t_{hh}) \mathbf{x} + s f_{s, hh}^f (1 - t_{hh}) \mathbf{x} + YD_{oth}$ (3)	
Consumption (in current prices): $\mathbf{c}p = [\exp(const_{cp} + elas(\log(YD)))] \mathbf{b}_{hh}^d$ (4)	
Employment: $L = \mathbf{l} \mathbf{x}^r$ (5)	
Wages: $w = \exp(const_w + \beta_{ur} \log(1 - L/LF))$ (6)	
Unit labour costs: $\mathbf{l} = \mathbf{l}_{base} w / (0.5 * w_{base} + 0.5 * w)$ (7)	
Prices: $\mathbf{p} = \mathbf{p} \mathbf{A}^d + \mathbf{p}^m \mathbf{A}^m + \mathbf{l} w + \mathbf{s} + \mathbf{t}^q$ (8)	
Tax rate: $t_{hh}^{new} = \frac{r_{pub} \mathbf{i}' \mathbf{f}^{new}}{YD}$ (9)	

Technical coefficients necessary to run the model are calculated based on I-O tables in current prices. Tables for future periods are forecasted based on the assumed rates of sectoral output. In this model income flows are presented in a simplified way, as the transfers of part of primary revenues to the budget (taxes and social security burdens) and transfers from the budget to households are presented as one item - net tax burden. The net tax burden is used to designate

a total (effective) rate of tax, as uniform for all types of primary income, i.e. wages, operating surplus of households, profits and other incomes.

An analysis of the model equations indicates that there are no intertemporal relationships. This is a static model. Most of its parameters are selected using the calibration method, based on statistical data from the base period. As a result, if the empirical values of the base period are used in the scenario that determines exogenous variables, the endogenous variables at the level of their empirical values from that period will be obtained as a result of the solution of the model, reflecting the state of general equilibrium. The model is launched by a disturbance of the state of general equilibrium, by introducing an impulse, i.e. a disturbance of the value of one or more exogenous variables or one or more parameters, relative to the equilibrium state. As a result, the model determines the endogenous variables in a new equilibrium. Interpretation of results is a problem in models of such kind. It is unclear which period the new equilibrium is related to, i.e. at which point the new equilibrium is reached. Because time lapse is important in economic analysis, a simpler interpretation can be adopted with this type of model: if the impulse size is chosen to reflect changes in the value of exogenous variables between the time periods  $T$  and  $T+t$ , then the model solution determines the state of general equilibrium in the period  $T+t$ . In particular, using this approach in case of annual data, it should be recognized that if the impulse size is for one year only, the model solution concerns exactly this year. In such a case the model can be solved sequentially for subsequent periods of time for which scenarios of changes in exogenous variables have been prepared. This creates the impression of "dynamizing" the model, although in essence, the model is static. By default Empower software is configured for a classification of 35 sectors for which World Input-Output Database Release 2013 (see [www.wiod.org](http://www.wiod.org)) is available (Timmer et al., 2015). The database covers the years 1995-2011 and includes not only I-O tables but also socio-economic accounts as well as environmental data harmonized with the IO tables for 43 countries, including Poland. Taking the above into account, there was no reason to use other databases for implementing the Empower.PL. The latest table (i.e. for 2011) was used to build the model. It was decided that the model variables will be expressed in US dollars. Where source data was not available in that currency, conversions were made at the relevant exchange rate. Equations (4) and (6) contain parameters important for the performance of the Empower model – income elasticity ( $elas$ ) and wage response power for the unemployment rate ( $\beta_{ur}$ ). Usually they are estimated with econometric methods. In the Empower model, as in other models, which concentrate on the state of economic equilibrium, it is possible to determine these parameters in other ways, such as on the basis of other theories, theoretical assumptions or expert methods. In this study, the parameters were determined on the basis of suggestions by the authors of the Empower model (Kratena and Voigt, 2017), which were combined with the research of Polish authors (Bartosik and Mycielski, 2015, Utzig, 2008, Doszyń, 2004). Finally, in the simulations, the  $elas$  parameter was set to 0.8, while the  $\beta_{ur}$  parameter was set to -0.2. Model makes it possible to conduct separate simulations concerning the stage of construction of a NPP and the stage of its operation. As mentioned earlier the Empower.PL model is a static model, so the assumptions for the simulations can be adopted independently for each year. For each year the model determines the state of equilibrium. To use the model, a set of assumptions for a baseline simulation (baseline assumptions) presenting the states of equilibrium for subsequent years must be determined first. Then some disturbances (impulses) can be introduced to the baseline assumptions and solve again the model to get a disturbed simulation. The deviations of the results of the disturbed simulation from the baseline simulation show the impact of the disturbances. The baseline scenario for Empower.PL analysis was based on simulation results of "no" scenario taken from the PL-Atom (Antoszewski, 2017). This scenario determines Poland's economic growth rate until 2030 by determining the growth rate of output at current prices of each of the 35 sectors that have been distinguished in the model.

It is therefore important that both the scenario and the model do not explicitly determine the pace of inflationary processes.

If, therefore, the results of the simulation refer to changes in prices, they relate to deviations from unknown price levels formed in the base solution. It is therefore not possible to determine the inflation rates on the basis of the model results. However, one can determine to what extent the price change indices will bounce up or down from their (unknown) level from the base solution. It is also possible to cumulate and properly interpret such price changes. Accordingly, the interpretation of fixed-price variables resulting from the model solution should also be adapted to the specifics of the model. Two basic types of disturbances are introduced into the baseline scenario:

1. Increase of investment expenditures by the cost of construction of a NPP in connection with the launching of Polish Nuclear Power Program (see Ministerstwo Gospodarki, 2014) and
2. Changes in the technological structure of electricity generation, resulting in changes in input-output coefficients for the sector producing this type of energy; These breakdowns concern the stage of operation of a NPP i.e. after completion of a NPP construction and the activation of at least one nuclear unit).

An important aspect of the construction stage of a power plant, which can affect the economy, is the way of financing the construction. In the simulation scenarios, the following three funding options are considered:

- Solely from private resources (scenario labeled as prv);
- Half from private and half from public resources (scenario labeled as half);
- Solely from public resources (scenario labeled as pub)

Just as it was adopted in the PL-Atom simulation (Antoszewski, 2017), due to the fact that the most likely solution is to finance the construction of a NPP from the private sector resources (i.e. by power companies), the prv scenario should be regarded as "central" in this analysis. The construction of the scenario for the development of the Polish nuclear power industry is based on the information presented in the Polish Nuclear Power Program (see Ministerstwo Gospodarki, 2014), adopted by the Resolution of the Council of Ministers in January 2014. The program covers the period up to 2035 and envisages the construction of two power plants of up to 6000 MW (Table 2). According to this program (PPEJ), the first block, with a capacity of about 1000 MW, is to be launched in 2024, assuming that construction work will begin in 2016. It is anticipated that the completion of all blocks of the first power plant will take place by the end of 2030. The cost of its construction is estimated at 40-60 billion PLN, which is in line with current trends in construction costs of NPP (Lovering et al., 2016)

*Table 2: Assumptions of the PPEJ concerning the construction of a NPP (Own elaboration based on Ministerstwo Gospodarki, 2014)*

Issue		Assumptions of the PPEJ			
When		2020	2024	2030	2035
Power (in MW)		0	>= 1000	>= 3000	<= 6000
Technology		No			
Share of Polish funds		10%	30%	...	60%
Construction costs per MW	Power station 1 (3000 MW)	PLN 40 - 60 bln. (USD 3,3 – 5 mln.)			
	Power station 2				Commencement date and costs unknown
Operating costs		Cost classification and mapping to the sectors of the WIOD			

Costs of decommissioning, waste disposal and fuel spent	Non-explicit
---	--------------

### 3. RESULTS

According to the scenario of the construction of a NPP, it is assumed that by 2030 the NPP will have a 3000 MW target in Poland, consisting of two 1500 MW units. The first block will be launched in 2025. This investment triggers a disturbance in the baseline scenario in the years 2018-2030, when the investment outlay in the economy is increasing. The distribution of these outlays is shown in Figure 1. They rise from \$ 600 million in 2018 and reach a maximum of \$ 2,250 million in 2024. The following year, after the first NPP block run, they are almost halved and then come back down to \$ 600 million in 2030. Total expenditure is \$ 15 billion.

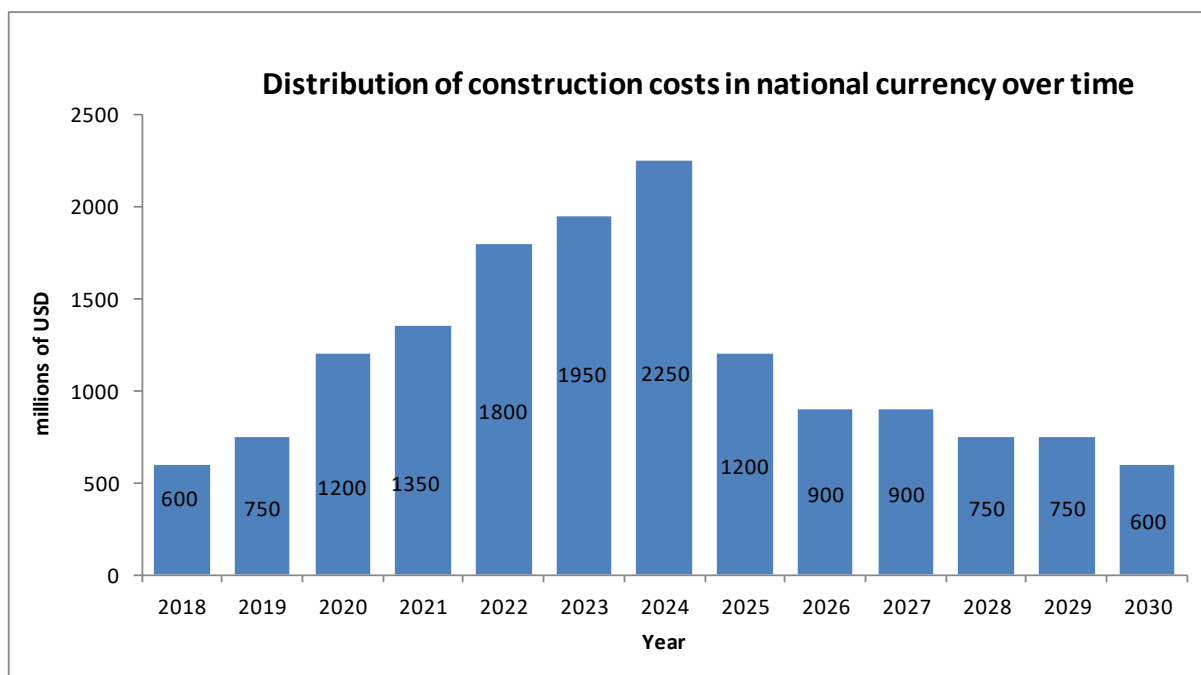

Figure 1: Distribution of expenditures for PPEJ implementation (own elaboration)

Evaluating the impact of the construction of an NPP will be restricted here to the evaluation of its impact on the macroeconomic variables. Unless otherwise stated, the presented quantities are expressed in terms of the percentage deviation of the outcome of the scenario from the base line. We will focus on comparing the nuclear scenario based on private investment (prv) versus public (pub) as well as presenting results of interim scenario (half). A set of graphs for the macroeconomic variables was considered i.e., gross domestic product (GDP), emp, gross income, personal income (PPS) and public savings (PubSav). Recall that the use of public funds in pubs and half variants would take place in a neutral manner for the public sector revenues provided for in the baseline solution. In practice, this means that tax rates should be increased to an extent to facilitate the covering of the completion costs of the next stages of PPEJ implementation using the extra revenues. In Figure 2, the deviations from the base solution are depicted. The characteristic feature of the variant graphs for the pub variant shown in Figure 2 is that, with the exception of income, they show negative deviations from the baseline - they are a kind of symmetrical reflection of the plots for the variant prv with respect to the time axis. The line denoting deviations for the half variant lays between these two.

Figure following on the next page

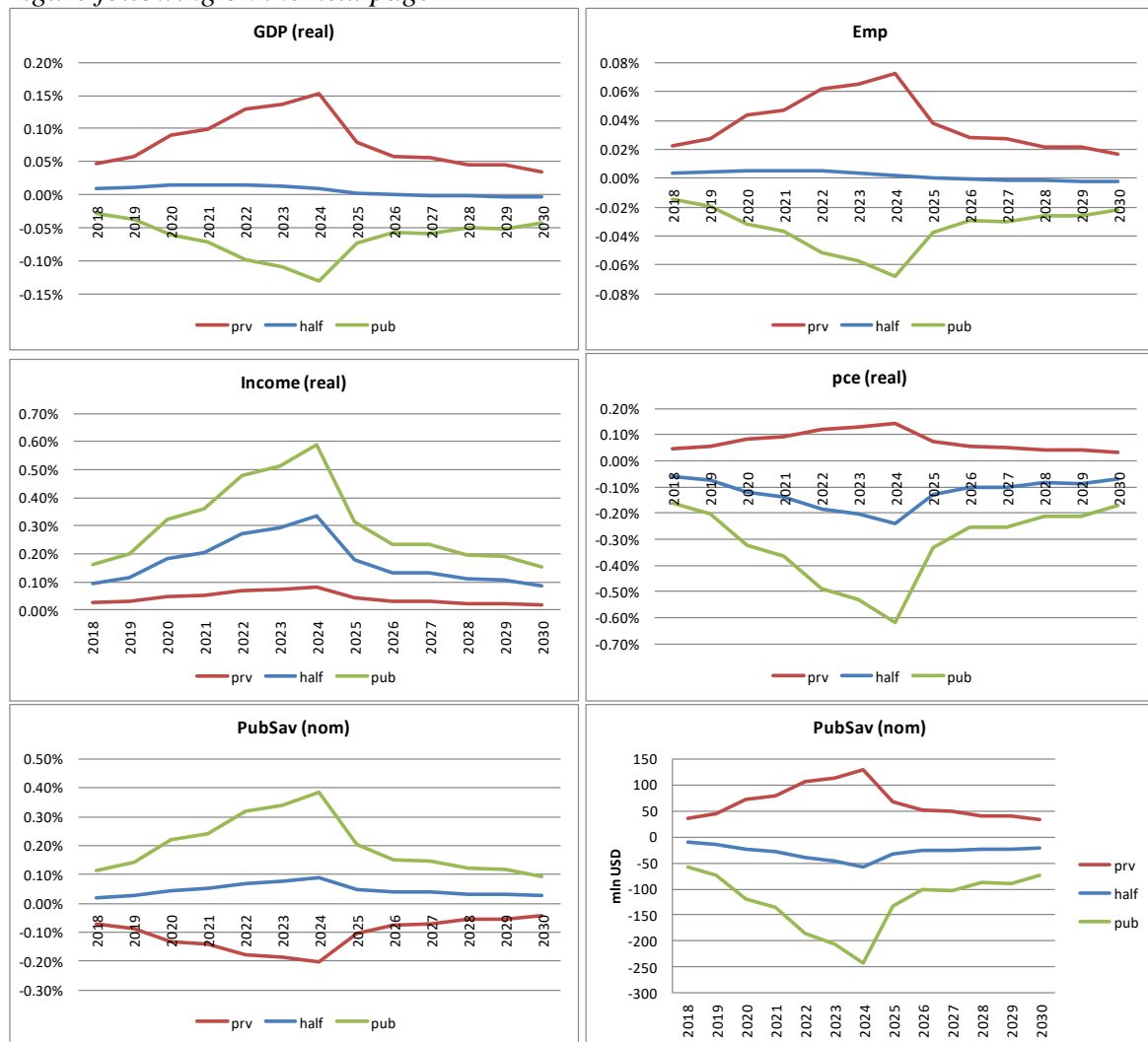

Figure 2: Results of simulation of macroeconomic variables (own elaboration)

#### 4. CONCLUSION

The general conclusion of the deviation analysis is therefore clear and quite obvious – it is better for the economy when the funds for the construction of the PPEJ come from the private sector. However, the specificity of the disturbances introduced in the **prv** variant is that the funds for investment come from the outside of the economy - these are additional measures that were not included in the baseline. If new, previously "non-existent" resources appear in the economy, it is no wonder that the economy derives additional benefits. Financing of the NPP construction from public funds, without changing the amount and structure of existing expenditures, means the need to limit and reallocate resources previously allocated (in the baseline solution) for consumption. They must be shifted and allocated to investment (consumption falls below the baseline). In the long run this can have a positive effect because additional consumption growth and gross domestic product - over the baseline solution - could be observed. However the Empower model has no built-in mechanisms that could illustrate this. Also in the case of financing of the NPP construction from private sources, the Empower model is unable to reflect some important economic mechanisms. They are connected with the so-called pushing-out effect, which results from resource constraints such as capital or labor. In the case where the limited resources are already allocated to specific tasks (the state of



equilibrium in baseline is reached), a new task, such as an NPP construction, creates the necessity of resources reallocation, and, in practice, withdrawal of some tasks that have been planned previously.

Incorporating these additional mechanisms would develop the Empower model towards more advanced Computable General Equilibrium and Multisectoral Macroeconomics Models (Almon, 1991; Plich, 2002; Bardazzi, 2013). The more general conclusion is that the forecasting of the impact of the energy sector on other areas of the economy is difficult in that the sector in itself constitutes a significant part of the economy and develops in relation to the economic cycle, other sectors of the national economy as well as the global economy. Therefore further development of the model should lead to more accurate than preliminary results presented in this paper.

**ACKNOWLEDGEMENT:** *Scientific work carried out within the Coordinated Research Project of International Atomic Energy Agency co-financed from the funds for science in the years 2014-2017 and 2016-2019 by the Polish Ministry of Science and Higher Education.*

#### **LITERATURE:**

1. Almon C. (1991). The INFORUM Approach to Interindustry Modeling. *Economic Systems Research*, Vol. 3, No. 1: 1–7.
2. Antoszewski M. (2017). *Wpływ budowy i eksploatacji elektrowni jądrowej na polską gospodarkę. Symulacje z wykorzystaniem dynamicznego modelu CGE PL-ATOM*. Paper within MAEA 18541/R2 project (mimeo).
3. Bardazzi R. (ed.) (2013). *Economic multisectoral modelling between past and future. A tribute to Maurizio Grassini a selection of writings*. Firenze University Press.
4. Bartosik K., Mycielski J. (2015). *Dynamika płac a długotrwałe bezrobocie w polskiej gospodarce*. INE PAN Working Paper Series, Paper Np. 38.
5. Blair P., Miller R. (2009). *Input-Output analysis. Foundations and Extensions*, New York: Cambridge University Press.
6. Doszyń, M. (2004). Analiza skłonności do konsumpcji dla poszczególnych rodzajów gospodarstw domowych w Polsce w latach 1993–2002, *Zeszyty Naukowe Uniwersytetu Szczecińskiego* nr 394, Prace Katedry Ekonometrii i Statystyki, Nr 15 2004, s. 51–64.
7. Kratena K., Voigt S. (2017). *An Extended Input-Output Model for Impact Assessment of Nuclear Power Plants (EMPOWER)*. Wien/Mannheim (mimeo).
8. Lovering J., Yip A., Nordhaus T. (2016). *Historical construction costs of global nuclear power reactors*. *Energy Policy* 91, 371–382.
9. Ministerstwo Gospodarki. (2014). *Program polskiej energetyki jądrowej*. Warsaw.
10. Plich M. (2002). *Budowa i zastosowanie wielosektorowych modeli ekonomiczno-ekologicznych*. Lodz University Press.
11. Stachura, P. (2018). "Energy Efficiency of Polish Economy in Years 2000-2016", *Economic and Social Development (Book of Proceedings), 35th International Scientific Conference on Economic and Social Development – "Sustainability from an Economic and Social Perspective"*, Lisbon Portugal, 15-16 November, pp. 650-657.
12. Utzig M. (2008). *Funkcje konsumpcji w krajach Unii Europejskiej*. *Zeszyty Naukowe SGGW. Ekonomika i Organizacja Gospodarki Żywnościowej* Nr 72: pp. 131-144.
13. Timmer, M. Dietzenbacher, E., Los, B., Stehrer, R. and de Vries, G. J. (2015). *An Illustrated User Guide to the World Input-Output Database: the Case of Global Automotive Production*, *Review of International Economics*, 23: 575–605.

# THEORETICAL POSSIBILITIES FOR CREATION OF ERASMUS+ PROGRAMME FOR NAVAL STUDIES AT THE UNIVERSITY OF SPLIT

**Goran Pavelin**

*University of Zadar, Croatia*

*Department of Tourism and Communication Studies*

*gpavelin@unizd.hr*

## **ABSTRACT**

*The European Union is a community of countries which was conceived by the integration of several European countries more than 50 years ago. One of the EU goals is successful foreign and security politics, achieved mostly through international cooperation. International cooperation is therefore important for strengthening of the overall EU politics and for strengthening of the sense of belonging among the EU members. Erasmus+, as a programme whose aim is to enable the youth mobility, is the best example of the EU initiative for the international cooperation. In fact, Erasmus+ is being focused on exchanges and mobility that have a positive effect on quality development of the work within young people, on strengthening of the higher education quality and on the inclusion of youth in the international business sector. Except for the above, 21st century is the time where multilingualism is necessary for successful business in each sector and organisation. Therefore, army as an institution dealing with missions outside its regional areas tends to achieve quality cooperation with other countries with a goal to prepare their cadets and officers for missions in foreign countries and for communication with the administration of countries they are located in. This paper analyses study programmes of prominent EU members with which the Naval Studies in Split plans to cooperate. The author recommends introduction of Erasmus+ courses in Naval Studies programme after the comparison of the existing study programme and Erasmus+ courses on universities and academies within the EU.*

**Keywords:** *European Union, international cooperation, Erasmus+, naval studies, University of Split*

## **1. INTRODUCTION**

In 1973, Denmark, Ireland and United Kingdom joined the so called European Economic Community (EEC). The then commissioner of the European Economic Community, Altiero Spinelli, considered that two things were crucial for opened and democratic Europe: quality education and cultural dimension. At his initiative, the European Commission opened the first Educational and Youth Department, regardless of the fact that education was not a priority of this political movement. Three years later, European ministers of education accepted the proposal of the notable European Commission member Hywel Ceri Jones (who developed the European Education Cooperation). This proposal was based on his experience at the University of Sussex. As a matter of fact, students of this University were able to spend an academic year abroad and to integrate passed exams in their "home programme" regardless their study programme. This idea was proposed at European level. Demonstration process and pilot study lasted 10 years. During these years, they were supposed to include all of the universities in Europe in this programme and to establish all of the legal and financial basics necessary for the European Union to develop such an educational cooperation and to launch Erasmus programme (ERASMUS Creating Opportunities for The UK Across Europe, 2017). Finished and elaborated Erasmus programme (European Region Action Scheme for the Mobility of University Students) was finally launched in 1987 and since that moment it enabled student mobility in 33 countries. The duration of the Erasmus programme is from 3 to 12 months for each student.

During that period students leave their study programme and attend lectures in another university abroad. Lectures attended abroad on another university are being acknowledged at the home university and students do not bear any additional costs. One of the biggest advantages of the Erasmus programme is the inclusion of students in disadvantaged positions and those having fewer opportunities in comparison with their peers. Except for the above, Europe is seeking multilingualism with the goal to be united regardless cultural and linguistic differences. Therefore, knowledge of a large number of languages and adoption of communication skills open broader business opportunities for students (European Council, Council of the European Union, 2017). Erasmus+ is the programme launched by the European Union, which includes all of the European and international programmes and initiatives of the EU. It is a programme created for the education, training, youth and sport which was launched in 2014 and will last until 2020. It is particularly focused on connection of the youth with the business sector. This programme replaced seven other programmes existing between 2007 and 2013. Erasmus + offers mobility for individuals and international cooperation between organisations through: conducting part of the studies abroad, conducting professional practice, professional training, volunteering, youth exchange and work on international projects. Programme itself is structured according to five key activities: (1) Mobility with the purpose of learning for individuals, (2) Cooperation for innovations and exchange of good practice, (3) Support to the reform politics, (4) Jean Monnet programme and (5) Sport (Erasmus +: General information). In 2008, EMILYO - European Initiative for the exchange of young officers – was launched and inspired by Erasmus. The main goal of this programme is the development of exchanges between armed forces and future officers (European Security and Defence College (ESDC), 2018).

## **2. COMPARISON OF ERASMUS+ PROGRAMME WITHIN NAVAL STUDIES PROGRAMMES IN EU MEMBER COUNTRIES**

University of Defence in Czech Republic is the only military higher education institution of Czech armed forces. University of Defence was opened on September 1<sup>st</sup> 2004 through the merging of three previously existing institutions: Military Academy in Brno, Military Ground Forces University in Vyskov and Military Academy for Medicine in Hradec Kralove. University consists of three faculties: (1) Faculty of military leadership, (2) Faculty of military technology and (3) Faculty of health studies and three “centres”: (1) Centre for safety and military strategy studies, (2) Centre for languages and (3) Centre for physical training and sports (University of Defence in Brno, Essential facts of the university, 2018). University provides education on undergraduate, graduate and postgraduate level in areas of military management, economy, engineering or health care. Also, University aims to ensure the education on the basis of recent researches and changes in the army on national and international scale. In this way, they prepare students for NATO’s missions outside of Czech Republic (University of Defence in Brno, University scope, 2018). University offers Erasmus programme on undergraduate, graduate and postgraduate level, assuming a signed agreement between the University in Brno and student’s home institution prior to his arrival (University of Defence in Brno, Study at the University of Defence in a framework of Erasmus, 2018). Students arriving at the University within Erasmus programme can attend lectures in English on three faculties (Military leadership, Military technology and Military health sciences). At the Faculty of Military leadership students attend lectures held in English and they can choose maximum two of four offered languages (English, German or Russian and Czech language). In academic year 2018/2019 they attend 16 courses in English: (1) Accounting, (2) Economy 1: Micro economy, (3) Elements of law and international humanitarian law, (4) Engineering support within NATO, (5) Engineering and armaments (originally Technical support and weapon), (6) IT logistics support, (7) Leadership, (8) Operational research: Basics, (9) Fire control, (10) Public economy, (11) Statistics, (12) Foreign language I (English), (13) Foreign language II (German/Russian),

(14) Foreign language III (Czech), (15) Foreign language IV (Business English) and (16) Physical education and sports. University has two rules for the choice of languages: (1) Student chooses only one among offered languages and (2) Student can choose two languages in combination that suits him. Also, students pass exams in chosen languages and based on its results they are being places in beginner, intermediate and advanced level groups (Faculty of Military Leadership, 2018). At the Faculty of Military Technology students can use Erasmus on their undergraduate and postgraduate studies (Faculty of Military Technology, University of Defence in Brno, Students mobility, 2018). In addition, foreign students have the possibility of accommodation in a dorm, but the capacity of a dorm is limited. At the undergraduate level, Faculty offers 20 courses and some of them require preknowledge. It is necessary for six courses: (1) Mathematics II (preknowledge in Mathematics Basics required), (2) Advanced thermodynamics (preknowledge in Thermodynamics Basics), (4) Military optical devices (preknowledge in Mathematics and Physics), (5) English (at least B1 level required) and (6) German or Russian (minimum A2 level required). Preknowledge is not required for following courses: (1) Airforce strategies, (2) Air traffic control procedure and aeronautical law, (3) Flight planning, (4) Management of air traffic control and aircraft engines, (5) Mechanics of aircraft structure and Avionics and control systems, (6) Radar technology: basics, (7) Signals and systems, (8) Operational systems, (9) Computer networks, (10) Data and telecommunication network, (11) Czech language and (12) Physical education and sports (Faculty of Military Technology, University of Defence in Brno, Erasmus+ Offer for spring/summer semester of Academic Year 2018/2019, 2018). Faculty of Military Technology offers a choice among 9 branches to foreign postgraduate students: (1) Aircraft and rocket technology, (2) Communication and information systems, (3) Electronic systems and devices, (4) Engineering cybernetics and mechatronics, (5) Materials and technological engineering, (6) Military geography and meteorology, (7) Military structures, (8) Transport machines and equipment and (9) Weapons and ammunition (Faculty of Military Technology, University of Defence in Brno, Erasmus Summer Term at Faculty of Military Technology, 2018). Poland has a long history of student exchange. Between 1979 and 1986, Polish Naval Academy was a host to Libyan students. 133 of them graduated at the Academy, as well as 44 Vietnamese students in 1991. Three students from North Korea spent one semester at the Academy, while three students from Latvia studied with Polish cadets in the first half of 21st century. Briefly, 180 foreign students graduated at the Academy in the mentioned period of time, while the most numerous and culturally most prominent were those from Libya. When Poland joined NATO in 1999, foreign students were able to participate in different trainings. In 2015 internalisation of the Academy increased and today it cooperates with 19 universities from 14 countries who participate in Erasmus programme for the exchange of students and staff. 14 countries with which Polish Naval Academy cooperates are: (1) Croatia, (2) Czech Republic, (3) Bulgaria, (4) Estonia, (5) Greece, (6) Spain, (7) Lithuania, (8) Malta, (9) Germany, (10) Portugal, (11) Romania, (12) Slovakia, (13) Sweden and (14) Turkey (Polish Naval Academy of the Heroes of Westerplatte, Foreign students). Polish Naval Academy consists of four faculties: (1) Faculty of Navigation and Navigation Weapon, (2) Faculty of Mechanical and Electronic Engineering, (3) Faculty of Command and Naval Operations and (4) Faculty of Humanities and Social Sciences. Those four faculties offer undergraduate and graduate education and a dozen postgraduate studies which last two semesters. Faculty of Navigation and Navigation Weapon comprises two fields: IT and Navigation (Polish Naval Academy of the Heroes of Westerplatte, Course Catalogue). Within Erasmus programme in the field of IT, foreign students must choose 4-5 courses before the beginning of a chosen semester and must have minimum 30 ECTS at the end of semester. Choice of courses for one semester is large and all of the lectures are held in English. As a matter of fact, they are offered 16 courses: (1) Databases, (2) Wireless networks, (3) Computer vision with Python, (4) Web applications, (5) Architecture of computer systems, (6) Processing

of digital system, (7) Safety of computer systems, (8) Block chain and cryptocurrency technology, (9) Artificial intelligence, (10) Optimisation methods, (11) Object oriented programming in Java, (12) Business modelling in the unique modelling language, (13) Numeric methods, (14) Probabilistic methods, (15) International relations and (16) Cultural heritage and history of region (Polish Naval Academy of Gdynia, Faculty of Navigation and Naval weapons, Programme and plan of the first cycle degree studies, Field of study: Computer science (IT), 2018). Faculty of Mechanics and Electronic Engineering comprises Mechanical engineering and Mechatronics. In the field of Mechanical engineering, foreign students who participate in Erasmus programme can choose 5 – 6 courses among 11 offered: (1) Electronics, (2) Cooling, ventilation and conditioning on a ship, (3) Electrical engineering, (4) Marine boilers, (5) Machine design basics, (6) Engine room simulator, (7) Vibration theory, (8) Safety boat handling, (9) Military machines and equipment, (10) Poland in the EU and (11) Poland in international relations after 1989 where students must acquire at least 30 ECTS (Polish Naval Academy of Gdynia, Faculty of Mechanical-Electrical Engineering, Programme and plan of the first cycle degree studies, Field of study: Mechanical Engineering, 2018). Foreign students in the field of Mechatronics must choose 5 – 6 courses to attend among 12 offered and acquire 30 ECTS. Foreign students are divided in groups of 5 to 6 members. Following 12 courses are offered to students: (1) Engineering programming – CAD in electronic engineering, (2) Automatization basics, (3) Control engineering basics, (4) Electronic engineering, (5) Electronics, (6) Engineering programming –Matlab, (7) Microprocessors technique, (8) Engineering programming 2 – LabView, (9) Visualisation of industrial processes 1, (10) Visualisation of industrial processes 2, (11) Poland in the UE and (12) Poland in international relations after 1989 (Polish Naval Academy of Gdynia, Faculty of Mechanical-Electrical Engineering, Programme and plan of the first cycle degree studies, Field of study: Mechatronics, 2018). Faculty of Command and Naval Operations comprises only one field, National security. In winter semester foreign students are offered 11 courses: (1) Ecological safety, (2) Basics of NBC, (3) Maritime safety strategy, (4) International maritime organisations, (5) Threats in sea areas, (6) Introduction in international relations, (7) CIMIC (Civil Military Cooperation), (8) Basic of naval tactics, (9) Unmanned technologies in naval operations, (10) English and (11) Polish as foreign language. Spring semester has fewer offered courses than the winter one: (1) Introduction in law, (2) Legal aspects of crisis management, (3) Ecology basics and protection of marine environment, (4) Integrated EU maritime politics, (5) Economy and naval administration, (6) Naval safety in maritime areas, (7) International relations, (8) English and (9) Polish as a foreign language (Polish Naval Academy of Gdynia, Faculty of Command and Naval Operations, Programme and plan of the first cycle degree studies, Field of study: National Security, Specialisation track: Maritime State Security, 2018). At the Faculty of Humanities and Social Sciences we single out courses on undergraduate and postgraduate level. Foreign students attend 9 courses on the undergraduate level at the Faculty of Humanities and Social Sciences: (1) Negotiation and meditation, (2) Introduction in psychology, (3) Philosophical basics of education, (4) Political geography and geopolitics, (5) International protection of the human right law, (6) Globalisation and regionalisation, (7) International safety, (8) Modern religions and safety and (9) Interpersonal communication. An equal number of courses is offered on postgraduate level: (1) Philosophy of education, (2) Preschool pedagogy, (3) Science of state and law (4) Priorities of global geopolitics, (5) Political geography and geopolitics, (6) International politics relations, (7) International safety, (8) History of political ideas, (9) Political philosophy (Polish Naval Academy, Faculty of Humanities and Social Sciences. Courses Offer 2017/2018 Faculty of Humanities and Social Science). Naval Academy “Mircea cel Batran” in Romania offers undergraduate education to foreign students on four faculties: (1) Navigation and Maritime Transport, (2) Maritime and Port Engineering and Management, (3) Electronical Engineering and (4) Naval Electro

mechanics. The list of courses offered to Erasmus students has been published for this academic year. Faculty of Navigation and Maritime Transport offers five courses on the first year: (1) Coastal navigation I and (2) IT application I in fall semester and (3) Technical drawing, (4) Coastal navigation II and (5) IT application II in spring semester. On second year in fall semester students attend four courses: (1) Special chapters in mathematics, (2) Statics of the ship and stability, (3) Air navigation I and (4) Maritime English I. In spring semester they attend six courses: (1) Numerical methods, (2) Material strength, (3) Ship dynamics and shipbuilding, (4) Air navigation, (5) Navigational hold and guard and (6) Maritime English II. On the third year in fall and spring semester they attend a total of seven courses. Courses in fall semester are: (1) Electronics, (2) Meteorology and oceanography I, (3) Automatic control, (4) Naval communication, (5) Radar navigation, (6) Maritime English III and (7) Navigational equipment and systems I, and in spring semester: (1) Meteorology and oceanography II, (2) Radar navigation II, (3) Maritime transport I, (4) Ship handling I, (5) Maritime English IV, (6) Navigational equipment and systems II and (7) Naval machines and equipment. On the fourth year students have significantly fewer courses, therefore in fall semester they attend: (1) Management and marketing, (2) Maritime transport, (3) Navigation guard II, (4) Ship handling II and (5) Maritime economics, while in spring semester they attend only one course: Maritime search and rescue (Mircea Cel Batran Naval Academy, Faculty for Navigation and Naval Management, Course Catalogue For Erasmus+ Program In Mircea Cel Batran Naval Academy: Navigation and Maritime Transports, 2018). At the Faculty of Naval and Port Engineering and Management on the first year students have three courses in each semester: (1) Applied computer science I, (2) Economy basics and (3) English language I (naval and port terminology) in fall, and (1) Technical drawing I, (2) Applied computer science II and (3) English language II (naval and port terminology) in spring semester. On second year in fall semester they attend four courses: (1) Special chapters in mathematics, (2) Marketing, (3) Technical drawing II and (4) English language III (business terminology), while in spring semester they attend only two courses: (1) Naval transport and port administration and (2) English language IV (business terminology). Third year consists of five courses, two in fall semester: (1) Finances and (2) Maritime law, and three in spring semester (1) Accounting basics, (2) Operational management and (3) Human resource management. On the fourth year, as well as on the first, they attend three courses in each semester: (1) Maritime economy and international navy I, (2) Project management and (3) Maritime transport in fall and (1) Maritime economy and international navy II, (2) Management of maintenance operations and (3) Entrepreneurship in spring semester (Mircea Cel Batran Naval Academy, Faculty for Navigation and Naval Management, Course Catalogue For Erasmus+ Program In Mircea Cel Batran Naval Academy: Naval and Port Engineering and Management, 2018). Faculty of Electronic Engineering on the first year has two courses in each semester: (1) Mechanics and (2) English language I in fall and (1) Maritime English language I and (2) Technical drawing in spring semester. On the second year in fall semester they attend two courses: (1) Electro technical materials and (2) Maritime English II, while in spring semester they attend four courses: (1) Theory of electric circuits, (2) Electric and electronic measures, (3) Digital electronics and (4) English language II. On third year students attend six courses; four in fall semester: (1) Electrical machines, (2) Theory of systems and automatic control I, (3) Maritime English language III and (4) Driving and auxiliary machines, and (1) Theory of systems and automatic control II and (2) Electrical drives in spring semester. On the fourth year they attend only three courses: Electronic navigation systems in spring semester and (1) Maritime electric drive systems and (2) Maritime management and marketing in spring semester (Mircea Cel Batran Naval Academy, Faculty for Marine Engineering, Course Catalogue For Erasmus + Program In Mircea Cel Batran Naval Academy: Electrical Engineering, 2018). At the Faculty of Naval Electro mechanics on the first year in fall semester they attend five courses: (1) Linear algebra, Analytical and differential

geometry I, (2) Mathematical analysis I, (3) Applied computer sciences I, (4) English I and (5) Economics basics, while in spring semester they have six courses: (1) Linear algebra, (2) Mathematical analysis II, (3) Applied informatics II, (4) Technical drawing I, (5) English II and (6) Numerical methods. On the second year in fall semester they attend only two courses, Mechanical processing and dimensional control I and Ship statics and stability, while in spring semester they have four: (1) Numerical methods, (2) Mechanical processing and dimensional control II, (3) Ship dynamics and shipbuilding and (4) Marine fuels: Emission and combustion. On the third year they attend five courses in fall semester: (1) Hydraulic and pneumatic machines, (2) Theory of automatized systems, (3) Software packages for completely automatized ships, (4) Steam systems and (5) English and five courses in spring semester: (1) Hydraulic drive, (2) Static transformers, (3) Electronic and automatized, (4) Steam and gas turbines and (5) English. On the fourth year they attend four two-semester courses: (1) Technology of maintenance and reparation of machines and ship systems, (2) Maritime systems of cooling and conditioning and (3) Maritime mechanical and hydropneumatic systems, and in spring semester three additional courses: (1) Technologies of maintenance and reparation of machines and ship systems, (2) Auxiliary cooling and conditioning systems and (3) Maritime mechanical and hydropneumatic systems, while in spring semester they have three additional courses: (1) Safety and protection of a ship, (2) Control systems for machines and ship system and (3) Engine room guard (Mircea Cel Batran Naval Academy, Faculty for Navigation and Naval Management, Course Catalogue For Erasmus+ Program In Mircea Cel Batran Naval Academy: Naval Electromechanics, 2018). Study programme at the National Military University in Hungary consists of four faculties: (1) Faculty of Public Management and Administration, (2) Faculty of International and European Studies, (3) Faculty of Military Sciences and Officer Training and (4) Faculty of Law Enforcement. Foreign students coming to the University through Erasmus programme can choose courses from one of the modules, given how similar it is to the "home" programme. Faculty of Public Management and Administration has two modules: (1) Public Management and Political Sciences and (2) Public Administration and Management (National University of Public Service, Course Catalogue 2018/19, 2018). Public management and political sciences module offers two courses in fall semester: Corporation management and History of European Politics, nine courses in spring semester: (1) Collision of basic rights, (2) Comparative parliamentary studies, (3) Formation of the constitution and state building, (4) Challenges of contemporary management and sustainable political reactions, (5) Contemporary political opinion, (6) Introduction in political sciences, (7) Nationalism, nation, state and multiculturalism, (8) Public management and administration – from the international perspective and (9) Strategic management in historical comparative context. In both fall and spring semester 9 courses are offered: (1) Democratic transitions in Middle and Eastern Europe, (2) Diversity, equity, inclusions, (3) European legal history, (4) Good administration – international dimensions, (5) Hungarian historical constitution, (6) Parliamentarism and forms of democratic participation in Middle and Eastern Europe, (7) Public diplomacy, (8) National constitutions of economic management and (9) Theories of state and administration – challenges and perspectives (National University Of Public Service, Public Governance and Political Sciences, 2018). Module Public administration and management consists of five fall semesters: (1) Protection of Hungarian heritage, (2) Intercultural communication and diversity management, (3) Local administration, (4) Public management and (5) Communication of public service, four in spring semester: (1) Management of changes in public sector, (2) Comparative administration law, (3) Introduction in public politics and (4) Organisation of Hungarian state and seven courses conducted in fall and spring semester: (1) Challenges of public administration, (2) Efficiency problems of *fragile* state, (3) Management knowledge in public organisations, (4) Manager ethics and ethical leadership in public organisations, (5) Political communication in IT society, (6) Project

management – general principles and application of IT systems and (7) Regional geography and economy of European states (National University Of Public Service, Public Administration and Management, 2018). Faculty of International and European studies within Erasmus offers only one module, Module of international relations on undergraduate and graduate level. For academic year 2018/2019 a module for spring semester of graduate studies was offered, but all of the foreign students who choose Module of international relations can attend courses of graduate level, regardless the level of their previous education. There are 13 mandatory courses and they are all conducted in English: (1) Intercultural communication, diversity management, (2) Challenges of regional safety, (3) International and European cooperation in law enforcement, (4) Sector politics of EU, (5) Employment of workforces, collaborative and collective efforts, (6) Innovation, ICT, E-Public service and Safety information, (7) Common foreign and security politics of the EU, (8) Use of force and international law, (9) History of NATO, (10) American foreign and security politics, (11) International institutions, (12) Public law of EU and (13) Sector politics of the EU (National University Of Public Service, Course Catalogue 2018/19: Faculty of International and European Studies, 2018). Faculty of Military Sciences and Officer Training has three modules, of which only one was offered to foreign students in spring semester of academic year 2018/2019: Module of military leadership. Module of military leadership for the undergraduate level has 16 courses: (1) Transition from military to civil life, (2) Freedom of Worship Limited, (3) Hungarian military law, (4) Law of forced engagement, (5) Training of NATO military personnel, (6) Financial basics, (7) Defence Economics, (8) Mathematics and probability, (9) Military leadership during the Cold War, (10) Management of information security risk, (11) Map reading and ground navigation, (12) Terrain and field analysis, (13) Aspects of war asymmetry, (14) Safety basis of opened network sources, (15) Logistics and (16) Management of supply chain – SCOR. Graduate studies of modules consists of two courses offered only on graduate level: (1) Law of armed conflicts and military occupations and (2) Theory of allied joined actions and of eight courses offered on undergraduate and graduate levels: (1) War and ethics (Ethical leadership in war): Historical and contemporary problems, (2) War and ethics (Ethical leadership in a war): Contemporary, (3) Aspects of war asymmetry, (4) Theories of rebellion and its suppression, (5) Safety and geography, (6) Professional English as a foreign language (for cadets), (7) Crossover Hungary – Flavours of Hungarian Culture and (8) Military sports (National University Of Public Service, Course Catalogue 2018/19: Faculty of Military Sciences and Officer Training, 2018). Faculty of Law Enforcement has one module: Module of law enforcement. Module consists of 13 courses: (1) Studies of international and European law – Police and judicial cooperation, (2) International and European migration, (3) Law enforcement and safety studies on Schengen Agreement, (4) Public safety – Private safety, (5) Criminal psychology, (6) Theory of leadership and management, (7) Police physical and health culture, (8) Tax and customs as regulatory instruments in economy, (9) Police secret missions, (10) Victimology, (11) History of law enforcement, (12) Professional foreign language: English, German, Russian and (13) Hungarian for beginners (National University Of Public Service, Course Catalogue 2018/19: Faculty of Military Sciences and Officer Training, 2018).

### **3. RECOMMENDATIONS FOR INTRODUCTION OF NEW ERASMUS + COURSES AT THE UNIVERSITY OF SPLIT IN REGARD TO THE CONDUCTED ANALYSIS**

On the website of the University of Split there is no information on implemented Erasmus + courses, because the author states that the website is still under construction. Therefore, based on previous comparisons within EU members, the author makes his independent recommendation which could be used as theoretical ground for the University of Split to start with the planed study introduction in the form of frequent and fruitful knowledge and experience exchange with students of other countries.



Comparison of courses at Naval studies in Split (Pavelin, 2018, p. 831-840) with Erasmus+ courses of previously mentioned EU members shows that other countries have better developed study programme, especially due to the wider range of science application. Therefore, recommendation for introduction of Erasmus+ courses at Naval studies in Split is led by the difference among all of the existing courses at Naval studies programme and among those offered on faculties and academies in mentioned countries. Considering these differences, we recommend the introduction of following courses. Lectures and practice from following courses:

- According to the Erasmus+ courses at the University of Defence in Czech Republic;
  - (1) Naval legislation
  - (2) Statistics
  - (3) Thermodynamics
  - (4) Accounting
  - (5) Economy
  - (6) Basics of Croatian language
- According to the Erasmus+ courses at the Polish Naval Academy;
  - (7) International relations
  - (8) Cooling, ventilation and conditioning on a ship,
- According to courses of the Naval Academy „Mircea cel Batran“ in Romania
  - (10) Statics of a ship
  - (11) Hydraulic and pneumatic machines,
- According to the National Military Service University in Hungary
  - (12) Naval politics in the EU.

#### 4. CONCLUSION

Main goals of the international student exchange are: (1) Preparation of students for the European labour ,market needs, (2) Enabling the development of language competences for students and understanding of economic and social culture of a country in a context of professional experience, (3) Promotion of the cooperation among companies and higher education institutions and (4) Contribution to the society through the education of experienced, open minded and professional youth (Cvikl, Artič, 2013). Since the academic year 2018/19 Naval Studies in Split offer to their students the exchange possibility within Erasmus and Emilyo in Austria, Belgium, Bulgaria, Hungary, Romania, Czech Republic and Poland (Hina, 2018). Study programmes of Erasmus+ courses in Czech Republic, Poland, Romanian and Hungarian military academies are elaborated in details and shown with all of the necessary information for coming foreign students. On the other side, the website of Naval Studies in Split which should offers information on Erasmus+ courses is under construction. Therefore, based on the differences among existing courses at Naval Studies and Erasmus+ courses in mentioned EU members the author recommends the introduction of courses that the Naval Studies could include in their international exchange programme. He recommends introduction of 12 courses, of which 6 according to the model of Erasmus+ programme at the University of Defence in Czech Republic: (1) Naval legislation, (2) Statistics, (3) Thermodynamics, (4) Accounting, (5) Economy, (6) Basics of Croatian language, two according to the model of Polish Naval Academy: (1) International relations and (2) Cooling, ventilation and conditioning of a ship, two according to the Naval Academy in Romania: (1) Statics of a ship and (2) Hydraulic and pneumatic machines, and one according to the model of the National Military Service University in Hungary: Naval politics in the EU.

## LITERATURE:

1. THE AGENCY FOR MOBILITY AND EU PROGRAMMES. *Erasmus + :General information*. Taken on 22/11/2018 from: <http://www.mobilnost.hr/hr/sadrzaj/erasmus-opce-informacije/>.
2. Cviki, H., Artič, N. (2013). *Can mentors of Erasmus student mobility influence the development of future tourism?*. Taken on 24/11/2018 from: <https://hrcak.srce.hr/file/152973>.
3. ERASMUS Creating Opportunites for The UK Across Europe (2017). *Origins of the Erasmus programme – interview with Hywel Ceri Jones*. Preuzeto 22.11.2018. Taken from: <https://www.erasmusplus.org.uk/blog/origins-of-the-erasmus-programme-%E2%80%93-interview-with-hywel-ceri-jones>.
4. European Council, Council of the European Union (2017). *Celebrating 30 years of the Erasmus Programme*. Taken on 22/11/2018 from: <https://www.consilium.europa.eu/en/documents-publications/library/library-blog/posts/celebrating-30-years-of-the-erasmus-programme/>.
5. European Security and Defence College (ESDC) (2018). *The European Initiative for the Exchange of Young Officers (EMILYO)*. Taken on 22/11/2018 from: [https://eeas.europa.eu/topics/external-investment-plan/45566/european-initiative-exchange-young-officers-emilyo\\_en](https://eeas.europa.eu/topics/external-investment-plan/45566/european-initiative-exchange-young-officers-emilyo_en).
6. Faculty of Military Leadership (2018). *Course plan for winter semester of academic year 2018/2019*. Taken on 22/11/2018. from: [https://www.unob.cz/en/fml/study/Documents/ERASMUS\\_PLUS\\_STUDY\\_OFFER.pdf](https://www.unob.cz/en/fml/study/Documents/ERASMUS_PLUS_STUDY_OFFER.pdf)
7. Faculty of Military Technology, University of Defence in Brno (2018). *Erasmus+ Offer for spring/summer semester of Academic Year 2018/2019*. Taken on 22/11/2018. from: [https://www.unob.cz/en/fmt/study/Pages/bachelor\\_studies.aspx](https://www.unob.cz/en/fmt/study/Pages/bachelor_studies.aspx).
8. Faculty of Military Technology, University of Defence in Brno (2018). *Erasmus Summer Term at Faculty of Military Technology*. Taken on 22/11/2018. from: [https://www.unob.cz/en/fmt/study/Pages/doctorate\\_studies.aspx](https://www.unob.cz/en/fmt/study/Pages/doctorate_studies.aspx).
9. Faculty of Military Technology, University of Defence in Brno (2018). *Students mobility*. Taken on 22/11/2018 from: [https://www.unob.cz/en/fmt/study/Pages/students\\_mobility.aspx](https://www.unob.cz/en/fmt/study/Pages/students_mobility.aspx)
10. Hina (2018). *Krstičević: Hrvatska vojska treba obrazovanog časnika 21. stoljeća*. Taken on 24/11/2018. from: <https://www.glasistre.hr/hrvatska/krsticevic-hrvatska-vojska-treba-obrazovanog-casnika-21-stoljeca-574228>.
11. Mircea Cel Batran Naval Academy, Faculty for Marine Engineering (2018). *Course Catalogue For Erasmus+ Program In Mircea Cel Batran Naval Academy: Electrical Engineering*. Taken on 22/11/2018 from: [https://www.anmb.ro/eng/files/ri/incoming\\_students/Erasmus%20courses%20in%20MBNA%202018-2019.xlsx](https://www.anmb.ro/eng/files/ri/incoming_students/Erasmus%20courses%20in%20MBNA%202018-2019.xlsx).
12. Mircea Cel Batran Naval Academy, Faculty for Navigation and Naval Management (2018). *Course Catalogue For Erasmus+ Program In Mircea Cel Batran Naval Academy: Naval and Port Engineering and Management*. Taken on 22/11/2018 from: [https://www.anmb.ro/eng/files/ri/incoming\\_students/Erasmus%20courses%20in%20MBNA%202018-2019.xlsx](https://www.anmb.ro/eng/files/ri/incoming_students/Erasmus%20courses%20in%20MBNA%202018-2019.xlsx).
13. Mircea Cel Batran Naval Academy, Faculty for Navigation and Naval Management (2018). *Course Catalogue For Erasmus+ Program In Mircea Cel Batran Naval Academy: Naval Electromechanics*. Taken on 22/11/2018 from: [https://www.anmb.ro/eng/files/ri/incoming\\_students/Erasmus%20courses%20in%20MBNA%202018-2019.xlsx](https://www.anmb.ro/eng/files/ri/incoming_students/Erasmus%20courses%20in%20MBNA%202018-2019.xlsx).

14. Mircea Cel Batran Naval Academy, Faculty for Navigation and Naval Management (2018). *Course Catalogue For Erasmus+ Program In Mircea Cel Batran Naval Academy: Navigation and Maritime Transports*. Taken on 22/11/2018 from: [https://www.anmb.ro/eng/files/ri/incoming\\_students/Erasmus%20courses%20in%20MBNA%202018-2019.xlsx](https://www.anmb.ro/eng/files/ri/incoming_students/Erasmus%20courses%20in%20MBNA%202018-2019.xlsx).
15. National University Of Public Service (2018). *Course Catalogue 2018/19*. Taken on 22/11/2018 from <https://en.uni-nke.hu/education/exchange-studies/course-catalogue>.
16. National University Of Public Service (2018). *Course Catalogue 2018/19: Faculty of International and European Studies: FIES\_SPRING.xlsx* Taken on 22/11/2018 from: <https://en.uni-nke.hu/education/exchange-studies/course-catalogue>.
17. National University Of Public Service (2018). *Course Catalogue 2018/19: Faculty of Law Enforcement: FLE\_SPRING.xlsx* Taken on 22/11/2018 from: <https://en.uni-nke.hu/education/exchange-studies/course-catalogue>.
18. National University Of Public Service (2018). *Course Catalogue 2018/19: Faculty of Military Sciences and Officer Training: FMSOT\_SPRING.xlsx* Taken on 22/11/2018 from: <https://en.uni-nke.hu/education/exchange-studies/course-catalogue>.
19. National University Of Public Service (2018). *Public Administration and Management*. Taken on 22/11/2018 from: <https://akk.uni-nke.hu/nemzetkozi-kapcsolatok/oktatas-idegenyelveken/module-2>.
20. National University Of Public Service (2018). *Public Governance and Political Sciences*. Taken on 22/11/2018 from <https://akk.uni-nke.hu/nemzetkozi-kapcsolatok/oktatas-idegenyelveken/module-1>.
21. G. Pavelin (2018). *PRIKAZ KOMUNIKACIJSKIH DISCIPLINA U VOJNOPOMORSKIM STUDIJIMA NA PODRUČJU EU*. Taken on 24/11/2018 from: [http://www.esd-conference.com/upload/book\\_of\\_proceedings/Book\\_of\\_Proceedings\\_esdLisbon2018\\_Online.pdf](http://www.esd-conference.com/upload/book_of_proceedings/Book_of_Proceedings_esdLisbon2018_Online.pdf).
22. Polish Naval Academy, Faculty of Humanities and Social Sciences . *Courses Offer 2017/2018 Faculty of Humanities and Social Science*. Taken on 22/11/2018 from: [https://www.amw.gdynia.pl/images/AMW/Uzytkownicy/Erasmus\\_/catalog\\_courses/syllabus\\_Erasmus\\_FACULTY\\_OF\\_HUMNITIES\\_AND\\_SOCIAL\\_SCIENCES.pdf](https://www.amw.gdynia.pl/images/AMW/Uzytkownicy/Erasmus_/catalog_courses/syllabus_Erasmus_FACULTY_OF_HUMNITIES_AND_SOCIAL_SCIENCES.pdf).
23. Polish Naval Academy of Gdynia, Faculty of Command and Naval Operations (2018). *Programme and plan of the first cycle degree studies, Field of study: National Security, Specialisation track: Maritime State Security*. Taken on 22/11/2018 from: [https://www.amw.gdynia.pl/images/AMW/Uzytkownicy/Erasmus\\_/catalog\\_courses/Programme\\_ERASMUS-national\\_security.pdf](https://www.amw.gdynia.pl/images/AMW/Uzytkownicy/Erasmus_/catalog_courses/Programme_ERASMUS-national_security.pdf).
24. Polish Naval Academy of Gdynia, Faculty of Navigation and Naval weapons (2018). *Programme and plan of the first cycle degree studies, Field of study: Computer science (IT)*. Taken on 22/11/2018 from: [https://www.amw.gdynia.pl/images/AMW/Uzytkownicy/Erasmus\\_/catalog\\_courses/Programme\\_ERASMUS\\_IT.pdf](https://www.amw.gdynia.pl/images/AMW/Uzytkownicy/Erasmus_/catalog_courses/Programme_ERASMUS_IT.pdf).
25. Polish Naval Academy of Gdynia, Faculty of Mechanical-Electrical Engineering (2018). *Programme and plan of the first cycle degree studies, Field of study: Mechanical Engineering*. Taken on 22/11/2018. from: [https://www.amw.gdynia.pl/images/AMW/Uzytkownicy/Erasmus\\_/catalog\\_courses/Programme\\_ERASMUS\\_Mechanical\\_Engineering\\_AZF.pdf](https://www.amw.gdynia.pl/images/AMW/Uzytkownicy/Erasmus_/catalog_courses/Programme_ERASMUS_Mechanical_Engineering_AZF.pdf).
26. Polish Naval Academy of Gdynia, Faculty of Mechanical-Electrical Engineering (2018). *Programme and plan of the first cycle degree studies, Field of study: Mechatronics*. Taken on 22/11/2018 from: [https://www.amw.gdynia.pl/images/AMW/Uzytkownicy/Erasmus\\_/catalog\\_courses/Programme\\_ERASMUS\\_Mechatronic\\_AZF.pdf](https://www.amw.gdynia.pl/images/AMW/Uzytkownicy/Erasmus_/catalog_courses/Programme_ERASMUS_Mechatronic_AZF.pdf).

27. Polish Naval Academy of the Heroes of Westerplatte. *Course Catalog*. Taken on 22/11/2018 from:  
<https://www.amw.gdynia.pl/index.php/en/erasmus-for-foreigner/item/2140-course-catalog#faculty-of-navigation-and-naval-weapons>.
28. Polish Naval Academy of the Heroes of Westerplatte. *Foreign students*. Taken on 22/11/2018 from: <https://www.amw.gdynia.pl/index.php/en/about-us/foreign-students>.
29. University of Defence in Brno (2018). *Essential facts of the university*. Taken on 22/11/2018 from: [https://www.unob.cz/en/university/Pages/bottom\\_facts\\_university.aspx](https://www.unob.cz/en/university/Pages/bottom_facts_university.aspx).
30. University of Defence in Brno (2018). *Study at the University of Defence in a framework of Erasmus+*. Taken on 22/11./2018 from:  
<https://www.unob.cz/en/study/Pages/StudyatUniversityofDefenceinaframeworkofErasmus.aspx>.
31. University of Defence in Brno (2018). *University scope*. Taken on 22/11/2018 from:  
[https://www.unob.cz/en/university/Pages/university\\_scope.aspx](https://www.unob.cz/en/university/Pages/university_scope.aspx).

## PROTECTION OF INTELLECTUAL PROPERTY RIGHT IN POLAND

**Dominika Bochanczyk-Kupka**

*University of Economics in Katowice, Poland*  
*dominika.bochanczyk-kupka@ue.katowice.pl*

### ABSTRACT

*Intellectual property rights protection is a crucial element which contributes to the development of modern economics. Poland is considered as developed, high-income country. As a member of the European Union Poland should fulfill all high requirements and standards connected with intellectual property. The main aim of the paper is to show the assessment of intellectual protection in Poland using three measures of intellectual property protection created by well-known institutions: Property Rights Alliance, World Economic Forum and the U.S. Chamber of Commerce. In the paper brief description of their methods is also presented.*

**Keywords:** *intellectual property rights, protection of intellectual property, Poland*

### 1. INTRODUCTION

An indispensable and key element of contemporary, knowledge-based economy is an efficient and effective system of intellectual property (IP) protection. Exclusive rights for inventions, technologies, designs, trademarks, utility models geographical indications, as well as art work play a crucial role for the functioning of modern economies and organizations which create innovative environment in all spheres of economic life. Proper IP protection decides on companies profitability, have a substantial influence on the valuation of the company's assets and its market position. Right and strong intellectual property protection attract foreign investors and contribute to economic growth and development. Intellectual property rights (IPRs) are usually defined in economic terms as the rights to sell and use various creations of human mind (Bochańczyk-Kupka, 2015, p.75). According to World Intellectual Property Organization intellectual property refers to such creations of the human mind as inventions, literary and artistic works, and symbols, names, images, and designs used in commerce (WIPO, 2018). In economic literature IP is divided into two main categories: industrial property and copyright. Both of them are equally as valuable since the ramifications of not protecting these assets can be serious. Intellectual property rights are considered as policy tool to align the private returns to innovative activity with its social return, it means its benefit to society and thus to generate socially optimal incentives for private-sector innovative activity [United Nations Economic Commission for Europe 2011, p. 7].

### 2. INTELLECTUAL PROPERTY RIGHTS PROTECTION BACKGROUNDS IN POLAND

Poland has a long tradition of protecting intellectual property rights, including both: copyrights and industrial property rights. The first normative acts regarding protection of copyrights and industrial property rights date back to the 1920s. Nowadays the main legislation acts regulating intellectual property rights in Poland are The Act of 4 February 1994 on Copyright and Related Rights, and The Act of 30 June 2000 on Industrial Property Law. These Acts regulate, among others, protection of creative works and related rights, inventions, utility models, industrial designs, trademarks and geographical indications. Databases, know-how, and business secrets are also protectable under The Act of 27 July 2001 on Protection of Databases, The Act of 16 April 1993 on Combating Unfair Competition, as well as Polish civil code. There is also a number of other European and international regulations, relating to protection of intellectual property, which are effective in Poland. These Acts are consistent with the international standards of intellectual property protection arising from international treaties to which Poland

is a signatory, in particular TRIPS Agreement. Poland's accession to European Union was connected with adoption of the *acquis communautaire* including all treaties of foundation and accession as well as corresponding international agreements. By adopting international standards Poland wants to ensure strong protection of intellectual property rights

### **3. ASSESSMENT OF IP RIGHTS PROTECTION IN POLAND**

The main well-known institutions dealing with measurement, assessment and comparison of intellectual property protection are: Property Rights Alliance, (PRA) World Economic Forum and the U.S. Chamber of Commerce (the U.S. Chamber's Global Intellectual Property Center (GIPC)). Since 2007, Property Rights Alliance has been dedicated to the protection of property rights and intellectual property rights all around the world. Each year the results of its work contribute to the creation of the International Property Rights Index (IPRI). The IPRI is perceived as a indicator of the status of property rights protection around the world. There are three core components of the IPRI: Legal and Political Environment (LP), Physical Property Rights (PPR) and Intellectual Property Rights (IPR). The Legal and Political Environment (LP) component shows the strength of governance institutions in analyzed countries and the respect for national and international law. This component has a significant impact in the development and protection of physical and intellectual property rights. It presents the ability of a nation to enforce a *de jure* system of property rights and for that four items or indicators are considered: the independence of its judicial system, the strength of the rule of law, control of corruption, and the stability of its political system. The other two components of the index: Physical and Intellectual Property Rights (PPR and IPR) represent two forms of property rights. A strong property rights regime creates the confidence among people in its effectiveness to protect private property rights. It also facilitates unified transactions related to the registry of property and it allows access to the required. The Intellectual Property Rights component evaluates the protection of intellectual property. In addition to an opinion-based measure of the protection of intellectual property, it assesses protection of two major forms of intellectual property rights (patents and copyrights) from *de jure* and *de facto* perspectives, respectively. The IPRI is comprised of 10 items in total, each gathered under one of the three, mentioned before, components: LP, PPR, and IPR. While there are numerous items related to property rights, the final IPRI is specific to the core factors that are directly related to the strength and protection of physical and intellectual property rights, and the political institutions responsible for their protection. The main advantages of this measure is that the research are made in long term and that the analysis covered many countries. This was done to ensure that scores were comparable across countries and years. In 2017 Poland's IPRI score decreased by -0.16 to 6.092 and Poland ranked 7th position among countries from Central Eastern Europe and Central Asia region and 47th in the world. Poland's Legal and Political Subindex decreased by -0.34 to 5.700 with scores of 3.704 in Judicial Independence, 6.359 in Rule of Law, 6.245 in Political Stability, and 6.491 in Control of Corruption. Poland's Physical Property Rights Subindex decreased by -0.11 to 6.490 with scores of 5.112 in perception of Property Rights Protection, 8.908 in Registering Property, and 5.449 in Ease of Access to Loans. Poland's Intellectual Property Rights Subindex decreased by -0.02 to 6.088 with scores of 5.065 in perception of Intellectual Property Protection, 8.0 in Patent Protection, and 5.2 in Copyright Protection (International Property Right Index, 2018). The results of Poland in 2017 were worst in comparison with previous years. In 2016 Poland was ranked on 43<sup>rd</sup> position and in 2013 on 44<sup>th</sup> position. When comparing IPR index (table 1) in longer period, the best results Poland noted in 2007: 32<sup>nd</sup> position, and then this position deteriorated from year to year: in 2010 Poland was ranked on 33<sup>rd</sup> place, in 2013 on 35<sup>th</sup> place and in 2018 on 40<sup>th</sup> place (International Property Right Index, 2018). The evaluation of intellectual property right protection is also one of indicators used by World Economic Forum and Heritage Foundation to measure countries international

competitiveness. At the heart of the competitiveness analysis is the recognition that economic growth is a crucial driver of human development. The Global Competitiveness Index 4.0 publishes in 2018 assessed the international competitiveness of 140 economies, providing unique insight into the drivers of economic growth in the era of the Fourth Industrial Revolution. Protection of intellectual property is analyzed as a part of Institution pillar among such institutions as: security, property rights, social capital, checks and balances, transparency and ethics, public-sector performance and corporate governance. These institutions are crucial for development because they create constraints, both legal (laws and enforcement mechanisms) and informal (norms of behaviors), which organize economic activity, mainly through providing incentives and reducing uncertainties. In 2018 edition 98 indicators composed the GCI 4.0 methodology, 44 of them were sourced from the Forum's Executive Opinion Survey, and 54 were based on statistics provided by external sources suppliers [Schwab, 2018, p.42]. The indicator of intellectual property protection was created on the basis of opinion survey. The intellectual property rights protection was incorporated to the WEF competitiveness measures and to the Global Competitiveness Index in 2008. In 2018 Poland was ranked on 73<sup>rd</sup> position among 140 economies with value 4,0 and score 49,9. In 2017 Poland was placed on 72<sup>nd</sup> place among 137 countries and the value of that index was 4,0. In 2016 Poland was ranked on 72<sup>nd</sup> position among 138 countries but the value was slightly higher and equaled 4.1. In 2015 country placed on 65<sup>th</sup> position and noted the value of 4,0. In 2014 among 144 Poland took 63<sup>rd</sup> position with value of index 3,7. One year earlier, in 2013 it was classified on 72 position (among 148 countries) with index value of 3,7. In 2012 the results were respectively: 67 position among 144 countries and value 3,6. In 2011 Poland was rank on 61<sup>st</sup> position among 142 economies with score value of 3,7. In 2010 Poland obtained 60<sup>th</sup> position within 139 countries, in 2009 64<sup>th</sup> place and in 2008 it was ranked as 76<sup>th</sup> economy of 134 countries. The Global Innovation Policy Center (GIPC) of the US Chambers of Commerce released the first report in December 2012, which benchmarked 11 across five key categories representing all major forms of IP rights. Each of the five categories was broken down into specific data points for a total of 25. In 2017 the sixth edition titled "Create" was released. It described the intellectual property protection in 50 economies using 40 indicators in eight categories covering the issues connected with policy, law, regulation, and enforcement. It also provides a clear road map for economies that wishes to be competitive in the global 21st century knowledge-based economy. Poland's overall score has remained the same in the 6th edition of the Index as in the 5th edition, at 66% of the total possible score (with a score of 26.56 out of 40). This mainly reflects a stable level of protection. In that same year regional average equals 75%, and average result of top 5 economies noted 93%. Among key areas of Poland's intellectual property right protection strengths Report mention about (GIPC, 2018, p.124):

- legal framework for IP protection largely aligned with EU standards,
- certain sector-specific IP rights available (including for life sciences),
- standard legal measures for trademark and industrial design protection in place,
- increasing efforts to enhance IP policy coordination and public engagement,

The Report lists also key areas of Poland's weakness (GIPC, 2018, p.124):

- EU Commission proposal to introduce an SPC exemption for exports of biopharmaceuticals poses significant risk to Poland's and EU's research- and IP-based biopharmaceutical industry,
- gaps in the online copyright protection, including an effective notice and takedown system, though a basis for injunctive-style relief exists,
- relatively high levels of online piracy in comparison with other high-income economies,
- judicial enforcement sluggish, with lack of attention to cases of IP infringement, red tape, and generally nondeterrent penalties.

#### 4. CONCLUSION

The data and opinion presented above show that the current intellectual property protection in Poland is rather weak, especially in comparison with other developed countries. Additionally the assessment deteriorates from year to year which suggests that Poland's authorities do not give enough attention to this issue. Poland's legal order dedicated to intellectual property protection meets all modern requirements and Poland is a signatory to all main international agreements, including TRIPS agreement. Unfortunately the enforcement of intellectual property protection in Poland is still insufficient and deviates from the standards of developed countries. In particular copyright protection is weak and enforcement of owner's rights is really difficult and online digital piracy especially among young users is huge (Tomczyk, 2018). Without effective intellectual property protection entrepreneurs and investors will not be willing to invest their knowledge, skills, efforts, time and funds into creation of innovative works. Nowadays competitive advantage of firms, branches and economies depends on their ability to create new technologies and products. Therefore the effective protection of intangibles rights is a necessary incentive which guarantees profits for innovators. Only in a conducive environment that ensures and respects such protection, entrepreneurs, scientist and authors are willing to invest in creative works which based on novelty. Such investments are usually long-term, expensive, and with high investment risk. Proper intellectual property protection is a prerequisite for the increase of international competitiveness and entrepreneurship, economic and social growth and development, employment growth, improving life standards, and an efficient exploitation of economic resources.

#### LITERATURE:

1. Bochańczyk-Kupka D. (2015). The controversy about appropriate level of intellectual property rights protection. *The Macrotheme Review* 4(8), Special Issue IV, p. 75-83.
2. Global Innovation Policy Center. 2018. *Create, US Chamber International IP Index*. Sixth edition, US Chamber of Commerce.
3. *International Property Right Index 2018. Full Report*. Retrieved 20.11.2018 from <https://www.internationalpropertyrightsindex.org/full-report>.
4. Tomczyk Ł. 2018. *Protection of Intellectual Property Rights in Poland from the perspective of Polish youth*. Conference: e-Society 2018, International Association for the Development of the Information Society at: Lisbon, Portugal, Volume: 16, p.335-340.
5. Schwab K. (2018). *Global Competitiveness Report 2018*. World Economic Forum, Geneva.
6. United Nations Economic Commission for Europe. 2011. *Intellectual Property Commercialization. Policy Options and Practical Instruments*. New York.
7. World Intellectual Property Organization. 2018. *What is Intellectual Property*. Retrieved 18.11.2018 from <http://www.wipo.int>.



## **CUSTOMERS' REACTION TO UNETHICAL COMPANIES' BEHAVIOUR – COMPARING WEST VERSUS EAST EUROPE**

**Valeryia Chouhun**

*FEP, University of Porto, Portugal  
valeryia.chouhun@gmail.com*

**Raquel Meneses**

*FEP, University of Porto, Portugal  
raquelm@fep.up.pt*

**Humberto Ribeiro**

*GOVCOPP, ESTGA, University of Aveiro, Portugal  
hnr@ua.pt*

### **ABSTRACT**

*This research examines the customers' reaction to unethical behaviour of companies. The study focuses on the differences between Eastern versus Western European customers. More specifically, two main hypotheses were formulated: (1) The self-perception of customers about ethics (concerning ethical, ecological and social issues) is different in Eastern and Western Europe; (2) The mean of customers' reaction on unethical behaviour of the companies is different in Eastern and Western Europe. A quantitative study was conducted through hypothesis tests. The empirical study involved a sample of two-hundred-and-two responses from customers from different countries from Europe and Post-Soviet era countries as well. The findings suggest there are differences between Eastern and Western European customers as their reactions on unethical behaviour differ. Moreover, the results gave support to the main hypotheses outlined, i.e. that the mean of customer's reaction on unethical behaviour and their self-perceptions are different in East and West Europe. Customers from West Europe rate themselves better and are more prone to react against unethical companies' behaviour. Furthermore, Western consumers are more keen and likely to disclose and diffuse unethical corporate procedures.*

**Keywords:** *Ethics, Culture, Consumer Behaviour, Corporate Practices and Management, West Europe, East Europe*

### **1. INTRODUCTION**

Nowadays, it is very important for all the companies in the world to understand which actions of the companies are ethical or unethical for the customers. The problem is that there is a lot of information concerning ethical/unethical behaviour, brand image and company's reputation, but there is not so much about differences in customer's attitude to the unethical behaviour depending on nationality. With this research we should understand how people react on unethical behaviour depending on nationality. The customers differ depending on the country, religion and culture. Customer's attitudes to the companies are also different regarding ethical/unethical behaviour. Accordingly, the main questions outlined for of this research are:

1. How people consider themselves in terms of ethical conscientiousness in East and West Europe?
2. Is there difference between customer's reaction depending being from East or West Europe?

### **2. CONSUMER AND BUSINESS ETHICS**

Models of business ethics progressively identify that ethical behaviour differs cross-culturally and how culture impacts on the ethical reasoning process that claims individuals' ethical

activities (Thorne & Saunders, 2002). Media intelligences of unethical behaviour of the brands are widespread in the market. They can range from fast moving products and food to automobiles and air crafts. In the short term, these episodes of harmful publicity can be busting and consequence in direct losses of profit and revenue. In the long term, these episodes can damage brands, leading to decline in the market and brand equity (Steinman & Wolfrom, 2012). According to Sherwin (1983, p.183) "ethics is generally referred to as the set of moral principles or values that guide behaviour". However, what founds ethical and unethical behaviour can vary depending on the framework of moral principles used as the basics for conclusion. Ethics is the common moral values and orders that was accepted in concrete group or society. So different countries, with different cultural must have different notions of ethics. Thus, ethics has a direct impact on company`s image and goodwill. In company`s practice ethical questions (scandals, charges and failures) most often connected with marketing (Roering & Enis, 1981) These problems and ambiguous activities impact on company`s image and reputation and therefore on company`s performance. Different cultural contexts fetch to different ways of identifying the world and cultural differences impact on individuals` ethical reasoning (MacDonald, 2000). Customers from various cultures differ in their sensibility to ethical situations (Cohen et al. 1992), awareness, ethical principles, and ethical behaviours (Izraeli, 1998). The comprehension of how individuals` ethical reasoning can differ according to cultural context is important if international companies wish to embed ethical values through the company (Desai & Rittenburg, 1997). Ethical behaviour has a big influence on the improvement and maintenance of the producer-customer relationship (Roman, 2003). Ethical consumer behaviour divided into two groups in scientific literature: "consumer ethics" and "ethical consumerism" (Chatzidakis et al. 2004). Consumer ethics is "the moral principles and standards that guide behaviour of individuals or groups as they obtain, use and dispose of goods and services" (Muncy & Vitell 1992, p. 298). Ethical consumerism includes interest for the business practices, environment, and social honesty and repels the customer social conscience (Chatzidakis et al. 2004). Ethical consumerism is determined as progression of "green" or environmental consumerism. It also contains social and ethical sides of consuming like human rights and fair trade. It based on the performance of the "socially conscious" or "ecologically conscious" customer (Webster, 1975; Robertson & Ross, 1995). It is clear the connection between definitions "ethical" and "social responsible" according to consumer behaviour. According to Lindenmeier et al. (2012), unethical corporate behaviour can be a result in consumer outrage and that consumer outrage presents a complex of emotions from a process understanding perspective. Unethical corporate behaviour impacts on customer outrage via special mechanism, that has emotional basis that presented by effective-response construction and cognitive foundation that means dis-verification of moral norms. Consumer outrage presents a key activator of customer boycotting behaviour from a prognostic understanding perspective. This result may be because consumers regard boycotting as an opportunity to release their anger and to restore fairness and justice (Lindenmeier et al.2012). To understand more deeply the ethical consumerism Farhangmehr et al. (2011) divided its issues on three categories according its nature: environmental, ethical and social issues. This is connected with the liberality of human rights abuses, environmental pollution, activities that break with cultural and religious norms, the labour usage are important kinds of business practices that instigate outrage. We can divide negative consumer reactions in two groups (Grappi et al.2013):

- Negative word-of-mouth (that include three forms of negative word of mouth: saying negative things, recommending against purchasing, and discrediting the company). Negative word of mouth is the spread of dislike, disfavour, or disregard regarding wrong actions by corporations. The aim of negative word of mouth is to express abuse out of anger and punish the guilty corporation.

- Protest, being protest behaviours are activities taken against corporate unethical behaviour with the aim of getting companies to stop committing harmful acts (Grappi et al. 2013). Negative word of mouth and protest behaviours are absolutely different from positive behaviours, but they also differ in their social consequences (Grappi et al. 2013). It is very individual activity of each customer to decide to buy company's product or not and negative word of mouth can be shown as involve a kind of emotional sharing with others (Rime, 2009; Wetzler et al., 2007), and also involves communication and public influence as well. Protest behaviours present social activities as a buyers-to-company impact and can be a sign of wrath, vengeance, or other negative kinds of behaviour (Kozinets & Handelman, 2004; Ward & Ostrom, 2006). Also people can organize groups and attract third-party intermediaries that they can support (for example - Greenpeace) (Grappi et al. 2013).

Companies must monitor customer assessments of the firm's behaviour (Huber et al. 2010), and to avoid negative impacts on company image, reputation, and sales, firms must quickly identify and restore damages caused by its behaviours. Company must show their compassion and attention to the problem.

### **3. METHODOLOGY**

In order to better test the research questions we decided to use quantitative research that allows us to collect the primary data from survey and factor analysis to analyse and summarise this data. The uniqueness of this research is that survey was presented in different languages (English, Portuguese and Russian). This survey started with demographic questions, like gender, age, education and nationality. There are a lot of studies regarding gender differences (Brunel and Nelson (2000), Haidt (2003), Lindenmeier et al. (2012), confirming that men and women differ in their ethical behaviour. Regarding age and formal education points there are a lot of studies that confirm that young people have other reactions on different situations than older people (Ruegger and King (1992), Burnett & Karson, 1987; Posner & Schmidt, 1984). The study of Serwinek (1992) shows that people with high-school education and college education has small difference, but the difference between basic school and high-school education in ethical attitudes has significant level. The impact of nationality, however, is not well-known. In our case, nationality is the most important factor that can have an effect on the research results. There is a huge quantity of studies that show that people from different parts of the world are differing from each other. According to Babakus et al. (2004) customer ethics vary from country to country due to historical patterns of conduct and socialization to current norms of conduct. Another study by Polonsky et al., (2001) shows the difference between students from Northern and Southern Europe. Regarding Grazuleviciute-Vileniske and Urbonas (2014) study, countries that are experiencing the post-Soviet transformation have specific factors that can affect the process of urban regeneration in different ways. Also according to Berend (2007) and Vaitkuviene (2010) the main characteristic of the post-Soviet countries' transformation is "the sharp collision" of traditional values and Soviet Union values with social behaviour requirements such as entrepreneurship, risk taking, efficiency and pluralism. As Kersztely and Scott (2012) note "The social dimension has been slow to arrive in the social dimension Post-Socialistic countries (p.1127). According to Smolentseva (2012) "After the fall of USSR the countries of the region have to face a number of challenges: economic collapse, political reforms, economic transformations as well as globalization challenges" (p.8).

### **4. SURVEY DESIGN**

We asked our respondents to characterize themselves from ethical, ecological and social point of view, with self-rating questions, ranked using a 7-point Likert scale (where 1 = absolutely agree, 4 = undecided and 7 = absolutely disagree):

- Characterize yourself. I am ethical person
- Characterize yourself. I am eco-friendly person
- Characterize yourself. I am concerned about human rights violation

This helped the research to understand how people think about themselves and how they compare with their answers for situational questions. About questions simulating unethical situations, Farhangmehr et al. (2011) present three kinds of ethical consumerism according to its nature: ecological, ethical and social. This classification was adapted to research by simulation of unethical situations in survey questions. The most important and often relevant ethical issues were grouped into five main groups that present each different kind of ethical questions:

1. Animal rights (environmental)
2. Environment (environmental)
3. Human rights (ethical)
4. Labour practices (ethical)
5. Harmful productions (social)

Afterwards, the questionnaire was formed regarding to these groups. The questions were adapted to the real situations in the market world. This helped to understand what customer thought regarding different unethical situations and how they rate their reaction on specific situations. The survey included four possible answers regarding active factors:

- Stop to buy
- Tell to your friends stopped to buy
- Share in social networks
- Boycott

Conversely, the survey included three possible answers regarding passive factors:

- I am not interesting in that
- Don't react
- Decision depends from the price

The specific questions were made as follows. Environmental questions regarding oil pollution: One well-known oil company leaked oil into the Mexican Gulf. How would you react on that?

Next two samples presented problems regarding animal rights issues.

Questions about using fur of rare animals in textile companies: Imagine that one of well-known textile company uses in their production the fur of rare animals. How would you react on that?

Questions about animal testing in cosmetic company: One cosmetic company produced a new shampoo. But mass-media inform that they still continue testing on animals. How would you react on that?

Questions about using GMI (Genetically Modified Ingredients) components in food production: one well-known food company uses in GMI components in food production. How would you react on that?

Questions about female rights in Arabian countries: A furniture and home accessories company made a special catalogue for Arabian countries without women pictures. How would you react on that?

The last two questions simulated situations regarding labour rights.

Questions about the situation at the shoe factory in Bangladesh and bad working conditions: A shoemaker moved their factories to Bangladesh, where employees work in the sweatshops with bad working conditions and they also receive a very small salary. How would you react on that?

Questions about a situation regarding cancellation of medical treatment for employees: One well-known worldwide hotel chain stopped providing medical treatment for their workers. How would you react on that?

Finally, it is important to highlight that the survey was designed and posted in social networks such as Facebook and Odnoklassniki (Russian social network).

## 5. HYPOTHESIS TESTING

According to Malhotra and Birks (2007) "hypothesis testing is one of the fundamental building blocks of quantitative data analysis. It provides insights into the data, guide subsequent analyses and aid the interpretation of results" (p. 502). Table 1 presents the hypotheses tested.

*Table 1: Secondary hypotheses*

Null hypothesis	Alternative hypothesis
H1.0 – On average ethics approach is equal in East and west Europe concerning ethical issues H1.1.0 – On average self-rating perception about ethics is equal in East and West Europe. H1.2.0 – On average the reaction to unethical companies' behaviour concerning ethics is equal in East and West Europe.	H1.1 – On average ethics approach is different in East and west Europe concerning ethical issues H1.1.1 – On average self-rating perception about ethics is different in East and West Europe. H1.2.1 – On average the reaction to unethical companies' behaviour concerning ethics is different in East and West Europe.
H1.0 – On average ethics approach is equal in East and west Europe concerning environmental issues H1.1.0 – On average self-rating perception about ecology is equal in East and West Europe. H1.2.0 – On average the reaction to unethical companies' behaviour concerning ecology is equal in East and West Europe.	H1.1 – On average ethics approach is different in East and west Europe concerning environmental issues H1.1.1 – On average self-rating perception about ecology is different in East and West Europe. H1.2.1 – On average the reaction to unethical companies' behaviour concerning ecology is different in East and West Europe.
H1.0 – On average ethics approach is equal in East and west Europe concerning social issues H1.1.0 – On average self-rating perception about human rights is equal in East and West Europe.  H1.2.0 – On average the reaction to unethical companies' behaviour concerning human rights is equal in East and West Europe.	H1.0 – On average ethics approach is different in East and west Europe concerning social issues H1.1.0 – On average self-rating perception about human rights is different in East and West Europe.  H1.2.0 – On average the reaction to unethical companies' behaviour concerning human rights is different in East and West Europe.

The hypotheses were tested using simple statistical procedures. T test is a statistical examination of two population means. A two-sample t-test examines whether two samples are different and is commonly used when the variances of two normal distributions are unknown and when an experiment uses a small sample size. In our research, a t-test was used to compare the average ethics approach of the East Europeans to the average ethics approach of West Europeans. The survey was completed by people from different countries of Europe and Post-Soviet countries and translated to English.

Two-hundred-and-five responses were received, but we have to exclude three responses from Turkish and one response from Mauritian, because Turkey and Mauritania are situated out of our research area. So, we have two-hundred-and-one valid responses (Table 2):

*Table 2: National Respondents Distribution*

<b>East Europe</b>	<b>West Europe</b>
Armenian 1	British 1
Belarusian 54	Dutch 2
Kazakhstan 1	French 3
Moldavian 7	German 2
Russian 34	Italian 1
Ukrainian 3	Latvian 3
	Polish 5
	Portuguese 80
	Spanish 3

Both subsamples are larger than 30 observations, so we can use Central Limit Theorem, assuming normal distribution. We reversed the scores of some scale items. Each of seven situational questions has three possible reactions as:

- I am not interesting in that
- I don't react
- Decision depends from the price

Which were constructed in the opposite direction. The impact of unethical behaviour of the companies on customer's attitude was evaluated through an Exploratory Factor Analysis (EFA) on the correlation matrix, with the extraction of factors by the method of principal components analysis and the rotated component matrix by the method of Varimax rotation with Kaiser Normalization. In order to evaluate the validity of the EFA, the Kaiser-Meyer-Olkin (KMO) coefficient was applied as well as the Bartlett's Test of Sphericity. The main aim of the analysis was to reduce the 49 factors of the survey, so it was made an EFA to each one of the 7 variables (Anti-Pollution, Anti-Fur, Anti-Animal testing, Anti-GMI components, Anti-Women rights violation, Anti- Sweatshops, Anti-Labour rights violation).

*Table following on the next page*

*Table 3: Scale construction*

Original question	KMO	Sig	Scale
M1 – One well-known oil company leaked oil into the Mexican gulf. How will you react on it?	0.721	0.000	Active Anti-Pollution
		0.000	Passive Anti-Pollution
M2 – One well-known textile company uses in their production the fur of rare animal. How will you react on it?	0.844	0.000	Anti-Fur
M3 – One cosmetic company produces a shampoo. But mass-media informs that they still testing on animals. How will you react on it?	0.793	0.000	Active Anti-Animal Testing
		0.000	Passive Anti-Animal Testing
M4 – One well-known food company uses GMI components in food production. How will you react on it?	0.789	0.000	Active Anti-GMI components
		0.000	Passive Anti-GMI components
M5 – Furniture and home accessories company made a special catalogue for Arabian countries without women pictures. How will you react on it?	0.736	0.000	Active Anti-Woman rights violation
		0.000	Passive Anti-Woman rights violation
M6 – Shoe company moved their factories to Bangladesh, where employees work in sweatshops with bad working conditions and they also receive very small salary. How will you react on it?	0.803	0.000	Active Anti-Sweatshops
		0.000	Passive Anti-Sweatshops
M7 – One well known all over the world hotel chain stops to provide medical treatment for their workers. How will you react on it?	0.752	0.000	Active Anti-Labour rights violation
		0.000	Passive Anti-Labour rights violation

As we can see from the table 3, all the KMO coefficients have mean above 0.6 and significance is 0.000 that implies factor analysis is appropriate.

### 5.1. Scale reliability

With this process, 13 scales of consumers' reaction to unethical behaviour were constructed (vid. Table 4).

*Table following on the next page*

*Table 4: Twitter definitions*

New Variable	Twitter definition
Active Anti-Pollution	It means that the respondents involved in process of evaluating unethical situations and they are ready to act (stop to buy products, tell to their friends, share in social networks and boycott) regarding the oil pollution in Mexican Gulf.
Passive Anti-Pollution	These factors mean that people are not interested or may be interested in Mexican Gulf pollution but they are not ready to make any actions.
Anti-Fur	People have strong reaction on situation concerned with fur. It means that they are involved in rare animals protection.
Active Anti-Animal Testing	These factors mean that people are involved and ready to act in animal protection.
Passive Anti-Animal Testing	These factors mean that people are not interested or may be interested in animal testing issues, but are not ready to act in animal protection.
Active Anti-GMI components	These factors mean that people are interested in eco-friendly food production and they are ready to act if they know that companies use GMI components that could harmful human health.
Passive Anti-GMI components	These factors suggest that people are not interested or may be interested in eco-friendly food, but they are not ready to act.
Active Anti-Women rights violation	These factors mean that people are interested in protection of women rights in Arabian countries, and they are ready to take action in protection of women rights.
Passive Anti-Women rights violation	These factors mean that people are not interested or may be interested in protection of women rights but they are not ready to act.
Active Anti-Sweatshops	These factors mean that people are ready to take action in labour rights protection
Passive Anti-Sweatshops	These factors mean that people are not interested or are may be interested but not ready to take action in labour action protection.

According to Pallant (2005), Cronbach's alpha coefficient is one of the most commonly used indicators of internal consistency. Cronbach alpha coefficient of a scale should be above 0.7.

*Table 5: Cronbach's alpha coefficients*

Variables	Cronbach's alpha coefficient	
	Active factors	Passive factors
Anti-Pollution	0.866	0.798
Anti-Fur	0.883	-
Anti-Animal testing	0.890	-
Anti-GMI components	0.881	0.751
Anti-Women rights violation	0.892	0.678
Anti- Sweatshops	0.881	0.740
Anti-Labour rights violation	0.894	0.760

Almost each coefficient is more than 0.7. Just only one Cronbach's alpha coefficient of Women rights violation (passive factors) is 0.678, that little bit less than optimal value.



Regarding animal variable, we used just active group of factors because all passive factors scales have alphas very small.

## 5.2. T-test and Levene statistics results

First we need to check the null hypotheses regarding self-rating.

Null hypothesis H1.1.0 – On average self-rating perception about ethics is equal in East and West Europe
Null hypothesis H2.1.0 – On average self-rating perception about ecology is equal in East and West Europe
Null hypothesis H3.1.0 – On average self-rating perception about human rights is equal in East and West Europe

An independent samples t-test was conducted to compare the self-esteem scores for East Europe (1 region) and West Europe (0 region).

Table 6: T-test and Levene statistics

Self- rating		Levene Test	T Test
		Sig	Sig (bilateral)
Ethics	Equal Variance Assumed	0,000	0.000
	Equal Variance not assumed		0.000
Ecology	Equal Variance Assumed	0,133	0.003
	Equal Variance not assumed		0.003
Human- rights	Equal Variance Assumed	0,008	0.000
	Equal Variance not assumed		0.000

In all cases, the significance of T-test is 0.000, it means that there is statistically significant difference between East European and West European regions. So, linking this result (Table 10) to descriptive analysis (Table 9), we can say that people from Western Europe feel themselves more ethical, ecological, and human rights violation concerned than people from East Europe rate themselves. The following step is checking null hypotheses regarding reaction to unethical behaviour of the companies.

Null hypothesis H2.2.0 – On average the reaction to unethical companies` behaviour concerning ecology is equal in East and West Europe
--

Table 7: T-test and Levene statistics

Anti-Pollution		Levene Test	T Test
		Sig	Sig (bilateral)
Active	Equal Variance Assumed	0,547	0.777
	Equal Variance not assumed		0.777
Passive	Equal Variance Assumed	0,009	0.000
	Equal Variance not assumed		0.000

According to Table for Active Anti-Pollution the significance of T-test is 0.777, it means that there is no statistically significant difference between East European and West European regions. For Passive Anti-Pollution t-test is 0.000, it means that there is statistically significant difference between East European and West European regions. Linking this result (Table 16) to descriptive analysis (Table 15). We can claim that people from West European countries are more committed with Passive Anti-Pollution actions than East Europeans.

Null hypothesis H2.2.0 – On average the reaction to unethical companies` behaviour concerning ecology is equal in East and West Europe

Table 8: T-test and Levene statistics

		Levene Test	T Test
		Sig	Sig (bilateral)
Anti-Fur	Equal Variance Assumed	0.920	0.000
	Equal Variance not assumed		0.000

As we can see from Table 18 the significance of T-test is 0.000, it means that there is statistically significant difference between East European and West European regions and linking this result to descriptive analysis (Table 17), we can affirm that West Europeans are more committed with Anti-Fur actions than East Europeans.

Null hypothesis H2.2.0 – On average the reaction to unethical companies` behaviour concerning ecology is equal in East and West Europe

Table 9: T-test and Levene statistics

		Levene Test	T Test
		Sig	Sig (bilateral)
Anti-Animal Testing			
Active	Equal Variance Assumed	0,070	0.167
	Equal Variance not assumed		0.167
Passive	Equal Variance Assumed	0,615	0.000
	Equal Variance not assumed		0.000

Regarding table 20, for Active Anti-Animal the significance of T-test is 0.167, it means that there is no statistically significant difference between East European and West European regions. For Passive Anti-Animal the significance of T-test is 0.000, it means that there is statistically significant difference between East European and West European regions. So, linking this result (Table 20) to descriptive analysis (Table 19), we can say that West Europeans are more committed Active and Passive Anti-Animal testing activities than East Europeans.

Null hypothesis H3.2.0 – On average the reaction to unethical companies` behaviour concerning human rights is equal in East and West Europe

Table 10: T-test and Levene statistics

		Levene Test	T Test
		Sig	Sig (bilateral)
Anti-GMI components			
Active	Equal Variance Assumed	0,234	0.064
	Equal Variance not assumed		0.064
Passive	Equal Variance Assumed	0,639	0.158
	Equal Variance not assumed		0.159

According to Table 22 for active factors the significance of T-test is 0.064, it means that there is no statistically significant difference between East European and West European regions. For passive factors the significance of T-test is 0.158, it suggests that there is no statistically significant difference between East European and West European regions.

Null hypothesis H3.2.0 – On average the reaction to unethical companies` behaviour concerning human rights is equal in East and West Europe

Table 11: T-test and Levene statistics

Anti-Women rights violation		Levene Test	T Test
		Sig	Sig (bilateral)
Active	Equal Variance Assumed	0,009	0.146
	Equal Variance not assumed		0.147
Passive	Equal Variance Assumed	0,720	0.000
	Equal Variance not assumed		0.000

As we can see from Table 11, for Active Anti-Women rights violation the significance of T-test is 0.147, it means that there is no statistically significant difference between East European and West European regions. For Passive Anti-Women rights violation the significance of T-test is 0.000, it suggests that there is statistically significant difference between East European and West European regions. Linking this result to descriptive analysis (Table 23), we can affirm that West Europeans are more ethical regarding Passive Anti-Women rights violation than East Europeans.

Null hypothesis H1.2.0 – On average the reaction to unethical companies` behaviour concerning ethicality is equal in East and West Europe

Table 12: T-test and Levene statistics

Anti-Swetshops		Levene Test	T Test
		Sig	Sig (bilateral)
Active	Equal Variance Assumed	0,331	0.000
	Equal Variance not assumed		0.000
Passive	Equal Variance Assumed	0,655	0.000
	Equal Variance not assumed		0.000

Regarding Passive Anti-Sweatshops the significance of T-test is 0.000, it suggests that there is statistically significant difference between East European and West European regions. Linking this result to descriptive analysis (Table 12), we can claim that West Europeans are more ethical regarding Active and Passive Anti-Sweatshops activities than East Europeans.

Null hypothesis H1.2.0 – On average the reaction to unethical companies` behaviour concerning ethicality is equal in East and West Europe

Table 13: T-test and Levene statistics

Anti-Labour Rights Violation		Levene Test	T Test
		Sig	Sig (bilateral)
Active	Equal Variance Assumed	0,793	0.016
	Equal Variance not assumed		0.016
Passive	Equal Variance Assumed	0,217	0.000
	Equal Variance not assumed		0.000

As we can see from Table 13, for Active Anti-Labour rights violation the significance of T-test is 0.016, it means that there is statistically significant difference between East European and

West European regions. For Passive Anti-Labour rights violation, the significance of T-test is 0.000, it suggests that there is statistically significant difference between East European and West European regions. Linking these results to the descriptive analysis made, we can affirm that people from West Europe are more ethical regarding Active and Passive Anti-Labour rights violation actions than people from East Europe.

To summarize the results the following table was made:

*Table 14: Summary of results*

Hypothesis	Hypotheses rejected	Results
H1.0 – The mean of customer’s reaction on unethical behaviour of the companies regarding ethics is equal in East and West Europe	1 - Self-rating (ethical issues)	1 - West European feel themselves mores ethical than East Europeans feel themselves.
	2 - Active Anti-Sweatshops	2 – People from West Europe are more ethical regarding Active Anti-Sweatshops activities than people from East Europe
	3 – Passive Anti-Sweatshops	3 – People from West Europe are more ethical regarding Passive Anti-Sweatshops activities than people from East Europe
	4 – Active Anti-Labour rights violation	4 – West Europeans are more ethical regarding Active Anti-Labour rights violation activities than East Europeans
	5 – Passive Anti-Labour rights violation	5 – West Europeans are more ethical regarding Passive Anti-Labour rights violation activities than East Europeans
H2.0 – The mean of customer’s reaction on unethical behaviour of the companies regarding ecology is equal in East and West Europe	6 – Self-rating (ecological issues)	- West European feel themselves mores ecological than East Europeans feel themselves.
	7 – Active Anti-Pollution	7 – People from West Europe are more ethical regarding Active Anti-Pollution action than people from East Europe

## 6. CONCLUSION

Regarding ethical issues we can say that West Europeans feel themselves more ethical than East Europeans feel themselves. Moreover people from West Europe are more ethical regarding Active and Passive Anti-Sweatshops activities than people from East Europe. The results of analysing Anti-Labour rights violation shows that West Europeans are more ethical regarding Active and Passive factors than East Europeans. Concerning to ecological issues we can claim that West Europeans feel themselves more ethical regarding ecological issues than East Europeans feel themselves. But regarding Active Anti-Pollution actions people from West Europe and East Europe are similar in their attitude to this problem. West Europeans are more ethical regarding Passive Anti-Pollution actions than East Europeans. People from West Europe are more ethical regarding Active Anti-Fur activities than people from East Europe.

But regarding Active Anti-Animal testing the position of East and West Europeans are similar. Regarding social issues, we can affirm that West Europeans feel themselves more ethical regarding social issues than people from East Europe feel themselves. But according to Active and Passive Anti-GMI components and Active Anti-Women rights violation activities people from East and West Europe are similar in their attitude. West Europeans are more ethical to Passive Anti-GMI components actions and Passive Anti-Women rights violation activities than East Europeans. This research can give recommendations for companies and managers in analysing market reaction in East and West Europe, it can help with deep understanding of the customers` attitude on unethical behaviour of the companies. Analysing results of our research we can suggest answers to the main research questions:

1. How people react on unethical behaviour of the companies?

So, as was found, people react on unethical behaviour of the companies and there are many differences in their reactions on unethical behaviour of the companies.

2. Is there difference between customer`s reaction depending on East or West Europe?

We found that customers from East and West European countries are different in many situations that were analysed:

- Self-rating regarding ethical issues
- Self-rating regarding ecological issues
- Self-rating regarding social issues
- Anti-Sweatshops (active and passive factors)
- Anti-Labour rights violation (active and passive factors)
- Anti-Pollution (passive factors)
- Anti-Fur
- Anti-Animal testing (passive factors)
- Anti-GMI components (passive factors)
- Anti- Women rights violation (passive factors)
- But some situations present us similarity in viewpoints of East and West Europeans:
- Anti-Pollution (active factors)
- Anti-Animal testing (active factors)
- Anti-GMI components (active and passive factors)
- Anti- Women rights violation (active factors)

Therefore, we can claim that differences exist and it is varying depending on unethical situations. But in common we can claim that East and West Europeans are different according to ethical issues (Self-rating, Active and Passive Anti-Sweatshops, Active and Passive Anti-Labour rights violation), ecological issues (Self-rating, Passive Anti-Pollution, Anti-Fur and Passive Anti-Animal testing) and social issues (Self-rating and Passive Anti-Women rights violation). As a result of the research, some new themes are emerged from the analysis. It is important for companies to measure the real impact of unethical actions on brand reputation, because it has direct negative influence on brand image of the company. Our questionnaire tried to present real situations; however we are not sure if respondents feel it in the same way, at the same time people tend to be politically correct. We tested situations that happening far from national/regional/local realities. Maybe people do not feel connected with them neither understands completely the situation. In future research it is important to design the questionnaire for different nationalities with questions that will be focused on one separate country and will present the situations that reflect possible local incidents. We really believe that this study has a contribution in understanding how people from different societies react on unethical companies` behaviour, and this is very important as it have a huge impact on brand image, firms` reputation and consequent performance.

## LITERATURE:

1. Berend I.T. (2007). Social shock in transforming Central and Eastern Europe. *Communism Post-Commun.* 40 (3), pp. 269-280.
2. Brunel F.F., Nelson M.R. (2000). Explaining Gendered Responses to “help-self” and “help-others” Charity and Appeals: The Mediating Role of World-views. *J Advert*, 29, pp. 15-27.
3. Burnett J.H., Karson M.J. (1987). Personal Values and Business Decisions. *Journal of Business Ethics* 6, pp. 371-82.
4. Chatzidakis A., Hibbert S., Mitussis D., Smith A. (2004). Virtue in Consumption? *Journal of Marketing Management*, 20 (5/6), pp. 527-544.
5. Cohen J., Pant L., Sharp D. (1992). Cultural and Socio-economic Constraints on International Codes of Ethics: Lessons from Accounting. *Journal of Business Ethics*, 11, pp. 687–700.
6. Desai A., Rittenburg T. (1997). Global Ethics: An Integrative Framework for MNEs. *Journal of Business Ethics*, 16, pp. 791–800.
7. Farhangmehr M., Malheiro A., Soares A. (2011). Ethical Consumer Behaviour: Can Critical Incidents Make a Difference? *Academic Public Administration Studies Archive-APAS*. (No. 331).
8. Grappi S., Romani S., Bagozzi R.P. (2013). Consumer response to corporate irresponsible behavior: Moral emotions and virtues. *Journal of Business Research*, 66 (10), pp. 1814–1821.
9. Grazuleviciute-Vileniske, I., Urbonas, V. (2014). Urban regeneration in the context of post-Soviet transformation: Lithuanian experience. *Journal of Cultural Heritage*, 15 (6), pp. 637-643.
10. Haidt J. (2003). The Moral Emotions. In: David, J.R., Scherer, K.R., Goldsmith, H.H., editors. *Handbook of affective sciences*. Oxford: Oxford University Press, pp. 852-870.
11. Huber F., Vollhardt K., Matthes J., Vogel, J. (2010). Brand misconduct: consequences on consumer –brand relationships. *Journal of Business Research*, 63 (11), pp. 1113-1120.
12. Izraeli D. (1988). Ethical Beliefs and Behaviour Among Managers: A Cross-cultural Perspective. *Journal of Business Ethics*, 7, pp. 263–271.
13. Kersztely K., Scott J.W. (2012). Urban regeneration in the post-social context: Budapest and the search for a social dimension. *Eur. Plan. Stud.*, 20 (7), pp.1111-1134.
14. Kozinets R.V., Handelman J.M. (2004). Adversaries of consumption: Consumer movements, activism, and ideology. *Journal of Consumer Research*, 31, pp. 691–704.
15. Lindenmeier J., Schleer C., Pricl D. (2012). Consumer outrage: Emotional reactions to unethical corporate behaviour. *Journal of Business Research*, 65 (9), pp. 1364–1373.
16. Macdonald G. (2000). Cross-cultural Methodological Issues in Ethical Research. *Journal of Business Ethics* 27 (1/2), pp. 89–104.
17. Malhotra N.K., Birks D.F. (2007). *Marketing Research. An Applied Approach*. Third Edition. Pearson Inc.
18. Muncy J., Vitell S. (1992). Consumer ethics: an investigation of the ethical beliefs of the final consumer. *Journal of Business Research*, 24 (4), pp. 297-311.
19. Pallant J. (2005). *SPSS Survival Manual. A Step by Step Guide to Data Analysis Using SPSS for Windows (version 12)*. Allen & Unwin.
20. Polonsky M.J., Brito P.Q., Pinto J., Higgs-Kleyn N. (2001). Consumer Ethics in the European Union: a comparison of northern and southern views. *Journal of Business Ethics*, 31, pp. 117-30.
21. Posner B. Z., Schmidt W. (1984). Values and the American Manager: An Update. *California Management Review*, 26 (3), pp. 202-16.
22. Rime B. (2009). Emotion elicits the social sharing of emotions: Theory and empirical review. *Emotion Review*, 1 (1), pp. 60–85.

23. Robertson D., Ross W. (1995). Decision-Making Processes on Ethical Issue. *Business Ethics Quarterly* 5 (2), pp. 213–241.
24. Roering K., Enis B. (1981). Marketing ethics: a review with implications for managers, educators and researchers. *Review of Marketing*.
25. Roman S. (2003). The Impact of Ethical Sales Behaviour on Customer Satisfaction, Trust and Loyalty to the Company: An Empirical Study in the Financial Services Industry. *Journal of Marketing Management*, 19 (9-10), pp. 915-939.
26. Ruegger D., King, E.W. (1992). A Study of the Effect of Age and Gender upon Student Business Ethics. *Journal of Business Ethics*, 11, pp. 179-86.
27. Serwinek P.J. (1992). Demographic and Related Differences in Ethical Views among Small Businesses. *Journal of Business Ethics*. 11, pp. 555-566 .
28. Sherwin D.S. (1983). The ethical roots of the business system. *Harvard Business Review*, 61 (November-December), pp. 183-92.
29. Smolentseva, A. (2012). Access to Higher Education in the Post-Soviet States: Between Soviet Legacy and Global Challenges. In Paper commissioned and presented at Salzburg Global Seminar, Session, 495, pp. 2-7.
30. Steinman R. B., Wolfrom B.T. (2012). The Effect of Brands' Unethical Actions on Consumers' Attitudes in the Fast Moving Consumer Goods Domain-Business Management Dynamics. 2 (3), pp.32-39.
31. Thorne L., Saunders S.B. (2002). The Socio-Cultural Embeddedness of Individuals' Ethical Reasoning in Organizations (Cross-Cultural Ethics). *Journal of Business Ethics*, 35: pp. 1-14.
32. Vaitkuvienė A. (2010). Processes of patrimonialization in Soviet and post-Soviet Lithuania (Summary doctoral dissertation). Vilnius University, Vilnius.
33. Ward J.C., Ostrom A.L. (2006). Complaining to the masses: The role of protest framing in customer-created complaint web sites. *Journal of Consumer Research*, 23, pp. 220–230.
34. Webster F. (1975). Determining the Characteristics of the Socially Conscious Consumer. *Journal of Consumer Research*, 2 (3), pp. 188-196.
35. Wetzer I. M., Zeelenberg M., Pieters R. (2007). Never eat in that restaurant, I did!: Exploring why people engage in negative word-of-mouth communication. *Psychology and Marketing*, 24 (8), pp. 661–680.

# FACTORS OF COMPETITIVENESS OF THE EUROPEAN MARKETS TO SUPPORT BUSINESS DECISION MAKING

**Laura Juznik Rotar**

*University of Novo mesto Faculty of Economics and Informatics, Novo mesto, Slovenia  
laura\_juznik@yahoo.com*

## **ABSTRACT**

*Several well established studies measure competitiveness at the country level such as the World Economic Forum and the Institute for Management Development. The former defines competitiveness as the set of institutions, policies and factors that determine the level of productivity of a country. In this paper we focus on factors of competitiveness of the European markets to support business decision making with emphasis on the strategic marketing decision of doing business internationally. In the context of managerial economic decision making the objective is usually defined as profit maximization. However, due to rapidly changing business environment managers nowadays are dealing with higher percentage of nonprogrammed decisions which are characterized by novelty, risk and uncertainty. In order to reach efficient and effective business performance, to compete, grow and be profitable when doing business internationally companies should research factors of competitiveness to allocate resources efficiently and to avoid risk and uncertainty.*

**Keywords:** *Competitiveness, Factors of competitiveness, Business decision making, Strategic decisions, Factor analysis, Measurement model*

## **1. INTRODUCTION**

Decision making lies at the heart of most important business problems. Decision making can be defined as the process of identifying and solving problems. In the problem identification phase information about the environment and company conditions is monitored to determine if performance is satisfactory and to define the potential cause of obstacles. In the solving problem phase we think of different alternatives whereas one alternative is then selected and implemented (see, for example Daft, 2007; Drucker, 2008). The question about the quality of implemented alternative can always be present especially because there is one alternative which is selected and what would have been if another alternative would have been selected cannot be compared. Another problem is that decisions are not reversible (Hollensen, 2011). Before penetrating the international markets companies are being faced with several strategic decisions, such as the target groups of customers which will buy company products, the proper way of differentiation, the identification of characteristics of products which are important in the eyes of customers, how to reach the target markets and what is the message, to choose the distribution channels (Kotler and Armstrong, 2016; Schmidt and Hollensen, 2006). Due to rapidly changing environment it is therefore important that company identifies factors of competitiveness of international markets in which is trying to do business in order to avoid risk, uncertainty, and to allocate resources effectively. The paper is structured as follows: after the brief introduction, we focus on the business decision making with emphasis on strategic marketing decision of doing business on international markets, in section 3 we present empirical research with methodological part, results and discussion, whereas section 4 concludes.

## **2. BUSINESS DECISION MAKING**

Business decisions vary in complexity and can be categorized as programmed and nonprogrammed (Adams and Juleff, 2003). Programmed decisions are repetitive and well defined and procedures exist for solving the problem. Such programmed decisions are well structured because the criteria of performance are normally clear, good information is available,



alternatives are easily specified and there is relative certainty that that the chosen alternative will be successful. On the other hand, nonprogrammed decisions are novel and poorly defined, there is no common procedure to solve the problem. Such nonprogrammed decisions are unstructured, the problem the company is faced with is completely new and there is no general prescription how to respond, alternatives are fuzzy, there is lack of information. Such nonprogrammed decisions involve strategic decisions because uncertainty is great and decisions are complex and influence the performance of the whole company. Nowadays managers are being faced with higher percentage on nonprogrammed decisions because of the rapidly changing business environment (Baye, 2010; Samuelson and Marks, 2010). Decision to choose the right market for doing business is a strategic decision which affects the performance of the whole company. Such a marketing decision making is not only a class of strategic decision making but also unstructured decision usually connected with lack of complete information, risk and uncertainty. Decision to enter onto a market has to be carefully planned, on top of that number of different factors have to be considered and which determine whether a company will be successful or not (Hollensen, 2017; Wilkinson, 2005). Before penetrating the international markets companies are being faced with several strategic decisions, such as the target groups of customers which will buy company products, the proper way of differentiation, the identification of characteristics of products which are important in the eyes of customers, how to reach the target markets and what is the message, to choose the distribution channels. In order to manage doing business internationally and in a globalized world there is a need to constantly research the dynamics of the company's environment which is diversified and non-controllable and therefore business decisions adapt according to the evolving opportunities, obstacles and constraints in a broader (external) environment of the company. It is extremely difficult to influence the external environment or the forces in the external environment of the company, which is why the company must monitor them and respond to them accordingly. The growing role and importance of the so-called global marketing is forcing companies to take into account certain global trends and factors of external environment, such as economic factors, technological factors, demographic factors, sociocultural factors, political and legal factors, factors that relate to the natural environment (see, for example IMD, 2018, Dijkstra, Annoni and Kozovska, 2011; Mankiw, 2009; Schwab, 2018). Nowadays we are faced with the vast majority of data and information and that is why companies have to be able to collect and use such data and information properly. Managers who make decisions in international environment have also to be able to answer the following questions: when they need certain information, why do they need it, what is the source of information, what sort of research activities have to be developed as well. The ability to receive the right business information at the right place, at the right time and at the reasonable price and knowledge how to use such business information is an important factor which influences the efficiency and effectiveness of business performance. Maybe the biggest problem is that managers often do not know which information they need in certain business operations and where are they able to get them. It is hard to imagine that companies would still be able to make efficient and effective business decisions without quality, on-time and reliable information. Companies have to know in detail markets in which they are doing business and market opportunities available. What is more, the environment, the product markets and the competition have to be carefully studied (Kotler, 2016). Marketing decision making is as good as good are the information available to decision makers and as many information are available. Such circumstances lower down the risk and that is why the companies have to provide good marketing information system. For decision makers it is important that relevant information are available which are gathered by systematic and quality marketing research. Marketing research make it feasible to gather usable information based on which we can make strategic decisions (Iacobucci, 2013; Feinberg, Kinnear and Taylor, 2013).

The risk of incorrect decisions can also be lowered. The advantages of systematic and quality marketing research are seen in better decision making about doing business on international markets, benchmarking of the European markets, avoiding unplanned decision making especially in companies without distinctly divided business functions which does not lead the company to the realization of the set goals and to achieving long-term and stable performance.

### 3. EMPIRICAL RESEARCH

#### 3.1. Methodological approach

Exploratory factor analysis is a general term for a class of multivariate analysis techniques whose goal is to decrease the size of a dataset and to reduce it to an actual underlying dimensionality. Following this, the large quantity of variables will be reduced to a smaller amount of previously unknown dimensions which are also referred to as factors. One such traditional approach within factor analysis is principal component factor analysis (Field, 2018). One major concern with this approach is that it tries to account for all the variance and covariance of the set of variables rather than the portion of the covariance that the variables share in common. On the other hand, confirmatory factor analysis makes a priori statements about the expected number of underlying dimensions and the nature of these. It involves testing the measurement model with latent variables which are not immediately observed (Acock, 2013). The data for our empirical research come from the Eurostat database and include many variables from economic, demographic, technological, social area for the 28 countries of the European Union and include the latest available data.

#### 3.2. Results and discussion

In this part we first present the results obtained via exploratory factor analysis. In an attempt to define underlying factors of competitiveness of the European markets to support business decision making we first proceeded with principal component factor analysis as the most traditional approach to factor analysis. Out of several variables we are interested to create factors of competitiveness of the European markets to support marketing decision making. Table 1 presents the results of factor analysis.

*Table 1: Factor analysis results (Source: authors' calculations)*

Factor	Eigenvalue	Difference	Proportion	Cumulative
Factor 1	2,795	1,512	0,559	0,559
Factor 2	1,282	0,606	0,256	0,815
Factor 3	0,676	0,487	0,135	0,951
Factor 4	0,188	0,132	0,037	0,988
Factor 5	0,056		0,011	1,000

*Table 2: Factor loadings and unique variances (Source: authors' calculations)*

Variable	Factor 1	Factor 2	Uniqueness
v10	0,914	0,293	0,077
v11	-0,924	0,055	0,142
v12	0,920	0,337	0,039
v18	-0,336	0,711	0,380
v31	-0,381	0,757	0,281

Table 1 shows the factor analysis results whereas table 2 shows factors loadings and unique variances. These results indicate that the first two factors are very strong with an eigenvalue of 2,795 and 1,282 respectively. The eigenvalue is how much of the total variance over all the variables is explained by the first and second factor.

The principal component factor analysis analyses the correlation matrix where each variable is standardized to have a variance of 1,0. We say the first factor explains 27,95% of the variance in the set of variables, whereas the second factor explains 12,82% of the variance in the set of variables. Any factor with an eigenvalue of less than 1,0 can usually be ignored. On the other hand, all the loadings of the variables of factor 1 are substantial, varying from 0,914 to 0,924, whereas the loadings of the variables of factor 2 are varying from 0,711 to 0,757. The last column in table 2 represent the unique variance of error variance. For example 38% of the variance in variable v18 is not accounted for by the factor solution. The uniqueness are sufficiently large enough that we should consider using different method for performing exploratory factor analysis which does not assume that the uniqueness are 0. Therefore, confirmatory factor analysis and factor analysis other than principal component factor analysis allows each variable to have its own unique variance and do not reflect the shared variance of all the variables included in the analysis. The latent variable is what the variables included in the analysis share, the error terms are what is unique about each variable.

Figure 1: CFA measurement model (Source: Authors)

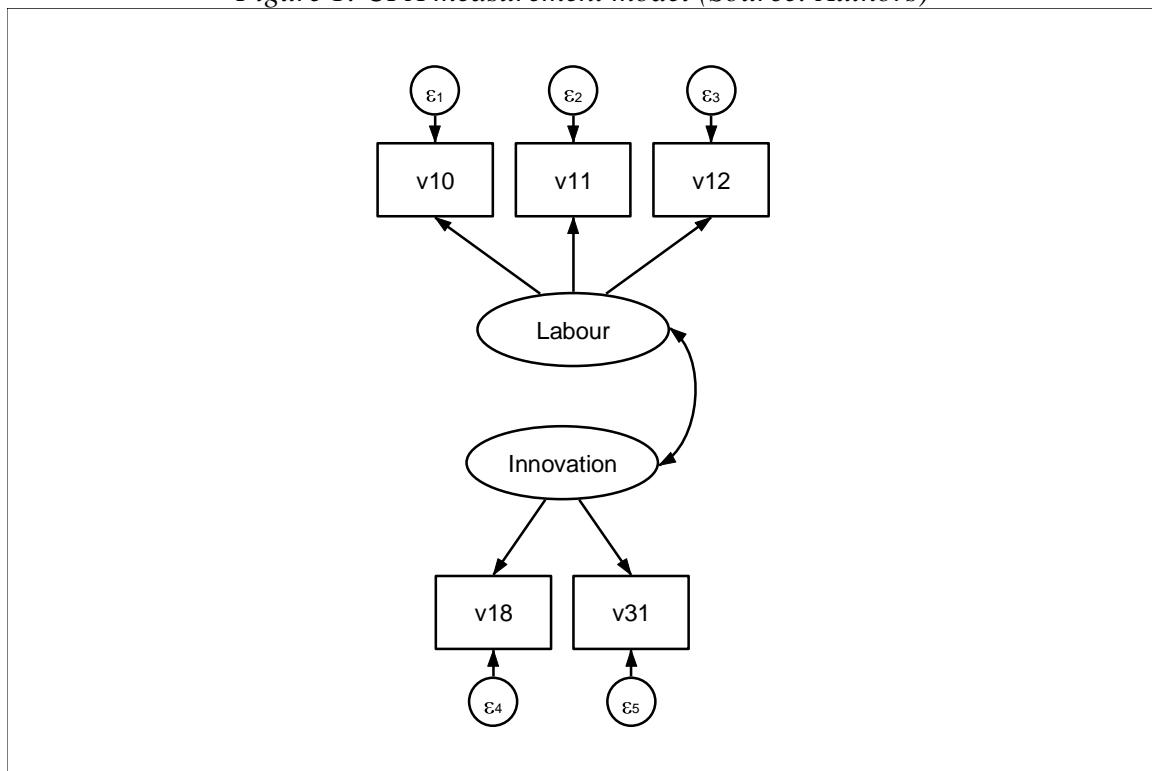

For our measurement model of factors of competitiveness of the European markets we have specified the factors (labour market efficiency and innovation potential) that underlie the variables included in the analysis (see, figure 1). We specified that the covariance of the two/three variables is fully explained by the single latent variable plus the unique variance of each variable.

Table following on the next page

Table 3: Estimation results of a two-factor model (Source: authors' calculations)

Standardized	OIM					[95% Conf. Interval]
	Coef.	Std. Err.	z	P> z		
Measurement						
v10 <-						
Labour	.9424379	.0325746	28.93	0.000	.8785929	1.006283
_cons	1.923474	.3190318	6.03	0.000	1.298183	2.548765
v11 <-						
Labour	-.7999834	.0712015	-11.24	0.000	-.9395357	-.6604311
_cons	13.45106	1.807381	7.44	0.000	9.908661	16.99347
v12 <-						
Labour	.9902278	.0268397	36.89	0.000	.937623	1.042833
_cons	1.184489	.2465118	4.80	0.000	.7013342	1.667643
v18 <-						
Innovation	.632391	.6460366	0.98	0.328	-.6338174	1.898599
_cons	.4885147	.1999396	2.44	0.015	.0966403	.880389
v31 <-						
Innovation	.5564157	.5746094	0.97	0.333	-.569798	1.682629
_cons	1.674726	.2929134	5.72	0.000	1.100626	2.248825
var(e.v10)	.1118108	.0613991			.0381119	.3280251
var(e.v11)	.3600265	.11392			.1936406	.6693798
var(e.v12)	.0194488	.0531548			.0000917	4.123612
var(e.v18)	.6000816	.8170954			.0416083	8.654476
var(e.v31)	.6904015	.6394434			.1123898	4.241081
var(Labour)	1	.			.	.
var(Innovation)	1	.			.	.
cov(Labour, Innovation)	-.182769	.2693494	-0.68	0.497	-.7106841	.3451461

LR test of model vs. saturated:  $\chi^2(13) = 13.01$ , Prob >  $\chi^2 = 0.4468$

Table 3 show the estimation results of our measurement model simultaneously for both sets of variables. We assessed the measurement properties of a scale of labour market efficiency and a scale of innovation potential. The standardized loadings for the measurement of labour market efficiency are 0,94 for Labour → v10, -0,79 for Labour → v11 and 0,99 for Labour → v12 which are all statistically significant. The standardized loading for the measurement of innovation potential appear next and are 0,63 for Innovation → v18 and 0,55 for Innovation → v31 and are not statistically significant. Since our solution is standardized all variables including the latent variables have been rescaled to have a variance of 1,0. The results indicate that the covariance between Labour and Innovation is -0,18,  $p > 0,05$ , which is actually the correlation between our two latent constructs. It is small but statistically not significant correlation. It tells us nothing about the possible direction of influence between these two constructs: we do not know whether greater labour market inefficiency causes lower innovation potential or whether greater innovation potential causes lower labour market inefficiency. This relationship could be entirely spurious if there were some third variable that causes both labour market inefficiency and innovation potential. The estimation results of the model fit with  $\chi^2(13)=13,01$ ,  $p > 0,05$  says our model significantly accounts for the information in the observed covariance matrix. RMSEA=0,01, CFI=1,00 and SRMR=0,08 are all good so we can conclude that the model provides a reasonably good fit to the data.

Table following on the next page

Table 4: Modification indices (Source: authors' calculations)

	MI	df	P>MI	EPC	Standard EPC
Measurement v11 <- Innovation	6.922	1	0.01	.0008773	.4280751
v18 <- Innovation	3248.085	1	0.00	-2.56e+08	-1.62e+08
mean(Innovation)	.	1	.	.	.
cov(e.v10,e.v12)	6.922	1	0.01	30.30435	56.63443
cov(e.v11,e.v31)	7.532	1	0.01	.4237496	.5919428

EPC = expected parameter change

Table 4 shows the modification indices. The first set of modification indices is for the measurement loadings. The biggest modification index among this set is 3248,08 for Innovation → v18. There should be a reasonable justification why variable v18 should be loaded on both latent variables. Variable v18 is about patent application and has a face validity as a variable of Innovation, but on the other hand it has no face validity as a variable of Labour. Therefore, it is not justified to allowing the variable to load on both dimensions. On the other hand, the second set of modification indices is for the error terms to be correlated. Although all these modification indices are greater than 3,84 we should not make any changes unless there is justified reason to do so. Since variables v11 and v31 are both somehow related with employment we continue with correlating both error terms.

Figure 2: Final CFA model (Source: Authors)

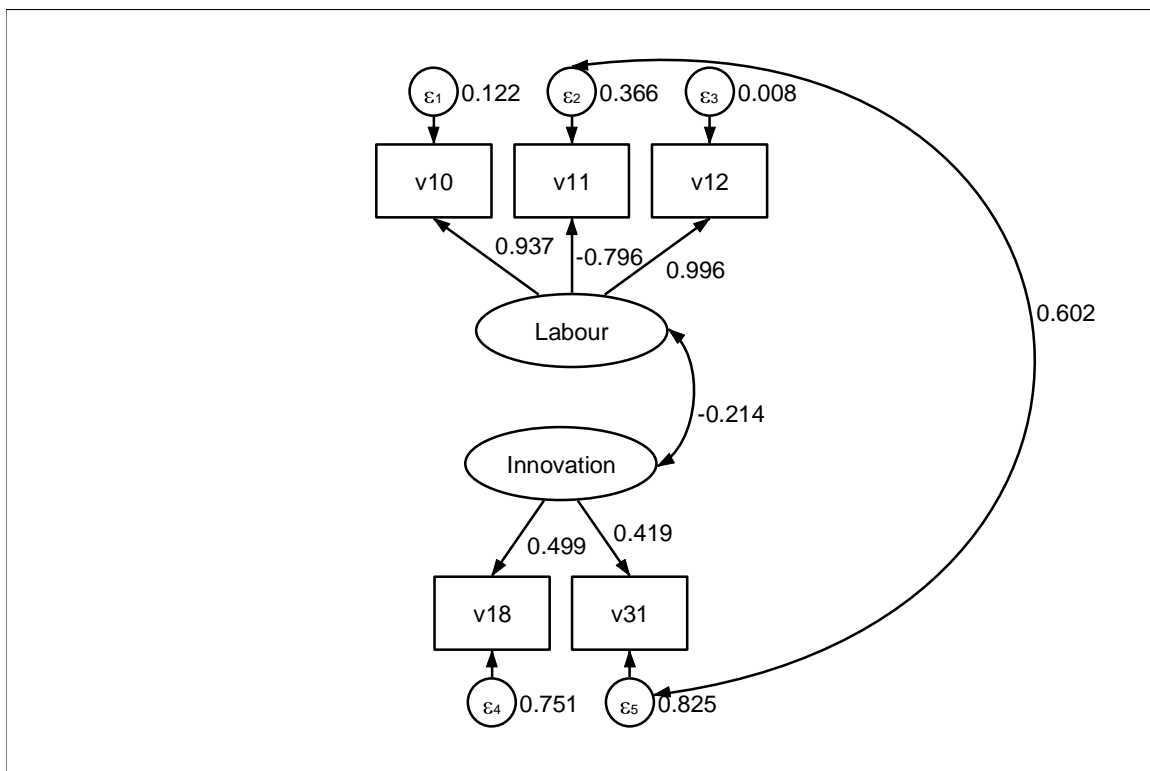

Figure 2 shows our final two-factor CFA model. The loadings of all variables of both latent variables are considered strong, that is greater than 0,40. The estimation results of the model fit with  $\chi^2(13)=3,35$ ,  $p>0,05$  says our model significantly accounts for the information in the observed covariance matrix. RMSEA=0,00, CFI=1,00 and SRMR=0,05 are all good so we can conclude that the model provides a reasonably good fit to the data. The resulting scale reliability is high for Innovation  $\rho_{\text{Innovation}}=0,99$ , whereas for Labour lower  $\rho_{\text{Labour}}=0,28$ .

#### 4. CONCLUSION

Decision to choose the right market for doing business is a strategic decision which affects the performance of the whole company. Decision to enter onto a market has to be carefully planned, on top of that number of different factors have to be considered and which determine whether a company will be successful or not. In order to manage doing business internationally and in a globalized world there is a need to constantly research the dynamics of the company's environment which is diversified and non-controllable and therefore business decisions adapt according to the evolving opportunities, obstacles and constraints in a broader (external) environment of the company. The growing role and importance of the so-called global marketing is forcing companies to take into account certain global trends and factors of external environment, such as economic factors, technological factors, demographic factors, sociocultural factors, political and legal factors, factors that relate to the natural environment. Applying confirmatory factor analysis we have defined two underlying factors of competitiveness of the European markets to support business decision making namely labour market efficiency and innovation potential. Efficient and flexible labour markets contribute to the efficient allocation of resources. Employment and unemployment rates provide information about the level of activity of the European country, while long-term unemployment indicates the presence of structural problems. On the other hand, innovation potential indicates whether a country is at the forefront of new technologies, whether is producing cutting-edge products and processes in order to maintain their competitive advantage.

#### LITERATURE:

1. Acock, A. C. (2013). *Discovering Structural Equation Modeling Using Stata*. Texas: StataCorp.
2. Adams, J. and Juleff, L. (2003). *Managerial Economics for Decision Making*. New York: Palgrave.
3. Baye, M. R. (2010). *Managerial Economics and Business Strategy*. New York: McGraw Hill.
4. Daft, R. L. (2007). *Understanding the Theory and Design of Organizations*. Thomson, Mason: South Western.
5. Drucker, P. F. (2008). *The Five Most Important Questions You Will Ever Ask About Your Organization*. San Francisco: Jossey-Bass.
6. Eurostat Database (available at <https://ec.europa.eu/eurostat/data/database>).
7. Dijkstra, L., Annoni, P. and Kozovska, K. (2011). *A New Regional Competitiveness Index: Theory, Methods and Findings*. Luxembourg: EC.
8. Field, A. P. (2018). *Discovering Statistics Using IBM SPSS Statistics*. London: Sage.
9. Feinberg, F. M., Kinnear, T. C. and Taylor, J. R. (2013). *Modern Marketing Research: Concepts, Methods and Cases*. Melbourne: South-Western.
10. Hollensen, S. (2017). *Global marketing*. Harlow: Pearson.
11. Hollensen, S. (2011). *Global Marketing: A Decision-Oriented Approach*. Harlow: Financial Times, Prentice Hall.
12. Iacobucci, D. (2013). *Marketing Models*. Melbourne: South-Western.
13. IMD (2018). *The World Competitiveness Report*. Lausanne: IMD.

14. Kotler, P. (2016). *Marketing Management*. Harlow: Pearson.
15. Kotler, P. and Armstrong, G. M. (2016). *Principles of Marketing*. Harlow: Pearson.
16. Mankiw, G. (2009). *Macroeconomics*. New York: Worth publishers.
17. Samuelson, W. and Marks, S.G. (2010). *Managerial Economics*. Hoboken: John Wiley.
18. Schmidt, M. and Hollensen, S. (2006). *Marketing Research: An International Approach*. Harlow, New York: Prentice Hall, Financial Times.
19. Schwab, K. (2018). *The Global Competitiveness Report*. Geneva: World Economic Forum.
20. Wilkinson, N. (2005). *Managerial Economics: A Problem Solving Approach*. Cambridge: Cambridge University Press.

# THE EFFECT OF SYSTEMIC STRESS IN THE UNITED STATES ON BILATERAL EXPORTS

**Dejan Romih**

*University of Maribor, Slovenia  
dejan.romih@um.si*

**Peter Mikek**

*Wabash College, United States  
mikekp@wabash.edu*

**Alenka Kavkler**

*University of Maribor, Slovenia  
alenka.kavkler@um.si*

**Silvo Dajcman**

*University of Maribor, Slovenia  
silvo.dajcman@um.si*

## **ABSTRACT**

*The global financial crisis has shown that international trade is not resistant to financial shocks. In this paper, we study the effect of systemic stress in the US on bilateral exports, using the gravity model of international trade. We found that systemic stress in the US has a negative impact on bilateral exports. This finding complements our knowledge of the effects of systemic stress on other economic variables.*

**Keywords:** *bilateral exports, CISS, gravity model of international trade, PPML, systemic stress*

## **1. INTRODUCTION**

Globalisation presents a challenge to economists and policymakers. The global financial crisis led to a dispute between globalists and antiglobalists over financial globalisation. Some economists point out that systemically important financial institutions can act as carriers of a financial contagion. The crisis led to the need for a financial reform. The collapse of the Lehman Brothers sparked antiglobalisation protests in some cities and instilled fear of a chain reaction among economists and policymakers. Financial technology had sped up the process of globalization in the past. The events that followed the collapse of the Lehman Brothers led to speculation about financial deglobalization among economists and policymakers. The crisis showed that financial stability is not a luxury but a necessity. The collapse of the Lehman Brothers caused fear of an L-shaped recession in the United States (US) that spread to other countries. The fear, however, luckily did not materialize. The US was in recession from the last quarter of 2007 to the second quarter of 2009 (V-shaped recession) while the euro area was in recession from the first quarter of 2008 to the second quarter of 2009 and from the third quarter of 2011 to the first quarter of 2013 (W-shaped recession). The global financial crisis led to the need for research on the effects of financial instability on international trade that was severely affected by the crisis. Some studies show that financial instability has a negative effect on certain other economic variables (e.g. GDP or industrial production). However, further research is needed. The global financial crisis also led to the need for a continuous monitoring of systemic risk and systemic stress (i.e. systemic risk that has materialized). This risk is defined by the European Central Bank (2009) as a risk of disturbances in the financial system due to financial instability up to the point where economic growth and welfare suffer greatly. A review of literature shows that it is still uncertain whether and how systemic stress affects certain other



economic variables. The aim of this study is to determine whether and how systemic stress in the US affects bilateral exports. Some studies (e.g. Kiendrebeogo, 2013) show that financial crises in one or both trading partners have a negative effect on such exports. The disadvantage of such studies is that they are based on the use of dummy variables. The advantage of this study is that it is based on the use of the Composite Indicator of Systemic Stress (CISS) for the US. The advantage of the CISS is that it relies on the modern portfolio theory by Harry M. Markowitz, recipient of the 1990 Nobel Memorial Prize in Economic Sciences. Due to the complexity of financial systems there is a need for their macroprudential regulation and supervision. Practice has shown that microprudential regulation and supervision are not enough in order to prevent systemic risk. The global financial crisis caused the need for an expansionary economic policy in the affected countries. This policy contributed to stabilization of the economic position of these countries.

## 2. METHODS

This is an interdisciplinary study. It uses the gravity model of international trade with which it explores the effects of systemic stress in the US on bilateral exports. The model is based on Newton's law of gravitation which states that the gravitational force between two particles is directly proportional to the product of their masses and inversely proportional to the square of the distance between their centers. It can be derived from Gauss's law for gravity and vice versa. Different specifications of this model can be found in literature. Gravity is a physical phenomenon by which all things are brought toward one another due to their mass. There are also other gravitational theories, such as Einstein's which is known as the general theory of relativity. Jan Tinbergen, a recipient of the 1969 Nobel Memorial Prize in Economic Sciences, transferred Newton's theory of gravity to international trade. Anderson (1979) was among the first to explain the gravity model of international trade by using an economic theory, thereby filling the gap and gaining in popularity among researchers. The gravity model of international trade, however, has its disadvantages, since it is based on a physical rather than an economic law. Various studies have been published after 1962 addressing the problem of specification and estimation of gravity models of international trade. Eaton and Kortum (2002) as well as Anderson and van Wincoop (2001) are recognized as the leading authors in the field (Yotov et al., 2016, pp. 12–13). It is also important to point out that the Anderson–van Wincoop gravity model of international trade was used in the study by Santos Silva and Tenreyro (2006) who advocate the use of the Poisson Pseudo-Maximum Likelihood (PPML) estimator. The latter has recently been used by several authors. Besides Santos Silva and Tenreyro, several other authors also contributed to its popularity among researchers, especially Yotov et al. (2016). The estimator is also used in this study. Santos Silva and Tenreyro (2006) found that the PPML estimator is consistent in the presence of heteroskedasticity as well as in the presence of roundoff errors of the dependent variable, both of which present a major problem. Regarding the latter, it must be noted that bilateral trade flows are usually measured in millions or even billions of US dollars, thus resulting in roundoff errors. Santos Silva and Tenreyro (2011) also found that the PPML estimator is also consistent in the presence of a significant number of zeros between the values of the dependent variable. The PPML estimator is also consistent in the presence of overdispersion and underdispersion (Fally, 2015, p. 8). Arvis and Shepherd (2013) found that when applying the PPML estimator the estimated value of international trade equals its true value which, however, does not apply to the use of the Ordinary Least Squares (OLS) and the Gamma Pseudo-Maximum Likelihood (GPML) estimator. Arvis and Shepherd (2013) are convinced that this is another reason for the use of the PPML estimator as a workhorse among the estimators. Gómez-Herrera (2013) believes that each estimator has its advantages as well as disadvantages and that none of them completely outperforms the other.

It has therefore become common practice to estimate each gravity model of international trade with the use of different estimators. Head and Mayer (2014), for example, recommend the use of the OLS, GPML and PPML estimators. They believe that it is not a good idea to have only one workhorse. Anderson and Yotov (2017), for example, used the OLS and PPML estimators in their study. Even though the latter has a number of advantages, Larch et al. (2017) believe that further research is needed still. The data on bilateral exports of goods in current US Dollars have been obtained from the United Nations (2017), the data on the CISS for the US have been obtained from Kremer (2016), and the data on GDP in national currency have been obtained from The World Bank Group (2017). The data on bilateral exchange rates and land area have been obtained from The World Bank Group (2017) as well. The data on population have been obtained from the United Nations (2015), and the data on geographical position of capital cities have been obtained from the latlong.net website. We need the latter to calculate distances between capital cities. When calculating this distance, we use Vincenty's formulae because they provide better results than the formula for the calculation of the great-circle distance, which is more popular among researchers. Other geographical data have been obtained from Stalker and Riches (2016), the data on main languages have been obtained from Simons and Fennig (2017), and the data on trade agreements in force have been obtained from the World Trade Organization (2017). Regarding trade agreements, we consider free trade agreements and the customs union. The RESET test is carried out according to the instructions written by Santos Silva and Tenreyro (2006). The regression is carried out with Stata software and according to the instructions written by Yotov et al. (2016), and the ppml command is used (see Santos Silva and Tenreyro 2011). Country pairs consist of the US and one of the following countries: Australia, Austria, Belgium, Brazil, Canada, the Czech Republic, China, Cyprus, Denmark, Estonia, Finland, France, Germany, Greece, Hong Kong, Iceland, India, Ireland, Israel, Italy, Japan, Latvia, Lithuania, Luxembourg, Malta, Mexico, the Netherlands, New Zealand, Norway, Portugal, Russia, Slovakia, Slovenia, South Africa, South Korea, Spain, Sweden, Switzerland, and the UK. The observed period is from 2000 to 2014. Bilateral exports in 2009 are shown in Figure 1.

*Figure following on the next page*

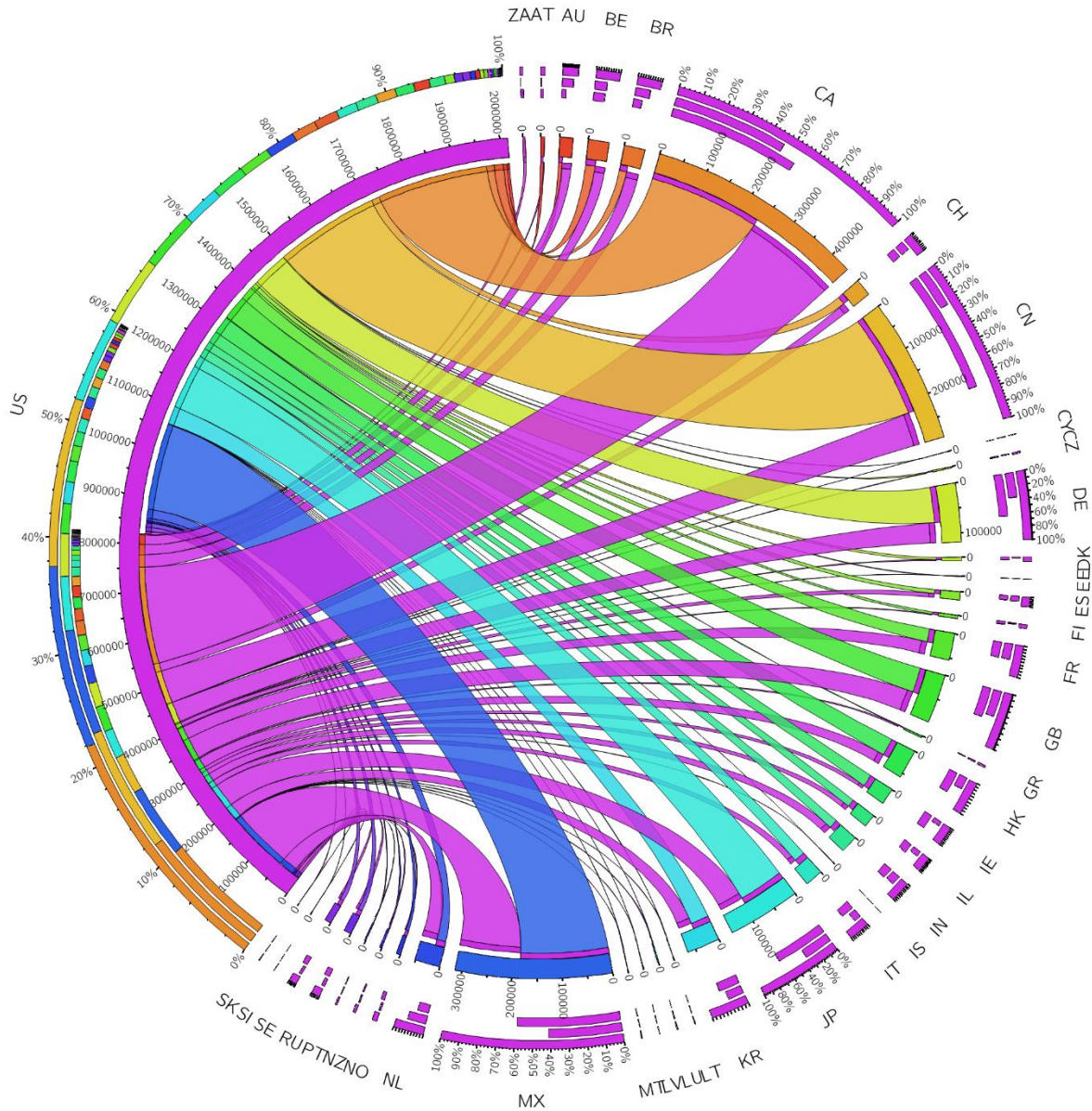

Figure 1: Bilateral exports in 2009 (in million US dollars)

Notes: Australia (AU), Austria (AT), Belgium (BE), Brazil (BR), Canada (CA), the Czech Republic (CZ), China (CN), Cyprus (CY), Denmark (DK), Estonia (EE), Finland (FI), France (FR), Germany (DE), Greece (GR), Hong Kong (HK), Iceland (IS), India (IN), Ireland (IE), Israel (IL), Italy (IT), Japan (JP), Latvia (LV), Lithuania (LT), Luxembourg (LU), Malta (MT), Mexico (MX), the Netherlands (NL), New Zealand (NZ), Norway (NO), Portugal (PT), Russia (RU), Slovakia (SK), Slovenia (SI), South Africa (ZA), South Korea (KR), Spain (ES), Sweden (SE), Switzerland (CH), the UK (GB), the US (US).

### 3. RESULTS

This section gives the results of regression. We fitted the following regression model:

$$y_{ijt} = \beta_0 + \beta_1 \ln x_{1it} + \beta_2 \ln x_{2jt} + \beta_3 \ln x_{3it} + \beta_4 \ln x_{4jt} + \beta_5 \ln x_{5it} + \beta_6 \ln x_{6jt} + \beta_7 \ln x_{7ij} + \beta_8 \ln x_{8t} + \beta_9 x_{9ij} + \beta_{10} x_{10ij} + \beta_{11} x_{11ij} + \beta_{12} x_{12ijt} + \beta_{13} x_{13it} + \beta_{14} x_{14jt} + \beta_{15} x_{15it} + \beta_{16} \ln x_{16it} + \beta_{17} \ln x_{17jt} + \epsilon_{ijt}, i, j = 1, \dots, N, i \neq j, t = 1, \dots, T_{ij}$$

where  $y_{1ijt}$  is the value of exports of goods from country  $i$  to country  $j$  at time  $t$  in current US dollars;  $x_{1it}$  is the value of the GDP of country  $i$  at time  $t$  in current US dollars;  $x_{2jt}$  is the value of the GDP of country  $j$  at time  $t$  in current US dollars;  $x_{3it}$  is the population of country  $i$  at time  $t$ ;  $x_{4jt}$  is the population of country  $j$  at time  $t$ ;  $x_{5it}$  is the land area of country  $i$  at time  $t$  in  $\text{km}^2$ ;  $x_{6jt}$  is the land area of country  $j$  at time  $t$  in  $\text{km}^2$ ;  $x_{7ij}$  is the distance between the capitals of countries  $i$  and  $j$  in km;  $x_{8t}$  is the value of CISS for the US in time  $t$ ;  $x_{9ij}$  is 1, if countries  $i$  and  $j$  are located on the same continent (or share a common land border), otherwise 0;  $x_{10ij}$  is 1, if countries  $i$  and  $j$  share a common language, otherwise 0;  $x_{11ijt}$  is 1, if countries  $i$  and  $j$  are co-signatories of the same trade agreement in time  $t$ , otherwise 0;  $x_{12it}$  is 1, if country  $i$  is a landlocked country, otherwise 0;  $x_{13jt}$  is 1, if country  $j$  is a landlocked country, otherwise 0;  $x_{14it}$  is 1, if country  $i$  is an island country, otherwise 0;  $x_{15jt}$  is 1, if country  $j$  is an island country, otherwise 0;  $x_{16it}$  is the value of the remoteness index for country  $i$  at time  $t$  and  $x_{17jt}$  the value of the remoteness index for country  $j$  at time  $t$ ; and  $\epsilon_{ijt}$  is the standard error term. The remoteness indices were calculated according to the instructions written by Yotov et al. (2016). Descriptive statistics are given in Table 1.

*Table 1: Descriptive statistics*

Variable	Obs	Mean	Std. Dev.	Min	Max
y1	1,201	2.79E+10	5.82E+10	8921328	3.97E+11
lnx1	1,201	28.29696	2.260914	22.18332	30.48709
lnx2	1,201	28.20486	2.283787	22.18332	30.48709
lnx3	1,201	17.95305	2.055007	12.54687	21.03766
lnx4	1,201	17.91661	2.044977	12.54687	21.03766
lnx5	1,201	14.03243	2.64842	5.768321	16.61166
lnx6	1,201	13.97232	2.604008	5.768321	16.61166
lnx7	1,201	8.882225	0.4879343	6.595752	9.676897
lnx8	1,201	-2.176709	0.793011	-3.56815	-0.7974905
x9	1,201	0.0499584	0.2179497	0	1
x10	1,201	0.2373022	0.4256063	0	1
x11	1,201	0.1099084	0.3129059	0	1
x12	1,201	0.0374688	0.1899866	0	1
x13	1,201	0.0499584	0.2179497	0	1
x14	1,201	0.0874271	0.2825776	0	1
x15	1,201	0.0874271	0.2825776	0	1
lnx16	1,201	16.80931	3.008845	9.154306	20.64379
lnx17	1,201	17.57286	3.353809	8.27263	21.32403

*Source: Authors' own calculations.*

*Table following on the next page*

*Table 2: Results of regression*  
*Number of parameters: 16*  
*Number of observations: 1201*  
*Pseudo log-likelihood:  $-3.554E+12$*   
*R-squared: 0.87418002*  
*(Std. Err. adjusted for 81 clusters)*

y1	Coef.	Robust Std. Err.	z	P>z	[95% Conf. Interval]	
lnx1	0.7693378	0.1167623	6.59	0.000	0.5404879	0.9981877
lnx2	0.776863	0.0884659	8.78	0.000	0.6034731	0.950253
lnx3	0.2731867	0.1688495	1.62	0.106	-0.0577522	0.6041256
lnx4	0.1999957	0.1007241	1.99	0.047	0.00258	0.3974113
lnx5	-0.2016836	0.0986153	-2.05	0.041	-0.394966	-0.0084012
lnx6	-0.2065341	0.0620552	-3.33	0.001	-0.3281601	-0.0849081
lnx7	-0.3544249	0.236075	-1.50	0.133	-0.8171233	0.1082736
lnx8	-0.0327019	0.0079769	-4.10	0.000	-0.0483363	-0.0170675
x9	1.437356	0.5949869	2.42	0.016	0.2712033	2.603509
x10	0.3123236	0.2076841	1.50	0.133	-0.0947297	0.7193769
x11	0.4346322	0.2203807	1.97	0.049	0.0026939	0.8665704
x12	-0.9597755	0.3153521	-3.04	0.002	-1.577854	-0.3416967
x13	-1.209203	0.2192715	-5.51	0.000	-1.638967	-0.7794386
x14	-0.0841066	0.3354309	-0.25	0.802	-0.741539	0.5733259
x15	-0.2144421	0.1824629	-1.18	0.240	-0.5720628	0.1431786
lnx16	-0.0687984	0.055255	-1.25	0.213	-0.1770962	.0394994
lnx17	0.0040074	0.033312	0.12	0.904	-0.061283	0.0692977
_cons	-19.70015	4.230946	-4.66	0.000	-27.99265	-11.40765

*Source: Authors' own calculations.*

The results of regression are given in Table 2. It shows that the regression coefficient for variable  $\ln x_{8t}$  (i.e. natural logarithm of the value of the CISS) is negative and statistically significant at the 5% level, which means that systemic stress in the US has a negative effect on bilateral exports. Other results are consistent with our expectations. The regression coefficient for variable  $\ln x_{7ij}$  (i.e. natural logarithm of the distance between the capitals) is negative, but statistically insignificant, which is probably due to the geographical position of the US. It is usually expected that this coefficient will be negative and statistically significant, which would mean that the distance between trading partners has a negative effect on bilateral exports. Obviously, this result depends on the sample. The RESET test does not indicate misspecification of the regression model: the chi-squared statistic is 0.57 ( $p = 0.4512$ ).

#### 4. DISCUSSION

The main finding of this study is that systemic stress in the US has a negative effect on bilateral exports. To our knowledge, this finding has not been reported in the literature. Contrary to this study, Romih, Dajčman and Kavkler (2017) studied the effect of systemic stress in the euro

area on bilateral exports. They found that systemic stress in the euro area has a negative effect on bilateral exports. Both studies complement the literature on the effects of systemic stress on other economic variables. They show that macroprudential regulation and supervision are needed. The global financial crisis has contributed to improving the situation in this field. Knowledge of behavioral finance is important for further research.

#### **LITERATURE:**

1. Anderson, J. E. (1979). A Theoretical Foundation for the Gravity Equation. *American Economic Review*, 69 (1), pp. 106–116.
2. Anderson, J. E., and van Wincoop, E. (2001). Gravity with Gravititas: A Solution to the Border Puzzle. NBER Working Paper No. 8079. Cambridge: National Bureau of Economic Research.
3. Anderson, J. E., and Yotov, Y. V. (2016). Terms of Trade and Global Efficiency Effects of Free Trade Agreements, 1990–2002. *Journal of International Economics*, 99, pp. 279–298.
4. Arvis, J.-F., and Shepherd, B. (2013). The Poisson Quasi-Maximum Likelihood Estimator: A Solution to the ‘Adding up’ Problem in Gravity Models. *Applied Economic Letters*, 20 (6), pp. 515–519.
5. Eaton, J., Kortum, S., Neiman, B., and Romalis, J. (2016). Trade and the Global Recession. *American Economic Review*, 106 (11), pp. 3401–3438.
6. European Central Bank (2009). *Financial Stability Review*, December 2009, [https://www.ecb.europa.eu/pub/pdf/fsr/art/ecb.fsrart200912\\_02.en.pdf?39462a69bb594e9a7f14091c0085c132](https://www.ecb.europa.eu/pub/pdf/fsr/art/ecb.fsrart200912_02.en.pdf?39462a69bb594e9a7f14091c0085c132).
7. Fally, T. (2015). Structural Gravity Model and Fixed Effects. NBER Working Paper 21212. Cambridge: National Bureau of Economic Research.
8. Gómez-Herrera, E. (2013). Comparing Alternative Methods to Estimate Gravity Models of Bilateral Trade. *Empirical Econometrics*, 44 (3), pp. 1087–1111.
9. Head, K., and Mayer, T. (2014). Gravity Equations: Workhorse, Toolkit, and Cookbook. In Gopinath, G., Helpman, E., and Rogoff, K. (Eds.), *Handbook of International Economics*, Volume 4 (pp. 131–195). Amsterdam: Elsevier.
10. Kiendrebeogo, Y. (2013). How Do Banking Crises Affect Bilateral Exports? IMF Working Paper 13/150. Washington: International Monetary Fund.
11. Kremer, M. (2016). Financial Stress Indices: An Introduction. *The Spanish Review of Financial Economics*, 14 (1), pp. 1–4.
12. Romih, D., Dajčman, S., and Kavkler, A. (2017). Does Systemic Financial Stress in the Euro Area Have a Negative Impact on Bilateral Exports? In Cingula, M. (Ed.), Przygoda, M. (Ed.), and Detelj, K. (Ed.), *Economic and Social Development: 23rd International Scientific Conference on Economic and Social Development: Book of Proceedings* (pp. 28–37), Varazdin: Varazdin Development and Entrepreneurship Agency; Koprivnica: University North; Warsaw: Faculty of Management.
13. Santos Silva, J. M. C., and Tenreyro, S. (2006). The Log of Gravity. *The Review of Economics and Statistics*, 88 (4), pp. 641–658.
14. Santos Silva, J. M. C., and Tenreyro, S. (2011). Further Simulation Evidence on the Performance of the Poisson Pseudo-Maximum Likelihood Estimator, *Economics Letters*, 112 (2), pp. 220–222.
15. Simons, Gary F., and Fennig, C. D. (Eds.) (2017). *Ethnologue: Languages of the World*, Twentieth edition. Dallas: SIL International.
16. Stalker, P., and Riches, C. (2016). *A Guide to Countries of the World*, Fourth Edition. Oxford: Oxford University Press.
17. The World Bank Group (2017). *World Development Indicators*, <http://databank.worldbank.org/data/reports.aspx?source=world-development-indicators>.

18. United Nations (2015). World Population Prospects: The 2015 Revision, <https://esa.un.org/unpd/wpp/>.
19. United Nations (2017). UN Comtrade Database, <https://comtrade.un.org/>.
20. World Trade Organization (2017). List of All RTAs, <http://rtais.wto.org/UI/PublicAllRTAList.aspx>.
21. Yotov, Y. V., Piermartini, R., Monteiro, J.-A., and Larch, M. (2016). An Advanced Guide to Trade Policy Analysis: The Structural Gravity Model. Geneva: World Trade Organization.

## RETHINKING THE NEOLIBERAL PRESCRIPTIONS OF STATE-BUILDING: THE CASE OF BOSNIA AND HERZEGOVINA

**Bora Besgul**

*Corvinus University of Budapest, Budapest, Hungary*  
*bora.besgul@gmail.com*

**Melek Aylin Ozoflu**

*Corvinus University of Budapest, Budapest, Hungary*  
*melekaylinzoflu@gmail.com*

### **ABSTRACT**

*Despite the long years of political, economic and military presence of the international community with its remarkable amount of aid in post-conflict Bosnia and Herzegovina (BiH) is still one of the most divided societies in Europe which include ethnic competitions, decentralized political instabilities, lack of economic growth and high rates of unemployment. The current state structure was put forward by the Dayton Peace Accords signed in 1995 to end the violent war turning out an ethnic cleansing and caused unforgettable humanitarian and economic loss. The Dayton vision for the BiH was based on the neoliberal agenda which put a strong emphasis on the belief that ethnic harmony and sustainable peace would only be achieved through a reconstruction programme of neoliberal policies e.g. liberal democracy and open market economy. However, ethnic collective identities between contending groups are still seen to be the major obstacle to reach an upper level of shared collective identity. With this regard, this paper aims to discuss the effectiveness- or ineffectiveness- of Dayton recipe for BiH to build a functional and sovereign state along with an upper level of shared collective identity.*

**Keywords:** *Bosnia and Herzegovina, collective identity, Dayton Peace Accords, neoliberal restructuring*

### **1. INTRODUCTION**

BiH where -mainly- three different and conflicting memories; three different ethnic collective identities with no common vision for present and future for the country have been trying to build a peaceful upper level of shared collective identity since Dayton Peace Accords, is a unique example of the debate over the reconstruction of a functional state with its challenge posing to international actors. The Dayton based on the idea that Bosnia, by achieving liberal democracy and market economy, would finally preserve peace and unite Orthodox Christian Serbs, Roman Catholic Croats and Muslim Bosniaks in one shared identity. In this sense, regarding the current and from the very moment of its enforcement- fervent debates, whether the rhetoric aims of Dayton vision dictated by the liberal West have been consistent with the idea of reconstructing a functional state is highly open to discussion and seemed challenging because of the strong existent ethnic self-identifications. Therefore, this paper would try to answer the question whether BiH could formulate any inclusive prescription of shared collective identity as a cure for the chasm within its boundaries and reconstruct a functional state of Bosnia and Herzegovina. When the Cold War was about to end, the situation in the Socialist Federal Republic of Yugoslavia (SFRY) became a bitter context in which elite struggles over the future of the Yugoslav system emerged. These struggles indeed were originated from a sharp division of reformists and conservatives in the League of Communists of Yugoslavia over the need of reform in political and economic structures from the 1960s<sup>1</sup>.

---

<sup>1</sup> Gagnon, V. (2010). Yugoslavia in 1989 and after. *Nationalities Papers*, 38(1), 23-39, p.25.



While reformists were in favor of more reliance on market mechanisms and of decentralization, conservatives argued that it would damage the socialist system by increasing nationalism. To equate the different aspirations between six republics, constitutional amendments have been applied in 1967/71 leading political and economic decentralization of the State<sup>2</sup>. Within this certain extent of decentralized structure, Tito's successful management of developing an efficient federal model based on equal representation of the republics did succeed in settling in the competition of nationalist aspirations between republics -mainly between Belgrade and Zagreb- until Tito's death in 1980<sup>3</sup>. Accordingly, when 1980 became the year of the inefficient economic system combined with the global economic recession, there appeared the question of whether Tito's death meant SFRY's death too. Deepening crisis was followed by the different endeavors -between building a confederation, loose federation or recentralization- for the future of the Yugoslav system. Unfortunately, any common ground for reconciliation between the parties could not be found and it turned into violent clashes of elites for the control over and access to power resources<sup>4</sup>. As a result, elite factions began to align themselves with their own 'ethnicity' with the usage of ethnic labels for the sake of political interests. By converting their discourses from 'Yugoslavism' to 'ethnic identity', people previously searching for the options for the survival of the SFRY would become the main heroes of dissolution of the SFRY. Remarkably, it is worthwhile to highlight that although 'ethnic hatred' is usually associated with the reason of the dissolution, it did not play the main role. On the contrary, it is the political struggles of the elites that brought about both ethnic hatreds and the dissolution of the SFRY. Investigating the source of conflict in Bosnia reveals that both the ethnicity and the religious differences have played an essential role in generating the conflict. Accordingly, each ethnic group considered the religion as a mean to shape and secure their own ethnic/religious culture and tradition. In that sense, ethnic and religious differences became the key factor and tool of shaping the communities into hate and hostility. One of the characteristics of the Bosnian war was the systematic destruction of mosques, graveyards, and other religious and cultural monuments. "Of those, 1284 were Islamic sacred and other objects, 237 Catholic, and 30 Orthodox."<sup>5</sup> Correspondingly, it stimulates the social memory which strongly associated with religion and cultivates the deeply rooted conflict (i.e. religious ingroups) and interrupts the possible integration of groups into a political collective identity of BiH, which aims to unite all of the ethnic groups in a religiously tolerant neutral position.

## 2. INTERNATIONAL STATE BUILDING IN BIH AND DAYTON PEACE ACCORDS

The Bosnian referendum in November 1991 marked a point of the beginning of the no return for the preservation of the multi-ethnicity and multi-culturalism that could be well reestablished in the State, in which the Muslim Alija Izetbegovic became president. Having rejected results of the referendum followed with Serbian Propaganda by alleging that Izetbegovic is an Islamic fundamentalist, the Bosnian Serbs mobilized their forces leading Europe's most violent conflict since World War II<sup>6</sup>. The very complex nature of the conflict by being an internal struggle along with an international struggle between Serbia, Bosnia, and Croatia impeded the effective process of intervening and negotiating<sup>7</sup>. When the NATO intervened, there had been already a huge humanitarian and economic loss leaving a war-torn country to be reconstructed and

---

<sup>2</sup> Korkut, H., & Mulalić, M. (2009). Implications of Dayton Peace Agreement on Current Political Issues in Bosnia-Herzegovina. *Süleyman Demirel Üniversitesi Fen-Edebiyat Fakültesi Sosyal Bilimler Dergisi*, 2009(2) p.108.

<sup>3</sup> Gültekin, V. (2011). *Neoliberal Recipes to the Post-Conflict Bosnia-Herzegovina: The Case of Privatizations* (Doctoral dissertation, Middle East Technical University) p.11.

<sup>4</sup> Gagnon, *op.cit.*, p.24.

<sup>5</sup> Bublin, M. (1999). *Gradovi Bosne i Hercegovine: milenijum razvoja i godine urbičida*. Sarajevo-Publishing. p. 243.

<sup>6</sup> Rohde, D. (2012). *Endgame: the betrayal and fall of Srebrenica, Europe's worst massacre since World War II*.

<sup>7</sup> Roubini, S. (2012). *Education, Citizenship, Political Participation: Defining Variables for Post-Conflict Reconstruction in Bosnia-Herzegovina* (Doctoral dissertation, Oberlin College) p.45.

rehabilitated with a traumatized community whose traumatic experiences would be transmitted to next generation(s)<sup>7</sup>. In that context, the United States (US) has proposed a ‘peace agreement’ based on the neo-liberal recipe to be negotiated by the parties. Three and a half years of brutal ethnic conflict ended with the signing of Dayton Peace Accords (DPA) which came into force in 1995. Since it was outlined basically with the aims of ending the conflict and reconstructing the Bosnian state, the Constitution of BiH<sup>8</sup> was annexed to the DPA. In this sense, The DPA has become the most important international tool – after military measures- in reconstructing a functional BiH. The alleged Dayton vision was in line with the neoliberal agenda and it did foresee “liberal democracy and peaceful co-existence based on market economy in BiH”<sup>9</sup>. The political structure of DPA has created a very complex multi-layered structure of administrative and institutional system incorporating four layers of administrative units in partly autonomous entities; Federation of Bosnia and Herzegovina (FBiH) and Republika Srpska (RS) for the sake of satisfying demands of the all entities in power-sharing<sup>10</sup>. In fact, it intended to build a nation in Bosnia based on the principle of one state and one nation to which all three nationalities should owe allegiance. In this way, the division based on ethnonationalism was sealed by the DPA. Moreover, Reconstruction and Recovery program was formulated in line with neoliberal agenda to facilitate transition from a war economy to a peace economy and from a command economy to a market economy with the involvement of the Bretton Woods and European Bank for Reconstruction and Development<sup>11</sup>. In a nutshell, the neoliberal recipe to the post-conflict Bosnia aims to include “... to create multi-ethnic and democratic institutions to ensure fundamental human rights and the rule of law; to provide for post-conflict reconstruction toward sustainable peace for BiH; to prevent the recurrence of the conflict or its potential spill-over in the region”<sup>12</sup>. However, the positive rhetoric and framework of the DPA that have been drawn so far are just one side of the coin because of the fact that over 23 years after the implementation of the DPA, the BiH is still suffering from its transition process into a self-sustainable and self-governing functional State, which aims to combine the constituent groups into one single wider collective identity. In this regard, it might be worthwhile to identify the inefficiencies of the system designated by DPA. To this end, this next section will shed light on the Bosnian reconstruction programme in order to understand the current state affairs of BiH. Briefly, DPA has created a federation with a complex administrative structure which consists of three constituent people in the state. “In the Preamble to the Constitution, Bosniacs, Croats and Serbs are described as constituent peoples”. The three-person Presidency resides of a Serb from RS and a Bosniak and a Croat elected from the Federation FBiH. The House of Peoples consists of 15 delegates “two-thirds from the Federation (five Croats and five Bosniacs) and onethird from the Republika Srpska (five Serbs)’ [Annex 4, Article 1, paragraph 1 of Dayton Peace Agreement]. In fact, Bosnian system is seen to be more confusing when it is considered that the majority of delegates from any constituent groups have the power to veto over parliamentary decisions in order to protect the ethnic-based national interests. The aim of the agreement was also establishing a buffer-country between other less friendly powers on the Balkan. The founder international actors had foreseen that some years of helping the Bosnian Parliament from outside would be enough to create a stable and operable political system for managing the

---

<sup>7</sup> Lovrenović, D. (2016). Bosnia and Herzegovina as the Stage of Three Parallel and Conflicted Historical Memories. *European Review*, 24(4), 481-490, p.484.

<sup>8</sup> To see the Constitution of Bosnia and Herzegovina; <http://hrlibrary.umn.edu/icty/dayton/daytonannex4.html> (Access on 19.10.2018)

<sup>9</sup> Gültekin, V., *op.cit.*, p.15.

<sup>10</sup> Önsoy, M. (2011). Coping with Bosnia-Herzegovina’s critical problems: Reconsidering the international community’s role. *Uluslararası Hukuk ve Politika*, (25), 121-150, p.122.

<sup>11</sup> Gültekin, *op.cit.*, p. 15.

<sup>12</sup> Korkut, H., & Mulalić, M., *op.cit.*, p.108.

country. The failure of this strategy, which was caused mostly by the missing political experiences, motivation, and knowledge of the local politicians, showed that decision-makers of international interests ignored the real needs and demands of the different ethnic groups. Moreover, the DPA was not only a classic peace contract but also a manuscript for a new State created in the agreement<sup>13</sup>, a new functional state. There has been a strong belief in the International Community's motive is that peace and sustainability could only be assured through economic growth and development<sup>14</sup>. At the same time, having been faced with the mass collapse of Eastern bloc, the West had no choice but to use of prescriptions of the Washington Consensus and Shock Therapy<sup>15</sup>. Therefore, they insisted on adopting the neo-liberal strategy regardless of the fact of its being doomed-to-fail nature. The adoption of the strategy based on the one-size-fitsall strategy which is lacking the notion that BiH was not only a post-conflict but also a postcommunist State<sup>16</sup>. Main pillars of this neo-liberal restructuring programme would be stabilization, liberalization, and privatization. Over the years, the rates of growth, of unemployment and of GDP along with other economic and political indicators demonstrated that the reconstruction and recovery program could not achieve much so far. The high expectations especially for employment generation, sustainable development in a sustainable peace and viable economy could not be fulfilled by the neoliberal agenda. The flow of aid within the programme has strengthened local elites emerged from the war due to their capability and willing to impose neoliberal visions of the Dayton and due to their overlapping interests with the international actors<sup>17</sup>. However, that did only help consolidate the power of elites and division of control over power resources. Additionally, the adoption of main pillars namely stabilization, liberalization, and privatization caused only a further polarization based on ethnicity within the society. Apparently, the international actors- too busy in the realization of the neoliberal principles- did ignore the sociological aspects of the reconstruction process and the need to reconstruct trust among different ethnic identities to re-unify citizens, who were traumatized and exposed to insecurity within society, towards a multi-ethnic functional BiH.<sup>18</sup> For example, the privatization process i.e. the sales of the apartments and enterprises were carried out based on ethnic lines<sup>19</sup>. Especially, the privatization of apartments accelerated ethnic homogenization on a territorial basis<sup>21</sup> that would further disconnect the interaction among different identities which causes the continuation of domestic disintegration and the underestimation of rebuilding a multi-ethnicity. Besides these neoliberal principles, DPA has also aimed to create a nation-state by using the citizenship as an integrative instrument, in which bridges the differences of contending groups in the collective identity of BiH. "Such shared citizenship is expected to generate a collective identity that supersedes rival identities – ethnic/religious identities - induced by cultural diversity and differences in social status."<sup>20</sup>. Accordingly, the concept of citizenship based collective identity shifts the focus of collective identity from social to the political domain in which political collective identity but the essence of the political collective identity often remains dubious, as many scholars argue that the bonds between citizens without explaining the source of this feeling and its implications. It is more likely to happen in the countries established as an ethnically and deeply fragmented society

---

<sup>13</sup> Torsti, P. (2003). Divergent stories, convergent attitudes: Study on the presence of history, history textbooks, and the thinking of youth in post-war Bosnia and Herzegovina.

<sup>14</sup> Gültekin, *op.cit.*, p. 19.

<sup>15</sup> *Ibid.*

<sup>16</sup> *Ibid.*, p.20

<sup>17</sup> *Ibid.*, p. 16.

<sup>18</sup> Roubini, S., *op.cit.*, p.4.

<sup>19</sup> Gültekin, *op.cit.*, p.

79. <sup>21</sup> *Ibid.*, p.86.

<sup>20</sup> Karolewski, I. P. (2009). *Citizenship and collective identity in Europe*. Routledge. <sup>23</sup> *Ibid.*, p.4.

such as BiH. Investigating the all of the constituent communities; Bosniaks, Serbs, and Croats, we can notice that these characteristics of the ethnic community have been used in political rhetoric and an educational system that facilitates the integration of the younger generations in the logic of desired thinking and action of the politics of ethnicity. As a result, it reproduces the ethnic\religious cleavage between communities and increases the social distance among them. The winners of this homogenization were local political actors who gained ethnic-based support in the elections<sup>23</sup>. When the ethnic cleavages set, the tendency to lead people to a political conflict is common since politicized identity is prone to let politicians/elites make use of influence over society to construct new concepts, beliefs, theories, myths in the name of ethnonationalism. Ignatieff stated that “nationalism does not simply express a pre-existent identity: it constitutes a new one.”<sup>21</sup>. That is the reason, ethnicity\religion-oriented parties have attempted to control and create desired to think and action to canalize the society into a much more hostile the in-group. As a result, in order to claim political credit, nationalist actors both have applied to use of ethnic politics and reconstructed hostility thereby increasing the feeling of hate between communities. In this sense, ethnic policies tend to use, especially, the utilized interpretation of the conflict of devastating Bosnian wars by portraying other groups (out groups) as murders, rapists, barbaric, or as intruders. Overall, the vision designed by the DPA increased and reinforced polarization based on ethnic division in the BiH. The different perspectives of the different ethnic groups consolidated the polarization which is the root cause of the stalemate in Bosnian politics. Indeed, this presents a vicious circle, as long as they try to reach an agreement to resolve the current paralysis of the State they will result in failure. Because each ethnic group acts to pursue its own interests. Respectively; Bosnian Serbs who committed ethnic cleansing<sup>22</sup> were rewarded with a ‘republic’ so they try to preserve its given status and to keep the status quo as a resistance to the centralization of the State. Bosnian Muslims who could not win a unitary State<sup>23</sup> advocate more centralized and strong state and abolishment of all entities. Bosnian Croats who were deemed to share an entity with Bosnian Muslims<sup>24</sup> aim to form their own entity as a third one and to resist to the centralization of State. This deep polarization, however, would only be dissolved by reaching an agreement for the sake of functional BiH. Within this polarization of the society and acceleration of the problems, there have been clear signs of the need to ‘reform’ especially a constitutional one. On the other hand, here it is important to highlight the emerging fact that BiH is not capable of even designating an action plan towards a functional state on its own which is the strong proof that it “...would not exist today as a state but for international support”<sup>25</sup>. Although international actors could not achieve any concrete results on the way to constitutional reform, the internal political crisis of BiH along with the ongoing deadlock in decision-making and the resistance to reform pushed EU and US to formulate a transatlantic proposal in 2009<sup>26</sup>. Indeed, their underlying motive has been the fact that the problems in BiH came to the point which cannot be ignored otherwise would damage to the actorness of the both EU and the US in conflict resolution<sup>30</sup>. As a result, the process included a constitutional reform package in order to make BiH – dubiously- more functional state towards a prospective accession the EU. The reform package aimed to increase central state authority by allocating the power from entity level to

---

<sup>21</sup> Ignatieff, M. (1998). *The warrior's honor: Ethnic war and the modern conscience*. Macmillan.

<sup>22</sup> Korkut, & Mulalić, *op.cit.*, p.112.

<sup>23</sup> Perry, V. (2015). Constitutional Reform in Bosnia and Herzegovina: Does the Road to Confederation go through the EU?. *International Peacekeeping*, 22(5), 490-510, p. 491.

<sup>24</sup> Korkut, & Mulalić, *op.cit.*, p.112.

<sup>25</sup> Bose, S. (2002). *Bosnia after Dayton: Nationalist partition and international intervention*. Oxford University Press., p.22.

<sup>26</sup> Türkeş, M., Rüma, Ş. İ., Akşit, S., & Açar, D. A. (2012). Kriz Sarmalında Bosna-Hersek: “Devlet Krizi”. *Cycles of crises in Bosnia-Herzegovina: the 'state crisis' ], Boğaziçi Üniversitesi-TÜSİAD Dış Politika Forumu Araştırma Raporu, DPF*, 1-55, p.25. <sup>30</sup> *Ibid.*

the national level<sup>27</sup>. Being prepared only with minimal coordination with the locals, the proposal was rejected by most of the Bosnian leaders<sup>28</sup>. Generally, the constitutional reform process turned out a deadlock in which the failure was following failure and no neo-liberal recipe was of use. The reason for this stalemate might be categorized in two aspects. Firstly, different interpretations of the three ethnic groups; Bosnian Serbs view them as a threat to its given 'republic', Bosnian Muslims view them as a chance for its domination over other entities and Some Croats try to use it to open the debate of forming a third entity.<sup>29</sup> Secondly, EU's failure to use its incentives efficiently resulting in the lack of local actors' will reach an agreement with other entities for a slight chance of EU membership<sup>30</sup>. On the other hand, recently there have been promising signs regarding the integration to the EU. After the entry into the force of EU's Stabilization and Association Agreement in 2015 to build close political, economic and trade relations between two parties<sup>31</sup>, BiH submitted its application to join EU in February 2016<sup>32</sup>. It was accepted with EU Council's invitation to the European Commission to submit its opinion on the EU membership application of Bosnia and Herzegovina<sup>33</sup>. The coincidentally(?) date of the invitation, however, raised the question of whether it has been an attempt of the EU to halt the RS's referendum on the 'Statehood Day'- whether to keep it- which has been another watershed event of the year for the BiH. If so, it could not influence and altered the non-reconciliatory attitude of the Bosnian Serbs political leaders. The EU and the US opposed the referendum on the grounds that it would violate the DPA. Furthermore, it was against the court ruling indicating that it would discriminate non-Serbs (mainly Bosnian Muslims and Bosnian Croats) since the date falls on when Bosnian Serbs declared the creation of their own State within Bosnia in 1992<sup>34</sup>. Therefore, it received harsh criticisms both from internal and from international political actors. Besides, it was also interpreted as a possibility of a dress rehearsal for the referendum on the independence of RS. Nevertheless, the result of the referendum was %99.8 in favor of keeping the date as a national holiday.<sup>35</sup> On the one hand, it reawakened fears of unrest in the society. On the other hand, internal politics, which had been expected to settle down with the favorable EU decision towards an accession, was shaken and exacerbated by the referendum. In this sense, it will highly cause further disintegration and destabilization. For this reason, "... the political scene of BiH is almost the same as it was in 1991 with its political leaders' non-reconciliatory attitude"<sup>36</sup>

### 3. CONCLUSION

Overall, the DPA for BiH to build a functional and sovereign state based on neoliberal principles along with an upper level of collective identity presents a challenging attempt. This paper finds out that the existent cleavages (in groups) based on different aspects strongly hinder to reach a potential shared collective identity in BiH. Accordingly, created artificial state seems to be not enough to end existing cleavages in BiH, since it does not supersede the existing rival

---

<sup>27</sup> *Ibid.*, p.26.

<sup>28</sup> Tolksdorf, D. (2015). The European Union as a Mediator in Constitutional Reform Negotiations in Bosnia and Herzegovina: The Failure of Conditionality in the Context of Intransigent Local Politics. *Nationalism and Ethnic Politics*, 21(4), 401-421, p.410.

<sup>29</sup> Still this is not desired by majority of the Croats. They claim that it will legitimize the current Serb controlled areas to RS.

<sup>30</sup> *Ibid.*, p 415.

<sup>31</sup> [http://ec.europa.eu/neighbourhood-enlargement/countries/detailed-country-information/bosnia-herzegovina\\_en](http://ec.europa.eu/neighbourhood-enlargement/countries/detailed-country-information/bosnia-herzegovina_en), (Access on 20.10.2018)

<sup>32</sup> Bosnia and Herzegovina 2016 Progress Report, Brussels, European Commission Report, 2016, [http://ec.europa.eu/neighbourhoodenlargement/sites/near/files/pdf/key\\_documents/2016/20161109\\_report\\_bosnia\\_and\\_herzegovina.pdf](http://ec.europa.eu/neighbourhoodenlargement/sites/near/files/pdf/key_documents/2016/20161109_report_bosnia_and_herzegovina.pdf). (Accessed on 20.10.2018).

<sup>33</sup> *Ibid.*

<sup>34</sup> "Bosnian Serbs Defy State with Referendum Landslide", *Balkaninsight*, <http://www.balkaninsight.com/en/article/republikasrska-referendum-early-results-09-25-2016>. (Accessed on 20.10.2018).

<sup>35</sup> *Ibid.*

<sup>36</sup> Lovrenic, *op.cit.*, p. 481.

identities (ethnic/religious). The current political dynamics of BiH present three constituent peoples, two entities, one state and no shared vision of the present or future with three different and conflicting memories, three different collective identities, three different perspectives for the state and three different views for the future which are combined with neo-liberal capitalism and ethnonationalism. The contending groups focusing their own ethnic/national de-facto entities utilize interpretations of conflict by portraying other groups as murders, rapists, intruders. That drags societies inevitably into hate and hostility. Besides, the weakened power of the central government as against the strong entities result in the community's agenda being dominated by the ethnic politics that does not give priority to the problems of the BiH as the state level. Thus, ethnicity and religion provide more collectivism than state citizenship can provide. To conclude, the internationally designed Dayton Peace Agreement's aim to transform a war-torn country to a functional state where democracy, human rights, multi-ethnic society would be assured, remained as only a naive rhetoric. However, that does not mean that neoliberal restructuring based on stabilization, liberalization, and privatization could not be achieved in BiH.

#### LITERATURE:

1. "Bosnian Serbs Defy State with Referendum Landslide", Balkaninsight, <http://www.balkaninsight.com/en/article/republika-srpska-referendum-early-results-09-25-2016>. (Accessed on 20.10.2018).
2. Bose, S. (2002). *Bosnia after Dayton: Nationalist partition and international intervention*. Oxford University Press.
3. Bosnia and Herzegovina 2016 Progress Report, Brussels, European Commission Report, 2016, [http://ec.europa.eu/neighbourhoodenlargement/sites/near/files/pdf/key\\_documents/2016/20161109\\_report\\_bosnia\\_and\\_herzegovina.pdf](http://ec.europa.eu/neighbourhoodenlargement/sites/near/files/pdf/key_documents/2016/20161109_report_bosnia_and_herzegovina.pdf). (Accessed on 20.10.2018).
4. Bublin, M. (1999). *Gradovi Bosne i Hercegovine: milenijum razvoja i godine urbičida*. SarajevoPublishing.
5. Constitution of Bosnia and Herzegovina; <http://hrlibrary.umn.edu/icty/dayton/daytonannex4.html> (Access on 19.10.2018)
6. Gagnon, V. (2010). Yugoslavia in 1989 and after. *Nationalities Papers*, 38(1), 23-39.
7. Gültekin, V. (2011). *Neoliberal Recipes to the Post-Conflict Bosnia-Herzegovina: The Case of Privatizations* (Doctoral dissertation, Middle East Technical University).
8. [http://ec.europa.eu/neighbourhood-enlargement/countries/detailed-country-information/bosniaherzegovina\\_en](http://ec.europa.eu/neighbourhood-enlargement/countries/detailed-country-information/bosniaherzegovina_en), (Access on 20.10.2018).
9. Ignatieff, M. (1998). *The warrior's honor: Ethnic war and the modern conscience*. Macmillan.
10. Karolewski, I. P. (2009). *Citizenship and collective identity in Europe*. Routledge.
11. Korkut, H., & Mulalić, M. (2009). Implications of Dayton Peace Agreement on Current Political Issues in Bosnia-Herzegovina. *Süleyman Demirel Üniversitesi Fen-Edebiyat Fakültesi Sosyal Bilimler Dergisi*, 2009(2).
12. Lovrenović, D. (2016). Bosnia and Herzegovina as the Stage of Three Parallel and Conflicted Historical Memories. *European Review*, 24(4), 481-490.
13. Önsoy, M. (2011). Coping with Bosnia-Herzegovina's critical problems: Reconsidering the international community's role. *Uluslararası Hukuk ve Politika*, (25), 121-150.
14. Perry, V. (2015). Constitutional Reform in Bosnia and Herzegovina: Does the Road to Confederation go through the EU?. *International Peacekeeping*, 22(5), 490-510.
15. Rohde, D. (2012). *Endgame: the betrayal and fall of Srebrenica, Europe's worst massacre since World War II*. Penguin.

16. Roubini, S. (2012). *Education, Citizenship, Political Participation: Defining Variables for PostConflict Reconstruction in Bosnia-Herzegovina* (Doctoral dissertation, Oberlin College).
17. Tolksdorf, D. (2015). The European Union as a Mediator in Constitutional Reform Negotiations in Bosnia and Herzegovina: The Failure of Conditionality in the Context of Intransigent Local Politics. *Nationalism and Ethnic Politics*, 21(4), 401-421.
18. Torsti, P. (2003). *Divergent stories, convergent attitudes: Study on the presence of history, history textbooks, and the thinking of youth in post-war Bosnia and Herzegovina*. Taifuuni.
19. Türkeş, M., Rüma, Ş. İ., Akşit, S., & Açar, D. A. (2012). Kriz Sarmalında Bosna-Hersek: "Devlet Krizi". *Cycles of crises in Bosnia-Herzegovina: the 'state crisis'*, Boğaziçi Üniversitesi-TÜSİAD Dış Politika Forumu Araştırma Raporu, DPF, 1-55.

## IMPACT OF UNIVERSITY DEGREE ON THE LABOR MARKET IN SLOVAKIA

**Peter Paenak**

*Faculty of Management Comenius University in Bratislava, Slovakia  
Peter.Psenak@fm.uniba.sk*

**Urban Kovac**

*Faculty of Management Comenius University in Bratislava, Slovakia  
Urban.Kovac@fm.uniba.sk*

**Jan Kacer**

*Faculty of Management Comenius University in Bratislava, Slovakia  
Jan.Kacer@fm.uniba.sk*

**Miroslava Skypalova**

*Faculty of Management Comenius University in Bratislava, Slovakia  
Miroslava.Skypalova@fm.uniba.sk*

### ABSTRACT

*A knowledge-based economy is one of the most effective ways for a country to move forward in a strong competitive environment. Generally speaking, the development of the country includes high-quality human resources as an efficient, flexible, well-trained, professionally creative and accessible workforce. In Slovakia, over the last decade, the number of university graduates has grown to a large extent. High school students continue to pursue their studies with great expectations, hoping to find a better job and faster career growth after graduation. Unfortunately, young people tend to learn more from less demanding disciplines, pedagogy, andragogy, social work, prestigious law and medical science. Studying the more demanding sciences such as mathematics, physics, chemistry, electrical engineering is of minimal importance. Therefore, we have a large demand after such graduates on the labour market today. Currently, learning opportunities are almost unlimited. If students who want to continue studying in college have chosen the appropriate field of expertise they want to deal with in the future, they should also find the right university. What is the basis for choosing a student university if you have already found the right area for yourself? We think a possible answer to the question can be hidden in the post-university opportunities or the opportunities given by the University.*

**Keywords:** *University, education, graduates, wage, employment, students*

### 1. INTRODUCTION

A knowledge-based economy is one of the most effective ways for a country to be strong even in a competitive environment. Generally speaking, the country's development includes high-quality human resources which are effective, flexible, and appropriately skilled, professionally creative and accessible workforce. In Slovakia, over the last decade, the number of university graduates has grown to a large extent. High school students continue to pursue their studies with great expectations, hoping to find a better job and faster career growth after graduation. Currently, the learning opportunities are almost unlimited. In Slovakia there are at the time the paper was written 35 colleges, of which 23 are public and 12 private colleges. In the Slovakian context, there are no distinctions between higher education programs that concentrate mainly on practice and those focusing on higher scientific research. However, in practice it is well known that the quality of universities has an impact on public opinion in evaluating students



there, so students often take this fact into consideration when choosing an university. If students who want to continue studying in college have chosen the appropriate field of expertise they want to deal with in the future, they should also find the right university. But what is the basis for choosing a student university if you have already found the right area for yourself? We think a possible answer to the question can be hidden in the post-university opportunities.

## **2. LITERATURE REVIEW**

University graduates employability is an important issue for higher education institutions (Holmes, 2013). It "has been one of the main goals to be achieved with the creation of the European Higher Education Area (EHEA) from the very start" (Bologna Process-European Higher Education Area, 2010, Employability section, para. 1). Research has consistently shown a strong relationship between academic achievement and socioeconomic status (SES) whereby students coming from high-SES families tend to have better educated parents, have access to academically rigorous (usually private and selective) schools that prepare them to perform better academically, earn higher scores on standardized admission tests, and finish high school ready to tackle college-level academic demands (Palardy, 2008; Wyatt, Wiley, Proestler, & Camara, 2012).

### **2.1. Employability**

Employability has been defined in different ways. Some authors have conceptualized employability as the ability to gain or maintain employment (Finn, 2000; Ritchie, 2000). These definitions are tautological 'because people who are employed are defined 'employable'' (McArdle, Waters, Briscoe, & Hall, 2007, p. 248). Another problem with these definitions is that, because they are based on the outcome of being employed, they do not offer information about personal factors that strengthen employability (McArdle et al., 2007).

### **2.2. Interest in graduates**

Interest in graduates was also devoted to Humburg et al., 2014 in his research, to, which was attended by 903 employers from 9 European countries. They have studied how they affect the individual skills and level of skills the employers' interest in graduates. During the research they did an experiment at which they pre-empowered the participants hypothetical curriculum vitae.

### **2.3. Wage differences**

The second source of heterogeneity receives less attention: heterogeneous treatment effects, or the fact that university completion may result in larger wage returns for some individuals and smaller returns for others (Brand and Xie 2010; Xie et al. 2012). Chevalier, 2011 used a survey of a group of graduates in the United Kingdom, who relates to administrative data on participation in higher education. His research deals with the recruitment of fresh graduates on the labour market according to the subject of the study. Some researchers found that education expansion decreases income inequality (Ahluwalia 1974; Yu and Lu 2001); others demonstrated that education expansion augmented income inequality (Simmons and Alexander 1978).

### **2.4. Differences in satisfaction with job**

According to Granovetter (1974), 54% of those who found their jobs through contacts were very satisfied with their work compared to 30% who found their work using other ways. Similarly, a larger proportion (ten percentage points) of the former is found in the higher income group. However, these findings were only replicated by a few studies (Corcoran et al., 1980; Staiger, 1990; Wegener 1991; Coverdill, 1994; Jann, 2003), while many others could not detect a wage differential (Lin et al., 1981; Bridges and Villemez, 1986; Marsden and Hurlbert, 1988;

Preisendörfer and Voss, 1988; Lin, 1999; Mau and Kopischke, 2001). Some studies (De Graaf and Flap, 1988; Flap and Boxmann, 2001) even find a negative wage effect for social contacts. In our study we focus on graduates looking for a job through job fair portal »Profesia.sk«, the largest job fair portal in Slovakia.

### **2.5. Situation in Slovakia**

The unemployment rate of graduates under 25 years reached in Slovakia is under the EU 28 average in 2015 and 2016 (Musilová, Stachová, 2017). Total public benefits in the Slovak republic also differ between men and women, due to differences in labour market outcomes. This suggests that government have a role to play in easing the integration and participation of women in the labour market, in order to assure higher gains from the large investment of women in their education (Mikuš, 2017).

### **3. AIM OF THE RESEARCH AND HYPOTHESIS**

Based on the information above written, the question arises whether the assumptions we gave during the introduction are well-founded and right. Our research seeks to find out whether do the employers pay attention to the individual's university qualification during the selection process of their workforce. Which means if they prefer a person with a degree to another person with the same degree but from a different University. During our investigation, we focused on the field of IT, that is, the effectiveness of the positioning of employees who took their qualifications in different universities but in one of the IT departments. The surveys required for the research were conducted at different universities in Slovakia. The data is obtained from job search results of freshly trained engineers or students. With their help, we want to estimate how much the young graduate's success in the labour market is affected by the fact of which institution they have obtained their degree from. As a hypothesis, the assumptions were worded as follows:

- H1: Are the employers in Slovakia preferring a worker who has obtained a qualification at a university with a higher qualification than the one with the same degree of qualification from another inferior university.

### **4. DATA ANALYSIS**

The data of our research was provided by profesia.sk. On this site, there are people who place their biographies looking for jobs. Based on the biographies, employers can offer their free workplace to the people they choose, so the workforce does not choose their employer, but the employer chooses their employees. We used 5269 biographies for the research. Two variables were used to create the models from the database used. University - which university the person graduated from or is still studying in. This is an independent variable that is a factor variable, encoding 0 or 1 (so-called Dummy Variables). Encoding is performed automatically by the R-studio. Number of views - shows the number of clicks on biographies. This is a dependent variable in our models.

### **5. RESULTS OF THE TESTS**

Data was first analysed with simple descriptive analysis. R-Studio was use for modeling. The tables are based on the results of the R-Studio.

#### **5.1. Descriptive statistics**

Based on the results of the descriptive statistics shown in Table 1, six universities were used as input data for modeling.

Table 1: Descriptive statistics

a)		b)
University	Amount	Amount of biographies checking's
University of Economics in Bratislava (EU)	439	Min: 1.000
Other (11 universities)	895	1. quartile: 2.000
Slovak University of Technology in Bratislava (STU)	1864	Median: 4.000
Technical University of Košice (TU)	964	Mean: 6.553
Comenius University in Bratislava (UK)	396	3. quartile: 9.000
University of Žilina (ŽU)	711	Max: 64.000

There were 16 universities in the data used, but some of them appeared in a small number. Therefore, universities that appeared less than 350 times in our data were classified into the category Others. There were 11 universities in this category. Most biographies include Slovak Technical University Bratislava (STU) - 1864, almost twice more as the second Technical University of Košice behind it. Important information for our research is that only universities which have IT training in school were counted. Although we did not use the specific IT courses themselves in the analysis, but we chose the research sample based on it, there are therefore only courses related to information technology in the data. According to the selection, the results of the data used and analysed relate only to the students currently in the field of Informatics and to those seeking information-related jobs. The other variable used in modelling is the amount of biographies opening, which changes when on the website a user clicks on the biography. Table 1 (b) shows that the minimum value of clicks is 1 (in most cases) and the maximum is 64. There is a large difference between the maximum and the third quartile, which also indicates that the data set contains extreme values. We will not deal with these, as there are very few of them, so their effect on our modelling is small. If we need further clarification of the model, we will use robust regression. Figure 1 shows that the most clicks are between the interval 1 to 20, so the difference between mean and median is not generated by extreme values, but rather by values between 7 and 10.

Figure 1: Histogram of number of clicks per cv

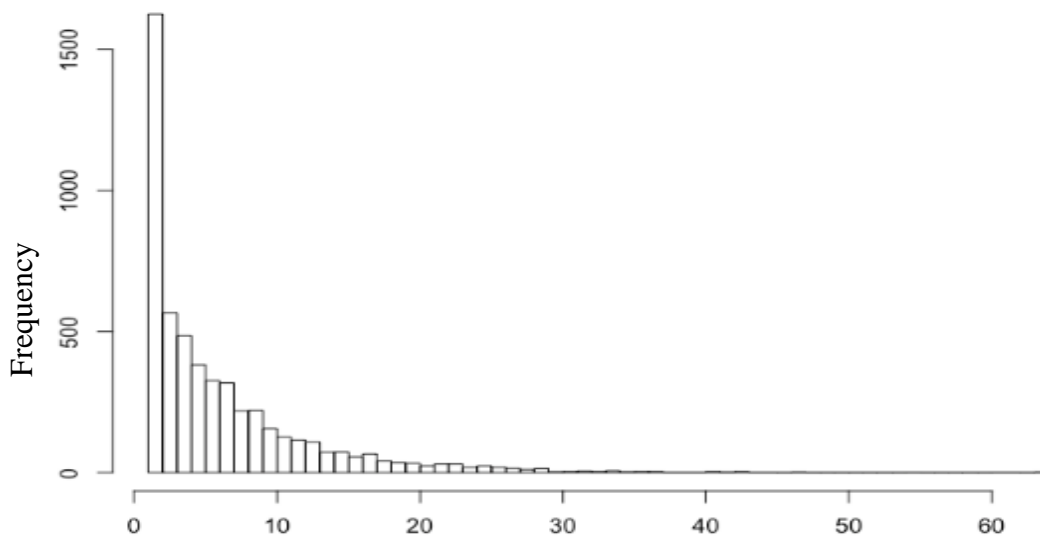

The amount of biography openings

## 5.2. Linear regression

For this decision we used the data from ARRA a rating agency for Slovak Universities. The first place from their 2015 survey was the Slovak Technical University. We used it as our benchmark value. After we have chosen the reference university, the regression calculation can follow. We split the data into a training and test set. The training set contains 80% of data, i.e. 4,214 data, the test set contains the remaining 20%, i.e. 1,052 data. We think this division is appropriate for testing the best model.

Table 2: Output from linear regression

a)	Residuals:	<i>Min</i>	<i>1. quartile</i>	<i>Median</i>	<i>3. quartil</i>	<i>Max</i>
		-6.86	-4.30	-2.05	2.07	58.07
	Coefficients:	<i>Estimate</i>	<i>Std. error</i>	<i>t-value</i>	<i>p-value</i>	
	Intercept	7.304	0.151	48.25	<2e <sup>-16</sup>	
b)	EU	-0.427	0.347	-1.23	0.22	
	Other	-1.984	0.266	-7.47	9.6e <sup>-14</sup>	
	TUKE	-1.371	0.259	-5.29	1.3e <sup>-7</sup>	
	UK	0.552	0.362	1.53	0.13	
	ZU	-1.253	0.288	-4.35	1.4e <sup>-5</sup>	
	Standard deviation	6.45, 4 209 degrees of freedom				
	R <sup>2</sup>	0.0161				
c)	Adjusted R <sup>2</sup>	0.0152				
	F statistics	17.2, on 5 and 4 209 degrees of freedom				
	p value	<2e <sup>-16</sup>				

The residuals of the model are the distances for which the real values are from the values created by the model. The ideal case is if the values are distributed symmetrically around the zero value. In our case, this is not the case since the minimum value is -6.86 and the maximum is 58.07. The median value is also negative (-2.05), which means that regression values in some cases were very far from true values, i.e. the number of openings. In the next step, the coefficients are examined. Each coefficient will be tested individually for its value. If the value is not zero it affects our model. The statistical description is as follows:

$$H_0: b_0 = 0 \text{ or } H_A: b_0 \neq 0$$

$$H_0: b_1 = 0 \text{ or } H_A: b_1 \neq 0$$

Using the coefficients in Table 2, we can find out which is important to our model. The value of the correction factor is the constant in our regression equation. The estimated value is higher than the average (7,304). In this value is our reference university, the Slovak Technical University. The standard error is quite low and the t value, just as the p value also shows that the constant is significant in the model. To achieve a simpler analysis, we will only consider p-value only. It has been a very interesting output for us that the universities with a negative number are significant in the model. This fact demonstrates that you get a lower number of views than our reference university. Only one university (Comenius University) is positive for the number of views compared to the reference university, but as the difference does not differ statistically from zero, the coefficient is not significant for our model. Also, the University of Economics is not significant either.

Based on the average number of views (6.53), we can say that the model is 98.7% different from reality and is not a real value. This shows that modeling of new values is not suitable for our simple linear regression model.

### 5.3. ANOVA test for linear regression

We have further analysed our model and we have tried to observe the significance of our entire model with the ANOVA test. The use of the ANOVA test to check the aggregate simple linear regression described above has several reasons. First, if a factor variable has more than two factors, it is difficult to interpret the summing output. Although comparing the different levels of factor variables with the reference level, it does not give the aggregate factor obtained. Table 3 shows the performance of universities as one factor and its effect on the squares sum. In addition, ANOVA enables a deeper examination of information about potential relationships between independent and dependent variables. The same link can be verified on the aggregate output by a simple t test evaluation, which, however, does not address the entire factor variables.

Table 3: ANOVA test output

<i>Coefficients</i>	<i>Dg. Of freedom</i>	<i>Sum squares</i>	<i>Mean squares</i>	<i>F value</i>	<i>P value</i>
Universities	5	3 681	736	17,2	<2e <sup>-16</sup>
Residuals	4 209	224 770	43		

Table 3 shows that the university analyses only 3,681 units out of all 228,451 squares. Furthermore, we can see that, even though the factor is entirely significant, and since it is only a simple linear regression, the whole model can be considered as significant. This significance is also shown by the p-value.

### 5.4. Robust regression

Robust regression was used as an alternative to simple linear regression. While linear regression works through the model of least squares, robust regression is based on Huber's M-estimator. We used this because our data contained extreme values. Robust regression can also be used to detect influencing parameters, so we chose the closing model of our work.

Table 4: Output of Robust regression

a)

Residuals:	<i>Min</i>	<i>1. quartile</i>	<i>Median</i>	<i>3. quartile</i>	<i>Max</i>
	-4.232	-2.375	-0.143	3.857	59.625

b)

Coefficients:	<i>Estimate</i>	<i>Std. error</i>	<i>t-value</i>	<i>p-value</i>
Intercept	5.143	0.128	40.03	<2e <sup>-16</sup>
EU	0.088	0.239	0.37	0.71
Other	-1.083	0.158	-6.84	9.0e <sup>-12</sup>
TUKE	-0.767	0.164	-4.66	3.3e <sup>-6</sup>
UK	-0.235	0.258	-0.91	0.36
ZU	-0.794	0.175	-4.52	6.3e <sup>-6</sup>

c)

Standard deviation	3.49 4209 degrees of freedom
R <sup>2</sup>	0.0142,
Adjusted R <sup>2</sup>	0.0132

In this model, the number of biography views is the dependent variable and the university is independent. Residuals are similarly working here as in the first regression, so they should be symmetrical around zero.

Although the values slightly decreased compared to simple linear regression (at a minimum of -4.23 and a maximum of 59.62), unfortunately, they are still very asymmetric. The coefficient values show that the deviation from the simple linear regression is very low. The value of the correction factor (Intercept) has dropped two points, but all the other values are approaching zero. This extreme value was achieved by lessening the weight of extreme values in the model. The same variables remained as significant as in the previous regression, although their p values rose slightly.

### 5.5. ANOVA test for robust regression

For a complete analysis of the model, we also look at the ANOVA table 5, which provides additional information to verify our model.

Table 5: ANOVA robust regression

Variable	Dg. Of freedom	Chi squared	p- value (ch test)
University	5	63,2	2,6e <sup>-12</sup>

The table results are generated on the ANOVA Chí quadrant basis. It can be seen that the results are similar to simple linear regression. This is because the robust regression is not based on the least squares, so only after observing the p value we can conclude that the variable and thus the model are significant for us.

### 5.6. Akaike information criterium values

As the end point of the research we looked at the AIC values, which show that the two models used, the robust or the simple linear regression, which is better, that is, which is more effective. The outputted values are in Table6.

Table 6: AIC values

AIC simple linear regression	34 743
AIC robust regression	34 907

The two values are very close together, so both models are appropriate for analysis. Robust regression has been a bit worse from the point of AIC so the values of simple linear regression can be better and should be taken into account for our analysis conclusion.

## 6. CONCLUSION

The models described cannot be used to predict new values, yet they contain a lot of information for us. The different values of the parameters revealed that every significant university had a lower number of views than our reference university. From this we can conclude that the fact that the jobseeker has obtained his diploma at the university has an effect on the amount of biography views. Based on this, it is possible to say that the probability of finding a job varies depending on the university. From this we can conclude that the quality of the chosen university has an effect on the freshly graduated student job options. If a student knows in advance that he / she will be more likely to work on a better position after ending the chosen university and his / her qualification has an impact on the job options, it is easier for him / her to choose an university for further study.

### LITERATURE:

1. Ahluwalia, M. 1974. "Income Inequality, Some Dimensions of the Problem." Finance and Development 11(3): 1-9.
2. Bologna Process-European Higher Education Area. (2010). *Employability*. Retrieved from: <<http://www.ehea.info/article-details.aspx?ArticleId%416>>.

3. Brand, J. E., & Xie, Y. 2010. *Who benefits most from college? Evidence for negative selection in heterogeneous economic returns to higher education*. *American Sociological Review*, 75(2), 273–302. doi:10.1177/0003122410363567.
4. Bridges, W. P. and Villemez, W. J. 1986. *Informal Hiring and Income in the Labor Market*. *American Sociological Review*, 51, 574–582.
5. Corcoran, M., Datcher, L. and Duncan, G. 1980. *Information and Influence Networks in Labor Markets*. In Duncan, G. J. and Morgan, J. N. (Eds), *Five Thousand American Families: Patterns of Economic Progress*. Ann Arbor.
6. Coverdill, J. 1994. *Personal Contacts and Post-Hire Job Outcomes*. Manuscript, Department of Sociology, University of Georgia.
7. De Graaf, N. and Flap, H. 1988. *With a Little Help from My Friends: Social Resources as an Explanation of Occupational Status and Income in West Germany, The Netherlands, and the United States*. *Social Forces*, 67, 452–472.
8. Finn, D. 2000. *From full employment to employability: A new deal for Britain's unemployed?* *International Journal of Manpower*, 21, 384–399. doi:10.1108/01437720010377693.
9. Flap, H. and Boxmann, E. 2001. *Getting Started: The Influence of Social Capital on the Start of the Occupational Career*. In Lin, N., Cook, K. S. and Burt, R. S. (Eds), *Social Capital: Theory and Re*.
10. Granovetter, M. 1974. *Getting a Job: A Study of Contacts and Careers*. Chicago and London: University of Chicago Press.
11. Holmes, L. 2013. *Competing perspectives on graduate employability: Possession, position or process?* *Studies in Higher Education*, 38, 538–554. doi:10.1080/03075079.2011.587140.
12. HUMBURG, M. VAN DER VELDEN, R. 2014. *Skills and the graduate recruitment process: Evidence from two discrete choice experiments*. Available from: <<https://EconPapers.repec.org/RePEc:unm:umaror:2014002>>. ROA Research Memorandum. Maastricht University, Research Centre for Education and the Labour Market (ROA).
13. CHEVALIER, A. 2011. *Subject choice and earnings of UK graduates*. *Economics of Education Review*. Vol. 30, č. 6, s. 1187–1201. ISSN 0272-7757. Available from: <DOI: 10.1016/j.econedurev.2011.04.007>. Special Issue: Economic Returns to Education.
14. Jann, B. 2003. *Old Boy Network. Militärdienst und ziviler Berufserfolg in der Schweiz*. *Zeitschrift für Soziologie*, 32, 139–155.
15. Lin, N. 1999. *Social Networks and Status Attainment*. *Annual Review of Sociology*, 25, 467–487.
16. Lin, N., Vaughn, J. C. and Ensel, W. M. 1981. *Social Resources and Occupational Status Attainment*. *Social Forces*, 59, 1163–1181.
17. Marsden, P. and Hurlbert, J. 1988. *Social Resources and Mobility Outcomes: A Replication and Extension*. *Social Forces*, 66, 1038–1059.
18. Mau, W., Ch. and Kopischke, A. 2001. *Job Search Methods, Job Search Outcomes, and Job Satisfaction of College Graduates: A Comparison of Race and Sex*. *Journal of Employment Counselling*, 38, 141–149.
19. McArdle, S., Waters, L., Briscoe, J. P., & Hall, D. T. 2007. *Employability during unemployment: Adaptability, career identity and human and social capital*. *Journal of Vocational Behavior*, 71, 247–264. doi:10.1016/j.jvb.2007.06.003.
20. Mikuš, J. 2017. *Inkluzivita podnikania v regiónoch Slovenska*. In: *Finančný manažér*. Vol. 17, No. 3 (2017), p. 18-26.
21. Musilová, M., Stachová, P. 2017. *Unemployment of secondary education graduates in Slovakia*. In: *Vision 2020: sustainable economic development, innovation management, and global growth*. p. 5355-5360. Norristown: IBIMA.

22. Palardy, G. J. 2008. *Differential school effects among low, middle, and high social class composition schools: A multiple group, multilevel latent growth curve analysis*. *School Effectiveness and School Improvement*, 19, 21–49. doi:10.1080/09243450801936845.
23. Preisendörfer, P. and Voss, Th. 1988. *Arbeitsmarkt und soziale Netzwerke*. Die Bedeutung sozialer Kontakte beim Zugang zu Arbeitsplätzen. *Soziale Welt*, 39, 104–119.
24. Ritchie, J. 2000. *New deal for young people: Participants' perspectives*. *Policy Studies*, 21, 301–312. doi:10.1080/713691372.
25. Simmons, J., and L. Alexander. 1978. "The Determinants of School Achievement in Developing Countries: A Review of Research." *Economic Development and Cultural Change* 26 (2): 341–358.
26. Staiger, D. 1990. *The Effect of Connections on the Wages and Mobility of Young Workers*. Cambridge, MA: MIT Press.
27. Wegener, B. 1991. *Job Mobility and Social Ties: Social Resources, Prior Job, and Status Attainment*. *American Sociological Review*, 56, 60–71.
28. Wyatt, J. N., Wiley, A., Proestler, N., & Camara, W. J. 2012. *The development of an index of academic rigor for college readiness*. Washington, DC: College Board. Available from: <<https://research.collegeboard.org/sites/default/files/publications/2012/7/researchreport2011-11-development-index-academic-rigor-college-success.pdf>>.
29. Xie, Y., Brand, J. E., & Jann, B. 2012. *Estimating heterogeneous treatment effects with observational data*. *Sociological Methodology*, 42(1), 314–347.
30. Yu, H. D., and G. S. Lu. 2001. "Influence of China's Higher Education Expansion on the Income Distribution." *Education and Economy*, no. 1: 6–11.



## WEALTH OR HAPPINESS OF THE EUROPEAN UNION– THE DILEMMA OF THE NORMATIVE ECONOMICS

**Tomasz Studzieniecki**  
Gdynia Maritime University, Poland  
tomaszstudzieniecki@wp.pl

### ABSTRACT

*This paper undertakes the issue of the relation between the wealth of the nations and the happiness of their citizens. The notion of happiness and the ways of its measurement has long been left on the margin of the economic science. Determining the definition of happiness has not been the only problem, but the methods of measuring it as well. A research in literature on wealth and happiness has been carried out for the sake of this paper. The specific nature of economics as part of humanities has been discussed proving that it is the challenge for economics to study both wealth and happiness. The specific nature of Positive and Normative Economics has been compared which resulted in the conclusion that it is the task of Normative Economics to shape the reality in order to provide wellbeing and happiness to ordinary people. The idea of "good economics" has been exposed to be used to focus on man and their needs. Further, empirical study of the level of happiness and wealth has been carried out in the European Union states. The level of wealth was measured with the use of the most popular tool, i.e. Gross National Product per capita. For this purpose, the data of the World Bank was used. Also the level of happiness of the UE citizens has been measured. The HPI- Happiness Index Planet was used, developed by experts of New Economic Foundation. This tool involves such elements as wellbeing, life expectancy, inequality of outcomes, ecological footprint. The findings showed a moderate correlation between happiness and wealth. They proved a significant differentiation between particular countries of the European Union showing that the countries of the so called Central-Eastern Europe make up the group of poor and least happy ones. The Scandinavian countries and Holland proved the reverse. An interesting situation was noted in Luxembourg which is regarded as the richest country in the European Union, where the results showed the worst coefficient of happiness. The Author has drawn the conclusion that the happiest countries cannot be the poorest. This means that the European Union faces a challenge and within social and political policies is supposed to provide the nations not only with wealth but happiness as well.*

**Keywords:** *wealth, happiness, well-being, economics, European Union*

### 1. INTRODUCTION

The humanising process within economics exposed man and their needs which became the focus of scientific research. The necessity of a wider and more interdisciplinary approach to economics occurred. The Normative Economics faces the answer not only to the question "how to become rich" but "how to become happy" as well. The comparison of wealth and happiness is a complex task in terms of methodology for creating the definition of happiness and its quantification makes a difficulty. The scientific research not always shows the correlation between happiness and wealth. Do we notice this situation also in the European Union? Are the citizens of rich countries happy as well? The answers to these questions call for a selection of adequate measuring tools and carrying out empirical studies.

### 2. ECONOMICS AS SCIENCE

Economics is a fairly new science, nevertheless, very differentiated. Three trends can be distinguished within it: the mathematical, the social and the historical ones (Beksiak, 2014, p. 1). Majority of economists claim economics to be social knowledge (Włudyka, Smaga 2012, p.

16) and contest its status of natural science (Cholewa, 2012, p. 159). In practical terms, the distinction between the social science and natural or mathematical science is very blurred. Economics is in close connection with other social disciplines (such as psychology and sociology) and derives from their achievements (Księżyk, 2012, p. 60). In a broader sense, economics reflects on managing people's lives (Lange, 1973, p. 885; Michalski, 2015, p. 331). This science analyses the actions of societies in their everyday lives (Marshal, 1920, p. 6), studies "how do people cope with rarity" (Kamershen, McKenzie, Nardinelli, 1991, p. 7). It guides on how to manage to make the management rational (Księżyk, 2012, p. 56), in other words: how to make optimal use of the limited resources in terms of production, distribution, exchange and consumption (Bannock, Baxter, Davis, 1987, p. 128). The theory of economics puts forward the solutions for economic entities allowing for maximising targets or reducing the expenses. Economics explains the process of "good economy" development (Bałtowski, 2016, p. 17) and building up the well-being (Frank, 2007, p. 44; Horodecka, 2011, p. 5; Gorynia, 2017, p. 15). Economics tries to master the methods and tools for "showing, diagnosing and forecasting all this what happens in every place where people manage their households" (Michalski, 2015, p. 320).

### 3. CHALLENGES OF NORMATIVE ECONOMICS

The contemporary discussion over the methodological homogeneity or diversity of economics focuses on the question whether economics should be Positive science dealing with the world as it is or Normative science using evaluating opinions allowing for giving an answer to the question what the world should be like (Kamershen, McKenzie, Nardinelli, 1991, p. 15-17). Comparing the assumptions of both types of economics (tab.1) it is clear that Positive Economics is of a theory cognitive nature while the Normative Economics is of a more applicable type.

*Table 1: Comparison of Positive and Normative Economics*

*(Author's own survey following: Księżyk, 2012, p. 62; Nasilowski, 2005, p. 24; Bałtowski, 2016, p. 17; Gorynia, 2017, p. 17; Włudyka, Smaga, 2012, p. 17; Kamershen, McKenzie, Nardinelli, 1991, pp. 15-17; Fiedor, 2013, pp. 101-118; Czarny, 2013, pp. 91-100; Dzionek-Kozłowska, 2013, pp. 335-344; Cholewa, 2012, p. 158).*

Criterion	Normative Economics	Positive Economics
The Objective	Presentation of the real life as it should be	Presentation of the real life as it should be
The target	Creating tools adjusted to the expressed beliefs	Creating universal tools and methods of economic analysis
Nature	Of demand character	Descriptive
Attitude to evaluative opinions	Making use of evaluative opinions	Avoiding evaluative opinions
Value judgement of the correctness of managing processes	A subjective judgement of the management process correctness	Neutral judgement of the management process correctness
Working towards a solution	Prevailing institutional solutions	Prevailing individual solutions
Ethics	Possible reference to ethics	No reference to ethics
Ideologization	No protection against ideologization	Protection against ideologization in place.
Deriving from other approaches' findings	Deriving from Positive Economics achievements	Reserve to the Normative Economics achievements

Opinions can be found among economists that it is only the Positive Economics which makes real science (Włudyka, Smaga, 2012, p. 15). However, given an increase in the interest in the Normative Economics (Gorynia, 2017, p. 17; Kołodko, 2016, p. 200 an opinion may be expressed that both types of economics are equal and necessary (Bałtowski, 2016, p. 17). Disputes over the hierarchy of these both trends are said to be unnecessary and even void (Czarny, 2013, p. 980. Fiedor put forward a suggestion worth looking at that rather than distinguishing between Positive Economics and Normative Economics, we should talk about

Positive Economics (or simply Economics) and Economic Policy. The main-stream Economics is drifting away from its study objective – the society and individuals (Cholewa, 2012, p. 1660). There start to occur suggestions to develop “good economics”. For Sedlaczek (2012, p. 7), good economics is such knowledge the results of which are good for the society. Economics should serve as a guideline for “the change of the world for the better” (Kołodko, 2013, p. 25). Economic study should be carried out in the context of a specific system of values in a society (Michalski, 2015, p. 309). It is believed (Kołodko, 2014, p. 161; Jegorow, 2016, p. 130) that it is this imperative that will pave the way for the contemporary theory of economics. Economics must tackle the complexity of conditions the economic entities are subject to, along with the co-dependence of purely economic, social, cultural, ethical and even religious or spiritual dominants (Fiedor, 2013, p. 108; Grobelna, Sidorkiewicz, Tokarz-Kocik, 2016, p. 281). This involves an interdisciplinary mode of economic research meant as both cooperation between particular disciplines making up economic science and cooperation with the knowledge of quite different origin (Gorynia, Kowalski, 2013, p. 468).

#### **4. WEALTH AND HAPPINESS IN THE THEORY OF ECONOMICS**

The classical economists have always been focusing on life managing as an action promising success to an individual. The concept of homo oeconomicus is the one they have adopted most frequently, according to which the purpose of man is expressed by maximising the usefulness and profit. It has only been recently that economists start to take to happiness. It used to be left aside of empirical knowledge for a long time. Until late 19c. only philosophers were writing about happiness. It was not until 1960s that psychologists and sociologists started getting interested in the subject as part of a more general construct – the psychic well-being and quality of life (Czapiński, 2012, p.p. 51-88). Following WWII the Economics of Happiness started to develop rapidly. The Economics of Happiness is an approach assessing welfare which combines the techniques typically used by economists with those more commonly used by psychologists. It relies on surveys of the reported well-being of hundreds of thousands of individuals across countries and continents (Graham, 2005, pp. 201-231). In order to understand the Economics of Wealth, one has to go through the achievements of economics in 18c. when A. Smith (1776), a pioneer in the history of economics, analysed the nature of nations’ wealth. He indicated the components of wealth claiming that the distribution of work, technical capital and human skills were the factors making up the nations’ wealth and free competition was the fundamental mechanism of the economic growth. In the context of Smith’s theory, the creation of the measuring tool of wealth and measuring method became a challenge. Until today, GDP and GDP per capita have been the basic measure of development and well-being (Zaremba, 2016, p. 323-331). But the GDP does not mean a better life for everyone, particularly in the countries that are wealthy already. It does not reflect inequalities in material conditions among people in a country. It does not properly value the things that really matter to people, such as social relations, health or the way they spend their free time (Happy Index Planet, 2016, p. 2). Undoubtedly, wealth may be regarded only as the means of achieving happiness. However, determining the definition of happiness poses a difficulty. Polish philosopher, Władysław Tatarkiewicz (1962, pp. 15-29) distinguished four, most common notions of happiness. Two of them have different meanings in everyday speech: ‘luck’ and ‘joyful life’ while the other two occur in the philosophical language: the notion of happiness as Eudaimonia (the greatest measure of assets available for man) and well-grounded, complete and long-lasting satisfaction of life as a whole. The attempts to study happiness in an empirical way derive from the definition describing it as some sort of enjoyment of life or positive emotions or even personal or social and cultural values (Kanasz, 2015, p. 21). The 21st century has seen an increase within economics in the phenomenon of happiness. In 2006, a team of British experts from the New Economic Foundation developed a measuring tool to qualify the well-being of the citizens in

different states. It combines four elements (tab. 2) to show how efficiently the residents of particular countries are using the environmental resources to live long, happy lives (Happy Index Planet, 2016, p. 1).

*Table 2: The structure of Happy Planet Index (Happy Index Planet, 2016, p. 1).*

No.	Component	Component objective
1.	Wellbeing	How satisfied the residents of each country feel with life overall, on a scale from zero to ten, based on data collected as part of the Gallup World Poll.
2.	Life expectancy	The average number of years a person is expected to live in each country based on data collected by the United Nations Inequality.
3.	Inequality of outcomes	The inequalities between people within a country in terms of how long they live, and how happy they feel, based on the distribution in each country's life expectancy and wellbeing data.
4.	Ecological Footprint	The average impact that each resident of a country places on the environment, based on data prepared by the Global Footprint Network.

The HIP measuring tool is the quotient where the dividend is made up of the product of the first three elements while the fourth element is the divisor. The measuring tool constructed in this way exposes the "environmental factor" (Przybyłowski, 2018, p. 195). By measuring the quantity of natural resources used by particular countries to arrive at those outcomes, the Happy Planet Index shows where in the world the well-being is achieved sustainably (Happy Index Planet, 2016, p. 1).

## 5. THE EUROPEAN UNION IN THE WEALTH AND HAPPINES CONTEXT

The analyses of the wealth level in the EU countries usually use the GDP per capita tool. In so doing, vast differences between the countries of central-and-Eastern Europe and Western Europe are depicted. The year 2017 (fig. 1) showed the worst situation in Bulgaria (USD 8031) contrasted to the best in Luxembourg (USD 104 103). This means that an average statistical citizen of Luxembourg was nearly 123 times richer than a respective citizen in Bulgaria (The World Bank, 2018).



*Figure 1: The Gross Domestic Product per capita in the European Union countries in 2017, thousands of USD (author's own survey based on: The World Bank, 2018).*

The analysis of the well-being level using the Happy Index Planet indicator (2016) showed (fig. 2) that the richest EU country like Luxembourg is in a worse result (13.2). Subsequent unfavorable results were the Baltic Republics and Bulgaria. The best results were in Spain (36), the Netherlands (35, 3) and Denmark (32.7). It is worth noting that Croatia (30.2) took the best position among the countries of Central and Eastern Europe.



*Figure 2: World Happiness Index in the EU countries in 2016  
(author's own survey based on The Happy Planet Index, 2016).*

The comparative analysis of GDP per capita and HIP indexes shows (fig. 3) that wealth only partially translates to happiness. This refers to the Scandinavian countries, Denmark in the first place, who has the highest position in both rankings. Also the Dutch are both rich and happy. The countries of Central-Eastern Europe are at the other end; they are not only the poorest but least happy as well.

*Figure following on the next page*

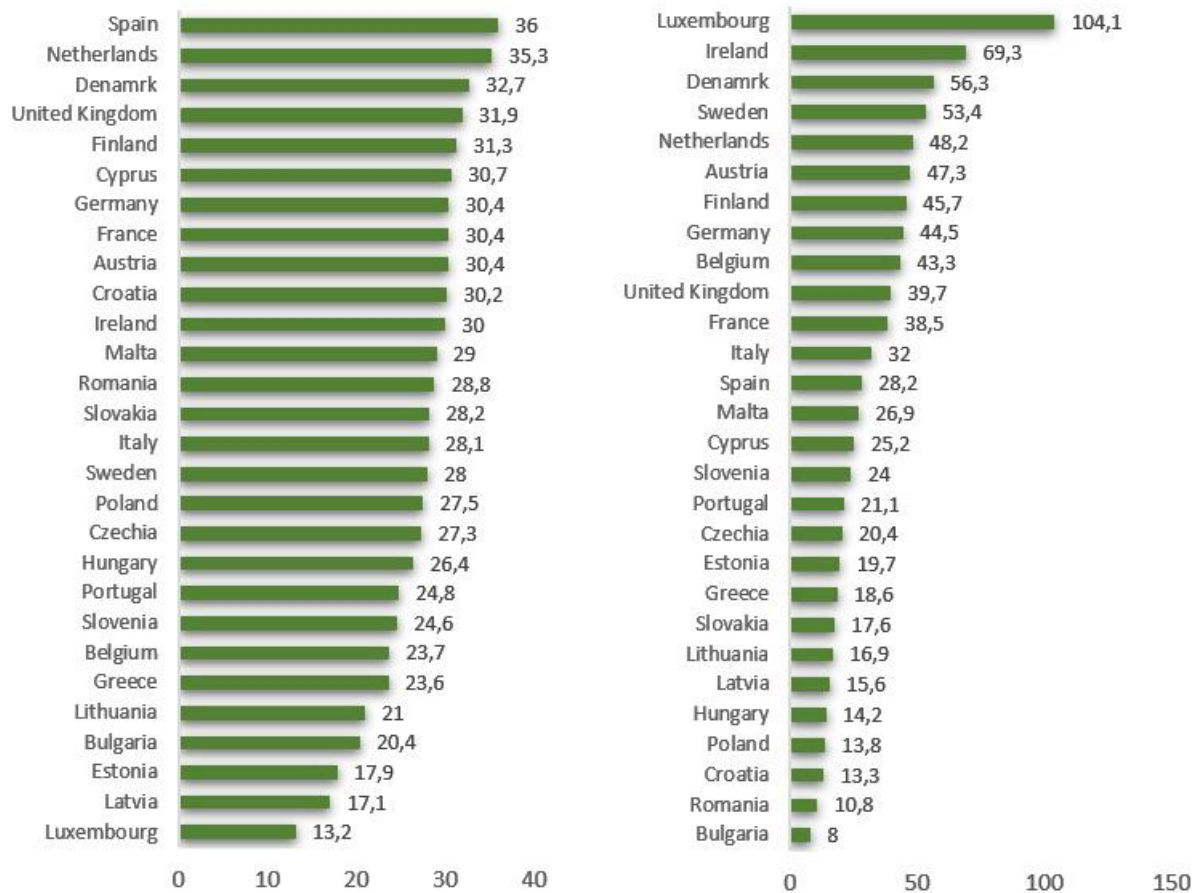

Figure 3: The comparison of the European Union countries in terms of GDP per capita and HIP Index (author's own survey based on *The Happy Planet Index, 2016*; *The World Bank, 2018*).

It must be mentioned here that the countries making up the first top ten in terms of happiness, are also top fifteen richest ones. This means that wealth makes the necessary yet insufficient condition to reach happiness. In the context of European integration the reduction of differences in the wealth and well-being levels must be addressed. For this reason, the European Union “must avoid the rhetoric and instead explain in plain language how it adds value to its citizens’ lives” (Project Europe 2030, 2010).

## 6. CONCLUSION

Making use of Positive Economics achievements, the Normative Economics is supposed to answer not only the question asking how it is currently, but how it should be as well. Thus it will become the foundation of economic policy. Polish economist Grzegorz Kołodko is right saying that Economics must be a signpost for the world to change for the better. For this reason the issue of happiness must not only be subject to a scientific study but also be reflected in the economic policies. This refers also to the European Union, heavily differentiated both in terms of economic development and the feeling of happiness experienced by its citizens. In order to be able to evaluate the wealth (the economy standing), it is worthwhile to have a look at the set of indexes reaching beyond the GDP per capita. The result obtained gives a more complete image which additionally not only mirrors the current state but the growth potential as well. It is also advisable to make effort and try to master the happiness index (well-being). This will help in shaping up and executing the policy which aims at meeting the social expectations more fully. It must not be forgotten that there is no single happiness measuring tool.

This results from the complexity of the notion of happiness and different conditions in which it is achieved. The HPI measuring tool used for this survey is one of many therefore the results of the comparative analysis, applied in this paper, may be regarded as disputable. The case of Luxembourg proves that the richest European society is the least happy. At the same time, attention must be paid to the fact that the happiest countries are not the poorest ones. Thus, the European Union faces the challenge to provide its nations not only with wealth but also with happiness.

#### LITERATURE:

1. Bałtowski, M. (2016). Ekonomia jako nauka porównawcza a problem sądów wartościujących. *Studia Ekonomiczne. Zeszyty Naukowe Uniwersytetu Ekonomicznego w Katowicach* (No 259, pp. 9-18). Katowice: Uniwersytet Ekonomiczny w Katowicach.
2. Bannock, G., Baxter, R., Davis, E. (1987). *Dictionary of Economics*. London: The Penguin.
3. Beksiak, J. (2014). *Ekonomia. Kurs podstawowy*. Warszawa: Wydawnictwo CH Beck.
4. Cholewa, Ł. (2012). Ekonomia jako nauka społeczna spojrzenie krytyczne. *Problemy Zarządzania, Finansów i Marketingu* (No. 27, pp. 157-167). Szczecin: Uniwersytet Szczeciński.
5. Czapiński, J. (2012). Ekonomia szczęścia i psychologia bogactwa. *Nauka* (pp. 51-88). Warszawa: Polska Akademia Nauk.
6. Czarny, B. (2013). Co to znaczy w ekonomii „sąd wartościujący” i „ekonomia wolna od sądów wartościujących”? *Studia Ekonomiczne*, (No 1 (LXXVI), pp. 90-100). Katowice: Uniwersytet Ekonomiczny w Katowicach.
7. Dzionek-Kozłowska, J. (2013). Ekonomia jako nauka pozytywna. Refleksje na marginesie „Ekonomii dobra i zła”. *Annales. Etyka w życiu gospodarczym* (vol. 16, pp. 335-344). Łódź: Uniwersytet Łódzki.
8. Fiedor, B. (2013). Uwagi o potrzebie równowagi metodologicznej w ekonomii. *Studia Ekonomiczne* (No 1 (LXXVI) pp. 101-118). Katowice: Uniwersytet Ekonomiczny w Katowicach.
9. Frank, R. (2007). *Mikroekonomia. Jakiej jeszcze nie było*. Gdańsk: Gdańskie Wydawnictwo Psychologiczne.
10. Gorynia, M. (2017). Nauki ekonomiczne wobec globalnych i regionalnych wyzwań drugiej dekady XXI wieku. In: C. Zajac (ed.) *Nauki ekonomiczne w XXI wieku – dylematy, wyzwania, perspektywy* (pp. 11-32). Wrocław: Wydawnictwo Uniwersytetu Ekonomicznego we Wrocławiu.
11. Gorynia, M., Kowalski, T. (2013). Nauki ekonomiczne i ich klasyfikacja a wyzwania współczesnej gospodarki. *Ekonomista* (No 4, pp. 457-474). Warszawa: Ekonomista.
12. Graham, C. (2005). Insights on Development from the Economics of Happiness. *The World Bank Research Observer* (Vol. 20, No. 2, pp. 201-231). Oxford: Oxford University Press.
13. Grobelna, A., Sidorkiewicz, M., Tokarz-Kocik, A. (2016). Job satisfaction among hotel employees: analyzing selected antecedents and job outcomes. a case study from Poland. *Argumenta Oeconomica* (No 2 (37), pp. 281-310). Wrocław: Wrocław University of Economics.
14. Horodecka, A. (2011) Problem definiowania dobrobytu i wartości w ekonomii i jego znaczenie dla polityki gospodarczej. *Prace i Materiały Instytutu Rozwoju Gospodarczego SGH* (pp. 5-47). Warszawa: SGH.
15. Jęgorow, D. (2016). Ekonomia próżni wyzwania rozwojowe. *Prace Naukowe Uniwersytetu Ekonomicznego we Wrocławiu* (NO 439, pp. 126-133). Wrocław: Uniwersytet Ekonomiczny we Wrocławiu.
16. Kamershen, D., McKenzie, R., Nardinelli, C. (1991). *Ekonomia*. Fundacja Gospodarcza Gdańsk: NSZZ Solidarność.

17. Kamiński, S. (1992). *Nauka i metoda. Pojęcie i klasyfikacja nauk*. Lublin: Towarzystwo Naukowe KUL.
18. Kanasz, T. (2015). *Uwarunkowania szczęścia*. Warszawa: Wydawnictwo Akademii Pedagogiki Specjalnej.
19. Kołodko, G. (2013). *Dokąd zmierza świat. Ekonomia polityczna przyszłości*. Warszawa: Prószyński i S-ka.
20. Kołodko, G. (2014). Nowy Pragmatyzm, czyli ekonomia i polityka dla przyszłości. *Ekonomista* (No. 3, pp. 160-180). Warszawa: Ekonomista.
21. Księżyk, M. (2012). *Ekonomia Podejście historyczne i perspektywne*. Kraków: Krakowskie Towarzystwo Edukacyjne sp. z o.o. – Oficyna Wydawnicza AFM.
22. Lange, O. (1973). *Ekonomia polityczna*. Warszawa: Państwowe Wydawnictwo Ekonomiczne.
23. Marshall, A. (1920). *Principles of Economics*. London: Macmillan and Co.
24. Michalski, M. (2015). Ekonomia dobra czy zła? Ekonomiczno- -gospodarcze paradoksy współczesności. *Zeszyty Naukowe Centrum Badań im. Edyty Stein* (No 13/14, pp. 309-323). Poznań: Centrum Badań im. Edyty Stein.
25. Nasiłowski, M. (2005). *System rynkowy: podstawy mikro- i makroekonomii*. Warszawa: Wydawnictwo Key Text.
26. Project Europe 2030 (2010). *Project Europe 2030. Challenges and Opportunities A report to the European Council by the Reflection Group on the Future of the EU 2030*. Luxembourg: Publications Office of the European Union.
27. Przybyłowski, A. (2018). Sustainable urban mobility planning: Gdynia city case study. *Ekonomia i Prawo – Economics and Law* (Vol. 17/2, pp. 195-209). Toruń: Uniwersytet Mikołaja Kopernika.
28. Sadowski, A., Szydlik, A. (2016). Poznanie naukowe i kanony nauki. *Optimum. Studia Ekonomiczne* (No 2, pp. 55-68). Białystok: Uniwersytet w Białymstoku.
29. Sedlaczek, T. (2012). *Ekonomia dobra i zła. w poszukiwaniu istoty od Gilgamesza do Wall Street*. Wydawnictwo Emka, Warszawa.
30. The Happy Planet Index (2016). London: New Economics Foundation.
31. The World Bank (2018). *GDP per capita (current USD)*. Retrieved 23.11.2018 from <https://data.worldbank.org/indicator/NY.GDP.PCAP.CD>.
32. Tatarkiewicz, W. (1962), *O szczęściu*. Warszawa: PWN.
33. Włudyka, T., Smaga, M. (2012). *Definicja ekonomii*. in: T. Włudyka, M. Smaga (eds.) *Instytucje gospodarki rynkowej* (pp. 16-17. Warszawa: Lex a Wolters Kluwer Business.
34. Zaremba, M. (2016). Dobrobyt społeczny – problemy metodologiczne i definicyjne. *Zeszyty Naukowe Polskiego Towarzystwa Ekonomicznego w Zielonej Górze* (pp. 323-331). Zielona Góra: Polskie Towarzystwo Ekonomiczne.



## SUSTAINABLE DEVELOPMENT OF AGRICULTURAL PRODUCTION IN BALTIC STATES

**Zofia Koloszko-Chomentowska**  
*Bialystok University of Technology, Poland*  
*z.koloszko@pb.edu.pl*

### **ABSTRACT**

*Agriculture in EU member states is supported and protected under the Common Agricultural Policy (CAP). One of the more important objectives of this policy is to ensure sustainable development of rural areas by providing the appropriate quality of life for their populations and fully utilizing factors of production in agriculture. A particular role is attributed to agri-environmental programs including organic production. Organic farms play an important role in local development by providing high quality products and environmental protection. The common agricultural policy is oriented towards supporting the development of sustainable production regardless of the farming method. This is in line with the principles of sustainable development. This is particularly significant in the case of new EU member states, in which there is high underdevelopment. The aim of the work is to assess the activities supporting the sustainable development of agricultural production in Estonia, Lithuania, Latvia and Poland in 2013-2015. Selected elements of financial analysis were applied. Research indicates that the idea of sustainable development is implemented at the level of farms. In all countries, farms benefited from subsidies for farming under unfavorable conditions (LFA) and agri-environmental programs. Public funds have contributed to the improvement of the economic situation of farms.*

**Keywords:** *agricultural production, Baltic States, development, rural areas*

### **1. INTRODUCTION**

Achievement of sustainable development of agriculture and rural areas is an integral part of the general concept of sustainable development of a country, knowledge-based development. Such a system of management requires knowledge on the subject of the codependencies between human economic activity and the environment. Those working with the environment are deadline with living nature, which has a significant impact on other means of production. This is also significant from the perspective of development of the entire economy, since care for sustainable development of agriculture contributes to socioeconomic changes in rural areas and full realization of the economic potential of such areas (Mykhailovych Gazuda 2013). Management of agricultural development takes place on two, strictly linked levels. The first is agricultural policy, mainly including implementation of agricultural support programmes financed by public funds (from the EU budget and partially from the national budget). Reception of public subsidies is dependent on a farmer's adherence to the principles of environmental protection. An agricultural, environmental and climate measure is implemented in RDP (Rural Development Programme) 2014-2020. The essence of this measure is to promote practices serving for protection of all elements of nature. It is a continuation of measures taken within the framework of the Agri-environment programme of RDP 2007-2013. Funds received within the framework of the RDP increase income and stimulate demand for investment and consumption. The second level is implementation of measures at the level of an individual farm, and these measures arise from the development policy accepted at the national level. Farm owners are responsible for implementing these measures. It is they who bear full responsibility for manufacturing high-quality goods and applying technologies in adherence to the principles of protection of natural resources. Organic farming exhibits special relationships with sustainable development.

This method of farming is the closest to the philosophy of sustainable development. There are many premises speaking in favour of the growth of organic farming. Above all, it provided high-quality products, which has a positive effect on human health. This method of farming contributes to preservation of the biodiversity, resilience and integrity of ecosystems. Thus, organic farming also plays an important social role, as it contributes to the development of rural areas by increasing employment and connecting producers to consumers (Lobley et al. 2009, O'Hara and Parsons 2013, Zimnoch 2018). For several years, growth of the number of organic farms has been observed in all EU member states. In 2015, over 271.5 thousand agricultural producers conducted organic farming activity in EU countries, including 22.2 thousand in Poland, and the surface area of organic crops amounted to 11.1 million hectares (Raport..., 2017). The common agricultural policy is oriented towards supporting the development of sustainable production regardless of the farming method. Funds for measures related to environmental protection are directed to agricultural holdings. The Rural Development Programme 2014-2020 covers the following programmes: agri-enviro-climatic measures, organic farming, payments to less favoured areas (LFAs) and investments in the development of forested areas. The sustainable model of agricultural production is promoted in this way. This is particularly significant in the case of new EU member states, where there is high underdevelopment. Studies conducted until now show that CAP funds improved the production and economic results of agricultural holdings. They also contributed to improving the condition of the natural environment, and thus, to improving living conditions in rural areas. The goal of this paper is to assess measures intended for sustainable development of agricultural production in the Baltic states: Estonia, Latvia, Lithuania and Poland.

## 2. METHODOLOGY

The research problem was elaborated based on the literature and data found in the FADN system. Data from farms are publicly available (European ..., 2015). The scope of analysis covers the years 2013-2015. This allows for assessment of changes over time, despite the fact that the time period is not long. Use of funds within the framework of Rural Development Programme 2014-2020 was considered to be a measure linked to sustainable development, and these funds are linked to organic production, farming in less favoured areas as well as to agrienvironmental measures. Based on available data, the utilization of funds under these programs by agricultural holdings in Estonia, Latvia, Lithuania and Poland was assessed. Selected methods of financial analysis were also applied (Gabrusewicz, 2007). The economic situation of farms was assessed based on net value added (SE425) and income from a family-owned farm per unit of labour in the family (SE430).

## 3. RESULTS

Table 1 presents selected characteristics of farms in Baltic states from the perspective of relationships with sustainable production. The analysis accounts for the surface area of farmland, the surface area of farmland in organic farms and livestock density. The presented data show that the mean surface area of farmland per farm decreased in all states during the years 2013-2015. The greatest changes occurred in Estonia (reduction by 9.76 ha), and in other countries, changes ranged from 0.36 ha to 4.90 ha. The situation is different with regard to organic farms. In Estonia and Latvia, the surface area of organic farms is smaller than that of traditional farms, whereas in Lithuania and Poland, organic farms are larger than conventional farms. Farm size is an important determinant of economic results. Studies conducted in Poland show that organic farms with a surface area above 20 ha achieved higher economic results (Koloszko-Chomentowska 2015).

*Table 1: Selected characteristic of farms in Estonia, Lithuania, Latvia, Poland (FADN data)*

Specification	Estonia	Lithuania	Latvia	Poland
2013				
Utilised agricultural area (ha)	136.95	48.55	69.09	18.81
Organic utilised agricultural area (ha)	97.95	64.54	53.48	25.18
Stocking density (LU·ha <sup>-1</sup> )	0.64	0.58	0.53	1.54
2014				
Utilised agricultural area (ha)	128.72	47.48	65.07	18.40
Organic utilised agricultural area (ha)	97.46	63.93	56,57	24.73
Stocking density (LU·ha <sup>-1</sup> )	0.64	0.63	0.53	1.62
2015				
Utilised agricultural area (ha)	127.19	46.33	64.19	18.46
Organic utilised agricultural area (ha)	95.65	79.93	63.73	26.07
Stocking density (LU·ha <sup>-1</sup> )	0.62	0.62	0.53	1.56

Animal production is an important factor in assessment of the sustainability of agricultural production. Organization of livestock production is assessed from the perspective of use of produced manure. The number of animals on a holding and their stocking density are both important. In both cases, mean stocking density in holdings did not pose a threat to the natural environment because it did not exceed the maximum level of 1.5 LU·ha<sup>-1</sup> (Duer et al. 2002). The presented data show that farms in Estonia, Lithuania and Latvia have a small number of animals. Not so in the case of Polish farms, where there is a large share of animal production in the production structure, resulting in high livestock density. However farms are more diverse in terms of herd size, so it can be surmised that environmental hazards may be present at the level of a single farm. In the assessment of measures promoting sustainable production, the utilization of funds from the Rural Development Programme, financed under the EU budget, was taken into account. Data indicate that farms in Poland received the most funds. During the years 2013-2015, these funds amounted to EUR 914.19 per 1 ha of farmland (tab.2). Estonian farms received the least funds – 568.21 EUR·ha<sup>-1</sup>. Environmental subsidies were dominant in the structure of subsidies in Estonia. In the case of Lithuanian farms, subsidies for Less Favoured Areas and other programmes supporting development of rural areas were most substantial during the years 2013-2014. The latter included, among others, subsidies for afforestation and ecological stability of forests. According to studies, funds from RDP directed to rural areas in the years 2007-2013 contributed to growth of GDP by 0.61% on average in current prices and 0.32% in fixed prices (Zaleski, 2015).

*Table following on the next page*

Table 2: Subsidies for measures serving for sustainable production (own calculation based on FADN data)

Specification	Estonia	Lithuania	Latvia	Poland
2013				
Total subsidies excluding on investment (EUR·ha <sup>-1</sup> )	197.37	186.93	195.86	316.96
Environmental subsidies (EUR·ha <sup>-1</sup> )	59.61	4.49	28.47	30.89
LFA subsidies (EUR·ha <sup>-1</sup> )	10.04	21.28	3.66	2.39
Other rural development payments (EUR·ha <sup>-1</sup> )	1.13	21.28	3.66	2.39
2014				
Total subsidies excluding on investment (EUR·ha <sup>-1</sup> )	182.78	193.64	222.31	316.14
Environmental subsidies (EUR·ha <sup>-1</sup> )	55.50	1.62	5.56	28.97
LFA subsidies (EUR·ha <sup>-1</sup> )	9.18	23.19	28.52	27.74
Other rural development payments (EUR·ha <sup>-1</sup> )	5.55	23.00	25.52	1.96
2015				
Total subsidies excluding on investment (EUR·ha <sup>-1</sup> )	188.06	210.42	232.54	281.09
Environmental subsidies (EUR·ha <sup>-1</sup> )	51.69	20.29	28.66	2.71
LFA subsidies (EUR·ha <sup>-1</sup> )	0.0	19.96	33.63	20.42
Other rural development payments (EUR·ha <sup>-1</sup> )	3.25	1.01	1.76	0.38

During the years 2013-2015, the economic results of farms varied (tab.3). In the period of 2014-2015, the level of income from a farm decreased drastically in Estonia. Compared to 2013, it was 61% lower. There were changes in the level of income of a family-owned agricultural holding. Income per 1 ha of farmland decreased in Poland and Estonia but in Lithuania and Latvia increased by 23.49-36.68 EUR·ha<sup>-1</sup>. There are many reasons. On one hand, this is probably due to the changes in the area of agricultural holdings' farmland, and on the other, due to lower mean income in 2013-2015 caused by unfavorable market conditions, mainly lower prices of sold agricultural products. In the case of farms in Latvia and Lithuania, the results in 2014 were the least favourable. Meanwhile, net value added and agricultural income decreased systematically in Polish farms. This was the result of changing market conditions. The main cause was the Russian embargo on Polish agricultural products, particularly fruits and vegetables. Starting from August 2014, the border was closed to Polish products. The situation began to improve only in 2016, when export opportunities to other markets appeared. It should be noted that reaching this level of income was possible thanks to public subsidies. Family farm income in Estonian, Latvian and Lithuanian farms was positive only due to subsidies. Otherwise, income would have been negative. In Poland in 2013 and 2015 the family farm income corrected was positive, but at a very low level 549 and 238 EUR·FWU<sup>-1</sup> Such a level of income is unacceptable to life.

*Table 3: Economic results of farms benefiting from subsidies for sustainable production (own calculation based on FADN data)*

Specification	Estonia	Lithuania	Latvia	Poland
2013				
Net added value (EUR·AWU <sup>-1</sup> )	16 619	8 693	8 181	7 018
Family farm income (EUR·ha <sup>-1</sup> )	124.76	265.77	139.67	524.56
Family farm income (EUR·FWU <sup>-1</sup> )	13 676	8 772	6 375	6 511
Family farm income corrected (EUR·FWU <sup>-1</sup> )	-13 354	-689	-7 157	549
2014				
Net added value (EUR·AWU <sup>-1</sup> )	14 564	6 775	8 068	6 441
Family farm income (EUR·ha <sup>-1</sup> )	52.41	209.27	154.66	473.15
Family farm income (EUR·FWU <sup>-1</sup> )	8 074	6 613	6 668	5 805
Family farm income corrected (EUR·FWU <sup>-1</sup> )	-15 453	-2 581	-7 798	-12
2015				
Net added value (EUR·AWU <sup>-1</sup> )	14 903	8 897	10 201	6 045
Family farm income (EUR·ha <sup>-1</sup> )	52.35	270.36	209.19	422.97
Family farm income (EUR·FWU <sup>-1</sup> )	9 301	8 830	8 995	5 427
Family farm income corrected (EUR·FWU <sup>-1</sup> )	-14 618	-010	-5 932	238

#### 4. CONCLUSION

Agriculture in the Baltic states is very diverse in terms of farm sizes and relationships between production factors. Organic farms, which are considered to be the most favourable to the environment, also vary in surface area. However, limiting the scope to organic production would be an oversimplification. The analysis conducted indicates that the studied farms from Baltic States realize measures that protect the environment and thus contribute to implementation of the concept of sustainable agriculture. All farms benefiting from public subsidies must conduct production according to environmental requirements, regardless of their specialization. Commercial farms engaging in intensive production face particular challenges. The environmental hazards are the greatest in such farms. The results of the conducted analysis indicate that farmers are interested in production consistent with the requirements of sustainable development. Farmers benefit from various forms of financial support for farms. Environmental subsidies including organic production and subsidies for agriculture in less favoured areas (LFA) are the most significant. Subsidies for agricultural holdings contributed to improving their economic situation. During the years 2013-2015, family farm income per working person in the farmer's family increased by 15% in Lithuania and Latvia. In other countries (Estonia and Poland) the level of income decreased. It should be emphasized that this level of income was only possible thanks to subsidies. Financial support of farms with public funds has contributed to improving their economic situation. The share of subsidies in the income of a family-owned farm is particularly distinct. In many farms, income consisted solely of subsidies, and without them, the financial result would have been negative. A similar situation occurred in all studied Baltic states. Therefore, there is a low dependence between the income of a farm and labour efficiency.

**ACKNOWLEDGEMENT:** *The research was conducted within S/WZ/2/2015 project and financed from the Ministry of Science and Higher Education.*

**LITERATURE:**

1. Duer, I., Fotyma, M., Madej, A. (2002). Kodeks dobrej praktyki rolniczej, MRiRW-MŚ-FAPA, Warszawa.
2. European Commission Agricultural and Rural Development 2015. *FADN, Standard reports*, [http://ec.europa.eu/agriculture/rica/database/database\\_en.cfm](http://ec.europa.eu/agriculture/rica/database/database_en.cfm)
3. Gabrusewicz, W. (2007). Podstawy analizy finansowej. PWE, Warszawa.
4. Koloszko-Chomentowska Z. (2015). The economic consequences of supporting organic farms by public funds: case of Poland. *Technological and Economic Development of Economy*, Vol. 21(2), pp. 332-350. DOI: 10.3846/20294913.2014.944957
5. Lobley M., Butler A., Reed M. (2009). The contribution of organic farming to rural development: An exploration of the socio-economic linkages of organic and non-organic farms in England. *Land Use Policy*, Vol. 26(3), pp. 723-735. <https://doi.org/10.1016/j.landusepol.2008.09.007>
6. Mykhailovych Gazuda S. (2013). Regional prerequisites of rural development. *Economic and Management* No. 5 (4), p. 180-186.
7. O'Hara J.K., Parsons R.L. 2013. The economic value of organic dairy farms in Vermont and Minnesota. *Journal of Dairy Science*, 96(9), pp. 6117-6126. DOI: 10.3168/jds.2013-6662.
8. Raport o stanie rolnictwa ekologicznego w Polsce w latach 2015-2016. Inspekcja Jakości Handlowej Artykułów Rolno-Spożywczych, Warszawa 2017.
9. Zaleski J. (2015). Ocena wpływu Programu Rozwoju Obszarów Wiejskich 2007-2013 na gospodarkę Polski. Raport końcowy, Wrocławska Agencja Rozwoju Regionalnego, Wrocław.
10. Zimnoch K. (2018): Zasoby wewnętrzne w rozwoju lokalnym na przykładzie województwa podlaskiego. *Przedsiębiorczość i Zarządzanie* Vol. 6, No. 1(2018), p.42-51.

## PROFIT AND ITS CORRELATED RISK APPEARING WHILE INVESTING IN 2008-2018

**Rafal Parvi**

*WSB University in Wroclaw, Faculty of Economics in Opole  
Wroclaw, Poland  
rafalp4@o2.pl*

### **ABSTRACT**

*When discussing the issues of finances, it is particularly vital to concentrate on the efficiency of the market and refer it to an alternative risk for an income. The notion of an efficient market refers to the efficiency in terms of information, which means that prices must reflect all information. Thus, in order to be able to invest on the market, one should have information and knowledge allowing for correct investments with the lowest risk and the highest profit. It must be remembered that investing in financial instruments is connected with a possibility of both earning profits and suffering losses.*

**Keywords:** *finances, investing, financial instruments, profit, risk*

### **1. INTRODUCTION**

To invest effectively in financial instruments, it is important to get to know a financial market, analyze its functioning and the risk resulted from investing on it. At the same time, it is necessary to examine the rate of return on investment on a financial market and a profit that can be earned, or take into account a loss that will be incurred in a given period of time. Investing in financial instruments requires substantive and technical preparation and having current information used for predicting what may be expected in the time when we want to make investments. It is impossible to invest on a quick pick basis as it is not a game of chance. It is a specific financial instrument which has a corresponding rate of return in a given period. Therefore, one should get to know financial instruments which have an investment risk where we would not lose the capital; the risk of losing 50% (or even over 100%) of the capital [Parvi, 2016, pp. 53-64].

### **2. FINANCIAL MARKET**

The theory of finance consists in explaining how people and companies or partnerships behave on a market and which effects are derived from it. What matters in finances are not only financial assets, but also financial projects and investments. When discussing the matters related to finances, it is very important to concentrate on the efficiency of the market and refer it to an alternative risk for an income. The notion of an efficient market refers to the efficiency in the efficiency in terms of information, which means that prices must reflect all information. The example may be the value of a bond bought in Poland and the value of a bond bought in Greece. It is well-known that a country that is solvent and has a possibility to repay its debt holds bonds of such profitability which are cost-effective for investors. While the country which has less profitable bonds in its offer, due to its potential insolvency, will get the value that is considerably lower or zero. That is why information is so crucial; it must be included in the price of financial instruments [Brigham, Gapenski, 2000, pp. 161-162]. It may be observed there are three forms of the efficiency of a market: low, medium and high. If there is a low efficiency of the market, then it means that all information included in the future movements of the price values are reflected in the current market prices. In this situation it may be noted that it is of no importance what occurs today. It does not affect a today's or tomorrow's price in any way as the price values from the past affects the present entirely. It may be proved that a great amount of empirical evidence supports the form of low efficiency of a market.

In the case of a medium form of the efficiency of a market, it must be observed that it includes the form of low efficiency of a market, but it is based on the fact that current market prices reflect both future prices and all information that is publicly available. Therefore, it must be explained here that the future does not affect significantly the values as all previous prices are corrected with open-access information. This means that any information about the change of market prices in the presence of a medium efficiency are corrected with public information, e.g. the price of petrol will be corrected with the information that drilling platforms were closed in Libya due to riots incited in this country and the prices of petrol will increase that day since OPEC does not make any decision on the increase in the exploration of oil. Then, it is normal that prices of petroleum that were maintained throughout the year increase instantly from one day to the next. The high efficiency of a market indicates that current market prices reflect all information that is publicly and privately available. This means that a market may function correctly. This is the form of high efficiency. It is known that such a thesis would not be true at any time as there is always a company/corporation or a country which will have the information more quickly than the public opinion. However, in this form of efficiency each and every entity participating in a market could effectively manage its financial resources with no detriment to its property. Thus, the bankruptcy of a bank or the sale of securities of any entity would be known quicker. This would influence a whole market positively, but such a situation is unlikely to happen in the reality.

### **3. PROFITS AND LOSSES WHILE INVESTING IN FINANCIAL INSTRUMENTS**

While investing in financial instruments from the risk (zero, 50%, 100% and higher, they should be selected sensibly and observed on a market. Usually, it manifests itself in the way that the risk on a market is estimated and compared to an income. Taking this into account, the selection of any financial instruments, i.e. bonds, shares, investment funds or derivative instruments should be based on the comparison of the risk to the income. In this case, when the risk becomes higher, it should be limited by choosing a lower income and a lower risk. Moreover, this type of selection should be approached optimally since one's portfolio characterized by this level of risk should be diversified. Diversification means that the selection should concern these financial instruments which would reduce the risk to the minimum. Therefore, it is possible to purchase instruments of a high and low risk, which leads to their balancing, i.e. diversification of the portfolio of financial instruments. However, the strategy of purchasing and selling of financial instruments should be considered as this would minimize the transaction costs and the possibility of purchasing them. Practically, it means that it is necessary to purchase financial instruments in the way that the transaction costs do not exceed the threshold of the value with which we would need to wait a longer period of time for its return and the possibility of purchasing in different periods since the investment value on this day could have a greater buying power on the following day. Therefore, it is not recommended to make purchases on a given day for all cash. Purchasing may be distributed in time as it must be taken into consideration that there will be not only a return on investment, but also a decrease in the value of financial resources. Consequently, there would be also a decrease in the possibility of buying another financial resources at a lower price in order to balance their value in a held portfolio. After setting the time and value of investments, another issue to be considered and estimated is the risk. The risk has been defined as "a threat or danger, exposure to a loss or damage." Thus, it may be noted that the risk is accompanied by a threat of an unfavourable event. As per the whole set of investments, it is necessary to consider the risk in a special manner and have it in mind when selecting financial instruments. Presumably, selecting derivative instruments which are most likely subject to the risk as well as the State Treasury Bonds we will consider the risk in 50%. Term contracts constitute the risk in 100%, whereas the State Treasury Bonds constitute a zero risk. Therefore, planning the risk is extremely important.



On the market, there is an investment risk which may lead to a situation when the earned income is lower than the one we expected to achieve. The distribution of probability of the expected rate of yield should be also specified. This refers to the risk that may affect all participants in a market. It is connected with the probability of achieving a lower income than expected. The mentioned distribution of probability is the basis of a risk measurement. This may be illustrated by means of a purchase of bonds, shares and term contracts.

*Table 1: Rate of income obtained from selected financial instruments (Source: Own elaboration).*

<b>Economy / time</b>	<b>Presence of the occurred condition</b>	<b>Bonds and their income</b>	<b>Shares and their income</b>	<b>Term contracts and their income</b>
Slump	50%	4%	-30%	-100%
Stabilization	70%	3%	10%	40%
Boom	50%	3%	30%	110%
Summary	X	10.0%	10.0%	50%

The weighted mean of the probability results of the appearance of an expected value, i.e. a rate of yield for bonds.  $50\% \times 4\% + 70\% \times 3\% + 50\% \times 3\% = 0.02 + 0.021 + 0.015 = 0.056$  which is 5.6%.

The weighted mean of the probability results of the appearance of an expected value, i.e. a rate of yield for shares.  $50\% \times -30\% + 70\% \times 10\% + 50\% \times 30\% = -0.15 + 0.07 + 0.15 = 0.07$  which is 7%.

The weighted mean of the probability results of the appearance of an expected value, i.e. a rate of yield for term contracts.  $50\% \times -100\% + 70\% \times 40\% + 50\% \times 110\% = -0.5 + 0.28 + 0.55 = 0.33$  which is 33%.

It is clearly visible that while investing in financial instruments such as bonds - the rate of yield in different types of economy equals 5.6%; shares - the rate of yield in different types of economy equals 7%, and derivative instruments - the rate of yield in different types of economy equals 33%. Simultaneously, it must be stressed that bonds have a zero risk of losing the initial capital, whereas the purchase of shares has the risk up to 50% of losing the capital. In the case of derivative instruments, the risk of losing the capital is more than 100%. When calculating the rate of yield achieved from particular financial instruments, it is possible to calculate the expected rate of yield obtained from all held financial instruments and present it as a weighted mean.

$$(5.6\% + 7.0\% + 33.0\%) / 3 = 15.2\%.$$

As shown, the expected value of income achieved from a diversified portfolio of financial investments equals 15.2%.

#### **4. BASIC FINANCIAL INSTRUMENTS IN THE THREE GROUPS OF RISK**

Bonds, commonly known as securities of the lowest risk, are securities that produce a definite income to their holder. They constitute a proof of liability ascertaining the right of its holder to receive the reimbursement of a loan and a definite income in the form of interests in a determined term and mode from their drawer [Czekaj, 2008, pp. 27-29; Penc, 1997, pp. 11-14].

The price of a bond may be written in the following way[Jajuga, Jajuga, 2006, pp. 138-143]:

$$P_0 = \frac{O}{1+r} + \frac{O}{(1+r)^2} + \frac{O}{(1+r)^n} + \frac{W_n + O}{(1+r)^t}$$

whereas:

O – paid interests in the t period during the year,

W<sub>n</sub> – nominal value of the bonds,

n – lifetime of the bonds in years,

r – profitability till the time of redemption in years.

In the years 12.2008 – 11.2018, the interest rate of bonds oscillates from 2.00% up to 6.50%. Bonds may be bought in a bank or on a Stock Exchange. They may be 2-, 3-, 4- or 10-year bonds. They bring profits with an interest rate of 2.00% - 6.50% (in November it is 3.05%). As per above, it may be said that bonds are the safest investment of capital (Fig. 1). However, there are countries, e.g. Greece, which in the time of recession and financial crisis promise their investors an interest of bonds between 3.5% and 35% in the period 2011 – 2012, which is equivalent to financial absurdity as this country does not produce GDP or its GDP is nearly zero.



Figure 1: The interest of 10-year bonds in Poland in the years 2009r. - 30.11.2018. (Source: stooq.pl).

Shares, as securities confirming the participation of their holder in the capital of a joint-stock company, are a financial instrument of a lower risk and a higher rate of the expected income. Due to the way of transferring the title deed to property rights, shares must be divided into two categories: registered shares and bearer's shares. The valuation of shares is carried out by calculating the value of shares as a discounted value of dividends in the period of maintaining shares + a discounted value of a sale price.

The valuation of ordinary shares is connected with the acquisition of information regarding the value of dividends at the end of each year and the price that an investor expects to get from the sale of shares [Parvi, 2014, pp. 179-185; Parvi, 2016, pp. 53-64]:

$$P_0 = \frac{D_1}{(1+K_s)^1} + \frac{D_2}{(1+K_s)^2} + \frac{D_n}{(1+K_s)^n}$$

whereas:

D – dividend to be received by shareholders in a given year,

$P_0$  – current market price,

$K_s$  – demanded rate of yield from shares,

n – a period of a given year when the dividends are to be paid out.

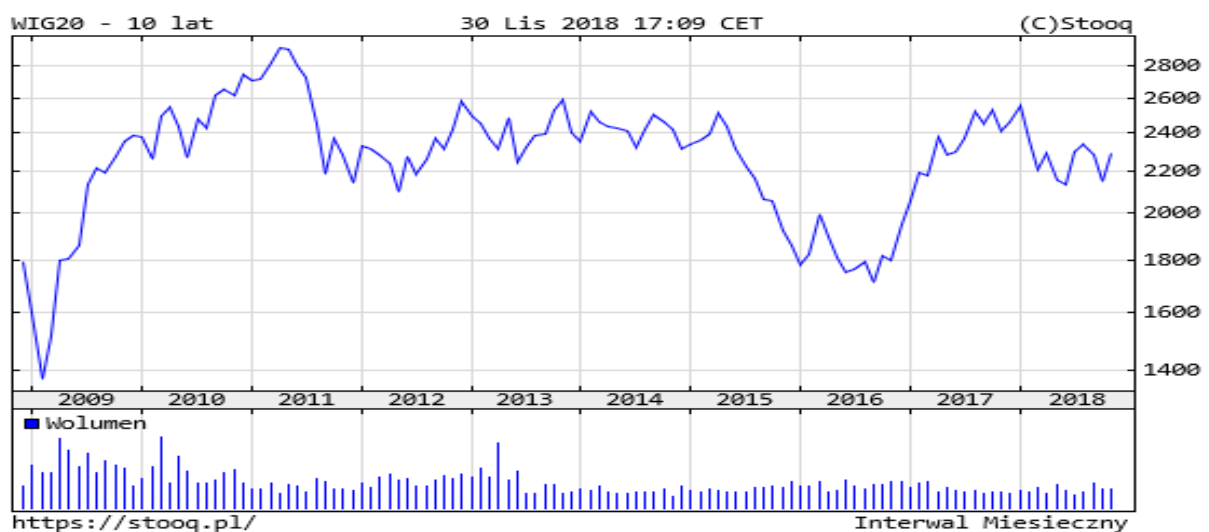

Figure 2: Shares – the WIG20 index in Poland in the years 12.2008 - 30.12.2018 (Source: *stooq.pl*).

Shares allow for investing with an increased risk, but they may bring a greater profit. However, it must be remembered that it is a financial instrument with a 50% risk of investing. The value of the WIG20 index oscillates between 1350 and 2850 points in the years 12.2008 – 11.2018. In the years 2008 - 2018, there was return of an upward tendency; there was solely a lateral movement (see Table 2). Derivative instruments, also known as derivatives, are a type of a financial instrument which depends on a basic (underlying) instrument. What characterizes them is the fact that they refer to the future, i.e. a future date and price, but they are entered into earlier. An underlying instrument may be: shares, bonds, value of rates, value of an interest rate, value of a stock exchange index and some extraordinary indicators such as a number of winter days, volume of heavy rainfall weather derivatives. Derivative instruments may be grouped in two categories: instruments of a symmetrical risk (term contracts of different types: forward, futures or swap) and instruments of a non-symmetrical risk (options, warranties, convertible bonds) [Sopoćko, 2010, pp. 58]. As already mentioned, derivative instruments constitute the most dangerous financial instrument in terms of a risk. Investing in these instruments may result in the loss of the whole initial capital and surcharge on an initial capital with an additional one to cover the suffered loss. It is held in this way that one invests in term contracts for a definite period of time and for specific purposes, i.e. purchasing or selling a contract at a determined price, expecting it will bring a definite income which is very high and simultaneously exceeds the income from shares several or more times.

However, it must be remembered that a risk and a direction (of purchase or sale) that are assessed incorrectly may lead to situation when the overall deposit one has for the security of a contract is not sufficient and there is a need to pay a surcharge on a deposit with a definite amount of money. Term contracts should be recommended to those who are acquainted with investing in derivative instruments, possess a specialist knowledge of markets of particular countries, Europe, Americas, Far East and constantly monitor the economic policy of their country, European Union and the world. Term contracts require primarily that a holder purchases or sells a term contract in the future at a definite price in a definite period. Term contracts may appear in the form of a contract for the WIG20 index, which is most popular, or for shares and other financial instruments. To calculate the value of a contract, it is necessary to refer to the value of a financial instrument for which the contract is bought or sold. Contracts for WIG20 must be defined in the following manner: The value of a contract refers to the value of WIG20, which means that if the value of WIG20 is equal to 2250 points, then the value of a contract should oscillate within the limits of 2250 points. Purchasing or selling a contract for WIG20, a purchaser counts for an increase or decline of WIG20 and at the same time for a profit earned by this contract. Profits may be very high, but also losses may exceed 100% of the invested capital (Fig. 3).

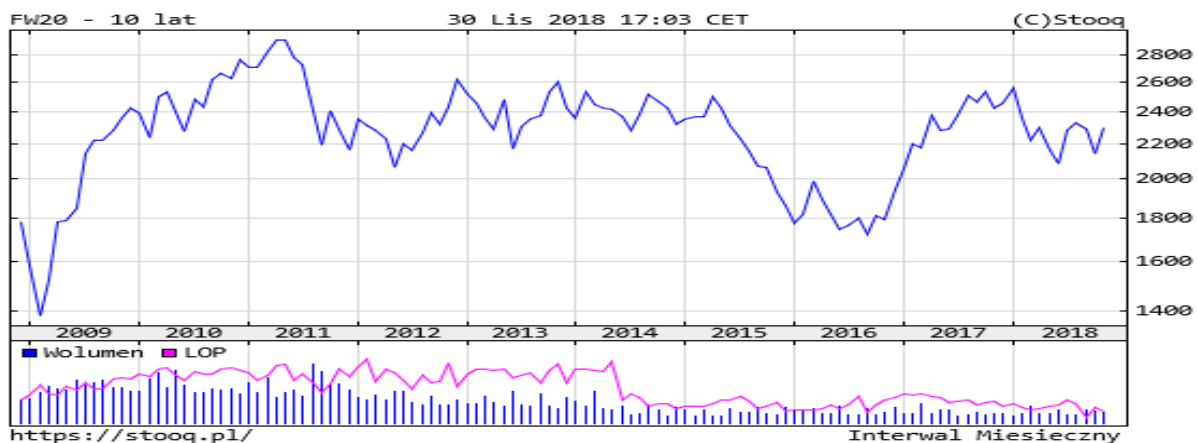

Figure 3: Term contracts in WIG20 in Poland in the years 12.2008 - 11.2018 (Source: [stooq.pl](https://stooq.pl/)).

In the years 2004 – 05.2014, the value of term contracts in WIG20 oscillated between 1350 and 3900 points. It is clear that the tendency is marked as downward, and currently as lateral. With adequate knowledge of investing, it is possible to earn a considerable profit. The ignorance of the market, however, may lead to a substantial loss.

## 5. CONCLUSIONS

It must be observed that investing in financial instruments is connected with expenditures made by an investor in a definite period of time in order to increase the owned property. Investments may be also divided into investments in a fixed capital, i.e. investments in immovables or immaterial and legal values. Long-term investments, as indicated by the name, should be executed in a long period of time, i.e. over one year. Thus, a specific income from an invested capital cannot be expected before the lapse of one year (and more). Long-term investments are connected with waiting for a definite income in particular years and may be also linked to the capitalization of interests. Therefore, the enumerated financial instruments may be grouped into: short-term and long-term instruments. Undoubtedly, short-term investments include yearly bonds, shares intended to be cashed in before the lapse of one year and term contracts.

However, when one expects a higher profit, it may be achieved by means of bonds invested for several years, shares that will be sold after the lapse of over a year and long-term deposits. Investing in financial instruments, one may assume the risk connected not solely with gaining any profit, but also the possibility of losing the capital. This is related to a change of economic conditions on the market and the inversion of upward or downward tendencies, i.e. a change of demand and supply of a given financial instrument.

#### **LITERATURE:**

1. Brigham E., Gapenski L. (2000). „*Zarządzanie finansami*”, PWE, Warszawa, 37 p., 161-162 p. ISBN 83-74265-09-6.
2. Czaekaj J., (2008). „*Rynki, instrumenty i instytucje finansowe*”, PWN, Warszawa, 2008. 27-29 p. ISBN 978-83-01-15297-0.
3. Jajuga K, Jajuga T., (2006). „*Inwestycje. Instrumenty finansowe, aktywa niefinansowe, ryzyko finansowe, inżyniera finansowa*”, PWN, Warszawa, 138-143 p. ISBN 978-01-14957-4
4. PARVI R., (2014). “*Share price of the companies listed on the WIG-UKRAINE and their fair value*”. Itall Ltd. 179-185 p. ISBN: 978-80-554-0865-1.
5. PARVI R., (2016). Fair value of the banking sector companies quoted on the Warsaw Stock Exchange in Poland within 2007-2016 and their financial analysis. Publisher Varazdin Croatia, Faculty of Management University of Warsaw, ISSN 1849—7535, pp 53-64.
6. PENC J. (1997). “*Leksykon Biznesu*”. Placet. Warszawa. 11-14 p. ISBN 83-85428-20-8.
7. SOBCZYK M., (1997). „*Matematyka finansowa*”, Placet, Warszawa, 263 p. ISBN 83-85428-13-5.
8. SOPOĆKO A., (2010). „*Rynkowe instrumenty finansowe*”, PWN, Warszawa, 58 p. ISBN 978-01-16480-5.

# POTENTIAL CONSEQUENCES OF WORKING AND STUDYING TOURISM AND HOSPITALITY: THE CASE OF STUDENTS' BURNOUT

**Aleksandra Grobelna**

*Gdynia Maritime University, Poland  
Faculty of Entrepreneurship and Quality Science  
a.grobelna@wpit.umg.edu.pl*

**Anna Tokarz-Kocik**

*University of Szczecin, Poland  
Faculty of Management and Economics of Services  
anna.tokarz@wzieu.pl*

## **ABSTRACT**

*Nowadays an increasing number of tourism and hospitality students (T&H) decide to work during their study time. It results from many reasons, such as a necessity to possess and develop practical skills and abilities, to gain job experience, to earn money and support themselves financially, etc. Working in the T&H industry is characterized by long, irregular and unsocial hours, night and weekend schedules, or having to deal with heavy workload and stress. All these demands of working in T&H may interfere with students' academic life and can be reflected in their fatigue, tiredness and strain when studying or attending classes. This study develops and tests a research model that investigates the relationships between time workload experienced by working students and their exhaustion from their studies. Additionally, an attempt was made to answer the question whether the reasons why young people decide to work while studying may have any consequences for their feeling of study exhaustion, as one of the dimensions of students' burnout. This study was conducted among tourism and hospitality (T&H) students who, at the time of the research, were both studying and working in T&H. It means that only students with current working experience took part in this study. A questionnaire survey was conducted to elicit responses concerning students' work, their attitudes toward the undertaken studies and their socio-demographic characteristics. 121 questionnaires were analyzed in this study. The findings revealed that there are positive and significant relationships between time workload experienced by working students, reflected in a number of days per week at work and a number of hours per day at work, and the students' exhaustion. The results show that only earning money to cover the living expenses positively and significantly relates to students' exhaustion. Noteworthy, in the case of these respondents, having some kind of pressure to work (to cover the living expenses) may put a particular strain on their successful management of their work and student roles. Implications of the results are discussed, and a suggestion for future research is provided.*

**Keywords:** *tourism and hospitality, students, employees, burnout, time workload*

## **1. INTRODUCTION**

Activities in the tourism and hospitality sector are characterized by high labour intensity. The provision of services and effective competition with other entities requires not only ensuring an adequate number of employees but, above all, employees with appropriate professional competences. If entrepreneurs want to make human capital a source of permanent competitive advantage, they should undertake activities conducive to acquiring qualified human resources, i.e. graduates or students of higher education institutions of tourism and hospitality (T & H). Nowadays, an increasing number of tourism and hospitality students (T&H) decide to work during their study time.

It results from many reasons such as necessity to possess and develop important skills and abilities, to gain job experience, to earn money and support themselves financially, particularly to cover the tuition and other fees, etc. Among other advantages of students' work experience, the literature underlines broadening their knowledge about various tourism sectors, increasing awareness of the industry diversity or an opportunity to view the organization in more objective way, etc. (Leslie and Richardson, 2000). Among the people who are currently studying and working at the same time are mainly the representatives of the Y generation, i.e. people born in 1980-1998 (Kizielewicz, 2018). They are individuals with a strong sense of their own worth, characterized by creativity, and strongly oriented towards personal development (Wojtaszczyk, 2012; Skrzyszewska and Milić Beran, 2016). Representatives of this generation are interested in an individualized approach to their own development. They expect that the organization will provide them with access to coaches and mentors caring for their career path. The main motivators that stimulate the activity of employees from this generation are the opportunity to develop at work, and the maintenance of a work-life balance. The fact that only a small group of the young generation (9%) is willing to work permanently in the tourism industry is a disadvantage for employers in this industry (Ranking<sup>1</sup> 2017). This is mainly due to negative ideas about work in tourism, which is confirmed by research conducted in Poland (Kachniewska and Para, 2014; Bednarska and Olszewski 2011; Grobelna and Marciszewska, 2016; Tokarz-Kocik, 2017a) and abroad (Jiang and Tribe, 2009; Kusluvan, and Kusluvan, 2000; Richardson and Thomas, 2012; Teng, 2008; Weaver, 2009). The most emphasised are unfavourable working conditions, such as seasonality of employment, partial employment, irregular working hours, work during the night hours and during weekends, numerical dominance of jobs requiring low qualifications and hence low wages. Moreover, limited expenditure on employee training, especially for employees at lower positions is observed (Dolot, 2017). Employment of people from generation Y is associated with a high risk of staff turnover (Brown et al., 2015). According to research, 75% -90% of young people cannot imagine their becoming affiliated with one employer for more than 3 years (Massalski, 2012). The lack of loyalty results from the desire to develop, taking on new challenges, looking for diversity, and great mobility. Generation Y representatives do not get attached to the workplace. They leave if the company does not meet their expectations. Therefore, employers in the tourism sector should especially support their young employees who improve their qualifications at a university. All the more that people studying and working at the same time can be particularly overloaded. In addition, this situation is escalated by the high requirements of the educational process implemented in the T & H area as well as the high requirements of the work process in the tourism sector (T & H industry). It is not surprising then that working students, devoting their individual and limited resources (such as time and energy) to demanding work in the tourism industry, may experience their lack in the other area of their life, which are studies, resulting in fatigue and exhaustion of learning and the realised studies. In other words, overlapping of the requirements of the work process and studies may lead to many negative consequences in young people, including students' burnout from their studies. Based on the above, this study develops and tests a research model (Fig. 1) that investigates the relationships between time workload experienced by working students and their exhaustion (as one of the burnout dimensions) connected with their studies. Additionally, it is examined whether the reasons why young people decide to work while studying may have any consequences for their feeling of study exhaustion.

---

<sup>1</sup> The ranking of the 100 most-desired Employers 2017 was developed on the basis of surveys, which covered 27.6 thousand students (from 64 Polish universities, studying 97 subjects). Only 9% of the respondents expressed their willingness to work in tourism. Banks (42% of indications), accounting and auditing companies (23%) and media (21%) enjoyed greater popularity.

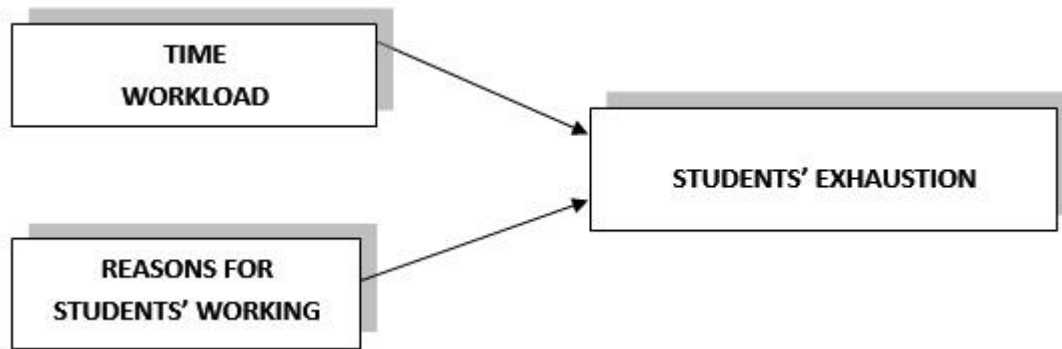

*Figure 1: Research model*

The Conservation of Resources (COR) theory may provide a theoretical framework for the relationships proposed in this model. In line with the COR theory, people seek to acquire, retain and protect certain resources which are defined as “those objects, personal characteristics, conditions, or energies that are valued in their own right, or that are valued because they act as conduits to the achievement or protection of valued resource” (Hobfoll, 2001, p. 339). Perceived and actual loss of resources or lack of gain may be sufficient to produce stress (Hobfoll, 1989). In the light of the premises of this theory, it is proposed that working students are likely to lose their resources (time and energy) while juggling they work and student roles, which may induce stress and finally lead to their exhaustion. The research value of this study may results from the fact that to the best of the Authors’ knowledge, studies on T&H students’ burnout are still limited (see Uludağ and Yaratan, 2010), particularly in Poland. Furthermore, this study focuses on burnout (exhaustion) among students, viewed as non-occupational individuals. This broadens the original theory of burnout, which focuses mainly on persons who have occupations (Uludağ and Yaratan, 2010).

## **2. THE ESSENCE OF THE BURNOUT SYNDROME: THE CONTEXT OF STUDENTS**

The appearance of the concept of burnout in the psychological literature is attributed to the psychotherapist Herbert Freudenberger. In 1974, in an article entitled Staff Burn-out, he defined burnout as a "state of tiredness or frustration resulting from devoting himself to a matter, a way of life, or relationship, which did not bring the expected reward" (Freudenberger 1974, p.159). In addition to the feeling of exhaustion, the author mentioned other symptoms accompanying burnout. Burnt-out employees complained of somatic symptoms (e.g. frequent headaches, disturbances of perception, insomnia) and they had a tendency to react with anger (Chirkowska-Smolak 2009). The most frequently quoted theory of burnout is the concept of Christina Maslach, and her co-worker Susan Jackson. Occupational burnout is defined by them as a "psychological syndrome of emotional exhaustion, depersonalization and a reduced sense of personal achievement that occurs in people who work with people in a certain way" (Maslach and Jackson, 1981, p. 99). Occupational burnout is considered to be a "prolonged response to chronic job stressors" (Maslach et al., 2001, p. 405). Burnout syndrome develops in three dimensions (Maslach, 2011):

1. emotional exhaustion,
2. depersonalization,
3. a reduced sense of personal achievement.

Emotional exhaustion can be defined as a person's sense of being overly exploited emotionally, with his/her emotional resources having been significantly depleted. Characteristic of exhaustion is also the sense of excessive overload, discouragement to work and reduced activity. In order for the exhaustion to appear, the state of high arousal or work overload must



first occur. Exhaustion is accompanied by loss of energy and enthusiasm for action, lack of joy of life, increased impulsiveness and irritability. Free time and sleep do not bring the desired regeneration of strength. It is necessary to make more effort than before to perform at work at the right level. At the same time, emotionally exhausted people feel that they are not able to continue to work effectively. In social relations with others, emotional bonds are loosened, which results in the break-up of friendships and distances them from possible sources of support. Depersonalization, also referred to as cynicism, consists in the increasing of psychological distance towards people who are recipients of a given service. You can observe negative attitudes toward others, coldness, indifference and the so-called thick skin, as well as distancing themselves from colleagues - tendencies to isolate themselves from them. Depersonalization is the result of excessive exhaustion as well as the loss of emotional and physical resources. It is also one of the forms of how to deal with the conflict between the value system and the lack of confirmation in the form of successes, justifying the reasonableness of the actions taken. Thus, it involves the loss of idealism. Although this attitude and the creation of a buffer that is supposed to protect against contacts with others is intended to protect oneself, it nevertheless means a negative, soulless or indifferent reaction to other people and their problems. As a result, relationships with others become impersonal. There is a danger that such an indifferent attitude will be perpetuated and will lead to dehumanization. A reduced sense of personal accomplishment is characterized by a reduced sense of own competence and successes achieved at work, a sense of inefficiency and loss of faith in one's own abilities. Lack of satisfaction related to professional work or other activity (e.g. studies) is accompanied by depressive moods, self-criticism, conviction about own uselessness and worthlessness. The sense of inadequacy is increasing and as a result, there may appear a sense of nonsense of work, resignation and willingness to withdraw from the profession. In the literature factors leading to employee demotivation which may result in job burnout are discussed (Dolot, 2015). Burnout may also be defined in the context of students. Burnout among students may refer to their feelings of being exhausted because of study demands, having a cynical and detached attitude toward the undertaken study, and feeling incompetence as students (Schaufeli et al., 2002). The consequences of student burnout are felt not only by working students themselves, but also by universities and the enterprises that employ students, and therefore all parties should be interested in changing this state of affairs. The literature on the subject lists a number of consequences of burnout and the impact of stress on the human component, such as increased tension and uncertainty, interpersonal difficulties, emotional disorders and less involvement in learning. For example, in a study by Uludağ and Yaratana (2010) among undergraduate hospitality and tourism students from Northern Cyprus, it was proved that students' emotional exhaustion, cynicism, and reduced professional efficacy were negatively associated with their vigor, dedication, and absorption. Burnout is essential for the functioning of the entire organization; it negatively affects the sense of satisfaction, leads to withdrawal, numerous absences, often having its finale in deciding to leave the organization (Yang, 2010). Stress also leads to a decline in efficiency and creativity (Çekmecelioğlu and Günsel, 2011, Grobelna, 2013). The main symptoms and warning signals indicating the phenomenon of burnout can be very diverse, and include, among others, perceived lack of willingness to work or study, overstrain, reluctance to go to work and university, lack of patience, touchiness and irritation, etc.

### **3. POTENTIAL ANTECEDENS OF STUDENTS' BURNOUT**

Potential causes of T & H students' burnout can be divided into two groups:

- overloading with duties at the university,
- work overload.

Most of hospitality programs require the completion of classroom work with practical training (e.g. internships, cooperative education placements, practices, etc.) as the obligatory part of degree requirements creating potentially more stress than traditional programs and making them different from many other disciplines (see Jogaratnam and Buchanan, 2004). Consequently, students of the hospitality and tourism field need to perform simultaneously both theoretically and practically during their educational process. Unsurprisingly, such confrontation with heavy study loads and intensive practical exposure may create a stressful study environment for these students. Under such conditions, they may experience the burnout syndrome, leading to academic erosion more frequently than is the case among students of other disciplines (see Uludağ and Yaratana, 2010). The specificity and nature of work in tourism also create numerous conditions conducive to the experience of stress. This is, among others, due to the following aspects (Grobelna et al., 2015; Rapacz, 2007; Tokarz-Kocik, 2017c):

- tourist and hospitality services are characterized by high labour intensity, and the possibilities of their automation are limited,
- services of high contact and relational character cause that during the service process there are numerous, mutual and intense impacts of the client and employee,
- service for guests with different personalities, temperaments and characters (often confrontational, problem clients) may provoke the occurrence of many difficult situations during service,
- diverse and high consumer expectations, that are especially stress-inducing when guests shape their requirements in an optimal way for them, without knowing any realities or difficulties in providing them.

In addition, as shown by the analysis of the literature of the subject (Karatepe and Aleshinloye, 2009; Yang, 2010), T & H employees are badly rewarded, burdened with many hours of work, they experience the necessity of meeting numerous demanding tasks, and often receive inappropriate training, and the work environment lacks friendly programs and social benefits. As a consequence, they become more susceptible to experiencing stress. To sum up, students working in the T&H industry may often experience high demands from both the industry and the university. On the one hand, they have to face typical industry characteristics while working, particularly long, irregular and unsocial hours, night and weekend schedules and heavy workloads (Karatepe and Kilic, 2007; Kuslivan, 2003; Kuslivan et al., 2010). On the other hand, they have to deal with high requirements of their studies. Juggling these competing demands may be particularly difficult and stressful for students, as working in such a demanding environment as T&H involves much of students' energy and time, leaving less of these limited resources for their studying. Thus, unsurprisingly, students working in this industry may be more tired, used up or emotionally drained while studying and attending classes. This can be exacerbated by the fact that T&H's unfavorable work schedules may be connected with many negative outcomes, including decreased quality of their sleep, anxiety, symptoms of depression or social problems (Brand et al., 2008), which, if experienced by working students, may contribute to their tiredness and exhaustion.

#### **4. MATERIAL AND METHODS**

This study was conducted among tourism and hospitality (T&H) students (employees) who, at the time of the research, were both studying and working in tourism and hospitality. It means that only students with current working experience took part in this study. Respondents came from higher educational institution (HEI) located in the Pomeranian Voivodeship, where tourism is perceived as an important regional economic sector that contributes to creating new workplaces (Marciszewska et al., 2017). Specifically, three HEI from Tricity (a tourist destination of the Pomerania Province) were selected on the basis of convenience and access to

students enrolled in tourism and hospitality courses. A questionnaire survey was conducted to elicit responses concerning students' work, their attitudes toward the undertaken studies and their socio-demographic characteristics. The questionnaires were administered at each institution and distributed to a captive audience, namely, students in a classroom during formal class time agreed with the lecturers of the participating HEI. A detailed explanation of the study purpose was provided to the students, who were also informed about their voluntary participation and assured about confidentiality of their answers. All questionnaires were anonymous. All respondents were bachelor students. Such controlled environment may contribute to achieving the maximum response. This technique may also have many other advantages: apart from low costs, it includes no strain of giving immediate answers, less possibility to feel embarrassed while answering sensitive questions, feeling rather comfortable while expressing true reactions to sensitive issues (see Gray et al., 2007). In this study, students' exhaustion (S\_EXH) was measured via five items from the Maslach Burnout Inventory–Student Survey (MBI-SS; Schaufeli et al., 2002). Sample items include: "I feel used up at the end of a day at university" or "I feel tired when I get up in the morning and I have to face another day at university". To ensure translation quality and adequate meaning of the applied items, they were originally prepared in English and then translated into Polish via the back-translation method. Responses to the scale items were elicited on a five-point scale, ranging from (1) strongly disagree to (5) strongly agree. Higher scores display a higher level of students' exhaustion from their study. Cronbach's alpha for the measure was .84, confirming internal consistency of the scale and its reliability. Descriptive statistics and correlation analysis were used to analyze the data. The collected data were analyzed using Statistical Package for Social Sciences (SPSS), version 25.

## 5. RESULTS

121 questionnaires were analyzed in this study. They were mostly filled in by females (77.7%) and students within the age range of 22–25 years (46.3%). Students pointed to a variety of T&H's branches within which they were working, such as hospitality services (43.8%), food & beverage (41.3%), travel agencies/tour operators (9.9%), tour guiding (3.3%), or transport services (1.7%). 41.3% of the students declared working in their T&H jobs less than 1 year; 30.6% of the study participants were working between 1 and 2 years; 12.3 % were working from 2 to 3 years; the remaining ones (15.8%) declared working over 3 years in the T&H industry. The respondents of this study were working 4.4 days a week on average. Most of the respondents (35.5%) stated that were working 5 days a week. Quite similar groups of students were working 4 (19.8%) and 3 (19%) days a week. Little less (12.4%) pointed to 6 days' work in a week. 5% of the respondents pointed to the longest working week – 7 days. The smallest group of students indicated working 2 or 1 day in a week –4.1% respondents in each of the groups, respectively. Analyzing hourly work schedule, the students were working 8.5 hours per day on average. The biggest group of participants (37.2%) indicated an 8-hour workday; 23.9% of the students pointed to longer work (9 or 10 hours per day), whereas 15.7% of this study respondents declared working even 11 or 12 hours per day. The remaining ones were working 6 or 7 hours per day (14.9%) and 5 or fewer hours (8.3%). The above data show that most students of the investigated group seem to experience typical characteristics of tourism and hospitality jobs, such as long work hours. Some of the students may also experience limited time off due to working many days per week. Investigating students' reasons for undertaking work in T&H while studying, they indicated a variety of their choices. 65.3% of answers were connected with a necessity to work to earn money in order to cover living expenses during the study time; 46.3% were related to getting practical experience; 44.6% of the students' answers referred to a necessity to broaden knowledge and increase practical skills, whereas 43.8% related to earning money to have a social and cultural life).

Some answers (38.8%) pointed to enhancing the general attractiveness on the labor market thanks to working. To verify the relationships between the study variables, Pearson's correlation was applied. The results of this study (Fig. 2) show that there is a relationship between time workload and students' exhaustion.

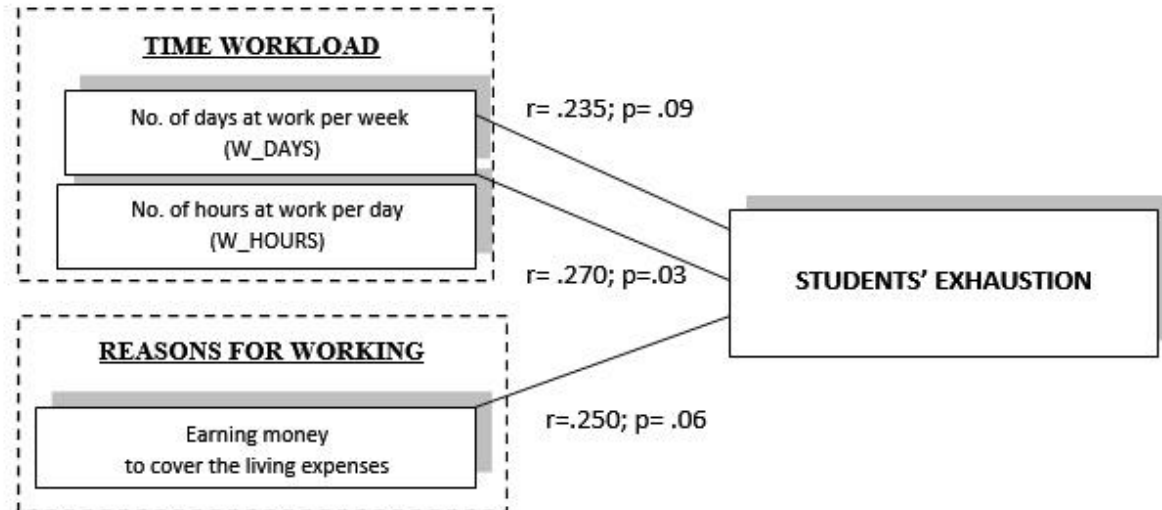

Figure 2: Verified model  
source: own research

More specifically, the findings revealed that there are positive and significant correlations between the number of days at work per week and the number of hours at work per day and the students' exhaustion. In other words, the more often students work during a week or the longer they work during the day, the more exhausted they may feel while studying, including tiredness when getting up in the morning and having to face another day at university, feeling used up at the end of their study day or feeling a strain while studying or attending classed, etc. This is no surprise, given the fact that the time and energy involved in working limits the time and energy available for studying. Among a variety of students' reasons for working, only earning money to cover the living expenses positively and significantly relates to students' exhaustion. It can be noticed that, in the case of the respondents of this study, having some kind of pressure to work (to cover the living expenses) puts a particular strain on their successful management of their work and student roles. Probably, in such a situation, work is gaining a kind of priority referring to the basic needs of working students, thus many of their resources can be devoted to work, leaving less of them (energy and time) to spend on studying, which can make students particularly prone to exhaustion and elevate levels of their tiredness, fatigue and strain, etc.

## 6. IMPLICATIONS AND CONCLUSIONS

This study aimed to examine a relationship between students' time workload and their exhaustion. Additionally, this study attempted to find any relationships between different reasons for students' working and their exhaustion from their studies. The results showed that in the case of the respondents of this study (employees-students) working in T&H may interfere with studying T&H, thus leading to serious consequences for the latter domain of students' life. An increase in both the number of working days per week and in the number of working hours per day may intensify the experience of time workload, reducing students' energy and time that should be devoted to their studies. Interestingly, among many reasons for working indicated by students in this study, only earning money to cover living expenses contributed to their exhaustion.

The potential explanation for that relationship may result from the fact that working to cover the living costs refers to fulfilling the students' basic needs. Thus feeling a strong obligation to work, they may be more likely to accept the hard conditions of work typical of T&H. As underlined by Jogaratnam and Buchanan (2004) "the need to support oneself financially and complete program requirements can become a significant source of stress" (p. 239). As a result, such students may experience an elevated level of exhaustion. Other reasons for working indicated in this study do not seem as obligatory as covering the living expenses and refer to fulfilling rather higher needs of young people (e.g. earning to have social/cultural life), so in these cases students may feel much more freedom whether to work or not, and decide to leave if only demands of their work are not no longer acceptable. A possibility to simultaneously work and study requires providing support for students both from educators who educate young people as future employees and transfer knowledge to business practice (Spodarczyk and Szelałowska – Rudzka, 2015) and the T&H industry that is particularly responsible for the quality of the youth's working experience. An example of a pro-student attitude of a university could be (Cybal-Michalska, 2013; Richardson and Butler, 2012; Richardson and Thomas, 2012; Schlager et al., 2011):

- including the student's professional work into the student's internship, which students are required to complete as part of the study program,
- inviting the student to share his experiences with the group (presentation of a chosen problem, which is part of the subject) - giving him additional points for willingness and undertaking such activity,
- supporting student when writing a diploma thesis, in which he could use his own observations and experiences, and try to solve the real problem which the company where he works is faced,
- the flexibility of lecturers regarding contact with a student-employee (e.g. flexible hours of consultation, remote contact - e-mail, etc.), and in justified cases, flexibility regarding the terms/dates of credits,
- due to the fact that only the compulsion to work for economic reasons (to stay in college) increased the exhaustion with studies, a greater recognition and sensitivity of the university regarding the social situation of students is needed - greater access to social scholarships and creating an atmosphere of mutual trust so that students can boldly and confidently ask for such support.

If tourism enterprises want to make human capital a source of sustainable competitive advantage, they should undertake activities that foster the acquisition of competent and committed employees who are able to actively participate in the implementation of the company's strategic goals. Cooperation with the education system in the field of education (cooperative education) is part of the catalogue of such activities (Chuang and Dellmann-Jenkins, 2010). Therefore, employers in the tourist industry should support working students through activities such as flexible duty roster or adjusting the number of duties to the study schedule. Employers must remember that their student-employee is a future specialist in a given field, which in the future may be a valuable work resource in an enterprise. Therefore, everything should be done to make it easier for him to complete his studies, to treat it as an investment in an employee, who will later repay it with his loyalty and commitment to work (Lipka, 2010; Tokarz-Kocik, 2017b). In summary, the lack of support for students-employees on the part of universities and employers may cause students to become exhausted and discourage them from further learning and working in the tourism industry. What is important is a partnership and active cooperation between universities, employers in the tourism industry and students. Thanks to it, all groups of stakeholders will benefit. For the academic youth, the most important effects of the analyzed cooperation will be the opportunity to develop practical

skills necessary to efficiently solve professional problems, which will increase their employability, verify the knowledge gained during didactic activities in practice and the opportunity to assess the attractiveness of a career path in a given industry (Bednarska, 2014). Higher education institutions can enrich the offered program content with aspects that favour the development of practical skills and social competencies desired by employers, and, as a consequence, strengthen their competitive position on the education market. Tourism enterprises - entering into the education process - will gain access to potential employees, will be able to verify the qualifications of students and their usefulness as members of the organization, and in the future will limit the costs of recruitment and adaptation and the negative consequences of excessive staff turnover. In addition, students can realistically support the company in its day-to-day operations by performing the tasks entrusted to them and, thanks to an innovative approach, provide creative solutions to the problems of its operation (Collins, 2002; Zopiatis and Constanti 2012; Yiu and Law 2012). This research was conducted only among students of three HEI from Tricity; therefore, a possibility to generalize its results is strongly limited. Future research should investigate the proposed relationships with both a larger sample of T&H students, including other HEI enrolling for T&H courses located in different geographical regions. However, despite that limitation, this study may provide a basis for discussion and future studies on relationships between working and studying T&H. Specifically, because in this study work interference with study was examined, it could also be interesting to explore whether and how studying T&H may potentially interfere with students' work.

#### LITERATURE:

1. Bednarska M., Olszewski M. (2011). Atrakcyjność pracy w turystyce jako determinanta potencjału konkurencyjnego przedsiębiorstw turystycznych, in A. Rapacz (ed.) *Gospodarka turystyczna w regionie: przedsiębiorstwo, samorząd, współpraca*, Prace Naukowe Uniwersytetu Ekonomicznego we Wrocławiu (157), Wrocław, 4-39.
2. Bednarska, M. (2014). Kariera zawodowa w hotelarstwie w opinii studentów-implikacje dla współpracy praktyki gospodarczej z systemem edukacji, *Journal Studia Oeconomica Posnaniensia* 2 (1), (262), 152-167.
3. Benckendorff, P., Moscardo, G., Pendergast, D. (eds.) (2010). *Tourism and Generation Y*. Wallingford: CABI.
4. Brand, S., Hermann, B., Muheim, F., Beck, J. Holsboer-Trachsler, E. (2008), Sleep Patterns, Work, and Strain among Young Students in Hospitality and Tourism, *Industrial Health* (46), 199–209.
5. Brown, E. A., Thomas, N. J., Bosselman, R. H. (2015). Are they leaving or staying: A qualitative analysis of turnover issues for Generation Y hospitality employees with a hospitality education, *International Journal of Hospitality Management* 46, 130-137.
6. Cekmecelioğlu, H.G., Günsel, A. (2011). Promoting creativity among employees of mature industries: the effects of autonomy and role stress on creative behaviors and job performance, *Procedia – Social and Behavioral Sciences* (24), 889–895.
7. Chirkowska-Smolak, T. (2009). Organizacyjne czynniki wypalenia zawodowego, *Ruch Prawniczy, Ekonomiczny i Socjologiczny* (4), 257-272.
8. Chuang, N.-K., Dellmann-Jenkins, M. (2010). Career Decision Making and Intention: A Study of Hospitality Undergraduate Students, *Journal of Hospitality & Tourism Research* 34 (4), 512–530.
9. Collins, A.B., (2002). Gateway to the Real World, Industrial Training: Dilemmas and Problems, *Tourism Management* 23 (1), 93–96.
10. Cybal-Michalska, A. (2013). *Młodzież akademicka a kariera zawodowa*, .Kraków: Oficyna Wydawnicza Impuls.

11. Dolot, A. (2017). Coaching Process and Its Influence on Employees' Competencies in the Hospitality Sector- Case Study, *International Journal of Contemporary Management*, 16(2), 75-98.
12. Dolot, A. (2015). Źródła demotywacji pracowników w świetle badań empirycznych, in: W. Rudny (ed.) *Studia Ekonomiczne, Zeszyty Naukowe Uniwersytetu Ekonomicznego w Katowicach* 229, Katowice, 21-34.
13. Freudenberg H. (1974) *Staff burn-out*, *Journal of Social Issues*, 1974, 30, 159-165.
14. Gray, P.S., Williamson, J.B., Karp, D.A. Dalphin, J.R. (2007). *The Research Imagination. An introduction to qualitative and quantitative methods*. Cambridge: University Press.
15. Grobelna A. (2013), Wybrane osobowościowe i organizacyjne uwarunkowania wypalenia zawodowego wśród pracowników branży hotelarskiej, *Folia Turistica* 28, 185-204.
16. Grobelna, A., Marciszewska, B. (2016). Undergraduate Students Attitudes towards Their Future Jobs in the Tourism Sector: Challenges Facing Educators and Business, in D. Vasilenko, N. Khazieva, (eds.), *Proceedings of the 4th International Conference on Management, Leadership and Governance ICMLG*, Saint-Petersburg State University of Economics, St. Petersburg, 138-145.
17. Grobelna, A., Sidorkiewicz, M, Tokarz-Kocik, A. (2015). Wybrane determinanty satysfakcji z pracy i efektywności pracowników w branży hotelarskiej, *Folia Turistica* 35, 25-45.
18. Grobelna, A., Tokarz-Kocik, A. (2016). Work–life balance and its importance for the work process in hospitality industry. A perspective of generation Y employees, in Z. Primorac, C. Bussoli. and N. Recker (eds.) *Economic and Social Development (Book of Proceedings)*, 16th International Scientific Conference on Economic and Social Development – “The Legal Challenges of Modern World” , Varazdin Development and Entrepreneurship Agency in cooperation with Faculty of Law, University of Split and University North Split., 489-497.
19. Hobfoll, S. E. (1989). Conservation of Resources: A New Attempt a Conceptualizing Stress. *American Psychologist*, 44(3), 513-524.
20. Hobfoll, S. E. (2001). The Influence of Culture, Community, and the Nested-self in the Stress Process: Advancing Conservation of Resources Theory. *Applied Psychology: An International Review*, 50(3), 337-421.
21. Jiang, B., Tribe, J. (2009). Tourism jobs – short-lived professions': Student attitudes towards tourism careers in China, *Journal of Hospitality, Leisure, Sport and Tourism Education* 8 (1), 4–19.
22. Jogaratnam, G., Buchanan, P. (2004). Balancing the demands of school and work: Stress and employed hospitality students. *International Journal of Contemporary Hospitality Management*, 16(4): 237-245.
23. Kachniewska, M., Para, A. (2014). Pokolenie y na turystycznym rynku pracy: fakty, mity i wyzwania, *Rozprawy Naukowe Akademii Wychowania Fizycznego we Wrocławiu* (45), Wrocław, 161-163.
24. Karatepe, O. M., Kilic, H. (2007). Relationships of supervisor support and conflicts in the work-family interface with the selected job outcomes of frontline employees. *Tourism Management*, 28 (1), 238–252.
25. Kizielewicz J. (2018). The impact of demographic variables on cruise travellers' behaviour in coastal tourist destinations, *Book of Proceedings of the 1st International Conference on Tourism Research – ICTR 2018* (ICTR), Academic Conferences and Publishing International Limited, Jyväskylä, 85 – 93.
26. Kusluvan, S. (2003), Characteristics of employment and human resource management in the tourism and hospitality industry, in Kusluvan S., *Managing employee attitudes and behaviors in the tourism and hospitality industry*, Nova Publishers, New York, 3-22.

27. Kusluvan, S., Kusluvan, Z. (2000). Perceptions and attitudes of undergraduate tourism students towards working in the tourism industry in Turkey. *Tourism Management*, 21 (3), 251–269.
28. Kusluvan, S., Kusluvan, Z., Ilhan, I., and Buyruk, L. (2010), The Human Dimension: A Review of Human Resources Management Issues in the Tourism and Hospitality Industry, *Cornell Hospitality Quarterly* 51 (2),. 171-214.
29. Leslie D., Richardson A. (2000). Tourism and cooperative education in UK undergraduate courses: are the benefits being realised?, *Tourism Management* 21, 489-498.
30. Lipka, A., (2010). *Inwestycje w kapitał ludzki organizacji w okresie koniunktury i dekonunktury*, Warszawa: Oficyna Wolters Kluwer Business
31. Marciszewska, B., Studzieniecki, T., Wanagos, M. (2017). Tourist arrivals in Poland and regional development-a case study of the Pomerania Province, in Potocan V., Kalinic, P., Vuletic, A. (eds), *Economic and Social Development (Book of Proceedings)*, 26 th International Scientific Conference on Economic and Social Development - "Building Resilient Society", Varazdin Development and Entrepreneurship Agency, Varazdin, Croatia Faculty of Management University of Warsaw, Warsaw, Poland University North, Koprivnica, Croatia, 648-656
32. Maslach, C., (2011). Wypalenie w perspektywie wielowymiarowej, in H. Sęk (ed.), *Wypalenie zawodowe. Przyczyny i zapobieganie* Warszawa: Wydawnictwo Naukowe PWN, 13-31.
33. Maslach, C., Jackson, S. (1981). The measurement of experienced burnout, *Journal of Occupational Behavior* 81(2), 99 -113.
34. Maslach, C., Schaufeli, W.B., Leiter, M.P. (2001). Job burnout. *Annual Review of Psychology*, 52(1), 397-425.
35. Massalski, M. (2012). Jak budować kapitał z Pokoleniem Y? Retrieved from: [http://www.networkmagazyn.pl/jak\\_budowac\\_kapital\\_z\\_pokoleniem\\_y](http://www.networkmagazyn.pl/jak_budowac_kapital_z_pokoleniem_y) (02.09.2017).
36. Ranking 100 najbardziej pożądanych pracodawców (2017). Retrieved from: <https://www.forbes.pl/kariera/najlepsi-pracodawcy-w-polsce-ranking-forbesa-za-2017-rok/15rp9v0> (17.11.2018)
37. Rapacz, A. (2007). *Przedsiębiorstwo turystyczne*, Warszawa: Wydawnictwo Difin.
38. Raport: *Student a pracodawca* (2017). Retrieved from: <http://www.egospodarka.pl/142461,Jak-miewaja-sie-studenci-na-ryнку-pracy,1,39,1.html> (24.07.2018)
39. Richardson, S., Butler, G., 2012, Attitudes of Malaysian Tourism and Hospitality Students' towards a Career in the Industry, *Asia Pacific Journal of Tourism Research* 17 (3), 262–276.
40. Richardson, S., Thomas, N.J. (2012), Utilising Generation Y: United States Hospitality and Tourism Students' Perceptions of Careers in the Industry, *Journal of Hospitality and Tourism Management* 19 (1), 102–114.
41. Schaufeli, W.B., Martinez, I., Marques-Pinto, A., Salanova, M., Bakker, A. (2002). Burnout and engagement in university students. *Journal of Cross-Cultural Psychology*, 33(5), 464-481.
42. Schlager, T., Bodderas, M., Maas, P., Cachelin, J.L., (2011). The Influence of the Employer Brand on Employee Attitudes Relevant for Service Branding: An Empirical Investigation, *Journal of Services Marketing*. 25 (7), 497–508.
43. Skrzyszewska K., Milić Beran I. (2016). Is Ignorance of Potential Career Paths a Disincentive for Starting a Career in the Maritime Sectors ?, *16th International Scientific Conference on Economic and Social Development – The Legal Challenges of Modern World* , ESD Conference, Split, 1-2 September 2016, 580 – 581.



44. Spodarczyk, E., Szelałowska – Rudzka K. (2015). Is Social Responsibility Required in the Cooperation Among Universities, Businesses and Local Government in the Local Environment? in: J.C. Dias Rouco (ed.), *Proceedings of The 11th European Conference on Management Leadership and Governance ECMLG 2015*, Academic Conferences and Publishing International Limited, UK, 437-444.
45. Teng, C–C. (2008), The effect of personality traits and attitudes on student uptake in hospitality employment, *International Journal of Hospitality Management*, 27 (1), 76–86.
46. Tokarz-Kocik A. (2017a). *Ryzyko motywacyjne w gospodarowaniu kapitałem ludzkim w hotelarstwie. Ujęcie ekonomiczne*, Wydawnictwo Uniwersytetu Szczecińskiego, Szczecin.
47. Tokarz-Kocik, A. (2017b). Inwestycje retencyjne w kapitał ludzki w hotelarstwie. Aspekty teoretyczne., *Prace Naukowe Uniwersytetu Ekonomicznego we Wrocławiu*, (473), 570-578
48. Tokarz-Kocik, A. (2017c). Wpływ zmian demograficznych na rynek pracy w hotelarstwie, In E. Biernat, E. Dziedzic (eds.), *Trendy w turystyce*, Warszawa: Oficyna Wydawnicza Szkoły Głównej Handlowej w Warszawie, 289-300.
49. Uludağ, O., Yaratana, H. (2010). The effect of burnout on engagement: An empirical study on tourism students. *Journal of Hospitality, Leisure, Sport and Tourism Education* 9(1), 13-23.
50. Weaver, A. (2009). Perceptions of job quality in the tourism industry. The views of recent graduates of a university's tourism management programme, *International Journal of Contemporary Hospitality Management* 21 (5), 579-593.
51. Wojtaszczyk, K. (2012). Employer branding, czyli zarządzanie marką pracodawcy. Uwarunkowania, procesy, pomiar, Łódź: Wydawnictwo Uniwersytetu Łódzkiego.
52. Yang, J.T., (2010). Antecedents and consequences of job satisfaction, *International Journal of Hospitality Management* 29(4), 609-619.
53. Yiu, M., Law, R., (2012). A Review of Hospitality Internship: Different Perspectives of Students, Employers, and Educators, *Journal of Teaching in Travel & Tourism* 12 (4), 377–402.
54. Zopiatis, A., Constanti, P., (2012). Managing Hospitality Internship Practices: A Conceptual Framework, *Journal of Hospitality & Tourism Education* 24 (1), 44–51.

## **CAN ORGANIZATIONAL CULTURE PREDICT DEVIANCE AT WORK: EXPLORING THE CAUSE EFFECT RELATION**

**Ana Aleksic**

*Faculty of Economics and Business, University of Zagreb, Croatia  
aaleksic@efzg.hr*

**Ivana Nacinovic Braje**

*Faculty of Economics and Business, University of Zagreb, Croatia  
inacinovic@efzg.hr*

**Sanda Rasic Jelavic**

*Faculty of Economics and Business, University of Zagreb, Croatia  
srsasic@efzg.hr*

**Lovorka Galetic**

*Faculty of Economics and Business, University of Zagreb, Croatia  
lgaletic@efzg.hr*

### **ABSTRACT**

*The concept of workplace deviance has been recognized to have a significant impact on various aspects of organizational activities. Being seen as a disruptive and costly organizational problem, many organizations strive to prevent and discourage this form of behaviour. Among others, managers seek to develop organizational culture that diminishes this negative behaviour and creates healthy environment, as organizational norms, values and attitudes can influence employee's behaviour. Still the question that raises is can all forms of cultures influence deviance at work and which specific forms of culture are best to predict and assure low levels of deviance. Through an empirical research this paper has shown connection among types of deviance, but although descriptive statistics showed differences in organizational and interpersonal deviance between groups of employees according to the dominant value orientation within their employer, such differences were not confirmed by non-parametric tests.*  
**Keywords:** *Deviant workplace behaviour, Organizational culture, Personality traits*

### **1. INTRODUCTION**

When it comes to organizational member behaviour and performance, it is possible to distinguish between three dimensions that define overall individual performance: work performance, contextual contribution and negative work behaviour (Robbins and Judge, 2013). Work performance relates to main employee activities and tasks in organization, contextual refer to all individual activities that contribute to organization, but are not included in basic work assignments, such as altruistic behaviour toward colleagues and other forms of organizational citizenship behaviour. Third dimension refers to negative, deviant behaviour that includes violation of organizational norms and threatens all organizational stakeholders. This sort of behaviour is known also as counterproductive work behaviour, antisocial work behaviour (Giacalone and Greenberg, 1997) or aggression on workplace (Baron and Neuman, 1998). Deviant behaviour implies behaviour that deviates from acceptable standardized norms that most members of a group or society accept and evaluate as desirable and binding. As opposed to other dimensions of performance, deviant behaviour is considered negative and undesirable. Many scholars who study workplace deviance have focused to analyze the possible antecedents of negative workplace deviance. These antecedents could be grouped into internal and external variables.

Internal variables refer to internal disposition and internal propensity forces that drive people toward certain behavior. On the other hand, external variables vary from workplace and organization factors to general environment factors. Martinko et al. (2002, p. 41) emphasize that deviance is considered to be “the result of a complex interaction between the person and the environment in which the individual’s reasoning about the environment and expected outcomes drive the individual’s behaviour. In the context of organization, environmental factors include situational and organizational factors (Marasi et al., 2018), where organizational culture is expected to have a significant role. In many studies it has been shown that organizational culture has an important role influencing positive and negative consequences within organizations. Managers seek to develop organizational culture that creates healthy environment, with none or low level of deviance. Still the question that raises is can all forms of cultures influence deviance at work and which specific forms of culture are best to predict and assure low levels of deviance. In order to understand the role of organizational culture and test the role of organizational culture as an organizational factor that can effect on emergence of deviance, this study is designed to explore the cause and effects of different types of culture on organizational and interpersonal deviant work behaviour. The paper is organized into several sections. After the introduction, the second and third section provide overview of deviant workplace behaviour, its causes and consequences but also specifically address organizational culture in relation to deviant behaviour. This is followed by the methodology and results part where empirical study is presented together with the main findings of the study. The paper concludes with a discussion of major findings and their implications, research limitations and possible future research.

## **2. DEVIANT BEHAVIOUR, ITS CAUSES AND CONSEQUENCES**

Deviant behaviour presents different forms of employee behaviour that harms the legitimate interests of the organization (Sacket et al., 2006). It is “a voluntary behaviour that violates significant organizational norms, and may be harmful to the organization or the people in the organization, including employees, clients or customers” (Robinson and Bennett, 1995, p. 556). Endangering not just the organization, but also its members it encompasses all activities of physical and verbal violence and intimidation at work. Different typologies have been created to explain workplace deviance. For instance Spector et al. (2006) propose five dimensions: abuse against others, production deviance and sabotage, theft and withdrawal. On the other hand, Gruys and Sackett (2003) created a typology of as many as 11 dimensions, namely: theft of property, destruction of property, misuse of information, misuse of time and resources, behaviour that causes insecurity, poor attendance, lack of participation, poor quality of work, use of alcohol, substance abuse, inappropriate verbal actions, inappropriate physical actions. However, one of the most accepted typologies is the one proposed by Robinson and Bennett (1995). On the basis of dimensions - minor versus serious and interpersonal versus organizational; these authors propose four distinct categories of employee deviance. Those are: (1) production deviance - includes behaviours such as: leaving early, intentionally working slowly, etc.; (2) property deviance - includes sabotage, stealing, taking bribes; (3) political deviance - includes showing favouritism, gossiping, blaming co-workers; (4) personal aggression - includes sexual harassment, verbal abuse co-worker theft, and endangering co-workers) (Figure 1).

*Figure following on the next page*

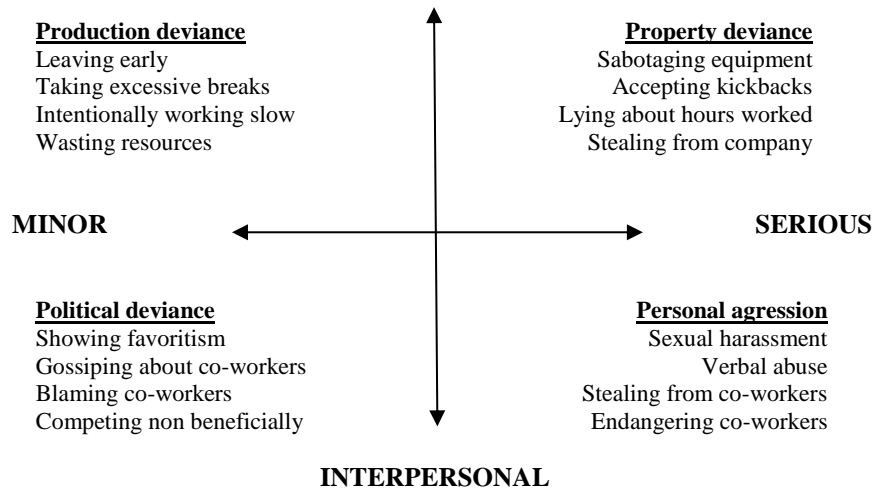

Figure 1: Typology of deviant behaviour (Robinson, Bennett, 1995, p. 565)

Many problems and costs are associated with deviant workplace behaviour. On organizational level, some of the problems that organizations face with as a consequence of deviance are: reduction in employee morale, negative impact on employee productivity and performance, creation of disruptive working environment, higher levels of absenteeism and fluctuation, slower work pace, reduced concentration at work, delays in deliveries, poor communication, loss of reputation, and similar (Applebaum et al., 2007). The consequences for individuals who are exposed to deviant behaviour by others, or who are victims of such behaviour can be for instance psychological and other health problems, anxiety conditions; the emergence of counter-aggression; job dissatisfaction; bad quality of private life, disruption of family and social interaction, use of drugs or suicide (Applebaum et al., 2007).

### 3. ORGANIZATIONAL CULTURE AS CAUSE OF DEVIANCE

Organizational culture presents a system of underlying values, beliefs, assumptions and principles that serve as a foundation for an organization's management system and define the way in which a firm conducts its business (Barney, 1986; Denison, 1990). It presents an implicit, invisible and informal element of the organization – and as some authors' state (e.g. McNamara, 2006) it presents organizational personality. Culture, through shared values and beliefs, conveys a sense of identity for organizational members, facilitates the generation of commitment to something greater than self, enhances social system stability and serves as a sense-making device that shapes employee behaviour (Smircich, 1983). Moreover, O'Reilly and Chatman's (1996) emphasize it is a social control mechanism that defines appropriate attitudes and behaviours for organizational members. Culture defines the context in which the relations among people develop and operate, providing basis for the implicit contracts that guide and shape decisions. In other words, it operates as a social motivation and control system (Roberts, 2007). It is a powerful lever for guiding organizational behaviour, as it functions as "organizational control mechanism", informally approving or prohibiting some patterns of behaviour (Ott, 1989). Deal and Kennedy (1982) articulated that successful firms distinguish themselves from less successful ones through their clearly articulated and shared norms and values regarding organizational functioning. Moreover, it is suggested cultural values either control or motivate deviant behaviour (Marcus, Schuler, 2004). Strong organizational cultures can support and acknowledge positive, as well as negative behavior influencing on rewards and recognition program (An and Kang, 2016) and barriers to progress. There are examples of organizational culture that support aggressive behaviors as a practical method of motivating employees, so, incivility and rude behavior may emerge if disrespectful behaviors persist (Valentine et al., 2016 referenced by Zeka, 2018).

Cameron and Quinn (1999) denote that an organization's culture is reflected by what is valued, the dominant leadership styles, the language and symbols, the procedures and routines and the definition of success that makes an organization unique. They propose a taxonomy of culture based on distinct culture types and their core values, namely the Competing Values Framework. This framework model uses two dimensions, vertical and horizontal, for disclosure of culture types. The vertical dimension differentiates flexibility, discretion and dynamism from stability, order and control, while the horizontal dimension differentiates internal orientation, integration, and unity (emphasis on people) from external orientation, differentiation and rivalry (emphasis on organization) (Cameron, Quinn 1999). Based on these two dimensions Framework allows for differentiation among four core culture types, namely Clan, Adhocracy, Market and Hierarchy culture types. Their characteristics are presented in the next figure.

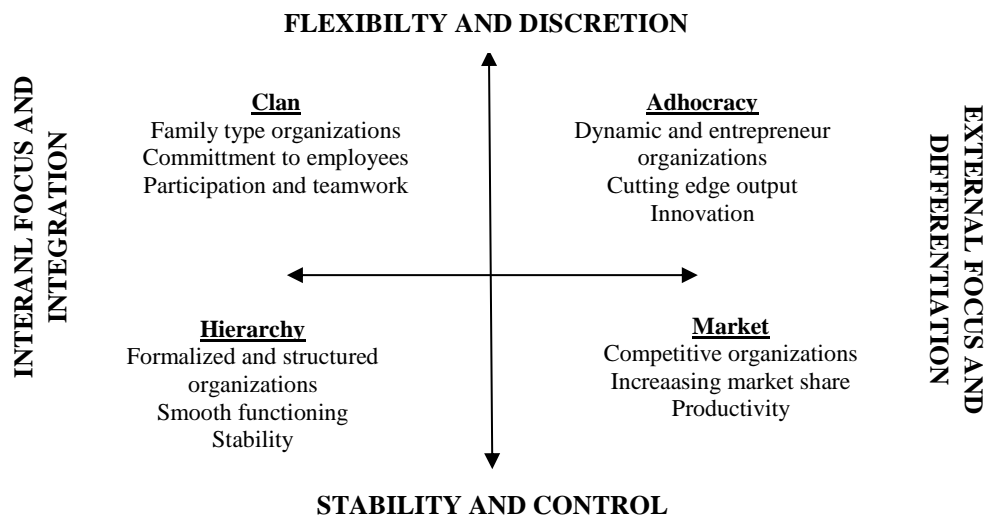

Figure 2: Competing values framework (Cameron, Quinn, 2011 referenced by Di Stefano et al., 2017)

As Pearson et al. (2005) emphasize, as organizational norms and values are brought through organizational culture, there is no reason to doubt that organizational culture and deviant employee behaviour will be interconnected. Still the question that rises is if all types of culture have the same connection with deviant behaviour. In other words, will different types of culture cause and have the same effect on the level of organizational and interpersonal deviant work behaviour.

#### 4. METHODOLOGY OF RESEARCH

In order to test the relation among type of organizational culture and different forms of deviant behaviour, a research model and questionnaire were developed. A self-reported anonymous questionnaire was used as a research instrument. It was designed based on previously well developed measurement scales referring to organizational culture and deviant workplace behaviour. Questionnaire consisted of three parts where first part of the questionnaire measured perception of organizational culture, second part was designed to assess presence of deviant workplace behaviour, while the third part included questions regarding respondents demographics (age, gender, educational level, years of work experience) as well as organizational characteristics (size, ownership, and industry sector). These demographic and organizational characteristics were used as control variables. Deviant workplace behaviour was measured with the 19 item scale developed by Bennett and Robinson (2000) measuring organizational and interpersonal deviant behaviour.

The scale consisted of two subscales, with first measuring interpersonal behaviour (7 items, statement sample: “Made fun of someone at work?”) and second measuring organizational deviance (11 items, statement sample: “Falsified a receipt to get reimbursed for more money than you spent on business expenses?”). Respondents were asked to indicate how often they have behaved in a way described by the statement using the scale from 1 to 7 (1 - never, 2 - once a year, 3- twice a year, 4 - several times a year, 5 -monthly, 6 -weekly, and 7 – daily). Based on these two subscales it was possible to compute a general score of deviant workplace behaviour. Organizational culture was measured with 16-item FOCUS questionnaire (based on Competing Values Framework). Items measure respondents’ perceptions of their organizational environments, and each item relating to one of the main values and accents of the four competing values models as presented previously. Respondents were asked to indicate the extent to which they agree that a certain behaviour is emphasized in their organization (sample item “Care for employees”) by using the scale from 1 to 5 (1 not at all, 5 - a lot). The reliability coefficient for all variables was higher than 0.7 indicating internal consistency of the scale’s items. Research was done on a sample of 86 participants that were recruited from 8 organizations. Sample was convenient as participants were recruited through a snowball sampling technique via personal and professional contacts of the researchers. As regard to sample characteristics 55,8% respondents were female, with average age of 35.7 (SD=8,3). 91,9% of respondents was with university degree and with average 1,8 years of working experience (SD=7.9). As regard to organizations they come from, 62,8% of organizations were large, 22,1% medium and 15,1% small. Organizations were mostly with public (57%) or private ownership (26,7%) and came from the field of education and public administration (57%). Data collected were analyzed using statistical software package SPSS 18.0.

## 5. RESEARCH RESULTS

When it comes to level of deviant behaviour, research results indicate low level of deviant workplace behaviour present among respondents. Descriptive statistics, including means and standard deviations for forms of deviant behaviour are presented in Table 1.

*Table 1: Descriptive statistics for deviant workplace behaviour*

Type of deviant behaviour	Min	Max	Mean	Std. Dev.
Organizational deviance (OD)	1,00	3,75	1,68	,605
Interpersonal deviance (ID)	1,00	3,14	1,50	,607

*N=86, Likert 1-7 scale*

As it can be seen, respondents indicate that they exhibited low deviance towards organization, as well toward others in organization. Male respondents as opposed to females report higher levels of both forms of deviance (OD  $\bar{x}$ = 1,75 vs. 1,63; ID  $\bar{x}$ = 1,56 vs. 1,45). When it comes to organizations, respondents from small organizations report highest level of organizational deviance ( $\bar{x}$ = 1,88); while respondents from medium sized organizations report highest levels of interpersonal deviance( $\bar{x}$ = 1,77). Highest levels of both forms of deviance are present in secondary sector (production, construction, engineering) and in private or mostly private owned companies. Results also indicate positive, statistically significant relationship among interpersonal and organizational deviant behaviour ( $r=0.62$ ,  $p<0,05$ ). When it comes to type of organizational culture, dominant value orientations among sampled companies are clan (20,9%), market (20,9%) and hierarchy (19,8%) culture. What is interesting is that almost 1/3 of employees indicated that the organization does not have a dominant value orientation, but a mixed one. In order to test the connection between the main variables we first checked for the level of deviant behaviour in organizations that were grouped according to the dominant type of organization culture, as presented in Table 2.

*Table 2: Level of deviant behaviour in organizations grouped according to the dominant type of organization culture*

Type	Organizational deviance $\bar{x}$	Std. dev.	Interpersonal deviance $\bar{x}$	Std. dev.
Clan (n=18)	<b>1,84</b>	0,77	1,6	0,67
Adhocracy (n=6)	1,73	0,43	<b>1,84</b>	0,83
Market (n=18)	1,59	0,48	1,44	0,62
Hierarchy (n=17)	1,58	0,50	1,37	0,47
Mix (n=27)	1,66	0,66	1,50	(0,59)

As it can be seen, respondents who perceive their organizational culture as clan, report highest level of organizational deviant behaviour, while respondents who perceive their organizational culture as adhocracy report highest level of interpersonal deviant behaviour. Lowest levels of deviance are presented in organizational culture perceived as hierarchy. Furthermore we tested for differences between groups with different dominant value orientations and levels of deviance. This was done by using non-parametric Kruskal Wallis test that allowed us to test if the difference between our four sets of samples (organizations) is statistically significant. We excluded respondents who perceived their organization to have a mixed value orientation. Table 3 and 4 show results for mean rank, as well as test statistics, where dominant culture was used as a grouping variable. Although our descriptive statistics implied possible difference in the level of deviance according to different type of organizational culture, unfortunately additional test did not show statistically significant difference.

*Table 3: Results of non-parametric test*

	Dominant culture	N	Mean rank
<i>Organizational deviance</i>	Clan (n=18)	18	32,69
	Adhocracy (n=6)	6	37,25
	Market (n=18)	18	27,86
	Hierarchy (n=17)	17	26,85
	<b>Total</b>	<b>59</b>	
<i>Interpersonal deviance</i>	Clan (n=18)	18	32,81
	Adhocracy (n=6)	6	35,00
	Market (n=18)	18	27,33
	Hierarchy (n=17)	17	28,09
	<b>Total</b>	<b>59</b>	

	<b>Organizational deviance</b>	<b>Interpersonal deviance</b>
Chi-Square	2,380	1,685
df	3	3
Asymp. Sig.	,497	,640

Additional analysis of data showed no statistically significant difference between organizations according to their size, type of industry sector.

## 6. DISCUSSION AND CONCLUSION

Organizational culture includes values and assumptions about social reality (Alvesson, 2002) and significantly influences individual behaviour. In this way it can be seen as an important element in governing the understanding of different individual behaviours, such as deviant one. The main purpose of this paper was to analyse and understand the relationship between types of organizational culture and organizational and interpersonal deviant workplace behaviour. For that purpose, an empirical research was done on sample of 86 employees from 8 different organizations. Results indicate that although descriptive statistics showed differences in organizational and interpersonal deviance between groups of employees according to the dominant value orientation within their employer, such differences were not confirmed by non-parametric tests. Our results did not indicate that distinct culture types and their core values will have different effect on level of deviance. In a similar research Di Stefano et al. (2017) however, did show that connection can be found between types of culture and deviance, with the adhocracy and clan cultures characterized by lower levels of deviant behaviour. Interestingly, however, results in general show low level of deviant behaviour, which in a certain way can imply that all types of culture are characterized by low deviance level, although a clear cause and effect relation can not be confirmed. Still, research results need to be seen in light of certain limitations. Primary, limitation refers to the number of respondents, as our sample represents a rather small sample. However, we need to stress this is a research in progress, so further efforts into having a bigger sample are present. Also, the question of respondent's subjectivity is present, as the paper tackled the subject of deviant behaviour. It is possible that respondents provided more socially acceptable answers, consequently results regarding level of deviance might be under impact of the questionnaire items used. Moreover, as deviance is under influence of distinct personal and environmental factors, organizational culture can not be analyzed as an exclusive factor influencing deviant behaviour. So further research needs to include additional individual and environmental variables into analysis. Furthermore, researchers also need to consider analyzing interaction among variables to get the complete picture regarding influences and different variables that can have cause and effect relation towards deviant workplace behaviour.

## LITERATURE:

1. Alvesson, M. (2002). *Understanding Organizational Culture*. London: Sage Publications
2. An, Y., Kang, J. (2016). relationship between organizational culture and workplace bullying among Korean nurses. *Asian Nursing Research*, 10(3), 234-239.
3. Applebaum, S. H., Iaconi, G. D., Matousek, A. (2007). Positive and negative deviant workplace behaviours: causes, impacts and solutions. *Corporate Governance*, 7(5), 586-598.
4. Barney, J. B. (1986). Organizational culture: can it be a source of sustained competitive advantage?. *The Academy of Management Review*, 11, 656-665.
5. Baron, R. A., Neuman, J. H. (1998). Workplace violence and workplace aggression: Evidence on their relative frequency and potential causes. *Aggressive Behavior*, 22(3), 161-173.
6. Bennett, R. J., Robinson, S. L. (2000). Development of a measure of workplace deviance. *Journal of Applied Psychology*. 85(3), 349–360.
7. Cameron, K. S., Quinn, R. E. (1999). *Diagnosing and Changing Organizational Culture*. Reading: Addison Wesley.



8. Deal, T. E., Kennedy A. A. (1982). *Corporate cultures: The rites and rituals of corporate life*. New York: Basic Books.
9. Denison, R. D. (1990). *Corporate Culture and Organizational Effectiveness*. New York: John Wiley & Sons.
10. Di Stefano, G., Scrima F., Parry, E. (2017). The effect of organizational culture on deviant behaviors in the workplace. *The International Journal of Human Resource Management*, Retrieved 19.08.2018. from <https://doi.org/10.1080/09585192.2017.1326393>
11. Giacalone, A., Greenberg J. (1997). *Antisocial Behavior in Organizations*. London: SAGE Publications.
12. Gruys, M. L., Sackett, P. R. (2003). Investigating the dimensionality of counterproductive work behavior. *International Journal of Selection & Assessment*, 11(1), 30–42.
13. Marasi, S., Bennett, R. J., Budden, H. (2018). The structure of an organization: does it influence workplace deviance and its' dimensions? And to what extent?. *Journal of Managerial Issues*, XXX(1), 8-27.
14. Marcus, B., Schuler, H. (2004). *Antecedents of counterproductive behavior at work: a general perspective*. *Journal of Applied Psychology*, 89, 647–660.
15. Martinko, M. J., Gundlach, M. J., Douglas, S. C. (2002). Toward an integrative theory of counterproductive workplace behavior: A causal reasoning perspective. *International Journal of Selection and Assessment*, 10, 36–50.
16. McNamara, C. (2006). *Field Guide to Consulting and Organizational Development: A Collaborative and Systems Approach to Performance, Change and Learning*. Authenticity Consulting, LLC.
17. O'Rilley, C. A., Chatman, J. A. (1996). Culture as social control: corporations, culture and commitment. *Research in Organizational Behavior*, 18, 157-200.
18. Ott, J. S. (1989). *The organizational culture perspective*. Chicago: Dorsey Press.
19. Pearson, C. M., Andersson, L. M., Porath, C. L. (2005). Workplace incivility. In S. Fox & P. E. Spector (Eds.), *Counterproductive work behavior: Investigations of actors and targets* (pp. 177–200). Washington, DC: American Psychological Association
20. Robbins, S. P., Judge, T. A. (2013). *Organizational Behavior*. New Jersey: Prentice Hall.
21. Roberts, J. (2007). *The Modern Firm, Organizational Design for Performance and Growth*. New York: Oxford University Press.
22. Robinson, S. L., Bennett, R. J. (1995). A Typology of deviant workplace behaviors: a multidimensional scaling study. *Academy of Management Journal*, 38(2), 555-572.
23. Sackett, P. R., Devore, C. J. (2001). Counterproductive Behaviors at Work. In N. Anderson, D. Ones, H. Sinangil & C. Viswesvaran (Eds.), *Handbook of Industrial, Work, and Organizational Psychology* (pp. 145-164). London: Sage. London.
24. Smircich, L. (1983). concepts of culture and organizational analysis. *Administrative Science Quarterly*, 28(3), 339-358.
25. Spector, P. E., Fox, S., Penney, L. M., Bruursema, K., Goh, A., Kessler, S. (2006). The dimensionality of counterproductivity: are all counterproductive behaviors created equal?. *Journal of Vocational Behavior*, 68(3), 446-460.
26. Zeka, L. (2018). *Organizational Culture and Individuals' Experience of Workplace Bullying* (Doctoral thesis). Walden University, Minneapolis.

## CREATIVE TOURISM AND RURAL DEVELOPMENT IN CROATIA

**Barbara Franic**

*University of Applied Sciences Baltazar Zaprešić in Zaprešić, Croatia*  
*bfranic@bak.hr*

**Danijela Grubisic**

*student of Juraj Dobrila University of Pula,*  
*Faculty of Interdisciplinary, Italian and Cultural Studies Croatia*  
*dgrubisic@unipu.hr*

### **ABSTRACT**

*Today's tourism is experiencing continuous growth caused by constant changes and the development of tourist needs. The reason for this is adapting to the needs and new demands of contemporary tourists who want to participate in every activity and learn about other cultures, ways of life and art practices. Creativity has always been a strong engine of human activities. In the areas of low socioeconomic status, its role is even more important for developing a life standard of rural area habitants. Creative tourism considers active participation in local creative activities, such as gastronomy workshops, harvests, learning traditional dances, songs and many more cultural elements. In order to keep a traditional lifestyle and keeping locals in their motherland, new management models should be brought together, including various sectors: tourism, culture, ethnology, spatial planning and agronomy. In a dynamic tourist market, with small investments, it is possible to create a competitive advantage based on the authenticity of a particular destination. This article presents a managing model on the example of Etnoland Dalmati at the hinterland of Dalmatia, Croatia, and the changes that have been made in that area.*

**Keywords:** *creative tourism, management of tourist destination, rural development, Republic of Croatia*

### **1. INTRODUCTION**

The challenges that the last economics crisis has brought to Croatia, such as strong structural problems (e. g. big rate of unemployment, devastated industries), are the most visible in rural areas of Croatia. In order to solve the existing problems, those areas must think about new models which would help them in regeneration and development. In the past years, tourism has been a strong engine that moves Croatian economics. Being complemented with a big potential of cultural sector, it can provide a wide range of solutions for economics and social problems. Starting from connecting communities and revitalising local culture, it can contribute to developing social capital, increase innovation, interest in investments and give new approaches to learning. Speaking of culture, there was a strong force in touristic demands aimed at intercultural experiences (for instance: visiting cultural events, museums, monuments) but complete touristic development full of traditional tourist attractions is not enough to satisfy the needs of contemporary tourists. Today's tourists are looking for new and entertaining experiences in which they will participate in order to learn a foreign language, traditions, gastronomy and history of a place where they came. Sightseeing is no longer seen as valuable but learning by participating is strongly wanted. Because of mass reproduction of cultural attractions and events that no longer satisfy the needs, many regions are rethinking new models and strategies for their development. More and more of them are trying to add additional value with diversity and animation of tourists, which includes creativity. Today, creativity is seen as a source of innovation and it represents discovering authentic locations through participating in all the activities of a community.

According to the theoretical framework and practical examples, creative tourism is travel directed toward an engaged and authentic experience, with participative learning in the arts, heritage, or special character of a place, and it provides a connection with those who reside in this place and create this living culture (UNESCO: Creative Cities Network, 2006). Based on this definition, we can determine the benefits of creative tourism for both - participants and the locals. Developing creative potential, getting closer to people, learning and making emotional and social bond, preservation of heritage are the benefits from the social perspective (Richards, 2012.). In the matter of rural development, some of the benefits are keeping family farms that provide local food alive, extending manufacturing possibilities, providing working places and making business conditions more positive, bigger tax and surtax contributions. Working in these terms, there is a special synergy coming to life and making space for new opportunities, growth and development: individual, social and economic.

## **2. CREATIVITY IN CROATIA – A THING OR A MYTH?**

While in more developed countries (such as Australia, UK and France who are known for being a “cradle” of creativity), creative tourism is being well known specific form of tourism, in Croatia its breakthrough is still on hold. In the past ten years, on the foreign markets, the created supply enables visitors to develop their creative potentials through participating in all kind of activities. The terminology followed these changes so today we use the term participants rather than those consumerism-oriented phrases such as consumers, buyers or visitors. The core of these changes is the content of today’s products (experiences). The focus has been put on a feeling and experience that is connected with the interpretation of values of a certain culture. Before, the focus was the object of interpretation, today, it is the audience that is the target. To be able to make a connection with a specific audience, heritage managers so as experience developers and designers, have to choose the right type of media to communicate. According to the Cultural Tourism Action Plan made by Institute for Tourism (2015.), by making a national strategy of cultural tourism, the idea about cultural/ creative tourism as independent touristic product for which the market and interest exists, became more popular. Another reason for perceiving this as an important sector is its multiplication effect of benefits for developing tourism, economic and social revitalisation. Other documents were accepted and put into action that represent a foundation for systematic and organized growth and development of touristic supply of this kind. A few of theorists and practitioners from Croatia (Daniela Angelina Jelinčić, Ana Žuvela, Elena Rudan) researched this subject matter through different forms of examination and came across similar conclusions. Jelinčić and Žuvela in their paper *Facing the Challenge? Creative Tourism in Croatia* (2012.) questioned the presence of creative tourism in two big touristic cities in Croatia: Zagreb and Dubrovnik. Their results were quite surprising; from 100 touristic agencies in Dubrovnik only one of them offered creative tourism experiences, for instance: local embroidery, folk singing and dancing. Zagreb, who has the biggest concentration of cultural and creative industries in the country (in the first row they are: music, film, architecture, theatre, design and dance), is not using its resources for branding and profit making. In the past years, some efforts were made in this sector. The local government, so as creative entrepreneurs and museum workers, made continuous efforts to make creativity a desirable skill that turns all the other important resources. The cultural sector became more aware of its own potential, creative workers and public started to understand these concepts and accept them and its development became a matter on all levels. Unfortunately, these cases are usually known in the bigger cities than in rural areas. Rudan (2012.) says that, towards making a creative touristic product, destination management is needed to run the entire tourism development. It should manage the activities that happen in the destination, provide continuity and quality of development, include locals in making and realisation of the offer, connect

tourism and cultural sector, ensure networking and education to associations, institutions and other relevant stakeholders that can be of great importance for the success.

### **2.1. Features of Croatian's rural territory**

With a rich, valuable, natural resources Croatia is one of the countries in the EU with the most kept environment. Good geographical position and three different types of climate have positively affected diversity of vegetable and wildlife. Unfortunately, rural areas are poorly inhabited and the trend of moving to more urban centres has been growing constantly. Because of this, population in Croatia has a dotted structure in rural and traffic-isolated parts such as Lika, Gorski kotar, islands and lately Slavonija. In the other hand, regions of the biggest cities in Croatia (Zagreb, Split, Rijeka) are having growth in population so their density is increasing. Demographic changes have been made under a strong pressure of destabilising factors (war and its aftermaths), transition problems in all matters of social and economic life. The biggest problems are losing government protection, destroyed infrastructure, decrease of production and productivity and in the end – losing competitiveness on the global market. (Čavrak, 2003.) Not recovering from all of it, exodus of a young and vital population is a shared problem in many rural areas. There is plethora of other problems caused by this. For example, contaminated and unkempt environment that is starting to worry many countries in the EU. Big social problems are noticeable in high social transfers to the habitants in those areas which is inactive in labour market. It represents big costs for the government and it makes entrepreneurs demotivated to take any business actions in those places (Čavrak, 2003.). These situations are leading generations of their inheritors addicted to poverty, leaving a big rate of unemployment for the country that is fighting crises for the last decade. Based on these acknowledgements, integral development is needed in order to keep habitants in their motherland and to make them aware of the possibilities that are existing. Contemporary need of stopping demographical and economical decrease of Croatian village so as solving accumulated problems and bad management, are listing rural development question in the first row of priorities of today's and future economic development of Croatia (Čavrak, 2003.). Putting together natural and heritage resources, creativity and tourism, a complete new scenery can be made. With those valuable factors, many activities can be established and bring working places, social security, perspective, prosperity and highly wanted recovery of Croatian rural areas.

### **2.2. New models of sustainable development (and what creativity has to do with it)**

Today, we prefer to think that the word crisis is something negative and hard to get out from. Rather than that, we could use it to describe a moment where we need to take an important decision such as thinking about rural areas as places of regeneration with comparative and competitive advantages that could make a major breakthrough on the touristic market. This belief is based on contemporary needs and lifestyle of today's consumers. After the last big economic crisis from 2008., research (EUROS RSCG) shown that consumers became more objective, responsible and more aware so they require the same from the suppliers. They do not want to take things fast anymore and they search for anything that is authentic and natural in order to experience culture of one society the best way possible. Goal of this movement is sustainable development of all segments of society. Based on this, we can highlight a few important today's trends: (1) high demand for untouched natural places, (2) interest for cultural events and places with cultural heritage where they can learn about local culture, but not through touristized events but from carefully designed, full of life and authentic events, (3) interest for healthy, organic food (The Institute for Tourism, 2015.). These needs are not being satisfied yet so there are large market opportunities where rural area habitants can start their business take off. Many rural areas in Croatia have everything that is needed for sustainable development: building and architecture traditions, craft skills, traditional art crafts, traditional songs and

dances, gastronomy gems (Čavrak, 2003.) All of these preserved tradition elements that could be brought together in one cultural-touristic product that is involving participants and “asking” them to discover Croatian culture. According to Richards (2002.), creative tourism includes a wide range of activities such as music, drama, languages, gastronomy, and they have major advantages that can relate to rural development. Creativity is making added value much easier because of its rareness; hence creative tourism can develop faster than any other kind of tourism because destinations can innovate their products keeping their position above the others. Creativity is a process and it can be renewable, creativity is mobile and doesn't stick to other cultural resources. In addition to this, creative tourism can bring recognition and better market position especially to those places with a lack of cultural heritage. There are several reasons why rural areas should accept this new model (Rudan 2012., according to Richards 2002.): (1) tourism requires investments in infrastructure that are often expensive, but most of them are bringing benefits to the local community and the business sector, (2) doing tourism activities and their promotion on other places is branding the area that helps economic improvement, (3) people that moved away will start to come back once they see their own interest, moving out will be stopped or slowed down, (4) growth of economic activities that are somehow related to the tourism (traffic companies, receptive facilities, special tours), (5) developing contents for attracting tourists will change mind of business people and managers thinking that it is suitable for working and living, (6) having tourists and promoting local culture positively affects habitant's pride, makes them keep their traditions and beliefs better.

### **3. BIG IMPACT OF A SMALL SECTOR – CROATIAN EXAMPLE**

One of the most visited tourist attractions in the hinterland of Dalmatia is Etnoland Dalmati. Its name could tell that it is rural tourism-based, but in fact it is so much more than that. This is an example of the first thematic park of this kind in Croatia. Through personal experience, participants can meet the life of Dalmatian hinterland as it once was: its traditions, folk dance, gastronomy and the way of life. The story behind it is likely extraordinary. Born in Germany with Croatian roots, this entrepreneur decided to bring back the life to this vacant land. Based near the city of Drniš (in Šibenik-Knin County), whose population decreased in half during a period of twenty years (1991. there was 14.773 inhabitants while in 2011. only 7.498), its role is getting bigger and bigger. Starting from the fact that it is employing habitants from that rural area, to the fact that they take care for more than 40.000 visitors in one year. The economic effect is seen in the financial inflows of the company (a profit of 267 thousand euros per year), city of Drniš through local taxes and the people who earn from selling local products or offer the apartment service. Social benefits are numerous; from maintaining local culture alive, teaching new generations of local kids about their culture, developing social capital, sense of a place, and making a strong connection to the Šibenik-Knin County identity. Knowing their target market and the trends that are spreading, Etnoland Dalmati is servicing the food from local farmers in order to please the demand of healthy organic food that the new generations are asking for. It is not the only example of creation that they have done; noticing the changes of being fed up with *touristized events*, they created authentic experience of a traditional folk dance, presentation of the whole complex and eating the specialties from the region. Etnoland Dalmati has really thought of everything – it is the first example of a solar power plant in Šibenik-Knin County and the first one that had an electrical car. They go for sustainability or nothing, pleasing all the goals of cultural-creative tourism: pleased participants, clean and protected nature, and economical benefits. Recognizing their good projects, they got financial support several times from the EU programme aimed at regional development and Croatian Ministry of Entrepreneurship and Crafts. Not only that they recognized their efforts: Etnoland Dalmati got many awards and prizes for the best touristic supply in the county and Croatia

(2012.), award for the best cultural heritage interpretation (2016.) and the best cultural heritage interpreter (2016.)

#### 4. CONSLUSION

Because of globalisation and hyper-consume society that is equalizing all of the cultural forms, the need of authentic, unique and different destination is showing like an antithesis to the mass tourism. Tourists no longer want to walk on the beaten tracks, they desire creative approach in the interpretation of a cultural attraction and the destination overall. Creative tourism is requiring optimal destination management and integration of all stakeholders in order to make content that will please contemporary tourist's needs. Research show that Croatia has all the needed resources that could be valorised in touristic purposes. Croatia's rural areas have good predispositions for having a wide range of cultural and creative experiences. Rich cultural heritage: traditions, traditional crafts, singing and dancing is just one of the reasons why to invest and develop this type of tourism. It helps local community to care more about its identity, it is having a big influence on employment, learning and making a social cohesion. The shown example supports these facts.

#### LITERATURE:

1. Čavrak, V. (2003.) *Održivi razvoj ruralnih područja Hrvatske*, Zbornik Ekonomskog fakulteta u Zagrebu, godina 1. broj 1., Ekonomski fakultet u Zagrebu, Acta turistica nova, Vol.3 No.1
2. Drucker, P. (1993.) *Managing in Turbulent Times*. New York: Harper & Row.
3. Franić, R. (2006.) *Politika ruralnog razvitka – nova prilika za Hrvatsku*, Agronomski glasnik, Hrvatsko agronomsko društvo, Zagreb
4. Jelinčić, A., Žuvela, A. (2012.) *Facing the Challenge? Creative Tourism in Croatia*, Journal of Tourism Consumption and Practice Volume 4 No. 2., University of Plymouth
5. Kombol, T. (2006.) *Kulturno nasljeđe i turizam*, Radovi Zavoda za znanstveni rad HAZU Varaždin, br. 16 – 17, Zavod za znanstveni rad Hrvatske akademije znanosti i umjetnosti u Varaždinu, Varaždin
6. Richards, G, Marques, L. (2012.) *Exploring Creative Tourism: Editors Introduction*, Journal of Tourism Consumption and Practice Volume 4 No. 2., University of Plymouth
7. Richards, G. (2009.) *Creative tourism and local development*, Wurzburg, R. Pattakos, A. and Pratt, S. (eds) Creative Tourism: A global conversation, Santa Fe: Sunstone press
8. Rudan, E. (2012.) *Razvojne perspektive kreativnog turizma Hrvatske*, Ekonomska misao i praksa god XXI, br. 2., Sveučilište u Dubrovniku, Dubrovnik

## ANALYSIS OF ROAD FREIGHT MARKET IN CROATIA

**Dora Naletina**

*University of Zagreb, Faculty of Economics and Business, Croatia*

*dora.naletina@efzg.hr*

### **ABSTRACT**

*Road transport has crucial role for the development of any society, and a well-planned infrastructure is one of the key prerequisite of economic growth. Road transports connects production and final consumers so it is essential for adequate functioning of any economic systems. Road transport occupies the leading role in the entire transport by land in almost all countries of Union, and Republic of Croatia is not an exception. The purpose of this paper was to underline basic characteristics of road freight market in the Republic of Croatia. It is a highly fragmented industry and due to that there is no company which could significantly influence the industry's profitability, as it is consisted of a large number of small companies. Most Croatian transporting companies have small vehicle fleets (up to 5 vehicles) with a poor average age structure. It is necessary to encourage alliances between Croatian road freight transportation companies, through clusters or associations, in order to operate together internationally and domestically. Despite the fact that in the Republic of Croatia, a few clusters have been operating for years now, their role is still marginal. Main problem is that most of Croatian road transporters are still not aware how alliances would influence their operations and make business dealings easier and more successful, both on the domestic and international market.*

**Keywords:** *road freight, Croatia, vehicle fleets, clusters, associations*

### **1. INTRODUCTION**

In most countries, road transport occupies the leading role in the entire transport by land. In Croatia, and all the countries of the European Union, the transport of goods by land plays a key role in almost all economic activities, those crucial for infrastructural and socio-economic welfare in particular. Road transport is essential for the development of any society, and a well-planned infrastructure is one of the key prerequisite of economic growth (Ivanova and Masarova, 2013: 263). All economic systems rely on road transport because it connects production and final consumers. However, although road transport brings many benefits to the society, it also implies certain costs regarding pollution. The Republic of Croatia, if we are to regard land transport in particular, was up until the 1980s quite marginalised. The most successful exporting company in the former state was in Slovenia, while Croatia had only few transporting companies operating abroad. Opportunities for full-fledged activities in the field of private business had opened not until Croatia became an independent state, but then the state of war largely influenced further development. Today, Croatian transporting has reached high levels of compatibility with other European transporters. The possibility of achieving permanent and stable lines of business is conditioned by upgrading the existing activities, application of modern processes and procedures and professional education of staff which directly provides transporting services (Banelli, Kolak and Vukadinović, 2009). The aim of this paper is to underline basic characteristics of Croatian road freight market. Due to that it will be analysed age structure of vehicle fleets, concentration in Croatian road freight industry, as well as clusters and associations of road freight transporters.

### **2. LITERATURE REVIEW**

The overview of domestic literature shows that there are very few papers that give focus to road transport. Also, many of those few works analyse road transport market regulative in the

Republic of Croatia. On the other hand, foreign literature provides many works that study road transport industry, and many emphasize the analysis of the road transport impact on the environment, the influence of information technologies on road transport, competitiveness of road freight transporters, development of road transport and measures for increasing road transport safety.

### **2.1. Literature review of domestic research**

Naletina (2016) was investigating sources of competitive advantage in Croatian road freight industry. In the research, a new approach has been used– the resource-based approach, to analyse sources of competitive advantages in Croatian road freight industry. The resource-based approach states that resources of a company are dominant in setting its strategy, and that they are crucial in creating sustainable competitive advantage. Based on the findings of the primary research, it can be concluded that road freight companies, if they want to become more significant players on the international market, have to invest more in the quality of information systems; routing systems, communication with the drivers, Track & Trace systems and devices in the vehicle intended for tracking the parameters of the vehicle, the conditions and the freight temperature. Furthermore, companies have to commit to the quality of the employees who are crucial for competitive advantage. Likewise, the companies with a high number of hired vehicles in the fleet should differentiate their services. They should offer additional services like storage, cumulative transport, repackaging, labelling, filling out the documentation and involvement in the specific production phase. The companies with higher number of their own vehicles in the fleet should focus on the staff differentiation and in that way try to build their competitive advantage. Rajsman and Rođak (2015) conducted a research on the importance of a tachograph in the work of road traffic inspections and in the prevention of road accidents. Tachograph is irreplaceable for monitoring the work of the drivers in road transport, and the paper analyses the characteristics of the analogue and the digital tachograph. The authors emphasize that the contribution of the tachograph records is not only seen in the monitoring of drivers' work, complying with the regulations regarding the working hours and mandatory rests during the work day, but also in significant possibilities of traffic accident prevention. Vukadinovic, Tomasović and Kolak (2014) analyse the properties of international road freight traffic market, with the accent put on the analysis of the quality of the road freight transporters fleet in Croatia. They point out that, in Croatia, average age of Croatians companies' fleet registered for road freight transport is extremely high and that is why they cannot compete on the EU market, and most Croatian companies have only a few heavy goods vehicles. This is very discouraging, especially when considering the fact that certain countries charge higher tolls for older vehicles, which further complicates the possibility of achieving competitive advantage. Šolman (2010) analyses the role of road traffic in the development of Croatian tourism. The author points out that the former transport policy of unequal development of the transport system cannot ensure high-quality logistical support to tourism in the future. This unequal development has made road transport develop rapidly, in particular through the construction of transport infrastructure facilities, while other branches of transport have stagnated. The author concludes that well-organized and well-planned traffic, particularly at the micro level of a tourist destination, is an additional guarantee of its touristic attractiveness. Only a uniform development of all traffic branches in the system can enable a quality and efficient logistical support for tourism and for strategic economy in Croatia. Radionov Radenković (2006) investigated road freight transport market in Croatia starting from the premise: do the roads lead to the European Union? The paper analyzes the structure of Croatian road transport law regulations before and after the implementation of the procedure of coordination with the European Union regulations. The conclusion highlights the fact that it is obvious that the coordination of road transport legislative focused more on meeting the set deadlines, and not so



much on realization of short- and long-term transportation goals. Botrić, Šišinački and Škuflić (2006) conducted a case study on Croatian road infrastructure and regional development, by analysing the influence of the Istrian Y motorway on the development of the County of Istria. Owing to the analysis of statistical data, the authors conclude that positive effects of the Istrian Y motorway are unquestionable. Istrian Y motorway has directly contributed to the reduction of the vehicle operating costs because the distances have been shortened. Building of the new motorway has contributed to the significant reduction in the number of traffic accidents. Also, the authors confirmed that building of this motorway has had an impact on the employment, especially within the construction sector. Furthermore, the authors confirmed a positive interaction of better accessibility through motorway network and tourism.

## **2.2. Literature review of international research**

Ncube, Roberts and Vilakazi (2015) conducted a study of competition in the road freight sector in the SADC region – the case study of fertilizer transport and trading in Zambia, Tanzania and Malawi. The authors remarked that competition, market structure and arrangements among the firms in the road freight sector – as well as the relationship between road freight operators and large importers – play an important role in determining the price and trade of commodities among the countries. They concluded that competitive outcomes in road freight in the context of fertilizer trading are driven by the inter-relationships between large transporters and users of the transport, cross-border rivalry, and both small and large regulatory interventions to enhance the outcomes in road transport. Based on the results of their research, for improvement of road freight transport, they recommend the following: careful monitoring of fertilizer prices; increased co-operation between competition authorities in SADC, fast-tracking the implementation of pro-competitive regulation affecting road transportation, considering the effect of fertilizer subsidy programmes on competitive outcomes and removing the recommended transport prices in Malawi. Evangelista and Sweeney (2014) examined the application of information and communication technologies in road freight transport industry in Italy. Based on the findings, they conclude that mobile phones have reached a high level of penetration as a communication mechanism with the drivers, since almost 90% of the drivers confirmed that their entire fleet is equipped with mobile phones. However, 38.5% of the companies still do not have a web site and do not use the Internet as the tool for more efficient business transactions, which proves the neglecting of technology in transporting companies. In order to increase the efficiency and reliability and remain competitive on the market, road freight transporters have to continually develop innovations. Information and communication technology still represents one of the most significant innovation areas. The authors state that the advantages of the use of ICT applications relate to better planning and more optimal driving schedule, better tracking of the goods and the vehicle, faster transportation operating as the result of a more effective data gathering and analysing, improved transaction documentation and a higher level of coordination and integration among different road transporters and the participants in the supply chain. They also point out that small road transporters still see information and communication applications as an expensive investment. Demir, Bektas and Laporte (2014) conducted a systematic review of 58 publications that mainly focus on green road freight transportation. An extensive analysis of factors affecting fuel consumption and routing problems with fuel consumption components have also been investigated. Streimikiene, Baležentic and Baležentiene (2013) conducted a comparative assessment of road transport technologies. They tried to assess energy technologies in road transport sector regarding the atmospheric emissions and costs, and also, to indicate the most competitive and environmentally friendly transport technologies. The authors point out the concerning increase of greenhouse gas emissions in the traffic sector, while in other sectors, reductions are recorded.

They state that greenhouse gas emissions can be reduced by using hybrid electric vehicles; by using low-carbon fuel, like bio ethanol or bio diesel; by substituting a share of oil with electrical energy used in plug-in hybrid vehicles and by improving road infrastructure and better managing traffic with applying intelligent systems more. Fiscal measures play important role in ensuring the stability of the public finance, but they can also have significant impact on CO<sub>2</sub> emissions from the traffic. They can also lead to reducing CO<sub>2</sub>, for example through enticing production and buying of green vehicles and encouraging more efficient fuel consumption. In their paper, Litschke and Knitschky (2012) also analyse future development in road freight transport regarding more environmentally friendly vehicle technologies. Monitoring the pollution caused by the transport of goods occupies an important place in most national, but also European development policies over the last years. The authors emphasize that, in order to achieve the goals from the White Book which relate to the year 2030, it is necessary to develop more efficient technologies and alternative fuels that will help significantly reduce CO<sub>2</sub> emissions. Matos and Silva (2011) investigated the rebound effect in road freight transport in the case of Portugal. They analysed the data from the road freight transportation sector in Portugal from 1987 to 2006. It was determined that an increase in energy efficiency did not cause a backfire, but did cause a total direct rebound effect of 24.1%. In addition, fleet operators were more inclined to adopt operational efficiency than technological fuel efficiency as a means of increasing the total operational efficiency. McKinnon and Piecyk (2009) investigated the measurement of CO<sub>2</sub> emissions from road freight transport based on the UK experience. The authors suggest that, over past few years, many transporters whose primary activity is road transport, have been expanding their assortment by providing the services of storage. Also, the authors point out that there are big differences among the national road freight industries regarding the share of transport activities outside the country's borders. Lazauskas et al., (2012) investigated competitiveness among the road transport companies in Lithuania. Based on the findings, they state that most companies give most attention to price, delivery time and safety. Only those companies that transport smaller amounts of goods pay attention to the marketing strategy, while larger companies commit more to the properties of the services and the resources. If international freight transport is observed, the consumer gives advantage to those companies that own their own freight vehicles. If road freight transporting companies wish to attract more clients, they should, first and foremost, continually improve on the reliability of the service and company's reputation. Marchington, Carroll and Boxall (2006) investigated the issue of the lack of the work force in road freight transport industry and its influence on small companies, and for the purpose of the research, they made a modified version of the resource approach to the company. Drawing on longitudinal data from seven small road companies, we think that owners-managers have developed an astute combination of socially complex networking abilities. These abilities relate to an extensive understanding of both product and local labour markets. We conclude that the RBV (resource-based view) needs to be extended, so different ownership goals and diversity on the markets can be realised, and the forces that promote similarity rather than differences among the firms within the industry can be considered.

### **3. CHARACTERISTICS OF CROATIAN ROAD FREIGHT MARKET**

Road freight industry includes transportation of freight between the companies and between companies and consumers (Boyluad and Nicoletti, 2001: 230). Analysis of land transport in the EU by mode of transport reflects that road transport has crucial role and its share in 2016 was 72.8% (European Commission, 2018: 36) If transport by land (in tonne kilometres) in Croatia is observed, then it can be seen that since the establishment of the country, road transport has had a dominant role. In 2016, its share was 69.75% (Croatian Bureau of statistics, 2017: 352) and more than 22.000 people have been employed in 5.478 road freight transportation

companies in Croatia (European Commission, 2018: 24-25). The average number of employed persons in Croatian road freight companies in 2015 was 4.03 persons, while the average of EU-28 was 5.36 persons.

### 3.1. Analysis of road freight vehicle fleets

Croatian road transporting industry is mainly based on small companies, most of which own a vehicle fleet of less than 5 freight vehicles. The concerning fact is that road transporting companies in Croatia possess motor parks whose average age are pretty high in relation to the average age of vehicle fleets in other EU member states. When taking into consideration that in most EU members toll roads are more expensive for older vehicles, this fact certainly contributes to the decrease in competitiveness of Croatian road transporters. While the average age of our vehicles in 2012 was 12.9 (Vukadinović, Tomasović & Kolak, 2014: 63), in the EU-28 only 16% of road freight vehicles were more than 10 years old.

Figure 1: Structure of road freight transport by age of the vehicle in EU-28

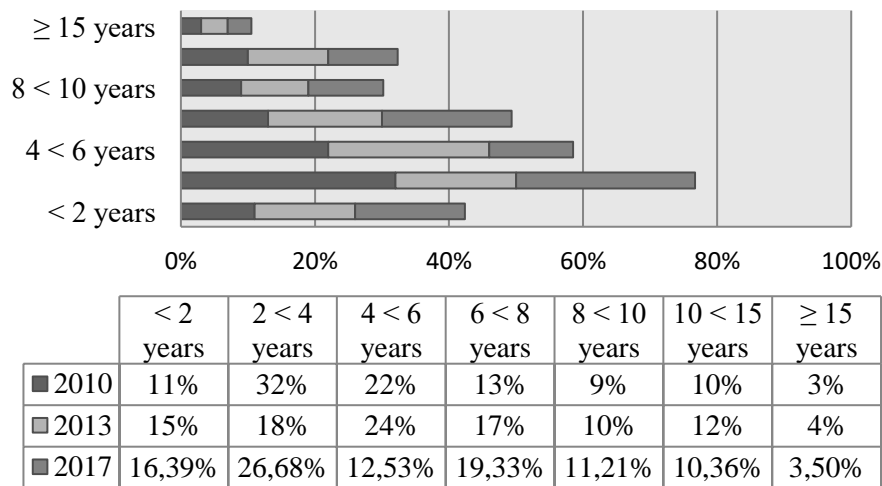

Source: author-compiled according to the European Commission data (2018) Road freight transport by age of vehicle, EU 28, 2013-2017. & European Commission DG for Mobility and Transport (2011). Road freight transport vademecum 2010 Report, p. 18.

Furthermore, Figure 1 shows that in 2013, more than half of the EU road freight transporters had vehicle fleets not more than 6 years old. If we are to compare the value of a vehicle fleet which is more than 10 years old, it can be concluded that in 2013, their share increased by 3 percentage points. If we are to observe the structure in 2017, then it can be seen that 55.6% of freight vehicles in EU were not older than 6 years. Also, there is the positive reduction of the share of the vehicles that are older than 10 years, the share being 13.86%, which is by 2.14 percentage points less than in 2013. Road transporters within the EU use newer vehicles more in the international than domestic freight transporting. Newer vehicles pay much lower tolls for having reduced environmental impact (European Commission, 2014). In order for the transporters even to consider the decisions about the fuel cost rationalization, they need to have a good method of tracking the vehicle fleet's activities, along with presenting all necessary reports. Objectively, the bigger the transporting company, the bigger the possibility of inhomogeneous vehicle fleet based on several parameters (type of the vehicles, shape of the vehicles' body, set bearing capacity, age of the vehicles, the level of ecological quality), which further complicates the decision-making regarding the fuel costs (Banelli, Kolak and Vukadinović, 2009). If we observe the share of the registered road freight vehicles in the total number of registered road freight vehicles, we can notice a problem in the concentration of road

transporters in the county of Zagreb, where there are more than 28.08% of the registered road freight vehicles (Croatian Bureau of statistics, 2017: 367).

*Table 1: Registered and first time registered road freight vehicles in Croatia, 2003 - 2016*

Year	Total registered	First time registered road freight vehicles	Share of first time registered in total number of registered road freight vehicles
2003	138.290	<b>14.307</b>	10,35%
2004	144.635	12.598	8,71%
2005	152.663	12.650	8,29%
2006	159.147	13.607	8,55%
2007	165.742	13.782	8,32%
2008	<b>170.704</b>	13.148	7,70%
2009	164.761	6.780	4,12%
2010	157.731	4.996	3,17%
2011	154.884	5.198	3,36%
2012	141.567	5.218	3,69%
2013	141.491	7.272	5,14%
2014	143.660	8.395	5,84%
2015	149.006	11.212	7,52%
2016	146.230	13.210	9,03%

*Source: drawn up by the author based on the Croatian Bureau of statistics (2013). Statistical Yearbook of the Republic of Croatia 2013, p. 349 & Croatian Bureau of statistics (2017). Statistical Yearbook of the Republic of Croatia 2017 p. 356*

Table 1 shows the total number of registered road freight vehicles in the Republic of Croatia and total number of first registered road freight vehicles in the period from 2003 to 2016. It can be seen that the highest number of first registered road freight vehicles was registered in 2003, when there were 14.307 of the first-time registered road freight vehicles. Since then till the end of 2010, registering was declining. In 2010, just 3.17% of registered vehicles were those vehicles that registered were registered for the first time. On the other hand, the positive side is that in the last few years, the number of the first-time registered road freight vehicles has increased, while being almost stagnant from 2009 till 2011. In 2016, the share of the first-time registered vehicles was 9.03%, which represents high increase in relation to 2010 but it is still by 1.32 percentage points lower than the share in 2003.

### **3.2. Croatian road freight transporters' alliances**

#### *3.2.1. Road freight transporters' clusters*

Clusters are key drivers of workplaces, payrolls, new business formations and innovations and they characterize modern economies (Porter, 2003). They are concentrations of entrepreneurs, suppliers, specialized institutions and producers of related products which emerge in particular industries in certain cities or regions. Clusters often include various products and services and combine industries in different regions, opposite to traditional industrial systems (Porter, 2009). Globalization has further increased the importance of clusters. There are fewer barriers for entry and more space for competition, which enables faster growth of the existing clusters (Porter, 2003). Clusters are economic alliances with the aim of raising competitiveness, they are not associations. They are companies which operate independently with all the elements of the market game and are easier to understand if interpreted as partnerships (Laslavić, 2008).

Efficient transport and equally efficient logistics activities are initiators of faster economic growth. For that purpose, organizational groups – clusters are established. They join companies and institutions from the fields of transportation, shipping agencies, ports, ecology and higher education (Banelli, Kolak and Vukadinović, 2009). Competition among the companies in developed economies is lead by knowledge and skills. Clusters are important, for they play a key role in creating knowledge, innovations, accumulation of skills and connecting employees. They are important because they encourage companies to change their vertically integrated structure (most activities are performed internally) into a structure characterized by a large amount of externalized activities and functions left to external subjects (Porter, 2009). Porter (2009) points out that clusters are convenient in industries characterized by a great number of competitors, and this exactly is a feature of Croatian road freight industry.

*Table 2: Clusters of transporters in Croatia*

<b>Name of the cluster</b>	<b>Year of foundation</b>	<b>Headquarters</b>
Šibenski prijevoznici	2002	Šibenik
Klaster istarskog transporta	2007	Tupljak
Jadranski prijevozi	2008	Split
Klaster Varaždinskih prijevoznika	2008	Varaždin
Klaster transportni centar	2009	Slavonski Brod
Cestovni prijevoznik - logistika	2007	Zagreb

*Source: drawn by the author based on the data gathered*

A cluster needs to offer its members informational support and technical communications, promotional support, organization of presentations on business meetings, cooperation with the government apparatus, identification of potential business partners, consulting when making business offers, quick access to market information, information on goods in ports and distribution centres and joint access to big business deals. In all, a cluster offers better participation in the entire process of transport services market with logistical support, a higher level of specialization and standardization, a better flow of information and knowledge, thereby enabling better business results for all members of the system (Banelli, Kolak and Vukadinović, 2009). As a rule, companies within a cluster operate more efficiently, share knowledge and technology, they are more flexible, easier engage in new activities and implement innovations faster (Porter, 2009). In the Croatian road transport sector, there are only six clusters (see Table 2). Cluster of Šibenski prijevoznici (Transporters of Šibenik) was founded in 2002 with the initial goal of combined activities of grouped transporters towards the Tvornica lakih metala (Light metals factory) in Šibenik, and later on, it even developed cooperation with the transporting clusters from other EU members (Laslavić, 2008). In 2007, twelve transporting companies founded the cluster of Istarski transport (Transport of Istria), with the aim of increasing competitiveness and better adjustment to market demands. Cluster Jadranski prijevoznici (Adriatic transporters) was founded in 2008 in Split with the goal of establishing an agency which would distribute operations to the members of the cluster. The cluster of Varaždinski prijevoznici (Transporters of Varaždin), unlike other clusters, offers the services of storage together with the services of organized transportation. With the aim of developing a logistics and distribution centre in Slavonski Brod, through networking of road, railway and river transport, the cluster of Transportni centar (Transportation centre) was founded. It joins companies directly or indirectly connected to transport (not road transport exclusively) and distribution of goods.

Cestovni prijevoznici-logistika cluster (Road transporters-logistics) is the only cluster out of the above mentioned which does not operate regionally, but joins Croatian transporting companies with the aim of better informational connectedness and the control of the surplus goods.

### 3.2.2. Croatian road transporters' associations

First and foremost, associations of transporters have to be competent and economic interests groups, as well as non-profit and non-governmental institutions, while representing global interests of all of their members. When forming an association, the founders need to have a common platform which would bring together all members. Globally, those goals are as follows (Banelli, Kolak and Vukadinović, 2009):

- Improving and promoting transporting activities.
- Representing interests of all members, both home and abroad.
- Protecting interests of the members when dealing with economic, political and governmental institutions which monitor the transporting industry.
- Preventing unfair competition.
- Providing flow of legal and commercial information and informing all members on time.
- Assisting in dealing with professional problems connected to transporting and providing legal protection.
- Laying down the code of professional ethics and resolving issues between the members through the Court of Honour.
- Correlating with other related international associations and cooperating with the European associations and organizations.
- Operating in line with the Article of the association and other existing regulations.

Existing associations of the road transporters in Croatia are:

1. DALCEST - Dalmatinska udruga prijevoznika (headquarters: Split),
2. HAP - Hrvatski autoprijevoznici (headquarters: Split),
3. HCP-GIU Hrvatski cestovni prijevoznici - gospodarsko interesna udruga (headquarters: Zagreb),
4. HUP Hrvatska udruga poslodavaca - Udruga prometa (headquarters: Zagreb),
5. TRANSPORTKOMERC - GIU Gospodarsko interesna udruga cestovnih prijevoznika (headquarters: Zagreb) and
6. UHCP - Udruga hrvatskih cestovnih prijevoznika (headquarters: Varaždin).

The main problem of the Croatian road freight transporting industry is that every company works for its own interests and speculates ways of getting benefits without cooperating with others. Furthermore, road transporters see obligations as oppressions, and that which is voluntary, they perceive as something they need or do not need. A heterogeneous scene of Croatian transporters' alliances will be weak and inefficient until they realize that professional services, dealing with protection of Croatian road transporters' interests on a global scale, have to be paid for their work (Banelli, Kolak and Vukadinović, 2009).

### 3.3. Industrial concentration in Croatian road freight transport industry

An industry is a group of companies with common features, while industrial structure is possible to be differentiated by the level of their concentration. This level of concentration is an important structural industry variable. As a rule, a greater number of companies is a feature of a non-concentrated industry, while a smaller number of companies characterize a concentrated one (Tipurić, Kolaković and Dumičić, 2003). A fragmented industry has more companies with lower concentration and a lesser influence on economic flows.

On the other hand, a consolidated industry implies that leading companies increasingly influence the industry's profitability (Tipurić, Pejić Bach and Pavić, 2008).

*Table 3: Leading companies registered for road freight transporting in the Republic of Croatia according to total turnover in 2017*

<b>Ranking</b>	<b>Name of the company</b>	<b>Turnover(kn)</b>	<b>Share in the total industry's turnover</b>
1.	ORAO Ltd.	263.617.854	2.48%
2.	RICARDO Ltd.	231.728.600	2.18%
3.	MANŠPED Ltd.	231.728.600	2.18%
4.	AGIT Ltd.	176.453.886	1.66%
5.	LA LOG Ltd.	174.327.936	1.64%
6.	RALU LOGISTIKA Ltd.	162.635.208	1.53%
7.	KOS TRANSPORTI Ltd.	146.690.580	1.38%
8.	ŠPOLJAR-TRANSPORT Ltd.	145.627.605	1.37%
9.	TTI Ltd.	140.312.729	1.32%
10.	METALIJA TRANS Ltd.	137.123.803	1.29%

*Source: drawn up by the author based on the data from Bisnode Croatia (2018) Bisnode Fast Report 2018 for Ricardo Ltd.*

The first factor of concentration is the total number of all companies, and the other one is the factor of distribution of companies' sizes in the targeted industry. The advantage of these ratios is that they are easily calculated (Tipurić, Kolaković and Dumičić, 2003). In order to calculate the concentration ratio in the road freight transport industry in the Republic of Croatia, first, the companies were ranked from higher to lower, based on their turnover in 2017. Table 3 shows the ten leading road transport companies in Croatia and their turnover generated in 2014. It can be seen that the share of the leading company equals barely 2.48%, which leads to the conclusion that Croatian road freight transport industry is fragmented. The share of first ten companies in total industry's turnover in 2017 was just 17.03%. Considering the fact that there are different approaches to what number of companies should be taken into account when calculating the concentration ratio, the indicator of 4 and 8 largest companies in road transport industry was calculated. In case of a monopoly, the value equals 100%, and, in case of a perfect competitiveness, it equals 0%. The share of the first 4 companies was just 8.5%, while the share of the first 8 companies was 14.42%. That is in line with the claim of Žibert and Čorak (2012), who pointed out fragmentation as one of the key issues in Croatian road industry. Taking into consideration that the share of four largest companies equals only 8.5%, it can be concluded that Croatian road freight transport industry is highly fragmented and that there is no company which could significantly influence the industry's profitability.

#### **4. CONCLUSION**

Bearing in mind that road freight transport represents a more significant part of road transport, this research focused on this segment alone. The purpose of this paper was to underline basic characteristics of Croatian road freight industry, the leading industry in Croatian land transportation. Croatian road freight transport industry employs around 22.00 people. It is a highly fragmented industry; the market consists of a large number of small companies, where neither one influences the industry's profitability on a larger scale. Most Croatian transporting companies have small vehicle fleets (up to 5 vehicles) with a poor average age structure. This certainly, in some ways, influences the competitiveness of Croatian transporters outside the

Republic of Croatia. It should be noted that in some EU members toll roads are more expensive for older vehicles and most companies tend to make business deals only with those transporters which possess larger vehicle fleets.

Considering the high fragmentation of the industry and the significant domination of small companies, it is necessary to encourage alliances between them, through clusters or associations, in order to operate together internationally and domestically. That is the only way to take advantage of the unlimited access to the road transport market in the EU. Despite the fact that in Croatia, a few clusters have been operating for years now, their role is still marginal. Most Croatian road transporters are still not aware how alliances would influence their operations and make business dealings easier and more successful, both on the domestic and international market.

#### LITERATURE:

1. Banelli, M., Kolak, A., Vukadinović, D. (2009). *Priručnik za međunarodni cestovni promet*, Zagreb: Banelli d.o.o..
2. Bisnode Croatia (2018). Bisnode Fast Report 2018 for Ricardo Ltd.
3. Botrić, V., Šišinački, J., Škuflić, L. (2006). Road Infrastructure and Regional Development: Some Evidence from Croatia. In Panayotis, Pantazis (Eds). *Proceedings from the 46th Congress of the European Regional Science Association "Enlargement, Southern Europe and the Mediterranean*, Volos: University of Thessaly, pp. 129-130.
4. Boylaud, O., Nicoletti, G. (2001). Regulatory reform in road freight, *OECD Economic studies*, 1(32), pp. 229-251. Retrieved 18.09.2018 from <https://www.oecd.org/eco/outlook/2732085.pdf>.
5. Croatian Bureau of statistics (2013). *Statistical Yearbook of the Republic of Croatia 2013*, Zagreb: Croatian Bureau of statistics.
6. Croatian Bureau of statistics (2017). *Statistical Yearbook of the Republic of Croatia 2017*, Zagreb: Croatian Bureau of statistics.
7. Demir, E., Bektaş, T., Laporte, G. (2014). A review of recent research on green road freight transportation. *European Journal of Operational Research*, 237(3), pp. 775-793.
8. European Commission (2014). Report from the Commission to the European Parliament and the council. Retrieved 20.10.2018. from [https://eur-lex.europa.eu/legal-content/EN/TXT/PDF/?uri=CELEX:52014DC0222&from=en\\_ska](https://eur-lex.europa.eu/legal-content/EN/TXT/PDF/?uri=CELEX:52014DC0222&from=en_ska).
9. European Commission (2018). *EU transport figures. Statistical pocketbook 2018*, Luxembourg: Publications Office of the European Union.
10. European Commission data (2018). Road freight transport by age of vehicle, EU 28, 2013-2017. Retrieved 22.10.2018. from [https://ec.europa.eu/eurostat/statistics-explained/images/5/53/Road\\_freight\\_transport\\_by\\_age\\_of\\_vehicle%2C\\_EU-28%2C\\_2013-2017\\_%28million\\_tonne-kilometres%29.png](https://ec.europa.eu/eurostat/statistics-explained/images/5/53/Road_freight_transport_by_age_of_vehicle%2C_EU-28%2C_2013-2017_%28million_tonne-kilometres%29.png).
11. European Commission DG for Mobility and Transport (2011). Road freight transport vademecum 2010 Report. Market trends and structure of the road haulage sector in the EU in 2010. Retrieved 12.10.2018. from <http://ec.europa.eu/transport/modes/road/doc/2010-road-freight-vademecum.pdf>.
12. Evangelista, P., Sweeney, E. (2014). Information and communication technology adoption in the Italian road freight haulage industry, *International journal of logistics systems and management*, 19(3), pp. 261-282.
13. Ivanova, E., Masarova, J. (2013), Importance of road infrastructure in the economic development and competitiveness, *Economics and management*, 18(2), pp. 263-274. DOI: 10.5755/j01.em.18.2.4253.



14. Laslavić, Ž. (20.09.2008). Samo će udruženi prijevoznici opstati na europskom tržištu. U godinu dana osnovano pet prijevozničkih klastera, *Lider*. Retrieved 09.11.2018. from <http://liderpress.hr/arhiva/54843/>.
15. Lazauskas, J., Bureika, G., Valiūnas, V., Pečeliūnas, R., Matijošius, J., Nagurnas, S. (2012). The research on competitiveness of road transport enterprises: Lithuanian case, *Transport and Telecommunication*, 13(2), pp. 138-147.
16. Litschke, A., Knitschky, G. (2012). Future development in road freight transport regarding more environmentally friendly vehicle technologies, *Procedia-Social and Behavioral Sciences* 48, pp. 1557-1567.
17. Marchington, M., Carroll, M., Boxall, P. (2003). Labour scarcity and the survival of small firms: a resource-based view of the road haulage industry, *Human Resource Management Journal*, 13(4), pp. 5-22.
18. Matos, F. J., Silva, F. J. (2011). The rebound effect on road freight transport: Empirical evidence from Portugal. *Energy Policy*, 39(5), pp. 2833-2841.
19. McKinnon, A. C., Piecyk, M. I. (2009). Measurement of CO2 emissions from road freight transport: A review of UK experience. *Energy policy*, 37(10), pp. 3733-3742.
20. Naletina, D. (2016). *Resursni pristup izvorima konkurentne prednosti u hrvatskoj industriji cestovnoga prijevoza* (doctoral dissertation). Zagreb: Ekonomski fakultet.
21. Ncube, P., Roberts, S., Vilakazi, T. (2015). Study of competition in the road freight sector in the SADC region-case study of fertilizer transport and trading in Zambia, Tanzania and Malawi. *Centre for Competition, Regulation and Economic Development Working Paper*, No. 3. Retrieved 04.11.2018. from [http://static1.squarespace.com/static/52246331e4b0a46e5f1b8ce5/t/55646452e4b0658666cf1c25/1432642642000/CCRED+Working+Paper+3\\_2015+Road+Freight+Sector+Ncube+Roberts+Vilakazi.pdf](http://static1.squarespace.com/static/52246331e4b0a46e5f1b8ce5/t/55646452e4b0658666cf1c25/1432642642000/CCRED+Working+Paper+3_2015+Road+Freight+Sector+Ncube+Roberts+Vilakazi.pdf).
22. Porter, M. (2003). The economic performance of regions, *Regional studies*, 37(6-7), pp. 545-546.
23. Porter, M. (2009). Clusters and economic policy: aligning public policy with the new economics of competition. *ISC White paper*, Retrieved 16.11.2018. from [http://www.hbs.edu/faculty/Publication%20Files/Clusters\\_and\\_Economic\\_Policy\\_White\\_Paper\\_8e844243-aa23-449d-a7c1-5ef76c74236f.pdf](http://www.hbs.edu/faculty/Publication%20Files/Clusters_and_Economic_Policy_White_Paper_8e844243-aa23-449d-a7c1-5ef76c74236f.pdf).
24. Radionov Radenković, N. (2006). Tržište usluga prijevoza robe cestom u Hrvatskoj: vode li ceste u EU?. *Zbornik Pravnog fakulteta u Zagrebu*, Vol. 56(special issue), pp. 567-590.
25. Rajsman, M., Rođak, A. (2015). Znacenje tahografa u radu inspekcije cestovnog prometa i prevenciji prometnih nesreca. *Sigurnost*, 57(1), pp. 41-47.
26. Šolman, S. (2010). The role of road transport in Croatian tourism, *Acta Turistica Nova*, 4(2), pp. 231-245.
27. Streimikiene, D., Baležentis, T., Baležentiene, L. (2013). Comparative assessment of road transport technologies, *Renewable and road transport technologies*, Vol. 20, pp. 611-618.
28. Tipurić, D., Kolaković, M., Dumičić, K. (2003). Koncentracijske promjene hrvatske bankarske industrije u desetogodišnjem razdoblju (1993.-2002.), *Zbornik Ekonomskog fakulteta u Zagrebu*, 1(1), pp. 1-22.
29. Tipurić, D., Pejić Bach, M., Pavić, T. (2008). Concentration of the insurance industry in selected transition countries of Central and Eastern Europe, 1998-2006, *Post-communist economies*, 20(1), pp. 97-118.
30. Vukadinović, D., Tomasović, K., Kolak, A. (2014). Svojstva međunarodnog tržišta cestovnog teretnog prijevoza, *Suvremeni promet*, 34(1-2), pp. 62-69.
31. Žibret, B., Čorak, T. (2012). Održivi razvoj hrvatske transportne industrije. Retrieved 14.10.2016. from <http://www.atkearney.si/images/slovenia/pdf/issue%20paper%20final.pdf>.

# THE ANALYSIS OF COMPANIES OF THE FUEL SECTOR BASED ON THE EXAMPLE OF COMPANIES QUOTED ON THE WARSAW STOCK EXCHANGE IN POLAND AND THEIR FAIR VALUE BETWEEN 2008-2018

**Rafal Parvi**

*WSB University in Wroclaw, Faculty of Economics in Opole  
Wroclaw, Poland  
rafalp4@o2.pl*

## **ABSTRACT**

*This paper examines share price of the companies listed on the WIG-FUEL and their fair value between 2008-2018. Data from 2008 to 2018 were collected from the Stooq.pl (Polish portal of shares). Two hypotheses are tested: (1) value of the shares based on the market price; (2) value of the shares as the fair value of shares. The fuel market was analysed and characterised, also the companies participating in it were described. Nevertheless, the market value of shares does not reflect the fair value of the shares which is currently assigned to different companies in the sector. The research analysed the key financial ratios, the actual value of shares; also the fair value of the fuel sector companies listed on the Warsaw Stock Exchange was calculated.*

**Keywords:** *fuel sector, financial condition, profitability, fuel prices, net profit*

## **1. INTRODUCTION**

The fuel market in Poland is developing and operating very well, and fuel concerns such as PKN ORLEN even extend beyond the borders of the country. It should be noted that along with the sale of fuel, the fuel concerns earn much money, and even after the depreciation, they earn more than average and have a very high rate of return. The Polish fuel market is consolidating and according to it, the share of five grand fuel concerns, including PKN Orlen and Lotos and three foreign ones, is growing. The number of single petrol stations is decreasing, cheap stations located at supermarkets are disappearing. The beginning of 2014 brought surprisingly good results of retail segments of large Polish fuel companies. Evaluation of shares allows to some extent for determining the company's value as a share value does not depend exclusively on demand and supply on the market, but also on many factors which shape its rate starting from valuation of an enterprise by means of different methods up to showing the mechanisms changing the share value in a way increasing its value or underrating it. Therefore, valuation of shares and estimation of their fair value is extremely important. This must be done in an objective manner. Repeatedly, the value of shares listed on WIG20 of the Stock Exchange is distorted and underrated, which is connected with an incorrect valuation of an enterprise's value listed on the Warsaw Stock Exchange. The research concerns the determination of fair value of shares listed on the index of WIG20 when analyzing simultaneously chosen rates of particular companies from WIG20. The value of enterprises listed on this index was checked for proper determination of their fair value as currently their values appears to be underrated.

## **2. FUEL MARKET IN POLAND**

Share price of the companies listed on the Stock Exchange should reflect also their fair value. The fair value can be defined in several ways. In view of the foregoing, the fair value is a value used repeatedly in accounting, and thus in Article 28 (6) of the Accounting Act of 29.09.1994 as "the amount for which a given asset component could be exchanged, and the liability could be paid on market transaction terms between interested and well-informed, unrelated parties. In view of whether the price of shares that are quoted on the stock exchange corresponds to their fair value, should be found in the value alone, since, after all, the values may be diverse, like

the value of a similar company, producing similar goods and operating in the same industry, will also be diverse for various reasons. The subject of trade covers minority shares, and the main market participants are retail investors or minority institutional investors, thus the price of shares should reflect the fair value characterizing the liquid minority interest [Fisher, 2014, pp. 17-18]. The value presented in this way seems righteous, which is confirmed by the premium paid by the investors who announce calls for subscription for shares and plan in this way the purchase of the controlling interest. Then the premium reflects the difference between the level of liquid minority interest and the level of controlling interest. Sometimes the level takes into account benefits resulting from synergy. An investor purchasing the controlling interest in this way receives premiums that appear after taking over control of a company, in the form of funds, business management and making a number of strategic decisions. The fair value of the share price should be determined in accordance with the idea of capital market, namely the market participants should have equal access to data, information and all messages concerning a given company [Jabłoński, Nawrocki, 2011, pp. 45-48]. However, the investors are divided into three groups:

- a) People with access to the most closely guarded information that affects the price and the business value, namely those can the company's management board or shareholders,
- b) Institutional investors with blocks of shares with simultaneous access to the company's management board,
- c) Individual investors who have access to public information.

There is one premise more to determine the fair value of share price. The investors are fond of investing in shares, namely they buy them as in the past they managed to earn on them and they feel that presently the share price is ideal and reflects their fair value and will enable them to obtain fair dividend in the future [Adamska, Fierla, 2012, pp. 89-95]. Such a purchase or sale of shares can largely overestimate or underestimate the share value of a quoted company. Here the chemical industry may serve as an example, namely shares in chemical companies at the beginning of the new millennium, when shares in these companies were being purchased without any analysis in technical terms, but looking at their name and value, which was increasing overnight. In view of the foregoing, this led to excessively high business value above its fair value. The share price should thus reflect the fair value of a company listed on the Warsaw Stock Exchange. For the value of these companies be fair, the market must make available to all investors information regarding companies listed on the Warsaw Stock Exchange. The shareholders should be treated equally; therefore we cannot distinguish majority shareholders as those who should have information unavailable for minority shareholders. First of all, shares should be liquid securities, therefore they should be in free float and have real-time transferability, namely at any moment and at any time during the office hours of the Warsaw Stock Exchange on a business day [Froehlich, 2013, pp. 120-121]. PKN ORLEN and LOTOS are one of the largest fuel concerns in Poland. They are quoted on the Warsaw Stock Exchange, where they are valued in terms of market activity and the potential rate of return from the funds paid by the investors. However, as far as the companies quoted on the Warsaw Stock Exchange in Poland are concerned, it should be noted that they are undervalued because they only follow the WIG-PALIWA index. Moreover, due to the fact that from 2008 their value, in the majority of cases, recovered the maximum value of 2008, thus, especially according to the calculations and conducted studies, it was found that the fair value of the fuel sector companies was impossible to achieve before 2016.

*Figure following on the next page*



Figure 1: WIG-FUEL in the period from 12.2008 to 11.2018 (data of the stooq.pl).

The WIG-PALIWA (WIG-FUEL) index presented in Figure 1 shows that since 2014, the fuel sector companies in Poland have revealed changes and upward trend within their values. It is possible to claim that their value does not reflect the market value and fair value. After 2020, we hope that will be better (data of the stooq.pl). Nevertheless, with such a volatile market and the noticed good moods of investors, it will be possible to achieve the reported maximum and also fair value of the fuel sector companies [Katsenelson, 2013, pp. 34-37].

### 3. FUEL SECTOR COMPANIES QUOTED ON THE WIG-FUEL INDEX IN POLAND

The companies quoted on the WIG-FUEL index are characterised by the good financial condition (gpw.pl, 2018, data of the Warsaw Stock Exchange):

- a) LOTOS - Lotos Group is the largest oil company of the Pomeranian region and the second, in terms of scale, in Poland. It is engaged in the distribution and sale of products and petroleum goods. Grupa Kapitałowa Grupy LOTOS SA (The Capital Group of Grupa LOTOS SA) is a vertically integrated oil company engaged in the extraction and processing of crude oil and the distribution of petroleum products. The company is, inter alia, a leader in the lubricating oils sector. The companies in the Capital Group provide the market with the products, such as unleaded petrol, diesel oils, heating oils, aviation fuel, motor and industrial oils, asphalts and gas. The capital group consists of about twenty direct subsidiaries and ten indirect subsidiaries, including: Lotos Czechowice, Lotos Jasło and extractive: Petrobaltic and Lotos Norge.
- b) MOL - MOL is a leading integrated company of the oil and gas sector in Central Europe, and also the largest company, in terms of sales revenue), in Hungary. The concern is engaged in exploration and extraction of oil and gas (including the deposits in Russia and Kazakhstan), oil refining and the wholesale and retail sale of refinery products. It controls Slovak Slovnaft and the Italian IES refinery. It has shares in the Croatian INA oil company.
- c) PGNiG - PGNiG is the largest company operating in the natural gas market in Poland. The basic activity of this company involved the exploration and exploitation of natural gas and crude oil deposits as well as the import, storage, trade and distribution of gas and liquid fuel. The group consists of companies engaged in exploration and extraction, industry and distribution of gas.

- d) PKN ORLEN - PKN Orlen Group is a dominant producer and distributor of the petroleum and petrochemical products in Poland. It deals with the processing of crude oil into products such as unleaded petrol, diesel, heating oil, aviation fuel, plastics and petrochemical products. Refineries belonging to the PKN Orlen group (in Płock, Trzebnia, Jedlicz) have approx. 70% of the nominal capacity of the Polish refineries. PKN Orlen sells, in terms of the wholesale, about 60% of motor fuel in Poland, the retail sale reaches almost 40%. In Central Europe, the company has the largest chain of the petrol stations located in Poland, Germany, Czech Republic and Lithuania. The PKN Orlen group comprises over eighty companies,
- e) Serinus - SerinusEnergy Inc. is an international company operating in the sector of exploration and extraction of oil and gas. It has a diversified portfolio of assets, including both projects at the stage of exploration and development of deposits, and also projects of the substantial exploration potential. The land concession areas in Brunei as well as shares in a huge land exploration block in Syria are the main assets of the company. In June 2013, the takeover of WinstarEnergy as well as changing the name and KOV logo to SerinusEnergy took place.
- f) Is an independent importer of liquid and gas fuels, which in its offer has: diesel oil, LPG, natural gas, biofuels and electricity. The company's multienergetic offer includes both wholesale sales of fuels for business customers as well as retail sales of propane-butane gas, natural gas and electricity.

#### 4. ANALYSIS AND VALUATION OF THE FUEL SECTOR COMPANIES QUOTED ON THE WARSAW STOCK EXCHANGE (WSE) IN POLAND

Within the fuel sector, one company, which reported its maximum value on 24.09.2014, can be distinguished, and this is PGNIG. The remaining companies did not have its maximum or even fair value, though they can show the net profit and good financial condition. On the other hand, some companies were overvalued by more than 50%. These companies are LOTOS, PKNORLEN. Only MOL is trying to stay ahead and regain its value from the last years (Table 1).

*Table 1: The fuel sector's companies quoted on the Warsaw Stock Exchange in Poland as of 30.11.2018 (own development based on the data of the Warsaw Stock Exchange)*

Name	Average rating	rating	Current price PLN	Maximum price PLN from the beginning of the stock exchange quotation
LOTOS	4.5/5.0	B	82.02	82.02
MOL	4.5/5.0	B	41.18	43.00
PGNIG	3.0/5.0	A	6.45	6.70
PKNORLEN	4.0/5.0	B	110.10	122.00
SERINUS	3.0/5.0	D	0.65	18.90
UNIMOT	4.0/5.0	A	8,84	75.00

Table 2 presents the key ratios that show the financial condition of the fuel sector companies. Within the seven examined companies, the generated profit per share was reported in 5 companies. It shows that the fuel companies prosper properly on the financial market and are able to record higher or lower profits [Parvi, 2016, pp. 64-67; Zaremba, 2014, pp. 89-92]. The price to the operating earnings ratio shows losses of the company and this state of affairs was reported in four stock exchange quoted companies – LOTOS, MOL, PGNiG and PKNORLEN, but SERINUS and UNIMOT generated loss.

*Table 2: Technical Evaluation of the fuel sector's companies quoted on the Warsaw Stock Exchange in Poland as of 30.11.2018 (own development based on the financial data of the companies quoted on the Warsaw Stock Exchange in Poland)*

<b>Name</b>	<b>P/OE (price/ operating earnings)</b>	<b>P/BV (price/ book value)</b>	<b>P/P (price/ profit)</b>	<b>Profit per share</b>
LOTOS	5.17	1.27	0.52	3.416
MOL	8.17	1.18	0.59	109.778 (HUF)
PGNIG	8.38	1.04	0.94	0.096
PKNORLEN	5.84	1.33	0.45	4.823
SERINUS	-4.80	2.46	5.28	-0.003
UNIMOT	-30.31	0,40	0.02	1.192

In contrast, analysing P/BV and P/P, it should be noted that both the price to the book value and the price to profit demonstrate that two companies exemplary operate on the market and have a value more than 1.0 [Parvi, 2016, pp. 39-44], and these are LOTOS, MOL, PGNIG and PKNORLEN. Other companies do not significantly differ from the average values, and these are SERINUS and UNIMOT.

*Table 3: Technical evaluation of the fuel sector's companies quoted on the Warsaw Stock Exchange in Poland as of 30.11.2018 (own development based on the financial data of the companies quoted on the Warsaw Stock Exchange in Poland)*

<b>Name</b>	<b>Net profit (net loss) in thousands PLN</b>	<b>Depreciation in thousands PLN</b>	<b>EBITDA in thousands PLN</b>	<b>Assets in thousands PLN</b>
LOTOS	631600	174700	1041500	22777800
MOL	89955000 (HUF)	92378000 (HUF)	213782000 (HUF)	2147483647 (HUF)
PGNIG	554000	643000	1469000	35986000
PKNORLEN	2063000	677000	2968000	67456000
SERINUS	-570	419	1489	125775
UNIMOT	9770	1421	12333	643773

Table 3 presents the studies concerning, among others, the net profit, depreciation, EBITDA and assets of the fuel sector companies. According to the obtained values, it is clear that only SERINUS showed a loss, which was confirmed by the previous ratios included in Table 3. Other companies have shown a substantial profit which was generated in 2018. The book value per share presents that the companies are overvalued, and these are LOTOS, MOL, PGNIG, PKNORLEN, and in the case of one company, such as SERINUS undervalued. However, it is important not to follow this opinion because the values are only the book values, and the calculation of them is purely mathematical and financial. In the case of using the economic attitude and interpretation [Parvi, 2017, pp. 39-43], it would occur that the companies do not have the fair value (Table 4).

*Table 4: The fuel sector's companies quoted on the Warsaw Stock Exchange in Poland as of 30.11.2018 (own development based on the financial data of the companies quoted on the Warsaw Stock Exchange in Poland)*

Name	Book value per share in PLN
LOTOS	64.666
MOL	2347.414 (HUF)
PGNIG	6.228
PKNORLEN	81.448
SERINUS	0,072
UNIMOT	21.272

*Table 5: The fuel sector's companies quoted on the Warsaw Stock Exchange in Poland as of 30.11.2018 (own development based on the financial data of the companies quoted on the Warsaw Stock Exchange in Poland)*

Name	ROE	ROA
LOTOS	17.52	9.00
MOL	16.36	6.79
PGNIG	9.35	6.68
PKNORLEN	19.49	10.19
SERINUS	-115.19	-9.94
UNIMOT	-2.07	-0.58

The profitability of the equity as well as the profitability of assets is shown only by LOTOS, MOL, PGNIG and PKNORLEN, however, SERINUS and UNIMOT do not have it. Therefore, according to the presented study, it is possible to observe that the fuel concerns have the profitability and they are not threatened by any disturbance of the financial liquidity (Table 5). Currently, the value of companies significantly deviates from the maximum value achieved a few years ago. The only one exception is LOTOS, MOL, PKNORLEN and PGNIG, which achieved the maximum value in its history. Other companies have the value less than 50% of the maximum one - Table 6.

*Table 6: The fuel sector's companies quoted on the Warsaw Stock Exchange in Poland as of 30.11.2018 (own development based on the financial data of the companies quoted on the Warsaw Stock Exchange in Poland)*

Name	Current value	Maximum value
LOTOS	82.02	82.02
MOL	41.18	43.00
PGNIG	6.45	6.70
PKNORLEN	110.10	122.00
SERINUS	0.65	18.90
UNIMOT	8,84	75.00

Table 7: The fuel sector's companies quoted on the Warsaw Stock Exchange in Poland as of 30.11.2018 (own development based on the financial data of the companies quoted on the Warsaw Stock Exchange in Poland)

Name	Fair value	Deviation from the fair value in PLN
LOTOS	83.00	0.98
MOL	45.00	3.82
PGNIG	7.00	0.55
PKNORLEN	120.00	9.90
SERINUS	5.00	4.35
UNIMOT	25.00	16.16

However, the fair value which should be reflected by the share prices of the examined companies significantly differs from the calculated value [Froehlich, 2013, pp. 67-75], which was presented in Table 7. In some cases, it is even 50% of the current value. However, the fair value is considerable higher than the current value of the examined companies, and only similar in four company, LOTOS, MOL, PGNIG and PKNORLEN.

Deviation from the fair value in PLN = DevFV  
 DevFV = Fair value - current value (table 7).

## 5. CONCLUSION

The share price of the fuel sector companies quoted on the Warsaw Stock Exchange in Poland is significantly underestimated by the current financial situation in the world [Jabłoński, 2011, pp. 32-55]. Nevertheless, fuel companies should demonstrate the higher value and at least the fair value because fuel prices are stabilized, and their profits indicate good financial condition, especially within grand fuel concerns, such as PKN ORLEN, LOTOS and PGNIG. The value of the fuel sector companies should be valued because the companies have the majority of assets expressed in the fuel supplies. Fuel companies earn money because they largely focus on the fuel sale as well as the increase or decrease of the sale price. Therefore, the constantly kept stores result in the profit growth and sometimes the decrease of profit together with the price which is liquid and reflects their current assets. However, they achieve huge profits which was confirmed in the studies of ratios in the last few years and the net profit studies in 2018. The fair value of the fuel sector companies quoted on the Warsaw Stock Exchange in Poland should be achieved within three years, until 2020, with the improvement of situation on the Global financial markets.

## LITERATURE:

1. Adamska, A., Fierla, A., (2012). *Inwestowanie. Kolekcjonowanie, Spekulowanie*. Warszawa. SGH.
2. Fisher, P., (2014). *Zwykłe akcje, niezwykle zyski oraz inne dzieła*. Polska. MT Biznes.
3. Froehlich, B., (2013). *Strategie inwestycyjne na każdą pogodę*. Polska. Wolters Kluwer.
4. Jabłoński, B., Nawrocki, T., (2011). *Inwestowanie na rynku akcji. Jak ocenić potencjał rozwojowy spółek notowanych na GPW w Warszawie*. Warszawa. CeDeWu.
5. Katsenelson, V., (2013). *Jak zarabiać na rynku, który zmierza donikąd. Aktywne inwestowanie w wartość*. Polska. Linia.
6. Parvi, R., (2016). "Analysis of the energy sector in Poland on the example of energy industry companies quoted on the stock exchange". Slovakia. Itall Ltd. pp. 64-67
7. Parvi, R., (2016). "Fair value of the banking sector companies quoted on the Warsaw Stock Exchange in Poland within 2006-2016 and their financial analysis". Czech Republic. Thomson Ltd. pp. 39-44.



8. Parvi R., (2017). „Share price of the companies listed on the WIG-UKRAINE and their fair value”. London, pp. 39-43.
9. Zaremba, A., (2014). *Gięda. Podstawy inwestowania*. Warszawa. Helion.
10. gpw.pl (2018) - portal giełdowy
11. stooq.pl (2018) - portal giełdowy

## CONSUMER POLICY AND ITS TOOLS IN CONDITIONS OF THE SLOVAK REPUBLIC

**Daniel Halaj**

*Faculty of Forestry, Technical University in Zvolen, Slovakia  
daniel.halaj@tuzvo.sk*

**Zuzana Dobsinska**

*Faculty of Forestry, Technical University in Zvolen, Slovakia  
dobsinka@tuzvo.sk*

### **ABSTRACT**

*This paper deals with the analysis of the consumer policy in the Slovak Republic and its efficiency from the consumers' point of view. The opinions on the consumer policy were investigated by the qualitative marketing research methods with the using of structured questionnaire on the sample  $n = 625$  respondents. The research results were evaluated by the one and two-dimensional statistical methods. The paper offers the assessment of the consumers' opinions on the companies selling goods and services, on the state consumer protection and on the satisfaction with the quality of the goods and services on the market. One of the results is also the consumers' experience with the purchasing and sales returns, and with the consumer organizations. The research findings refer about the positive and negative consumers' experiences and proposals for the enhancement of the consumer policy in the Slovak Republic.*  
**Keywords:** *consumer, marketing, policy*

### **1. INTRODUCTION**

Despite of the fact that the professionals has been dealing with this topic for decades in the previous century (Andreasen, Manning, 1980; Kristensen, 1980; Wiskström, 1983; Andreasen, 1977; Micklitz, Weatherill 1993), consumer policy rises more and more on its own interest for this millennium. The consumers are often uninformed about their rights and the ways of the protection and solution of their individual arguments. For this reason, the consumer policy meets an extraordinary role in the consumer protection. The awareness about the consumer policy is very important not only at the company level as a part of the socially responsible marketing, however, at the level of individual consumers. At the global level, there are many examples of high-class studies or research investigation focused on consumer policy, for instance on customers behavior (Strünck, 2015; Mandel et al., 2017; Wei, Zhang, 2018), consumer complaints (Dailey, Ülkü, 2018) or consumer policy and consumer law (Micklitz et al., 2011). Consumer policy defines economic, legislative, social, commercial and other measures which are performing in support of consumer. Consumer presents personality and citizen in the role of customer, buyer and consumer on the market, and on the other hand, producer or creator of the social values (Ramsay, 2012). From the major part, the consumer policy in conditions of the Slovak Republic does not promise a trust (Zelienkova, 1996). The meaning of the consumer policy lies on consumer protection against unfair trade practices of the producers or distributors. To come across the market, producers use a lot of production technology and raw materials inputs which can endanger the consumers' health (OECD, 2010). Ministry of Economy of the Slovak Republic adopted a decision and elaborated the Strategy of the consumer policy of the Slovak Republic for the period 2014-2020. This strategy concerns also the proposal of the European parliament and of the Council on a consumer program 2014 - 2020. This regulation supports the goals of renewed consumer protection EU policy. The protection policy places the consumer into the center of the unique market. The consumers are determining for providing the intelligent, inclusive, and sustainable economic growth in the

EU. The regulation has for its goal to ensure high degree of protection for all consumers, whereby the attention is focused on vulnerable consumers with the goal of strengthen their abilities and make provision for their individual needs. Regarding this fact, the Ministry of Economy of the Slovak Republic decided to elaborate integrated enactment, called "Consumer codex" or "Consumer code of laws" which contains complex legal regulations in area of consumer protection (MH SR, 2014). At the national level, there is a lack of studies or research investigation about the consumer policy. Mostly they focused on identification of factors influencing the consumer policy or consumer protection (Čimo, 2014; Lipianska, et al. 2014). From the reason of the prevailing supply over the demand on consumer products with the different quality, as well as diverse marketing practices by producers and their distributors, it is highly necessary to deal with this topic further (Reinartz et al. 2011; Raff, Schmitt, 2016; Meinen, Raff, 2018). Therefore, the main goal of this research is the analysis of the consumer policy and its efficiency from the consumer point of view in the Slovak Republic.

## 2. METODOLOGY

The methods of qualitative statistical analysis were used for investigating the opinions of the chosen respondents on the consumer policy (Wackerly et al., 2001). The structured questionnaire with closed questions and measure scales was used as a tool of the qualitative approach (Silverman, 1996). The questionnaire was first tested by so called pre-test on the sample of 15 respondents to avoid the intelligibility of selected questions. After some corrections related to the pre-test, the questionnaire was adjusted to electronic version via google docs. The respondents were obtained by random sampling. The frequency of respondents' opinions on individual questions was first analyzed by one-dimensional statistical method. Subsequently, determined null hypothesis were tested using two-dimensional statistical methods:

- Hypothesis 1: The knowledge level of the basic terms for the consumer policy is not influenced by the level of respondents' education
- Hypothesis 2: The consumers' experience with the sales returns does not influence their evaluation of the consumers' position against producers
- Hypothesis 3: The respondents' ability to define unfair business practices is not dependent on their age or the educational level
- Hypothesis 4: Decision-making about using the consulting of consumer association is not influenced by the income level of consumers

The size of the respondents' sample was calculated following the formula:

$$n \geq \frac{(z^2 \times p \times q)}{\Delta^2}$$

where:

n – minimum number of respondents, z - reliability coefficient by the value 2 (1.96) at the probability of the 95.4 %, p and q - the percentages of respondents knowing and unknowing the topic which was set up on 50 % x 50 % what represents the highest rate of entropy, and  $\Delta$  – the maximum admissible error set up on the 4 %. The size of selected sample by following the chosen values represents:

$$n \geq \frac{(2^2 \times 0.5 \times 0.5)}{0.04^2} \geq 625 \text{ respondents}$$

Cramer contingency coefficient (V) was used for testing the hypothesis which is the most suitable rate for the association between the two categorical variables and it reaches the values from 0 – non-relation to 1 – ideal relation (Rimarčík, 2007):

$$V = \sqrt{\frac{x^2/n}{\min(R, C) - 1}}; \text{whereby } x^2 = \sum_{i=1}^R \sum_{j=1}^C \frac{(n_{ij} - E_{ij})^2}{E_{ij}} \text{ and } E_{ij} = \frac{n_i n_j}{n}$$

where:

n – file size, R – number of rows (categories of row variable), C – number of columns (categories of column variable),  $n_{ij}$  – frequency in  $i$ -row and  $j$ -column,  $E_{ij}$  – expected frequency in  $i$ -row and  $j$ -column,  $n_i$  – sum of the frequencies in  $i$ -row,  $n_j$  – sum of the frequencies in  $j$ -column

The scale by Cohen (1988) was used for the interpretation of the contingency coefficient or correlation coefficient (Rimarčík, 2007): < 0.1 trivial, 0.1 – 0.29 small, 0.3 – 0.49 middle, 0.5 – 0.69 strong, 0.7 – 0.89 very strong and > 0.9 is almost ideal dependency

The confidential interval (CI) was calculated by chosen questions for the share of the qualitative character on the main file of characters for the binomial distribution following the formula (Šmelko, 1995):

$$95\% \text{ CI} = w \pm 1.96 \sqrt{\frac{w(1-w)}{n}}$$

where:

w – value of the qualitative character, 1.96 – reliability coefficient for the probability of 95.4 %, n – file size.

### 3. RESULTS AND DISCUSSION

#### 3.1. One-dimensional statistical results

Totally, 44% women and 56% men took part at this research. Selected respondents represented all proposed age categories almost at the equal level. Concerning the education level of respondents, the survey represents also all education levels at the nearly uniform rate. However, distribution of the category with disposable income was different at the individual scales. The most respondents (28%) earned less than 300€, what was caused due to high rate of student respondents in amount of 44%. On the other side, the second highest group of respondents were employed people with 40%. Nevertheless, at the level of the current average salary in the Slovak Republic (approximately a thousand Euro per month) belonged only 12% of respondents. By reason of high amount of research data, they were selected by following outputs to discuss. Figure 1 reveals the respondents' knowledge about the consumer policy. It is evident, that the term "consumer protection" was recognized by Slovak respondents in amount of 83%. However, the term "consumer policy" was known to only 37 %, what is regarding on efforts of the EU and consumer associations very low number. Concerning the respondents' education, the highest rate of knowledge by this term had the university students. However, more than half of all these respondents did know this term (Fig. 1).

*Figure following on the next page*

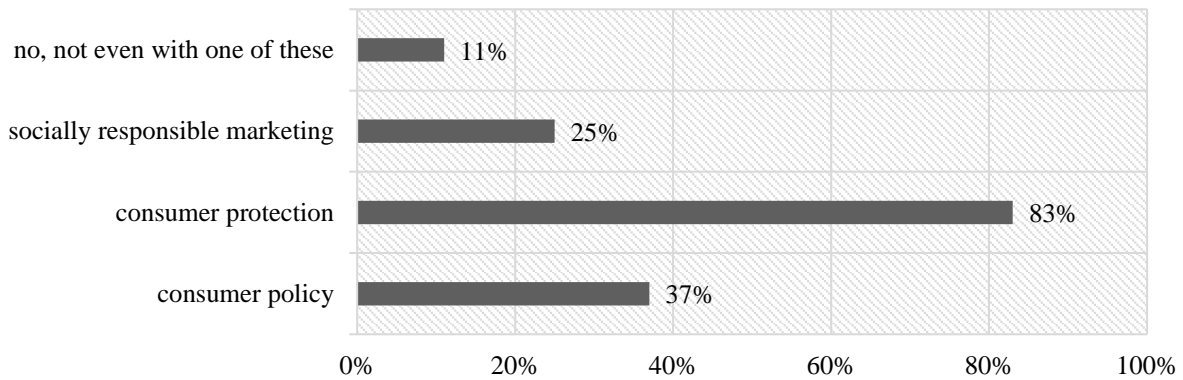

Figure 1: Consumer knowledge about selected terms

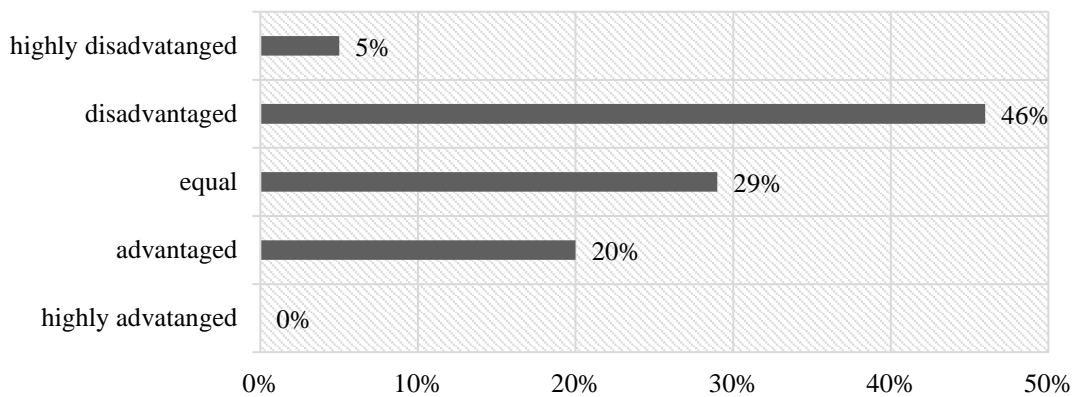

Figure 2: Consumer position on the market against producers of goods and services

There is a certain relation between consumers' dissatisfaction with the state activities with 60% of unsatisfied respondents (Fig.3) and with the opinion of the consumer position on the market as disadvantaged by 46% (Fig. 2). Coming from this, the state should improve and more enforce the activities leading to the consumer protection. Thereby, the position of the consumers on the market could raise what is also one of the areas of the strategy of consumer EU policy. The results of consumer experiences with the selected unfair business practices refers to very disquieting findings (Fig. 4). Respondents at rate of 90 % pointed that they have met with unfair business practices as are false prices, advertising or packaging. More than 60% have faced with high pressure selling, and more than 70% were confronted with purchase of poor-quality products, dangerous to health.

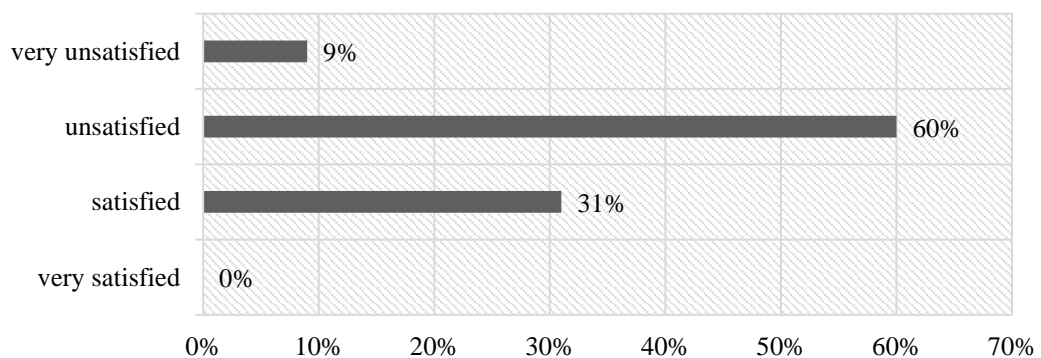

Figure 3: Assessment of the state activity for ensuring and enhancement of consumer protection

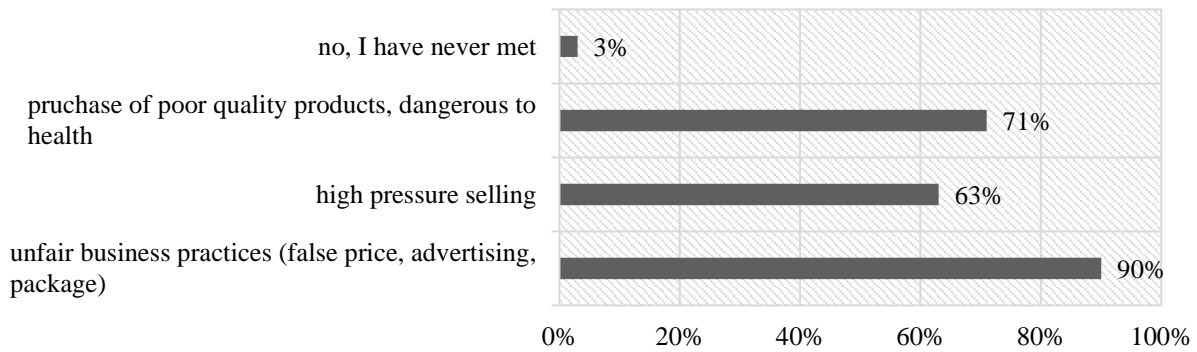

Figure 4: Consumer experiences with selected unfair business practices

Further findings point out that almost all respondents (95%) used their rights to return their purchased products. This implies that the consumers are conscious of some their rights, they are not turn away to them and they try for their achievement. Following the calculation of the confidential interval (CI) with the 95% probability we can expect that from 94% to 100% of respondents will claim their purchased goods. To 81% of asked consumers had positive experience with the claim and only 43% had a negative one. It must be notice that some of them marked both possibilities. At the level of 95% probability, from 76% to 90% of respondents will have positive experience with the reclaiming of the products. Thirty percent of respondents with bad experience of the claim, was from the reason that their claim was not accepted. Another 10% of the claim was not handled at all. As a reason, why respondents do not claim about their products, 53% of respondents noticed due to low price, 11% for negative experience with the claim, 12% do not trust in claiming process and 10% see behind it a lot of administrative obstructions. The state should involve into the strategy of the consumer policy also the questions of the advertisement, ways how consumer could reach their rights and how to increase the trust in claiming process and exercisability of their rights. For instance, to provide so called mystery shopping with the focus on claims with proper measures. More than 90% of asked respondents did not participate in any program organized by state or consumer organization for consumer education (guidance about the quality, prices, dangerous products, standards, financial literacy etc.). It is obvious, that the government efforts and consumer associations are weak in this area and they should work on the consumer enlightenment. Only 15% of respondents used help and consulting of some consumer association for the solution of their consumer problems. The reasons why respondents never used any help or consulting was several. The most detected answer was that the respondents such a support did not need, or they released they helped themselves or they looked for help on internet.

### 3.2. Two-dimensional statistical results

Testing the first hypothesis by p-value (chi-square statistic)  $0.19690 > 0.05$  we failed to reject the null hypothesis and cannot accept the alternative hypothesis. The p-value was higher than defined significance level. The obtained difference in the sample was not statistically significant. We can state that the knowledge level of the basic terms for the consumer policy is not influenced by the level of respondents' education. The p-value by chi-square test reached 0.85273 for the second hypothesis. The null hypothesis was not rejected, and the alternative hypothesis cannot be accepted. The p-value was higher than defined significance level 0.05. The obtained difference in the sample was not statistically significant. We can state that the consumers' experience with the sales returns does not influence their evaluation of the consumers' position against producers. By testing the third hypothesis we got the p-value of chi-square test  $0.66897 > 0.05$ . Following this result, we can state that the null hypothesis cannot be rejected, and the alternative hypothesis accepted.

The respondents' ability to define unfair business practices is not dependent on their age or the educational level. Testing the fourth hypothesis by chi-square test the p-value reached 0.07133. The p-value was higher than defined significance level 0.05. We failed to reject the null hypothesis and cannot accept the alternative hypothesis. We can state that decision-making about using the consulting of consumer association is not influenced by the income level of consumers.

#### 4. CONSLUSION

Following the results, we have identified negative and positive facts of the current consumer policy (Tab. 1) and, we have proposed some improvements to this very important topic at the European level or for the Slovak Republic.

*Table 1: Summary findings from the realized research*

Negative facts	Current efforts for the consumers enlightenment are ineffective and do not deliver desirable results
	Very low participation on consumers programs focused on education and informing the consumers
	Strengthen the consumer position in the EU is not the goal for the strategy of the consumer policy 2014-2020
Positive facts	To ensure that the goods and services and foodstuff would be healthy, is the main goal of the consumer policy
	Consumer associations are helpful for the consumers they do not help themselves by solutions of their own consumer problems.

Concerning the results, we can propose some improvements for the consumer policy in the Slovak republic:

1. The increasing of the awareness about the consumer policy among the consumers in the Slovak Republic.
2. Repeatedly include into the strategy of consumer policy, the strengthen of the consumer position. If not within the whole EU, so definitely within the Slovak Republic.
3. Increasing the control not only the producers regarding the product quality and security but also the distributors, sellers with the specialization on detection of using unfair business practices or pressure selling.
4. To ensure the reachability of consumers rights in case of products claims and disputes with the sellers or producers.
5. The consumer associations should maintenance or enhance the level of their services for consumers.
6. The entrepreneurs' awareness in area of socially responsible entrepreneurship.

**ACKNOWLEDGEMENT:** *This research was financially supported by the two projects of the Slovak Research and Development Agency (APVV-15-0715) and (APVV-17-0232).*

#### LITERATURE:

1. Andreasen, A. R. (1977). Consumer dissatisfaction as a measure of market performance. *Zeitschrift für Verbraucherpolitik*, Volume 1, Issue 4, pp 311–322
2. Andreasen, A. R., Manning, J. (1980). Information needs for consumer protection planning. *Zeitschrift für Verbraucherpolitik*. Volume 4, Issue 2, pp 115–126
3. Cohen, J. (1988). *Statistical Power Analysis for the Behavioral Sciences*, Second Edition. Lawrence Erlbaum Associates, Publishers, ISBN 0-8058-0283-5

4. Čimo, J. (2014). The impact of innovation on consumer policy Slovak Republic. *Vzdelaný spotrebiteľ a spotrebiteľská politika SR*, Bratislava, Zborník vedeckých statí, [in Slovak] p. 33-41, ISBN 978-80-225-3964-7
5. Dailey, L C., Ülkü, M. A. (2018). Retailers beware: On denied product returns and consumer behavior. *Journal of Business Research*, Volume 86, Pages 202-209, <https://doi.org/10.1016/j.jbusres.2018.01.064>
6. Drucker, P. (1993). *Managing in Turbulent Times*. New York: Harper & Row.
7. Kristensen, P. S. (1980). What consumers want and what they get from complaints directed at the place of purchase. *Zeitschrift für Verbraucherpolitik*. Volume 4, Issue 1, pp 1–7
8. Lipianska, J., Hlavatý, I., Červenka, P. (2014). Consumer protection and its place in the EU Consumer Policy. *Vzdelaný spotrebiteľ a spotrebiteľská politika SR*, Bratislava, Zborník vedeckých statí, [in Slovak] p. 130-133, ISBN 978-80-225-3964-7
9. Mandel, N., Rucker, D. D., Levav, J., Galinsky, A. D. (2017). The Compensatory Consumer Behavior Model: How self-discrepancies drive consumer behavior. *Journal of Consumer Psychology*, Volume 27, Issue 1, Pages 133-146, <https://doi.org/10.1016/j.jcps.2016.05.003>
10. Meinen, P., Raff, H. (2018). *International trade and retail market performance and structure: Theory and empirical evidence*. *Journal of International Economics*, Volume 115, Pages 99-114, <https://doi.org/10.1016/j.jinteco.2018.08.010>
11. MH SR, (2014). *Návrh Stratégie spotrebiteľskej politiky Slovenskej republiky na roky 2014 – 2020*. [Proposal of the Consumer policy strategy of the Slovak Republic 2014-2020] Retrieved 23.02.2017 from <https://www.mhsr.sk/uploads/files/j7uFbSII.pdf>
12. Micklitz, H.-W., Reisch, L. A., Hagen, K. (2011). An Introduction to the Special Issue on “Behavioural Economics, Consumer Policy, and Consumer Law”. *Journal of Consumer Policy*, Volume 34, Issue 3, pp 271–276
13. Micklitz, H. -W., Weatherill, S. (1993). Consumer policy in the European Community: Before and after Maastricht. *Journal of Consumer Policy*, Volume 16, Issue 3–4, pp 285–321
14. OECD, (2010). *Consumer Policy Toolkit. Summary in Slovak*. ISBN 978-92-64-079656 Retrieved 14.02.2017 from [www.oecd-ilibrary.org/deliver/9789264079663-sum-sk.pdf?itemId=/content/summary/9789264079663-sum-sk&mimeType=application/pdf](http://www.oecd-ilibrary.org/deliver/9789264079663-sum-sk.pdf?itemId=/content/summary/9789264079663-sum-sk&mimeType=application/pdf).
15. Raff, H., Schmitt, N. (2016). *Retailing and international trade*, Handbook on the Economics of Retailing and Distribution, Edwar Elgar Publishers, Cheltenham, pp. 157-179
16. Ramsay, I. (2012). *Consumer Law and Policy*, Third Edition, ISBN-13: 978-1849462624
17. Reinartz, W., Dellaert, B., Krafft, M., Kumar, V. Varadarajan, R. (2011). Retailing Innovations in a Globalizing Retail Market Environment. *Journal of Retailing*, Volume 87, Pages S53-S66, <https://doi.org/10.1016/j.jretai.2011.04.009>
18. Rimarčík, M. (2007). *Štatistika pre prax. [Statistics for praxis]* Vydané nákladom vlastným, 2007. ISBN 978-80-969812-1-1.
19. Strünck, C. (2015). Consumer Policy. *International Encyclopedia of the Social & Behavioral Sciences (Second Edition)*, Pages 733-737, <https://doi.org/10.1016/B978-0-08-097086-8.75057-4>
20. Šmelko, Š. 1995. *Štatistické metódy v lesníctve. [Statistical methods in forestry]* Zvolen: Technická univerzita, 1995. ISBN 8022806846.
21. Wei, M. M., Zhang, F. (2018). Recent research developments of strategic consumer behavior in operations management. *Computers & Operations Research* Volume 93, Pages 166-176, <https://doi.org/10.1016/j.cor.2017.12.005>
22. Wikström, S. (1983). Another look at consumer dissatisfaction as a measure of market performance. *Journal of Consumer Policy*. Volume 6, Issue 1, pp 19–35
23. Zeliénková, Z. (1996). *Spotrebiteľská politika a jej nástroje. [Consumer policy and its tools]* In Transformácia výučby marketingu na Obchodnej fakulte Ekonomickej univerzity v Bratislave: zborník príspevkov zo seminára k 5. výročiu vzniku katedry marketingu. Bratislava: Ekonomická univerzita v Bratislave, ISBN 80-225-0800-4. p 144–149



## THE CONVERGENCE OF AGRICULTURAL GROWTH

**Cezary Klimkowski**

*Institute of Agricultural and Food Economics, National Research Institute, Poland*

*cezary.klimkowski@ierigz.waw.pl*

### **ABSTRACT**

*In the globalized world the convergence of economic growth processes in various sectors world-wide is expected and agriculture is no exception. The authors focused on convergence of development processes in agriculture sectors. The main aim of the paper is to examine whether there is such convergence globally and regionally. Using yearly data from more than 100 countries and years 1992-2016, it was proven that there are strong beta agricultural growth convergence when various technical effectiveness indicators and the share of agricultural employment in total employment are taken into account. However there are strong global divergence of the level of agricultural value added per worker across countries and Europe is the only exception. The results suggests that despite some significant agricultural growth convergence processes there are still substantial differences in agricultural sectors among analyzed countries and the capital equipment is one of the most important one.*

**Keywords:** *Agriculture, agricultural development, agricultural growth, convergence*

### **1. INTRODUCTION**

All economists dealing with broad-spectrum of problems referring to economic growth and development are familiar with topic of growth convergence (Solow 1956; Jones 2008). It is assumed that the problem of economic convergence was popularized by Barro and Sala-i-Martin (1992). Since then many analysis were conducted when different aspects of growth and development convergence was scrutinized. For instance, Siljak (2015) are showing a broad survey of agricultural growth convergence analysis. Convergence topic is very often raised by the economists concerning economic growth (Majchrzak, Smędzik-Ambroży, 2014). Growth convergence in agriculture is very important topic. Development of agricultural sector is of utmost importance since the occurrence of shift from an agrarian to an industrially based economy is strictly dependent on the growth of the productivity in agriculture (Gollin et al, 2002; Olsson, Hibbs, 2005). Agricultural development plays also a fundamental role in reducing poverty (Thirtle et al., 2003). Agricultural development processes are very complex and depend on many different factors (Olujeny, 2006). There is still ongoing debate on what factors are the most important. Moreover, there is no consensus, what agricultural development really means. There are numerous definitions of agricultural development in the literature (Sabouri Solouki, 2015). It is understandable since various objective of this development are determined by economists or policy makers. There are also numerous agricultural development indicators that can be employed. For instance, broad selection of possible indicators were used by Abdollahzadeh et al (2012) to measure the regional differences in agricultural development in Iran. Among 87 various indicators there were ones related to the infrastructure, social issues or structure and effectiveness of production. Although using so many indicators can be very beneficial it also brings some serious difficulties. The most important one refers to the availability and comparability of data. Reliable databases are available only on national level. No such database that let international comparison is available. Other problems refer to complicated issues of weighting the indicators and mixing indicators related to inputs with those related to output of agricultural systems. Still among different agricultural development indicators the most popular are: Gross Value Added per employee, employment in agriculture and various technical production effectiveness measures (Siudek 2007; DeConti et al, 2017).

The author will use mentioned above indicators to answer the question, whether there was convergence processes in last two and a half decade in agricultural sectors worldwide. The main aim of this article is to verify occurrence of beta- and sigma-convergence in agricultural growth processes regionally and globally in this period.

## 2. DATA AND METHODS

Two main sources of data were employed in the analysis. The first source of data is WORLDBANK database, which is available free online (<http://databank.worldbank.org>). From this database information about the employment in agriculture as a share of total employment and the level of value added per worker in agriculture (in constant 2010 \$) were taken. Originally WORLDBANK database offers data for 259 countries and group of countries. However in this analysis only data for 131 countries in case of employment in agriculture and 91 countries in case of value added were used. First data for regions and group of countries were subtracted. Then analysis was limited to countries with population more than 1 million citizens. Data refers to smaller countries very often occurred to be outliers and can significantly disturb observed trends. Countries that were during analyzed period in the state of war were also excluded from database. The second group of data refers to indicators of agricultural production effectiveness. This effectiveness was measured using average level of yields for potato, rice and wheat production for a given country on a yearly basis. All needed information was taken from FAOSTAT database in the production data section available online (<http://www.fao.org/faostat/en/#data/RF>). In this database smaller range of countries is included. Taking mentioned above thresholds and availability of the specific data information from 99 countries for potato yields, 72 countries for rice yields, and 77 countries for wheat yields were employed. Apart from estimating beta- and sigma-convergence globally, countries were grouped in four continental subdivisions. Australia and New Zealand was attached to the Asia group. To verify the occurrence of convergence in the analyzed period two convergence measures were employed. The first one is the beta-convergence measure. It helps to answer the question if the scrutinized variable rises faster in these countries where the initial level of variable were lower, and simultaneously the growth pace of analyzed variable is lower in countries where initially value of the variable was higher. If it occurs we can say that there is beta-convergence and weaker individuals are "chasing" the stronger ones. To estimate beta-convergence simple model is estimated, which can be written as:

$$\ln \left( y_{i,1} / y_{i,1+T} \right) = a + b * \ln(y_{i,1}) + u_t,$$

where:  $y_{i,1}$  – variable for  $i$ -th country in 1<sup>st</sup> period,  
 $T$  – the length of analyzed period,  
 $b$  – coefficient measuring occurrence and the pace of convergence,  
 $u_t$  – random component (Kusideł, 2013, p. 46).

Ordinary least squares regression is used to evaluate  $b$  coefficient. If  $b < 0$  and statistically significant it means that there are beta-convergence and the pace of growth of analyzed variables is higher for those countries where initially value of the variable were lower. If  $b > 0$  and statistically significant there is beta-divergence. Being more precisely 1<sup>st</sup> period is the average level for first three years of analyzed period (1992-1994). The growth of analyzed variable was measured using the ratio of the average level in last three years of analyzed period (2014-2016) to the average level in first three years (1992-1994). Using three-year average helps to avoid problems with short term fluctuation, which is especially important when yields are analyzed. Sigma-convergence means that there was a significant reduction in the dispersion of analyzed variable during analyzed period.

To verify if there was the sigma-convergence variance of analyzed variable in the 1<sup>st</sup> ( $\sigma^2_1$ ) and the last period ( $\sigma^2_2$ ) is compared. The same as in case of beta convergence these periods are three-year average. If  $\sigma^2_1 > \sigma^2_2$  and the difference is statistically significant sigma-convergence is proved. Opposite, if  $\sigma^2_1 < \sigma^2_2$  and it is statistically significant there is sigma-divergence. To verify statistical significance statistics  $T = \sigma^2_1/\sigma^2_2$  for  $\sigma^2_1 > \sigma^2_2$  and  $T = \sigma^2_2/\sigma^2_1$  for  $\sigma^2_1 < \sigma^2_2$  is used. This T-statistics has Fisher–Snedecor distribution with (N-2, N-2) degree of freedom, where N equals the number of countries in the analyzed sample.

### 3. RESULTS

The results of the analysis are presented in three subsections. The scheme of presenting the results is the same in all three parts. First subsection refers to technical effectiveness indicators. Then the convergence of the share of employment in agriculture is presented. The last subsection is related to the changes in the level of value added per worker in agriculture in the analyzed period.

#### 3.1. Production effectiveness indicators

The first analyzed indicator is potato yields. It changes between years 1992-1994 in relation to initial value for three regions and globally is presented in figure 1. Strong negative relation can be seen in all cases. This mean that the lower original level of the potato yields, the stronger growth between 1992 and 2016. It implies that there were evident beta-convergence in the potato yields. The aim of presenting this relation in the graphic form is to help understanding the nature of beta-convergence. The results for next indicators will be presented only in tables.

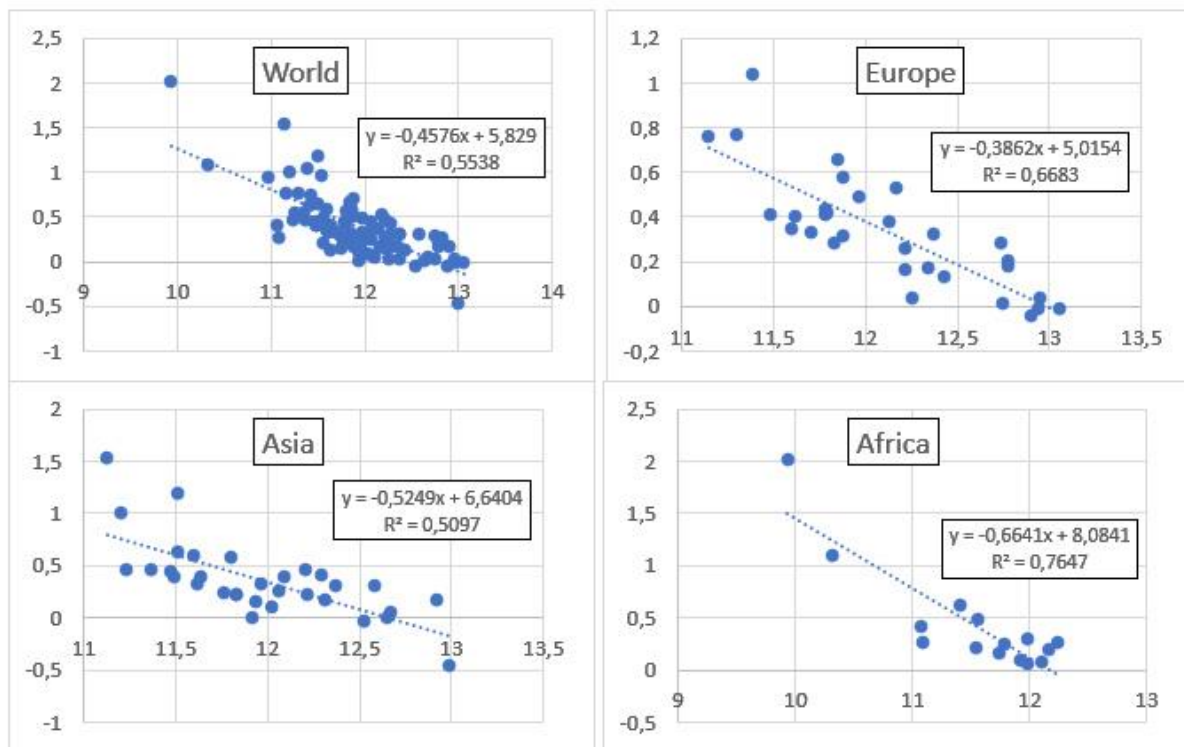

Figure 1: Average potato yields in 1992-1994 (x-axis - kg/ha logarithm) and growth between years 1992-1994 and 2014-2016 (y-axis logarithm) globally and for Europe, Asia, and Africa (own elaboration on the FAOSTAT database)

Table 1 shows the results of analysis for beta- as well as for sigma-convergence. The left part of the table refers to beta-convergence results.

Negative and statistically significant  $\beta$  coefficient indicate that there is beta-convergence. The statistical significance is marked by number of asterisks after every figure. It shows the level of confidence. Three asterisks equals 99% confidence level, two – 95% confidence level, and one asterisk – 90% confidence level. There was strong beta-convergence for every region in analyzed period. On the right side of the table there are presented results of sigma convergence analysis. The value of the variance decreased between 1992 and 2016 for all analyzed regions except Americas. However no conclusions about sigma convergence can be drawn since all changes are insignificant according to F-test critical values.

*Table 1: Potato yields convergence analysis between years 1992-1994 and 2014-2016  
 (own elaboration on the FAOSTAT data basis)*

	$\beta$ -convergence		$\Sigma$ -convergence	
	b coefficient	Decision	$S^2_{(14-16)}/S^2_{(92-94)}$	Decision
World	-0,458***	Convergence	0,894	-
Europe	-0,386***	Convergence	0,761	-
Asia	-0,525***	Convergence	0,828	-
Africa	-0,664***	Convergence	0,832	-
Americas	-0,423***	Convergence	1,118	-

Coexistence of beta-convergence with no sigma-convergence indicate, that although yields rise faster in those countries where its original differences value was lower, the initial differences across countries were too large to observe significant fall in the dispersion of potato yields. If this initial value differences were even bigger,  $\beta$ -convergence can coexist together with sigma-divergence. This is true to some degree for rice yield, as it can be seen in table 2. Although strong beta-convergence was proved, still there was a growth of variance of rice yields during analyzed period globally and for all regions except Europe. However since this growth was not statistically significant, we cannot say that there was sigma-divergence. Results of rice yields convergence analysis is therefore the same as for potato yields. Globally and for every analyzed region we can confirm that yields grow faster in countries with lower initial level.

*Table 2: Rice yields convergence analysis between years 1992-1994 and 2014-2016  
 (own elaboration on the FAOSTAT data basis)*

	$\beta$ -convergence		$\Sigma$ -convergence	
	b coefficient	Decision	$S^2_{(14-16)}/S^2_{(92-94)}$	Decision
World	-0,311***	Convergence	1,132	-
Europe	-0,417**	Convergence	0,691	-
Asia	-0,394***	Convergence	1,031	-
Africa	-0,223*	Convergence	1,387	-
Americas	-0,348***	Convergence	1,353	-

In the case of wheat yields beta-convergence the results are similar to those referring to potato and rice. Global beta-convergence is proved. Only in African countries negative relation between the initial value and growth pace is not statistically significant. The most important difference concerns sigma-convergence results. As it is presented in table 3 one can observe that there is sigma-divergence globally as well as for Asian countries. This indicate that differences in wheat yields across countries were very big – especially for Asia - and even though there are convergence processes going on still the dispersion of wheat yields is growing.

*Table 3: Wheat yields convergence analysis between years 1992-1994 and 2014-2016  
 (own elaboration on the FAOSTAT data basis)*

	β-convergence		Σ-convergence	
	b coefficient	Decision	$S^2_{(14-16)}/S^2_{(92-94)}$	Decision
World	-0,250***	Convergence	1,401*	Divergence
Europe	-0,247**	Convergence	1,062	-
Asia	-0,282**	Convergence	2,068**	Divergence
Africa	-0,182	-	1,651	-
Americas	-0,543***	Convergence	1,622	-

Summing up, we can confirm that there is strong beta-convergence when technical agricultural production effectiveness indicators are taken into consideration. However differences in the value of production yields in years 1992-1994 was so large, that despite beta-convergence occurrence we cannot find any noteworthy signs of sigma-convergence. Probably it takes years to detect the fall of yields dispersion across countries and the occurrence of sigma-convergence.

### 3.2. The share of employment in agriculture

One of the most important indicator of agricultural development is the fall of the employment in agriculture as a share of total employment in given country. For every economy it is better to employ as small fraction of total labor force as possible, since the labor productivity in non-agricultural sectors is higher than in agriculture (Foster Rosenzweig 2008). Only in 10 out of 131 analyzed countries the share of employment in agriculture grew in the analyzed sector, mostly in Asian and African region. However only in Zimbabwe and Guatemala this growth was significant. In other countries strong decline in employment in agriculture was observed. Moreover, the bigger share of agricultural employment at the beginning of analyzed period, the more explicit fall in the following years.

*Table 4: The share of employment outside agriculture convergence analysis between  
 years 1992-1994 and 2014-2016  
 (own elaboration on the WORLDBANK data basis)*

	β-convergence		Σ-convergence	
	b coefficient	Decision	$S^2_{(14-16)}/S^2_{(92-94)}$	Decision
World	-0,304***	Convergence	0,300***	Convergence
Europe	-0,549***	Convergence	0,380***	Convergence
Asia	-0,495***	Convergence	0,399***	Convergence
Africa	-0,169***	Convergence	0,399***	Convergence
Americas	-0,352***	Convergence	0,410***	Convergence

The results of beta- and sigma-convergence analysis presented in table 4. confirm this observation. For every region and globally beta- and sigma-convergence was proven. The pace of the convergence processes was the highest for European and Asian countries and the lowest for African countries. Also the dispersion of the analyzed indicator is declining significantly within last years for every region and worldwide. It is worth to mention that as it can be concluded from the title of table 4 the subject of the analysis was not the share of agricultural employment but its opposite, since convergence analysis technique employed in this paper are the best designed to measure the growth of specific indicator, not the fall.

### 3.3. The level of value added in agriculture

The last indicator of the agricultural growth is the level of value added per worker in agriculture. Taking into account that in all previous indicators beta-convergence was observed, one can presume that it will also be the case for the value added per worker.

However as it can be seen in table 5, globally there is statistically significant beta-divergence in changes of value added per employed in agriculture. Only in region called »Americas«, which consists of countries from Northern and Southern America, where no convergence or divergence was confirmed and in Europe there were no beta-divergence. It means that worldwide and also in Asia and Africa the higher value of initial value added in agriculture the biggest the percentage growth of this indicator. And even for Europe and Americas one can observe strong sigma-divergence.

*Table 5: The Value Added per worker in agriculture convergence analysis between years 1992-1994 and 2014-2016 (own elaboration on the WORLDBANK data basis)*

	β-convergence		Σ-convergence	
	b coefficient	Decision	$S^2_{(14-16)}/S^2_{(92-94)}$	Decision
World	0,137***	Divergence	2,117***	Divergence
Europe	-0,256***	Convergence	3,064***	Divergence
Asia	0,211***	Divergence	3,244***	Divergence
Africa	0,332***	Divergence	2,964***	Divergence
Americas	0,064	-	3,621***	Divergence

These results implies that although there are strong convergence processes in the agricultural sector development globally, the level of the labor effectiveness in agriculture still remains diversified across countries and even getting more and more heterogeneous last years. It is especially truth for African countries. Even when only European countries are taken into account the dispersion of the value added per worker in agriculture grows. It is also worth to mention that beta-convergence in Europe is caused mostly by members of European Union, where the Common Agricultural Policy helps farmers in poorer countries to get satisfying level of capital. In other parts of the world growth of the diversification of technical equipment in the agricultural holdings makes value added per worker in agriculture more heterogeneous.

#### 4. CONSLUSION

The main aim of this paper was to assess whether there are convergence processes in the agricultural sectors worldwide. The simple agricultural production effectiveness indicators analysis shows that globally agricultural sectors effectiveness is getting more uniform. Although the differences in production yield at the beginning of the last decade of XX century was high enough to inhibit the occurrence of sigma-convergence, beta-convergence of agricultural productivity is common phenomenon in world economy. The development of agricultural sectors is also easily visible when convergence of share of employment in agriculture is analyzed. In every analyzed region and globally the employment in agriculture as a share of total employment declines and the highest initial rate the biggest drop is observed. However there are beta-convergence in agricultural production effectiveness and beta- as well as sigma-convergence in agricultural employment, still the value added per worker in agriculture is getting more and more diverse in today's world. The main reason for this paradox is probably rising diversion of capital equipment in agricultural holding worldwide. Not only sigma-divergence but also beta-divergence is observed when the value added per worker in agriculture is analyzed. The only exception is Europe, mostly due to convergence processes inside the European Union.

## LITERATURE:

1. Abdollahzadeh G., Kalantari K., Asadi A., Fisher R., Daneshvar Ameri Z., (2012). Spatial Patterns of Agricultural Development: Application of the Composite Index Approach (A Case Study of Fars Province). *Journal of Agricultural Science and Technology*, Vol. 14, 51-64.
2. Barro, R. J., Sala-i-Martin, X. (1992). Convergence. *Journal of political Economy*, 223-251.
3. DeConti G., Patterson I., Spencer C., (2017) Agricultural Productivity Indicators and Economic Inequality in Sub-Saharan Africa. Swansea: UWTSD Group. Retrieved: 12.10.2018 from [https://www.conftool.com/icabr2018/index.php/DeConti-Agricultural\\_Productivity\\_Indicators\\_and\\_Economic\\_Inequality-391\\_a.pdf?page=downloadPaper&filename=DeConti-Agricultural\\_Productivity\\_Indicators\\_and\\_Economic\\_Inequality-391\\_a.pdf&form\\_id=391&form\\_version=final](https://www.conftool.com/icabr2018/index.php/DeConti-Agricultural_Productivity_Indicators_and_Economic_Inequality-391_a.pdf?page=downloadPaper&filename=DeConti-Agricultural_Productivity_Indicators_and_Economic_Inequality-391_a.pdf&form_id=391&form_version=final).
4. Foster, A.D., Rosenzweig, M.R., (2008). Economic Development and the Decline of Agricultural Employment. *Handbook of Development Economics*, Elsevier, 3051-3083.
5. Gollin D., Parente S., Rogerson R., (2002). The Role of Agriculture in Development. *American Economic Review*, 92 (1), 160-164.
6. Jones C., (2008). *Macroeconomics*. New York USA: W.W.Norton Company.
7. Kusideł E. (2013). *Konwergencja gospodarcza w Polsce i jej znaczenie w osiągnięciu celów polityki spójności*. Łódź: Wydawnictwo Uniwersytetu Łódzkiego.
8. Majchrzak A., Smędzik-Ambroży K. (2014). *Procesy konwergencji dochodów gospodarstw rolnych w Polsce po 2006 roku*. *Journal of Agribusiness and Rural Development* 1 (31), 89-98.
9. Olsson, O., Hibbs D.A. (2005). Biogeography and Long-Run Economic Development. *European Economic Review*, 49 (4), 909-938.
10. Olujeny F.O. (2006). Impact of Agricultural Development Programme (ADP) On the Quality of Social Existence of Rural Dwellers in Developing Economies: The Ondo State (Nigeria) Agricultural Development Programme Experience. *International Journal of Rural Management*, 2(2), 213-226.
11. Sabouri M.S., Solouki M. (2015). Factor Analysis of Agricultural Development Indicators from Iranian Agriculture Experts' Viewpoints. *International Journal of Agricultural Management and Development*, 5(3), 245-255. Retrieved 23.09.2018 from [http://ijamad.iaurasht.ac.ir/article\\_515632\\_ecda5224552a36b2cf2ad9a2e57f9198.pdf](http://ijamad.iaurasht.ac.ir/article_515632_ecda5224552a36b2cf2ad9a2e57f9198.pdf).
12. Siljak D. (2015). Real economic convergence in the European Union from 1995 to 2013. *The Business and Management Review*, Volume 6, Number 4, 213-225.
13. Siudek T. (2007). Impact of agricultural development on economic and financial situation of cooperative banks in Poland. *Problems of World Agriculture*, vol. 1(16). 69-79.
14. Solow, R. (1956). A Contribution to The Theory of Economic Growth. *Quarterly Journal of Economics*, Vol.70 (1), 65-94.
15. Thirtle, C., Lin L., Piesse J. (2003). The Impact of Research-led Agricultural Productivity Growth on Poverty Reduction in Africa, Asia and Latin America. *World Development*, 31 (12), 1959-1975.

## IMPLEMENTATION OF FLEXICURITY THROUGH CORPORATE SOCIAL RESPONSIBILITY

**Kristina Afric Rakitovac**

*Juraj Dobrila University of Pula,  
Faculty of Economics and Tourism "Dr. Mijo Mirković" Pula, Croatia  
kafric@unipu.hr*

**Marija Buselic**

*Juraj Dobrila University of Pula,  
Faculty of Economics and Tourism "Dr. Mijo Mirković" Pula, Croatia  
mbusel@unipu.hr*

### ABSTRACT

*The purpose of the paper is to present the employers' attitudes regarding flexicurity in the labour market in Croatia. The companies were selected among the winners of the CSR Index, i.e. a methodology for evaluating the implementation of the concept of corporate social responsibility (CSR) in the Croatian economy, proposed by the Croatian Chamber of Economy and the Croatian Business Council for Sustainable Development in 2008. In the period from 2008 until 2017, 38 companies were awarded for their successful implementation of CSR. 31.6% of them accepted the invitation to participate in the research. The main research hypothesis was that CSR companies are aware of, and are already implementing the principles of flexicurity in their business practice. The research has confirmed the readiness of CSR awarded companies in Croatia to implement measures that improve their working environment, resulting in many business benefits for the company, and, at the same time, contribute to flexicurity of the Croatian labour market.*

**Keywords:** *labour market, flexicurity, corporate social responsibility, EU, Croatia*

### 1. INTRODUCTION

The concept of flexicurity implies integrated strategies addressed at improving flexibility and security in the labour market. It is one of the key elements of the European Union's employment policy. The labour legislation and policies in Croatia are only formally adjusted to the EU requirements, but the implementation still represents a challenge for various stakeholders in the labour market. The paper observes the implementation of flexicurity through the concept of corporate social responsibility. The empirical research is part of the scientific project "Flexicurity and corporate social responsibility: A comparative analysis of the labour markets in Croatia and Slovenia", financed by the Juraj Dobrila University of Pula, Faculty of Economics and Tourism "Dr. Mijo Mirković". The main goal of the project is to analyse the key aspects of the concepts of flexicurity in the labour markets of Croatia and Slovenia, to analyse the interdependence between the concepts of flexicurity and corporate social responsibility, and to propose the guidelines for more intensive implementation of discussed concepts in the observed markets. The project is organised in six phases. The aim of the first phase was the analysis of theoretical determinants of the interdependency of the concepts of flexicurity and corporate social responsibility. The aim of the second phase was to analyse attitudes of relevant stakeholders (employers, the representatives of the relevant ministries and unions) in both countries regarding the flexicurity of their labour markets. The empirical research is organised in two parts: the analysis of employers' attitudes regarding flexicurity through a survey method and individual interviews with the representatives of the employers' associations, the relevant ministries and unions. The results of the survey proposed to employers are presented in this paper. The purpose of the paper is to present the employers' attitudes



regarding flexicurity in the labour market in Croatia. The companies were selected among the winners of the CSR Index, i.e. a methodology for evaluating the implementation of the concept of corporate social responsibility (CSR) in the Croatian economy, proposed by the Croatian Chamber of Economy and the Croatian Business Council for Sustainable Development in 2008. In the period from 2008 until 2017, 38 companies were awarded for their successful implementation of CSR. 31.6% of them accepted the invitation to participate in the research. The main research hypothesis was that CSR companies are aware of, and are already implementing the principles of flexicurity in their business practice. The research has confirmed the readiness of CSR awarded companies in Croatia to implement measures that improve their working environment, resulting in many business benefits for the company, and, at the same time, contribute to flexicurity of the Croatian labour market.

## **2. FLEXICURITY IN THE CONTEXT OF CORPORATE SOCIAL RESPONSIBILITY**

The concept of flexicurity implies integrated strategies addressed at improving flexibility and security in the labour market. It includes moderate legal protection of employment, a high level of employees' participation in lifelong learning, abundant subsidies in case of unemployment, efficient social safety net and a high rate of employees joining a union. The implementation of flexicurity should result in significant changes in the labour market, higher productivity, flexibility and security at the local, regional and national levels. The concept of flexicurity is one of the key elements of the European Union's employment policy. In accordance with the European strategy Europe 2020: A strategy for smart, sustainable and inclusive growth, each country is expected "to implement their national pathways for flexicurity, as agreed by the European Council, to reduce labour market segmentation and facilitate transitions as well as facilitating the reconciliation of work and family life" (European Commission, 2010). Therefore, various stakeholders from the EU labour market are faced with many challenges related to flexicurity. The Danish "golden triangle", implemented since 2013, is usually proposed as one of the best examples of successful implementation of the concept. It is based on flexible regulatory conditions, an appropriate level of income security for unemployed persons and active measures of fostering prequalification and employability (Bušelić, 2017). The model of flexicurity requires the transition from the known concept of job security to more sustainable concept of work security and long-lasting employability. Employers require flexible work force ready to adapt to changes and lifelong learning, while employees need more income security during the process of searching for new employment. A relatively small number of empirical scientific researches and measuring of flexicurity in the labour market can be explained with the lack of a common definition, the multidimensional importance of the concept and the wide range of potential indicators. The scientific papers are mainly focused on creating appropriate flexicurity indicators (Tangian, 2004; Tagian 2006; EC, 2007; European Foundation, 2007), on selected components of flexicurity (Bernal-Verdugo, Furceri and Guillaume, 2012; Dosi et al., 2017; Kahn, 2010; Cournède, Denk and Garda, 2016; Algan and Cahuc, 2006), while some elaborate the process of measuring flexicurity (Tros, 2012 and Chung, 2012) through identifying the most relevant indicators (from: Ostrovidov Jakšić, 2017: 44). In order to identify different safety policies, Wilthagen and Tros (2004) have constructed a matrix embracing all dimensions of flexicurity and security, proposing 16 different combinations which should result in a win-win situation in the labour market. The labour legislation and policies in Croatia are only formally adjusted to the EU requirements, but the implementation still represents a challenge for various stakeholders in the labour market. The analyses of the labour market indicate that the regulation is rigid, constraining economic development and that it hinders solving problems related to unemployment. The Danish model of flexicurity could be partially implemented in Croatia, but only under the conditions of a wider implementation of active labour market policy, decreased need for measures of passive

labour market policy, readiness of relevant stakeholders to promote and implement life-long learning, combating the shadow economy and undeclared work, etc. Recent researches on flexicurity in Croatia were conducted by Bilić and Perkušić (2016), Perin (2013), Laleta, Bodiřoga and Vukobrat (2016) and Bušelić (2017). The concept of corporate social responsibility (CSR) has become increasingly present in the business practice and in different scientific and professional analyses. It is a self-regulatory instrument whose implementation results in numerous benefits for the business community, and, at the same time, for the social community and the environment. Often, CSR is recognised as an important factor of fostering competitiveness at the level of a particular business subject, but also at the mezzo and macro levels. The precondition for a successful implementation of the concept is, *inter alia*, the knowledge about the features, possibilities and benefits of CSR for internal and external stakeholders. The concept of CSR exists from the very beginning of the development of market economy and the first companies as economic subjects. However, the concept of CSR as a specific term has been widely used since the 1960s. The understanding and implementation of the concept has changed and developed from that period in the business and academic community. The implementation of CSR has its stronghold in the etymology of the English word 'company'. It derives from two Latin words *com* and *panis* which mean breaking bread together (Arndt, 2003 in: Asongu, 2007). It clearly indicates the idea that a company as a business subject has a social dimension. As a business philosophy, CSR pinpoints even more the responsibility of the company towards its employees, the community it operates in, and the company's direct and indirect environmental impact. Understanding and implementing CSR is different in various countries due to different levels of economic development, legislation, tradition, cultural values, ethical norms, etc. One of the most frequently used definitions of CSR is the one proposed by the World Business Council for Sustainable Development (WBCSD), defining CSR as "continuing commitment by business to contribute to economic development while improving the quality of life of the workforce and their families as well as of the community and society at large" (O'Holiday, 2002). A responsible company can be described as being coherent, fair, transparent, ethical and responsible in realising business activities by taking into account its own interests, the interests of various internal and external stakeholders, and the impact on the local community, society and environment. Flexicurity addresses the concept of CSR in its dimension related to the company's working environment. CSR companies are implementing responsible policies and practices in the working environment, conducting responsible employment policy, adequately valorising working results, investing in education and employee's employability, quality assurance, safe working places, and the creation and implementation of collaborative organisational climate. The continuous commitment of CSR companies towards creating a responsible working environment is interrelated with the concept of flexicurity. It can be concluded that there are linkages between CSR and flexicurity of the labour market, especially in lifelong learning, employee's participation in a union, employing persons with problematic employability (e.g. young unemployed people without the working experience, the long-term unemployed, the unemployed with disabilities, etc.). From the analysis of available empirical researches, it can be concluded there is a lack of studies which would contribute to understating the significance of the concept of flexicurity for various stakeholders (employers, governments, unions) as well as the role of socially responsible employers in creating the labour market which implements flexicurity.

### **3. EMPIRICAL RESEARCH**

#### **3.1. Research methodology**

The aim of the empirical research was to analyse the importance of flexicurity for companies selected according to the CSR Index, i.e. a methodology for evaluating the implementation of

the concept of corporate social responsibility in the Croatian economy, proposed by the Croatian Chamber of Economy and the Croatian Business Council for Sustainable Development in 2008. There are three types of questionnaires: one for large and medium companies, another for small companies, and the third for public companies. The questions are divided in six groups: economic sustainability; inclusion of CSR into the business strategy; working environment; environmental protection; market relations and relations with the community. In the period from 2008 until 2017, there were 38 companies awarded for their successful implementation of CSR. The main research hypothesis was that CSR companies are aware of, and are already implementing the principles of flexicurity in their business practice. The research instrument was a questionnaire consisting of 16 questions, partially based on the section "working environment" from the previously mentioned methodology. The research was performed in May 2018. 38 companies, awarded for successful implementation of CSR in the period from 2008 to 2017, were invited to participate in the research. Twelve companies, i.e. 31.6% have accepted the invitation. The primary data was obtained by telephone interviews, based on the previously sent instructions. Although the sample is relatively small, the research results indicate the importance that CSR companies give to responsible policies and practices in the working environment which promotes flexicurity. The paper presents selected questions and answers. The data have been analysed by methods of descriptive analysis and, when appropriate, the One-way ANOVA analysis, processed with the SPSS programme 24.0.

### 3.2. Research results

The first group of questions was related to the characteristics of the observed companies. Regarding the size of the observed companies, there were five large companies, three middle-sized and four small. From the sectoral perspective, two were from the secondary sector (manufacturing industry) and nine from the service sector. Considering the period of the firm's activity, six companies have been in the market for more than 25 years, three companies for a period from 11 to 15 years, two companies from 16 to 25 years, and one for a period from one to five years. As regards the ownership structure, ten companies are in the private sector, while two companies are in the public sector. Considering the type of market in which the company operates, five companies operate on the national market, three companies on the local and regional markets, and three on the national, EU and international markets. The research instrument was mainly fulfilled by the general manager in small firms, or by managers related with CSR, human resource management or public relations in middle-sized and large companies. The second group of questions was related to the implementation of various elements of flexicurity in the business process. The first question was related to the types of education offered to employees in the last five years (Table 1). It can be concluded that the most frequently used measures are those related to flexicurity, i.e. measures related with training for acquiring new knowledge and skills, followed by training on workplace safety, while the least used measures are related to environmental protection, business ethics and relations with the local community.

*Table 1: Types of education offered to employees by observed companies in the last five years*

<b>Types of education</b>	<b>No. of companies</b>
<b>Education on labour regulations</b>	6
<b>Trainings on workplace safety</b>	11
<b>Trainings for acquiring new knowledge and skills</b>	12
<b>Business ethics</b>	4
<b>Enforcing communication capabilities</b>	7
<b>Environmental protection</b>	3
<b>Relations with the local community</b>	5

*Source: Authors' research*

Examinees have also mentioned education on some other relevant topics offered to employees in the observed period: risk management, implementation of new systems, PhD and specialist postgraduate studies, hackathons, scrum and agile project management, etc. The second question was related to the gender structure of employees in the observed companies. The results show that 67.3% of the total number of employees are male, while 32.7% are female. The next question was related to the share of female employees in the management board and high management in the observed companies. The results show a wide range of answers, from 0% (in 25% of the sample) to 100% (in 16.7%), with an average of 36.7%. In the context of the concept of flexicurity, it is interesting to note that one quarter of the companies employ persons with problematic employability. The structure of employed persons from this group is as follows: 75% of the observed companies employ persons without working experience, 50% of them employ persons above the age of 50, 25% of them employ persons with physical disabilities, while 12.5% of them employ long-term unemployed persons. It can be concluded that the observed companies contribute to the inclusion of those persons, previously excluded from the labour market, in the economic activity. The next question was related to the implementation of measures aimed at improving the quality of life and health protection of employees. The most frequently used measure, used by 75% of companies, is related to mental health support, followed by general medical examinations (50%) and specialised examinations (50%), physical training (41.7%) and ergonomic working conditions (16.6%). Examinees have also mentioned other activities: motivation of employees for active participation in various sports activities; participation in the global project "Global Challenge" as an incentive to physical activities, organised and paid by the company; leisure time activities related to team building; incentives related to certain music activities; medical doctor and an infirmary situated in the company's building, etc. The next question was related to the benefits and measures that contribute to improving the quality of the employees' family life (Table 2). The most frequently offered benefits and implemented measures are those related to flexible working hours, occasional homeworking, avoiding meetings in the late afternoon/evening and giving priority to employees with children while planning annual leave. As expected, the least used measure was the company's kindergarten.

*Table 2: Benefits and measures that contribute to improving the quality of employees' family life*

<b>Measure</b>	<b>Answers (multiple choice, in %)</b>
<b>Flexible working hours</b>	83.3
<b>Occasional homeworking</b>	66.6
<b>Avoiding meetings in the late afternoon/evening</b>	66.6
<b>Giving priority to employees with children while planning annual leave</b>	66.6
<b>Possibilities for employees' children visiting the company</b>	50.0
<b>Organisation of performances for children</b>	33.2
<b>Possibilities for family members to participate in specific events at the company</b>	33.2
<b>Breastfeeding at work</b>	33.2
<b>Company's kindergarten</b>	16.6

*Source: Authors' research*

Examinees have also mentioned other benefits and measures, such as: complete flexibility in planning annual leave; flexible working time in cases of exceptional situations in the employees' family; loans offered by the company without interest-rate; financial support to parents with children with disabilities, etc.

All these measures indicate a clear commitment of observed companies towards supporting the quality of family life of their employees, as a precondition for their productivity, innovativeness and creativity. The following question was related to the frequencies of methods of restructuring used in observed companies in the last five years (Table 3).

*Table 3: Methods of restructuring implemented in the company in the last five years*

Answer	Frequencies					Arithmetic mean	Stv.dev.	Skewness
	Frequently	Sometimes	Never	Rarely	Very rarely			
<b>Financial restructuring</b>	4	2	0	2	4	3.00	1.809	0.000
<b>Operative restructuring</b>	6	0	3	2	1	3.67	1.497	-0.484
<b>Strategic restructuring</b>	4	1	5	1	1	3.50	1.314	-0.288
<b>Fixed costs reduction</b>	1	4	4	3	0	3.25	0.965	0.136
<b>Variable costs reduction</b>	3	3	3	3	0	3.50	1.168	0.000
<b>Employee reassignment</b>	6	4	0	0	2	4.00	1.477	-1.625
<b>Adjustment of work volume and working time without personnel layoff</b>	6	2	2	1	1	3.92	1.379	-1.072
<b>Personnel layoff</b>	0	0	0	3	9	1.25	0.452	1.327
<b>Increasing the quality of products and services, production and business processes</b>	7	2	2	1	0	4.25	1.055	-1.149
<b>Activities aimed at acquiring new customers</b>	8	3	1	0	0	4.58	0.669	-1.455

*Source: Authors' research*

The most frequently used measures were those related to activities aimed at acquiring new customers and those related to increasing the quality of business processes, production, products and services. The least used measure was related to personnel layoff. Examinees have also mentioned other methods of restructuring implemented in the last five years: innovations, introduction of new systems and platforms aimed to optimise and digitalise the business processes, intensive strategic planning in all business sectors, permanent market analysis and adaptation to new situations, competitors and trends, etc.

It can be concluded that the observed companies are socially responsible regarding their employees, trying to retain their employees through measures of employee reassignment, another important aspect of flexicurity. In the following question, 75% of examinees agree that there is high protection of employees' rights by the labour law in Croatia. The examinees explained that, in cases of unsatisfactory working results, the process of cancelling an employment contract was long and demanding, resulting in a settlement between the employer and the employee in the majority of cases. Also, one third of examinees pointed out that, in many cases, the employees are more protected than the employer. The labour legislation should be more flexible in cases of firing unproductive employees. It can be concluded that the relatively rigid labour legislation is a significant barrier to a more intense implementation of flexicurity. In the next question, the examinees were asked to recognize the most problematic aspect of legal protection of employees in Croatia. 66.7% of them agree on limitations related to the process of firing employees, 25% of them consider the regulation not to be problematic, while 8.3% consider the firing notice period to be a problematic aspect. Regarding the implementation of measures of active employment policy proposed by the Croatian Employment Service, 91.7% of companies use them. The most frequently implemented measures were subsidies for employing unemployed persons (19.1%), subsidies for professional training (17.9%), professional training without employment (15.5%), apprenticeship (11.9%), hiring permanent seasonal workers (11.9%), training employees at the working place (10.7%), training for achieving working experience for those older than 30 (6.0%), and subsidies for preserving employment (6.0%). The possibility of flexible working hours is offered in 91.6% of the observed companies. Part-time employment is offered by 66.7% of the companies, while job sharing practice is offered in 41.7 % of the observed companies. In the next question, the examinees were asked about having a strategy for life-long learning aimed at continuous adaptability, flexibility and employability of their employees. Two-thirds of the observed companies have implemented it. In the last question, the examinees were asked whether they support a stricter regulation of flexicurity through labour legislation in Croatia. It was supported by 91.7% of the observed companies. The results of the empirical research confirmed the research hypothesis, i.e. the observed companies are taking into account the lifelong learning of their employees, the quality and motivating working environment, the quality of life of their employees and their families. As observed in the empirical research, the most frequently used measure of restructuring in the observed companies, in the segment of working relations, was employee reassignment, rarely layoffs. Most employers have pointed out the legislation rigidity, even in cases of firing low-productive employees. Almost all examinees confirmed the need of stricter regulation of flexicurity through labour legislation in Croatia.

#### **4. CONCLUSION**

Today, each EU member state is implementing a proper set of institutions and policies, resulting in a certain level of flexicurity. There is not only one strategy of flexicurity that would be applicable in all countries. The principles of flexicurity proposed by the European Commission could be a useful landmark. The principles can be implemented through four elements, taking them as a whole: flexible and confident working relations, efficient active labour market policy which should enforce security during job transition, systematic and responsible lifelong learning and efficient social safety net. A necessary precondition for an efficient flexicurity system is also efficient social dialog and a high level of collective working relations based on trust. The necessary precondition for fostering the implementation of flexicurity in the Croatian labour market is the collaboration of key stakeholders (employers, government, unions) on possible measures which should result in a more flexible legislation while ensuring secure employment.

The main research hypothesis, stating that CSR companies are aware of, and are already implementing the principles of flexicurity in their business practice, was confirmed through empirical research presented in the paper. The research has confirmed the readiness of CSR awarded companies in Croatia to implement measures that improve their working environment, resulting in many business benefits for the company, and, at the same time, contribute to flexicurity of the Croatian labour market. The limitations of the research are related to a very small sample of observed companies, although recognised as CSR companies. The next researches should enlarge the research sample and compare the implementation of flexicurity principles in CSR and non-CSR committed companies.

#### LITERATURE:

1. Asongu, J.J. (2007). *Sustainable Development as a Business Responsibility*. Journal of Business and Public Policy. Volume 1. Number 1. Winter 2007
2. Bernal-Verdugo, L.E.; Furceri, D.; Guillaume, D. M. (2012). *Labour Market Flexibility and Unemployment: New Empirical Evidence of Static and Dynamic Effects*. March 2012. IMF Working Paper No. NO.12/64.
3. Bilić, A. and Perkušić, T. (2016). *Employment contract for a definite period of time as a modus of implementing flexibility on the labour market*, Mostariensia : časopis za društvene i humanističke znanosti, Vol.20 No.1-2 December 2016. Retrieved 15.03.2018 from <https://hrcak.srce.hr/170907>
4. Blewitt, J. (2017). *Razumijevanje održiva razvoja*, IRMO, Zagreb
5. Bušelić, M. (2017). *Suvremeno tržište rada*, Juraj Dobrila University of Pula
6. Dosi, G. et al. (2017). *When More Flexibility Yields More Fragility: The Microfoundations of Keynesian Aggregate Unemployment*, Journal of Economic Dynamics and Control, 81, str. 162-186. Retrieved 15.06.2017 from: <http://spire.sciencespo.fr/hdl:/2441/9d007rc2q9huruni0kde2vr73/resources/wp2016-07-dosiwhen-more-flexibility.pdf>
7. European Commission. (2010). *EUROPE 2020 A strategy for smart, sustainable and inclusive growth*. Communication from the Commission COM(2010) 2020. Brussels, 3.3.2010. Retrieved 10.03.2018 from <http://ec.europa.eu/eu2020/pdf/COMPLET%20EN%20BARROSO%20%20%20007%20-%20Europe%202020%20-%20EN%20version.pdf>
8. Kotler, P.; Lee, N. (2004). *Corporate Social Responsibility: Doing the Most Good for Your Company and Your Cause*, Wiley
9. Laleta, S.; Bodišić and Vukobrat, N. (2016). *Fleksigurnost i (de)regulacija tržišta rada*. Zbornik Pravnog fakulteta Sveučilišta u Rijeci, Vol.37 No.1 Travanj 2016. Retrieved on 20.03.2018 from <https://hrcak.srce.hr/160467>
10. Laporšek S., Dolenc P. (2011). *Do Flexicurity Policies Affect Labour of their labour market reforms?* Oxford Economic Papers, 56(4), 621-642. doi:10.1093/oep/gpf057 of Economics, 100(1), 113-141. Retrieved on 10.03.2018 from doi: 10.3935/rsp.v19i2.1018
11. O'Holiday, Jr C. et al (2002). *Walking the Talk – The Business Case for Sustainable Development*, World Business for Sustainable Development, GreenLeaf Publishing
12. Ostrovidov Jakšić, A. (2017). *Postoji li mogućnost primjene koncepta fleksigurnosti na tržište rada u Republici Hrvatskoj?* Privredna kretanja i ekonomska politika, God. 26 br. 1 (140)
13. Perin, V. (2013). *Strukovno obrazovanje i tržište rada: koncept fleksigurnosti*, Život i škola: časopis za teoriju i praksu odgoja i obrazovanja, Vol.LIX No.30 December 2013. Retrieved 15.04.2018 from <https://hrcak.srce.hr/131976>
14. Scharmer, O., Kaufer, K. (2016). *Voditi iz nadolazeće budućnosti, Prijelaz ekonomije iz egosustava u ekosustav*, Planetopija, Zagreb

15. Tangian, A. S. (2004). *Defining the flexicurity index in application to European countries*. WSI-Diskussionspapiere, No. 122.
16. Tangian, A. S. (2010). *Not for bad weather: Macroanalysis of flexicurity with regard to the crisis*. ETUI Working Paper, 2010.06. Cingano 2010
17. Wilthagen, T., & Tros, F. (2004). *The concept of 'flexicurity': A new approach to regulating employment and labour markets*. Transfer: European Review of Labour and Research, 10(2), 166-186. Retrieved 20.04.2018 from doi:10.1177/102425890401000204



## COUNTRY OF ORIGIN IN FASHION INDUSTRY – A LITERATURE REVIEW

**Paula Gargoles Saes**

*PhD Candidate, ISEM Fashion Business School, Spain  
paula.gargoles@isem.es*

**Lana Lovrencic Butkovic**

*Assistant Professor, University of Zagreb, Faculty of Civil Engineering  
llovrencic@grad.hr*

**Alica Grilec**

*Assistant Professor, University of Zagreb, Faculty of Textile Technology  
alica.grilec@tjf.hr*

### **ABSTRACT**

*In order to understand more the value of the Country of Origin (COO) in the fashion industry and the effect in the brand image and also consumer perceptions and purchase intentions, recent studies have highlighted the importance of considering the label “Made in” in the clothing field. The fast fashion is mostly produced in Asia, in countries like Vietnam or Bangladesh, while the luxury brands are producing in Europe with the label “Made in Italy” or “Made in France”. The trend of local production is also growing, while the new Chinese consumers are looking for the sophistication of the Western countries. Thus, in order to provide guidance for future research related to country of origin and fashion, the present paper aims at reviewing existing research and synthesizing main approaches and findings. In particular, this review seeks to screen existing studies published in period 2009-2017 using Science Direct and Scopus database with the following keywords: Country of Origin and Fashion, with regard to their a) effect of the country of origin b) research focus, c) type of study/paper, d) the sample used, e) analyzed relationships, and f) the different types of fashion items which are covered and linked with country of origin.*

**Keywords:** *Country of Origin, fashion, brand image*

### **1. INTRODUCTION**

Highly competitive fashion market and a constant need to satisfy the latest needs of consumers pushed fashion brands to think about all attributes that can influence consumer decision to buy certain fashion product. In 1962 Ditcher already introduced the concept of Country of Origin and explained its importance in success of the products (Capelli et al., 2017). Later, researches documented that there is a preferential treatment to domestic products against foreign and that “foreignness” makes products less preferable to consumers in various countries (Balabanis & Diamantopoulus, 2004). Also, Country of Origin became very significant as it effects consumer product evaluation, buying decisions and considering the fact that consumers prefer products from Country of Origin that has a more favourable country image (Aichner, 2013, p. 1). For already 50 years The Country of Origin has been a central topic in the international marketing research literature (Andéhn et al., 2015, p. 225). Although it is highly researched international aspect of consumer behavior (Aichner, 2013), there is still lack of comprehensive literature review that reviews Country of Origin in context of fashion industry, so the aim of this paper, in order to provide guidance for future research related to value of country of origin in fashion industry, is to review existing research and synthesize main approaches and findings. In particular, this review seeks to screen existing studies published in period 2009-2017 using Science Direct and Scopus database with the following keywords: country of origin and fashion,

with regard to their a) effect of the country of origin b) research focus, c) type of study/paper, d) the sample used, e) analyzed relationships, and f) the different types of fashion items which are covered and linked with country of origin. The paper is organised in four sections. In Section 2 the country of origin is briefly described and some definitions of it are examined. Section 3 presents matrix with all available researches with country of origin in its focus, while Section 4 presents the conclusions of literature review according to the defined criteria and main future research directions are presented.

## 2. THE COUNTRY OF ORIGIN

The country of origin of a product, which is typically operationalized or communicated through the phrase "Made in \_\_\_\_\_," is an extrinsic product cue - an intangible product attribute - that is distinct from a physical product characteristic or intrinsic attribute (Peterson and Jolibert, 1995, p. 884). As such, a country of origin (i.e., COO) cue is similar to price, brand name, or warranty in that none of these directly bear on product performance. There are many definitions of COO that could be found in the literature and some of them are shown in Table 1.

*Table 1: A sample of definitions of country of origin*

<b>Author</b>	<b>Definition</b>
Phau, I., & Cheong, E. (2009, p. 6)	<i>COO is the country where the corporate headquarter of a company marketing a product or brand is situated. Typically the brand origin is attached to a brand name, even if the product is not designed, manufactured or assembled in that country (Lim &amp; O'Cass 2001; Mort &amp; Duncan 2003; Samiee 1994; Thakor &amp; Lavack 2003).</i>
Aiello et al. (2009, p. 325)	<i>The COO is commonly considered the country that consumers typically associate with a product or brand, regardless of where it was manufactured. Country of Manufacture (COM) was the country that appeared upon the 'made-in' label. It was represented as the country where the final assembly of a product was completed, and was identified as synonymous with the COO. The country-of-design (COD) refers to the country within which the product was designed and developed. Global companies use brand names to suggest a specific origin (country-of-brand – COB – effects).</i>
Lee et al. (2013, p. 67)	<i>Consumer ethnocentrism looks at the degree of loyalty of consumers to products manufactured in their home country and the responsibility and morality of purchasing foreign-made products (Shimp and Sharma, 1987). Consumer ethnocentrism may also lead to an overestimation of the attributes, features and overall quality of domestic products and an underestimation of such traits on foreign products (Netemeyer et al., 1991; Sharma et al., 1995; Kim and Pysarchik, 2000; Rawwas et al., 1996).</i>
Jung et al. (2014, p.189)	<i>Country Image (CI) refers to the totality of the descriptive, inferential, and informational beliefs one has about a particular country.</i>
Gerke et al. (2014, p. 177)	<i>The COO effect describes the notion that the COO is an informational cue extrinsic to the product which affects evaluation of the product, its attributes, and the consumer's overall perception of the product</i>
Tjandra, et al. (2015, p. 859)	<i>Country of Origin "as the image of a country in a consumer's mind which influences their evaluation of the products or brands that are produced by that country".</i>
Esmailpour & Abdolvand (2016, p. 711)	<i>The "COO" image is the picture, the reputation and/or the stereotype that businessmen and consumers attach to products of a specific country, as people in one country may prefer goods that originate from another country.</i>

*Source: authors*

For the long time, the effect of a product's COO on buyer perceptions and evaluations has been of big interest in the researches within the international business, marketing, and consumer behavior literature. The changing dynamics of the fashion industry, such as the fading of mass production, increase in number of fashion seasons, and modified structural characteristics in the supply chain have forced retailers to desire low cost and flexibility in design, quality, delivery and speed to market (Doyle et al., 2006). Due to this changes, many fashion brands moved their production in some less developed countries, such as Vietnam or Bangladesh, mostly because of cheaper work force. Lots of researches show that the country of origin effect influences the consumer's decision-making process in many ways (e.g. Phau and Cheong, 2009; Lee et al., 2013; Arora et al., 2015, Cheah et al., 2016). For example, some studies have shown that younger consumers are more favorable and purchasing more of foreign-made clothing over those that are made domestically (e.g. Jung and Sung, 2008; Phau and Yip, 2008; Kim et al., 2009; Chen, 2009). Other studies have shown fashion products from developed countries are being favored over those from less developed ones as they not only signify status, but are also of better quality, and more well known (e.g. O'Cass and Lim, 2002; Chan et al., 2007; Phau and Yip, 2008; Jin et al., 2010). Aiello et al. (2009) in their paper stated that the COO effect is not determinate in the perception of the consumer perception. Just in the luxury good, has a medium impact. The brand has more influence on the evaluation of the product and decision than the COO. But there are some studies that propose that as long as a product is associated with a well-known and respected brand name, it does not matter where it is made (e.g. Amine and Shin, 2002; Hui and Zhou, 2003). Lim and O'Cass (2001) stated that the brand origin is attached to a brand name, even if the product is not designed, manufactured or assembled in that country. This is also supported by Mort and Duncan (2003) paper. Rashid et al. (2016) study showed that COO is considered a strategic business issue that shows in different ways depending on brand positioning, long-term strategic plans, expertise and brand values. Today, in fashion industry more and more attention is paid to way of production, used materials, country of origin and so on. The trend of local production is also growing. So it is undeniable that the analysis of previous researches should contribute to a better understanding of perception and effects of country of origin in fashion industry and should be very useful for future researches.

### **3. BODIES OF LITERATURE ASSOCIATED WITH COUNTRY OF ORIGIN AND RESEARCHES IN FASHION INDUSTRY**

In this review, we didn't only focus on applying the content analysis to the literature, but we were also concerned with screening and describing the analytical details of existing studies in order to locate possible future research. The matrix shown in Table 2 has been obtained by combining these two dimensions and it will be used to summarize previous researches.

*Table following on the next page*

*Table 2: Country of origin content matrix*

<i>Author</i>	<i>Effect of COO</i>	<i>Research focus</i>	<i>Research method</i>	<i>Sample</i>	<i>Relationship</i>
Phau & Cheong (2009)	Neutral	Evaluate the brand loyalty effect in young consumers with 2 different COO: Italy and China	Empirical	739 young status consumers	Between diffusion brands and parent brands.  The conclusion is that there is no difference between the parent brand and its sub-brand made in the same COO: Italy and China.
Aiello et al. (2009, p. 325)	Neutral	Perception of the COO and of brands, and their influence on consumer perception and purchasing intention	Empirical	A statistically non-representative sample of 165 undergraduate management students	The COO effect is not determined in the perception of the consumer perception. Just in the luxury good, has a medium impact. The brand has more influence on the evaluation of the product and decision than the COO.
Riza Apil & Kaynak (2010)	Positive	Examine country of origin (COO) effects among Georgian consumers towards Germany, Italy and Poland	Empirical	313 consumers	Germany has the strongest image, Italy has a good image in the fashion products while Poland has the weakest image.
Godey et al. (2012)	Neutral	The combined effect of brand and COO on the purchasing decision of luxury products in 7 countries	Empirical	1 102 respondents from seven countries (China, France, India, Italy, Japan, Russia, and the USA)	COO plays a minor role, receiving a score below the mean for developed countries. However, consumers in all countries widely recognize brand as a criterion of choice in the purchase of luxury goods.
Parkvithee & Miranda (2012)	Positive	Examine the effect of interaction of COO, brand equity and product purchase involvement on consumers' evaluation and purchase preference of Thai brands of fashion apparel made in Japan, Vietnam and Malaysia	Empirical	540 participants	The COO and brands are affected by cross-border shifts of production among Japan, Vietnam and Malaysia.
O'Cass & Siahitiri (2013)	Positive	The impact of fashion clothing brands' status with origins from the West versus Asia in the Chinese young adults	Empirical	460 responses	The West fashion clothing brands have a better impact than the Asian because they communicate status and wealth for the Chinese young adults.
Lee et al. (2013)	Made in US and Australia has a positive effect, while made in China has a negative effect	Determine if high versus low ethnocentric consumers differ in their attitudes toward buying domestic and foreign brands of underwear that are made domestically or in foreign countries	Empirical	260 responses	There is no significant difference between high and low ethnocentric consumers in attitude towards underwear that are made in the US and in Australia.  On the other hand, China is perceived as lower performance and quality than in the US and in Australia.
Jung et al. (2014)	Positive	Identify the dimensionality of country image (CI) for luxury fashion brand and examine the multi-faceted impacts of CI on brand awareness, perceived quality, and brand loyalty	Empirical	466 responses	There are cultural discrepancies between the Korean and the USA samples, in which technological advancement is the determinant to increase luxury fashion brand awareness for the Korean group, while cultural asset and fashion equity are pertinent to enhance luxury fashion brand awareness for the US group.
Gerke et al. (2014)	Positive	The role of a firm's stakeholders in the analysis of brands, by including country-specific factors based on location and COO	Case study	A comparative case study using two case	The COO image together with sport product category-country associations enables the creation of brands in sport product categories.
Tjandra et al. (2015)	Positive	Understand the Generation Y's perceptions from advanced and emerging countries towards the COO of fashion products	Qualitative	53 interviews from 21 advanced and emerging economies	Generation Y consumers find fashion products made in advanced countries of better quality compared to those made in emerging countries.

Arora et al. (2015)	Positive	Examine the differences in consumer response to luxury parent brands versus their low-tier diffusion brands	Empirical	144 graduate (mostly employed) students from two southeastern U.S. Universities	When there is congruence between COO and COM, diffusion brands are preferred more than parent brands; in contrast, when there is incongruence between COO and COM, parent brands are preferred more than diffusion brands.
Esmailpour & Abdolvand (2016)	Positive	Explore how the COO image effects Generation Y's consumers toward luxury fashion brands	Empirical	419 responses	The perception of CCO in technology advancement has a positive effect of attitude toward luxury brands in the generation Y's consumer.
Liu et al. (2016)	Positive	Standardisation – localisation debate in the context of foreign luxury fashion retailers internationalisation into the Chinese marketplace	Qualitative	Using a phenomenological approach. 22 deep-interviews with senior marketing managers who are working in luxury fashion retail brands operating in China	Foreign luxury retailers in China need to balance the adaptation of the market conditions while maintaining a standardized western luxury image.
Cheah et al. (2016)	Positive	The influence of country-of-ingredient authenticity towards product judgment and how the construct influences the willingness to buy and recommend luxury branded products	Empirical	An experimental fixed-factor 2x2x2 between subjects factorial research design was developed	The importance of COO image as a trigger for positive product judgment, buying behavior and word of mouth intentions.
Rashid et al. (2016)	Positive	Conceptualising COO from a management perspective, identifying the impact different COO constructs have in the context of the fashion business	Qualitative	Eleven semi-structured interviews with key informants who represent ten major UK fashion brands	COO is considered a strategic business issue that shows in different ways depending on brand positioning, long-term strategic plans, expertise and brand values.
Cappelli et al. (2017)	Positive	Explore consumer behavior towards "Made in Italy" products to determine the associated quality and value-attributes related to the purchasing intention of consumers	Empirical	660 Italian citizens	"Made in Italy" is well established as a conceptual category in the minds of consumers and there is a significant "premium price" recognized by consumers for it in the sectors: food, fashion and furnishings.
Kim et al. (2017)	Positive	Analyzes how national stereotype, COO, and fashion brand's images influence consumers' brand evaluations and purchase intentions regarding fashion collections	Empirical	273 responses: 133 from Seoul, 90 from New York, and 50 from Paris	The countries with stronger COO and fashion brand images have a better impact on the consumers brand evaluations and stronger purchase intentions toward fashion collections.
Pucci et al., (2017)	Depends of the country	Understand whether the impact of country image and product-specific COO over the willingness to pay premium prices is different among consumers from different emerging countries	Empirical	2364 consumers belonging to 4 emerging countries (China, India, Thailand and Brazil) and the domestic country: Italy	In Italy, the higher willingness to pay for "Made In Italy" fashion products is positively related to the COO, while in China is only CI matters. In Thailand, the higher willingness to pay premium prices is negatively related to the CI, while it is positively related to the product-specific COO. In the Brazilian case, it is the opposite of Thailand.

Source: authors

As it can be seen from the matrix, 77,7% of the analyzed papers presented are empirical, 16,5% are qualitative and 5,5% are case studies. The effect of the COO is positive in the 72,2% of the papers, 16,6% are neutral and in the 11,1% depends of the country; for example, in one paper: "Made in US" and "Made in Australia" has a positive effect, while "Made in China" has a negative effect. An overview of the studies regard COO and Fashion is presented in Table 3.

Table 3: Country of origin in fashion industry research

<i>Project subject</i>	Luxury	Made in China	Made in Italy	Made in USA	Young consumers	Brand loyalty	Brand image	Purchase intentions	Consumer perceptions	Emerging countries	Country of manufacture	Ethnocentric consumers	Country Image
<i>Authors</i>													
Phau & Cheong (2009)	X		X	X	X	X							
Aiello et al. (2009)	X				X		X		X				
Riza Apil & Kaynak (2010)		X	X	X					X	X		X	X
Godey et al. (2012)	X	X	X	X			X	X		X	X	X	
Parkvithee & Miranda (2012)							X	X	X	X			
O'Casey & Siahtiri (2013)					X		X	X	X	X		X	
Lee et al. (2013)	X	X	X				X		X	X		X	
Jung et al. (2014)	X						X		X				X
Gerke et al. (2014)							X		X	X		X	
Tjandra et al. (2015)					X				X	X		X	
Arora et al. (2015)	X		X					X			X		
Esmailpour & Abdolvand (2016)	X				X	X	X	X	X				
Liu et al. (2016)						X	X						
Cheah et al. (2016)						X	X						
Rashid et al. (2016)						X	X						
Cappelli et al. (2017)													
Kim et al. (2017)							X	X	X				X
Pucci <i>et al.</i> , (2017)		X	X					X	X	X			

Source: authors

Summarized results about the COO and the fashion industry, show that the papers are more interested in the relationship between COO and Brand Image (66,6 %) and consumer perceptions (61,1%). The situation in the fashion in which usually is manufactured in emerging countries, is also a topic of research that cover the 44,4% of the papers.

#### 4. CONSLUSION

COO has been studied for many years but the intention of this review paper was to give an overview of the context and focus of previous COO studies in fashion context and to provide a reference guide for further research. Further research will aim to discover how COO is evaluated among Croatian fashion consumers and what is their attitude towards "Made in Croatia". Research question that will be discussed will answer the question "Does "Made in Croatia" written on fashion products influence consumers intention to buy a certain fashion product?".

## LITERATURE:

1. Aichner, T. (2013) *Country-of-origin marketing: A list of typical strategies with examples*. Journal of Brand Management, 21(1), 81–93.
2. Aiello, G. et al. (2009) *An international perspective on luxury brand and country-of-origin effect*. Journal of Brand Management, 16(5-6), 323-337.
3. Amine, L. S. and Shin, S.-H. (2002) *A Comparison of Consumer Nationality as a Determinant of COO Preferences*, Multinational Business Review, 10(1), 45-53.
4. Andéhn, M., Nordin, F., and Nilsson, M. E. (2015) *Facets of country image and brand equity: Revisiting the role of product categories in country-of-origin effect research*. Journal of Consumer Behaviour, 15(3), 225–238.
5. Arora, A. S., McIntyre, J. R., Wu, J., and Arora, A. (2015) *Consumer response to diffusion brands and luxury brands: The role of country of origin and country of manufacture*. Journal of International Consumer Marketing, 27(1), 3-26.
6. Balabanis, G. and Diamantopoulos, A. (2004) *Domestic Country Bias, Country- of-Origin Effects, and Consumer Ethnocentrism: A Multidimensional Unfolding Approach*, Journal of the Academy of Marketing Science. Volume 32(1), 80-95. [1]  
[SEP]
7. Cappelli, L. et al. (2017) *Are Consumers Willing to Pay More for a “Made in” Product? An Empirical Investigation on “Made in Italy”*. Sustainability, 9(4), 556.
8. Chan, W., Cheung, R. and Tse, A. (2007) *China: small budgets, small wardrobes*, McKinsey Quarterly, 4(4), 70-74.
9. Cheah, I., Zainol, Z. and Phau, I. (2016) *Conceptualizing country-of-ingredient authenticity of luxury brands*, Journal of Business Research, 69, 5819-5826.
10. Chen, H. (2009) *Effects of country variables on young generation’s attitude towards American products: a multi-attribute perspective*, Journal of Consumer Marketing, 26 (3), 143-154.
11. Esmaeilpour, F., & Abdolvand, M. A. (2016) *The impact of country-of-origin image on brand loyalty: evidence from Iran*, Asia Pacific Journal of Marketing and Logistics, 28(4), 709-723.
12. Gerke, A., Chanavat, N., & Benson-Rea, M. (2014) *How can Country-of-Origin image be leveraged to create global sporting goods brands?*, Sport Management Review, 17(2), 174-189.
13. Godey, B., Pederzoli, D., Aiello, G., Donvito, R., Chan, P., Oh, H., Singh, R., Skorobogatykh, Irina I., Tsychiya, J. & Weitz, B. (2012) *Brand and country-of-origin effect on consumers' decision to purchase luxury products*, Journal of Business research, 65(10), 1461-1470.
14. Hui, M. K. and Zhou, L. (2003) *Country-of-Manufacture Effects for Known Brands*, European Journal of Marketing, 37(1/2), 133-153.
15. Jin, B., Park, J.Y. and Ryu, J.S. (2010) *Comparison of Chinese and Indian consumers’ evaluative criteria when selecting denim jeans: a conjoint analysis*, Journal of Fashion Marketing and Management, 14 (1), 180-194.
16. Jung, H., Lee, Y., Kim, H., and Yang, H. (2014) *Impacts of country images on luxury fashion brand: facilitating with the brand resonance model*. Journal of Fashion Marketing and Management, 18(2), 187-205.
17. Jung, J. and Sung, E. (2008) *Consumer-based brand equity: comparisons among Americans and South Koreans in the USA and South Koreans in Korea*, Journal of Fashion Marketing and Management, 12 (1), 24-35.
18. Kim, N., Chun, E., and Ko, E. (2017) *Country of origin effects on brand image, brand evaluation, and purchase intention: A closer look at Seoul, New York, and Paris fashion collection*. International Marketing Review, 34(2), 254-271.

19. Kim, E. Y., Knight, D.K. and Pelton, L.E. (2009) *Modelling brand equity of a US apparel brand as perceived by generation Y consumers in the emerging Korean market*, Clothing and Textiles Research Journal, 27 (4), 247-258.
20. Lee, W. J., Phau, I., & Roy, R. (2013) *"Bonds" or "Calvin Klein" Down-under: Consumer ethnocentric and brand country origin effects towards men's underwear*. Journal of Fashion Marketing and Management, 17(1), 65-84.
21. Lim, K. and O'Cass, A. (2001) *Consumer Brand Classifications: An Assessment of Culture-of-Origin versus Country-of-Origin*, Journal of Product and Brand Management, 10 (2), 120-136.
22. Liu, S., Perry, P., Moore, C., & Warnaby, G. (2016) *The standardization-localization dilemma of brand communications for luxury fashion retailers' internationalization into China*, Journal of Business Research, 69(1), 357-364.
23. Mort, G. S. and Duncan, M. (2003) *"Own by...": Country of Origin's New Cue*, Journal of International Consumer Marketing, 15(3), 49- 69.
24. O'Cass, A. and Lim, K. (2002) *Understanding the younger Singaporean consumers' views of Western and Eastern brands*, Asia Pacific Journal of Marketing and Logistics, 14 (4), 54–79.
25. O'Cass, A., and Siahtiri, V. (2013) *In search of status through brands from Western and Asian origins: Examining the changing face of fashion clothing consumption in Chinese young adults*. Journal of Retailing and Consumer Services, 20(6), 505-515.
26. Parkvithee, N., & Miranda, M. J. (2012) *The interaction effect of country-of-origin, brand equity and purchase involvement on consumer purchase intentions of clothing labels*, Asia Pacific Journal of Marketing and Logistics, 24(1), 7-22.
27. Peterson, R.A. and Jolibert, A.J.P (1995) *A Meta-Analysis of Country-Of-Origin Effects*, Journal of International Business Studies, Vol. 26(4), 883-900.
28. Phau, I. (2010) *An Australian perspective of the effects of brand image and product quality on diffusion brands of designer jeans*. Journal of Global Business and Technology, 6(1), 41.
29. Phau, I. and Cheong, E. (2009) *How young adult consumers evaluate diffusion brands: effects of brand loyalty and status consumption*. Journal of International Consumer Marketing, 21(2), 109-123.
30. Phau, I. and Yip, S.L. (2008) *Attitudes toward domestic and foreign luxury brand apparel: a comparison between status and non-status seeking teenagers*, Journal of Fashion Marketing and Management, 12(1), 68-89.
31. Pucci, T., Casprini, E., Guercini, S., and Zanni, L. (2017) *One country, multiple country-related effects: An international comparative analysis among emerging countries on Italian fashion products*. Journal of Global Fashion Marketing, 8(2), 98-112.
32. Rashid, A., Barnes, L. and Warnaby, G. (2016) *Management perspectives on country of origin*, Journal of Fashion Marketing and Management, 20(2), 230-244.
33. Riza Apil, A., and Kaynak, E. (2010) *Georgian consumers' evaluation of products sourced from European Union member countries: Country of origin impact*. International Journal of Commerce and Management, 20(2), 167-187.
34. Sutter, M. B., Polo, E. F., and MacLennan, M. L. F. (2014) *Atributos da imagem do país de origem como fonte de vantagem competitiva: estudo no segmento internacional da moda brasileira*. Internext, 9(2), 75-93.
35. Tjandra, N. C., Omar, M., & Ensor, J. (2015) *Advanced and emerging economies Generation Y's perception towards country-of-origin*. International Journal of Emerging Markets, 10(4), 858-874.



## MARKETING INNOVATIONS IN POLISH SMALL AND MEDIUM ENTERPRISES

**Paula Pyplacz**

*Czestochowa University of Technology, Faculty of Management,  
Institute of Management Information Systems, Poland  
paula.pyplacz@wz.pcz.pl*

**Katarzyna Liczmanska – Kopcewicz**

*Nicolaus Copernicus University in Toruń, Department of Enterprise Management, Poland  
kliczmanska@umk.pl*

**Katarzyna Mizera**

*WSB University in Wroclaw, Faculty of Economics in Opole, Poland  
katarzyna.mizera@wsb.wroclaw.pl*

### ABSTRACT

*The growing role of the SME sector and the need to meet the requirements of competition from domestic and foreign companies indicate the need to implement innovations in the marketing sphere. These innovations are an important source of growth in the functioning and development of many small and medium-sized enterprises and the possibility of competing for large units. Marketing strategy is a kind of business philosophy that should be implemented at the stage of market, customer, product competition analysis. The marketing strategy is based on marketing innovations, which should be part of the current business activities. The article shows the significance and the form of marketing innovations in small and medium enterprises. The results of the research conducted in 2017 within the Enterprise Innovation Barometer were analysed. Focus is given to marketing innovation data. The work also shows the role of two solutions that can contribute to the implementation of marketing innovations and can be innovative at the same time.*

**Keywords:** *marketing innovations, marketing management, small and medium enterprises*

### 1. INTRODUCTION

In today's market environment, marketing, as a set of rules defining the overall philosophy of the company, is at the same time one of the organisational functions that is a field of specialised management. The essence of marketing defines the general principles of conduct that direct practical activity in this field without prejudging the shape of the marketing strategy adopted by the company under specific business conditions. In today's conditions innovation is a starting point for strategic actions (creation of marketing strategy). It should be noted that the main influence on marketing innovation has the customer, and more precisely the desire to meet his or her needs. Therefore the behaviour of buyers is an important determinant of the creation of marketing innovations. The customer, as the main asset of the company, must make a satisfactory purchase, and must also be satisfied with the entire process before and after the sale. The role and purpose of marketing change accordingly. Rather than manipulating customers, they seek genuine engagement, accurate information and creative service. This approach involves high costs of continuous monitoring and tracking of the market situation. However, in a highly competitive environment, both on local and global markets, it is less costly to make decisions based on specific data and information, rather than acting on an intuitive basis. The changes that have taken place in marketing relate to its role and its perception in organisation, the level of techniques adaptation, methods and processes of marketing shaping of the market and the penetration of many other disciplines.

In addition, the development of science and technology, particularly in the fields of computerisation of management processes, has led to the emergence of new methods using information technologies in marketing processes. The purpose of this paper is to present the role and forms of marketing innovations in small and medium enterprises. The significance of marketing innovations of this type was assessed on the base of research carried out in 2017 within the Barometer of Innovativeness in small and medium enterprises sector. The work also demonstrates the role of two solutions, Marketing Intelligence and CRM, which can contribute to the implementation of marketing innovations, but at the same time can be marketing innovations itself.

## **2. MARKETING INNOVATIONS**

Innovation is one of the basic instruments of the growth strategy ensuring a competitive advantage. The ability to generate innovation is becoming more important than ever, enabling companies to build and maintain a competitive advantage against the rapidly changing consumer preferences and shortened product lifecycles (Rubera, Kirca, 2012; Zastempowski, 2014). Innovation is widely regarded as a key success factor, both market practitioners and theoreticians believe that its introduction is becoming a necessary condition for development (Cho, Pucik, 2005, pp. 27-28, Rajapathirana, Hui, 2017). Growing customers' requirements (Kovács, Kot, 2016) induce companies to seek solutions that help achieve innovations with a high level of novelty (Mahmud, Aryanto, Hasyim, 2017, Rubera, Kirca, 2012, Liczmańska-Kopcewicz, 2018). The ability to anticipate consumer needs and respond faster than competitors should generate significant benefits for innovation-oriented companies (Simpson, Siguaw, Enz, 2006). Marketing methods and tools play an important role in the evolution of industries (Bhaskaran, 2006; Chen, 2006). Innovation is recognised as a decisive factor in the creation of well-being, a fundamental process for the company's competitiveness and a key source of long-term success in an ever-changing environment (Medrano, Olarte-Pascual, 2015; Crissan, Apaydin, 2010, pp. 444; Zastempowski, 2014, pp. 27-28). According to the Oslo methodology (OECD, 2005) four types of innovations are distinguished: product, process, organisational and marketing. These four groups of innovations are further divided into technological and non-technological ones. Technological innovations include product and process innovations, and non-technological ones include marketing and organisational (Liczmańska-Kopcewicz, 2018). This study focuses on non-technological marketing innovations. The areas of marketing innovations are: personal marketing, ambient marketing, environmental marketing, guerrilla marketing, ambush marketing, viral marketing, product placement, whisper marketing, neuromarketing, geomarketing, behavioral marketing and others (Ungerma et al., 2018, pp. 133). More enterprises actively identify and anticipate the needs of customers, and then respond appropriately to them, creating greater value for buyers (Ren et al. 2010, Pyplacz, Liczmańska-Kopcewicz, 2018). Modern, innovative marketing has a beneficial effect on increasing sales and reducing costs, which improves competitiveness (Kamp, Parry, 2017). Marketing innovations are gaining importance both for the company itself and for customers. Marketing innovations have a positive impact on productivity (Sivadas, Dwyer, 2000, Zhou, Yim, Tse, 2000) the company's financial results (Aksoy, 2017) and the ability to improve, strengthen and maintain the competitive advantage of the company (Ozkaya et al., 2015; Naido, 2010). The concept of innovation is understood differently by scientists from various fields of business and management. Economists perceive marketing innovations from a product and process perspective, and marketing researchers conceptualise innovations from the point of view of commercialisation (Cohen and Levinthal, 1989, Sood, Tellis, 2009, Gupta et al., 2016). The idea of marketing innovations combines theories of marketing, distribution and sales (Jones et al., 2013). In the subject literature, categorisations of marketing innovations can be distinguished based on the market approach (Luo, Tung, 2007), communication channel (Guerrieri and Meliciani, 2005; Trunfio et al., 2006), product or service

distribution (Singh et al. 2008; Kask, 2011). Despite the departure from traditional marketing-mix also in the definition of marketing innovation, we can distinguish four elements that determine the origin of innovation. Internal factors contributing to marketing innovation are, first of all, the desire to strengthen market position and maintain or increase profitability of the business (consisting of a vision and material, financial, intangible and technological assets) (Łobos, Szewczyk, 2014). Marketing innovation is a broad, interdisciplinary concept, and management, marketing methods and tools and ICT are of particular importance. Product as the first element of marketing mix is subject to constant changes and modifications. However, innovations less and less apply to so called core product or service. In terms of innovation, changes are usually made in real or extended product. These are any changes in form, payment method, appearance, packaging, new image, product transfer, etc. The next element of marketing mix - price - is also the area of search for innovation. We increasingly see "treatments" on the border of economics, psychology, which are to convince the consumer of the price. These are all types of discounts, promotions, loyalty programs, etc. Another determinant of marketing innovation are distribution methods, including the introduction of new sales channels. Innovations are visible in the so-called crossing industry boundaries, intermingling of different types of business and the overlapping roles of the manufacturer and the intermediary. Rapidly evolving area of marketing innovation is promotion. Companies are in the process of applying new forms of market communication and information tools to reach the chosen (narrow or broad) group of recipients. Actions from broadly understood promotion-mix, in terms of: personal promotion, advertising, promotion and PR are implemented. This group of innovations includes, for example, the introduction of new forms of advertising (such as: ambient media, product placement, advergames, social media marketing, shopper marketing), new types of personal sales (i.e. CLM in the pharmaceutical market) or non-standard forms of marketing communication (i.e. event marketing, crowdsourcing marketing, whisper or guerilla marketing, etc.). Another important determinant which connects with all previously mentioned elements of marketing mix are information-communication technologies (ICT). These technologies are sometimes considered as a separate group of innovations. ICT influences the introduction of new solutions for the sale of products, packaging as well as changes in marketing communication.

### **3. ICT AS AN IMPORTANT ELEMENT OF MARKETING INNOVATIONS**

According to A. Pomykalski "the concept of technological innovation includes new products and processes as well as significant technological changes in products and processes" (Pomykalski, 2001). These are changes that meet new or existing (known) customer needs in a new (more competent) way. Technological innovations such as: process, product or system, influence the company's competitiveness by directly influencing the needs of customers and by shaping the costs and the profitability of the company. Other types of innovations (innovation in management systems, environmental innovations, social innovations) impact the company's performance indirectly influencing the cost of new products and technologies (PARP, 2005). Despite their different influences and roles they are interrelated and difficult to implement separately. Innovative solutions that are novel are difficult to classify or describe. The study wanted to emphasize the role of two solutions, tools that show how ICT can contribute to the implementation of marketing innovations and, at the same time, can be marketing innovations. The first solution is Marketing Intelligence, which assists the manager in all stages of the marketing decision-making process, from identifying and evaluating the problem, by selecting the right data and analysing it, by hinting the right approach when making the decision to build a model of possible solutions, and ending with the implementation of the chosen solution and evaluation of different ways of acting. MI is knowledge that allows you to better understand customer's needs, reduce costs and risk, and increase profits.

For a proper and comprehensive working of MI marketing research should be conducted and relevant data should be provided. MI must be fully integrated with the marketing concept and with associated marketing management. The marketing strategy that has been adopted in the company, its goals, vision and mission must work together with the MI tools. At the same time, MI in marketing-orientated companies supports all marketing processes, including researching the market and environment of the company (market intelligence), conducting the strategy of researching competitors (competitive intelligence), mastering the sales processes (sales intelligence) and long-term customer relationship management strategies based on their needs and preferences (customer intelligence). Second solution concerns CRM (Customer Relationship Management), which is perceived both as a philosophy of operation and an IT system supporting customer relationship management. CRM embraces both innovations. Provides a set of tools and procedures that are essential to managing customer relationships and can be a module of an integrated IT management system already used by companies. This means that each business area can be integrated and at the same time the costs of implementation and operation of an additional IT are lower (Pypłacz, Mizera, 2014). Advanced CRM systems fulfil many basic and specialised functions in business management, especially in customer service management. These solutions are developed and evaluate in different directions. For example, PRM (Partner Relationship Management) is a solution that focuses on synchronising and better coordinating relationships with partners by providing an optimal channel structure. Enterprise Relationship Management (ERM) solutions are where the sales functions are integrated with marketing and customer service. They are associated with the rapidly evolving e-business (e-business, e-commerce, e-marketing) and knowledge management technologies. PIM (Personal Information Management) is a program for managing various types of notes such as tasks, contacts or appointments (Łobos, Pypłacz, 2015).

#### 4. EVALUATION OF THE USE AND EFFECTS OF ORGANISATIONAL INNOVATION IN THE SME SECTOR

Marketing innovations, as previously mentioned, are part of an organisation's innovation strategy. Although it is difficult to treat them separately, work presents the results of the study of the "Enterprise Innovation Barometer". The results of the marketing sphere were analysed. The survey was conducted from 1 March to 30 October 2017 by means of an electronic questionnaire placed on the internet platform. 243 companies from different industries participated in the survey, operating on the Polish market.

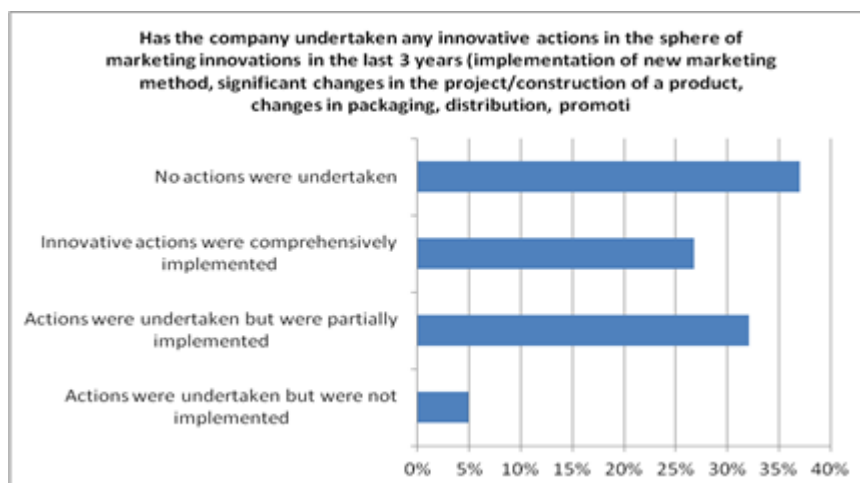

Figure 1: Answers to the question - Has the company undertaken any innovative actions in the sphere of innovative marketing in the last 3 years (own study based on research results)

Most of the surveyed companies (37%) did not undertake marketing innovation activities in 2014-2017. Only 27% of respondents comprehensively implemented marketing innovations. The other answers show some work, but not brought to an end. Lack of results, which should be the driving force for further innovations, may lead to discouragement of staff or resistance to further proposals. Marketing innovation usually involves all areas of the company and a large part of the crew, so it is important to take care of the "good climate" of change.

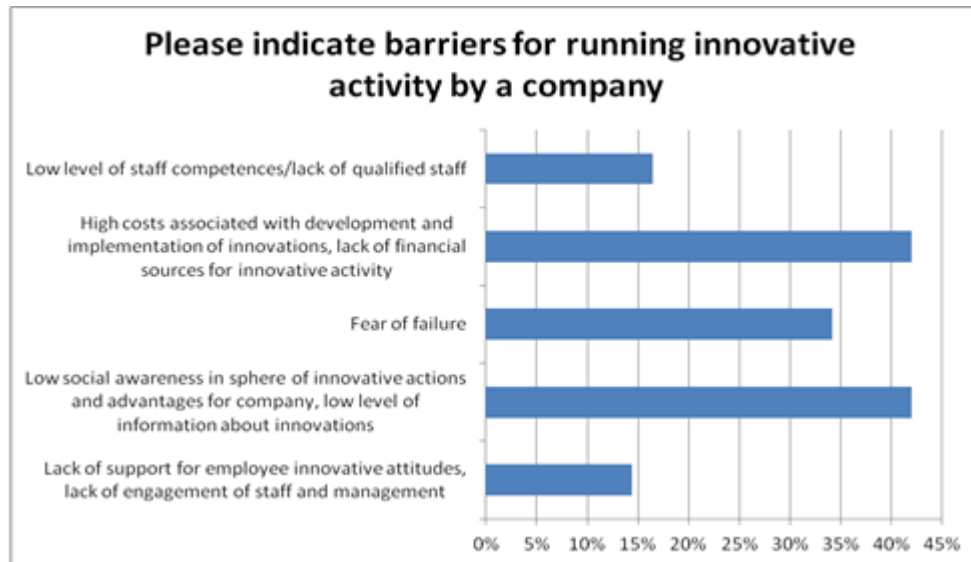

Figure 2: Barriers for running innovative activity by a company (own study based on research results)

Because a large percentage of the surveyed companies did not undertake any innovative marketing activities, respondents responded to barriers to innovation (Chart 2). Although this question was generally concerned with innovative activities, the answers obtained show that these barriers also apply to marketing innovations. Main barriers are: high costs associated with the development and implementation of innovation and therefore lack of sufficient funds (42% of responses) and low public awareness (42%). Since the SME sector has been surveyed, funding problems are a frequent occurrence and, unfortunately, largely inhibit the development of innovative activities. Owners of the surveyed companies connect the ability to invest in new solutions mainly with the full development of the company. But such strategy is wrong, at least for two reasons. First of all, the life cycle of innovation must be fluent, which means that work on this subject should be carried out on a regular basis, without downtime. Secondly, marketing innovations, in the present difficult market, are able to distinguish the company, show it and thus increase its effectiveness.

Figure following on the next page

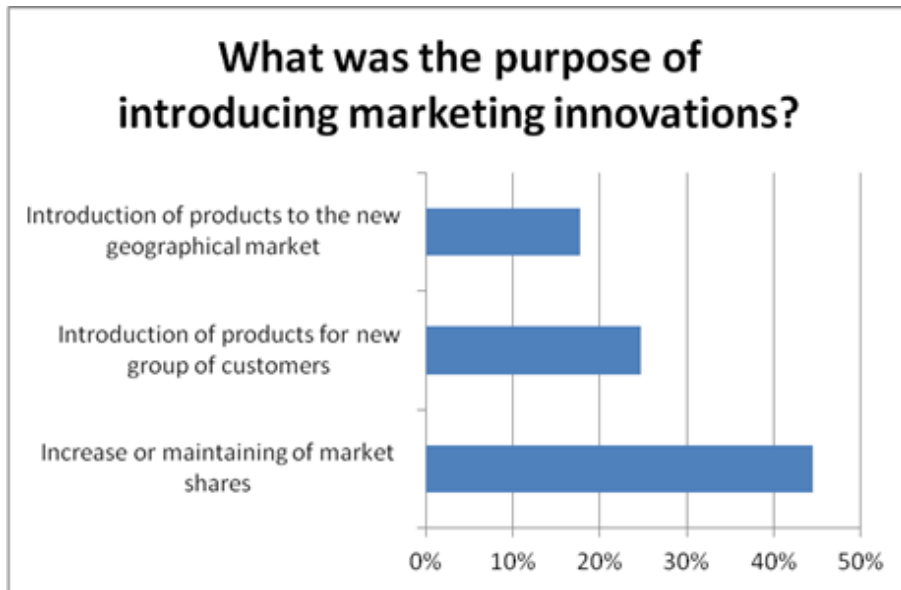

Figure 3: Purpose of introducing marketing innovations (own study based on research results)

However, as it can be seen from the research, some companies are working on marketing innovation. The main objective of these actions (Chart 3) is the willingness and the need to increase or even maintain the current market share (44% of responses). The second goal is to introduce the existing product to the new customer group (25% of the respondents) and introduce the product to the new market (18% of responses). Satisfactory is the fact that the purpose of implementing marketing innovations is known to respondents and is consistent with the assumptions of innovation implementation.

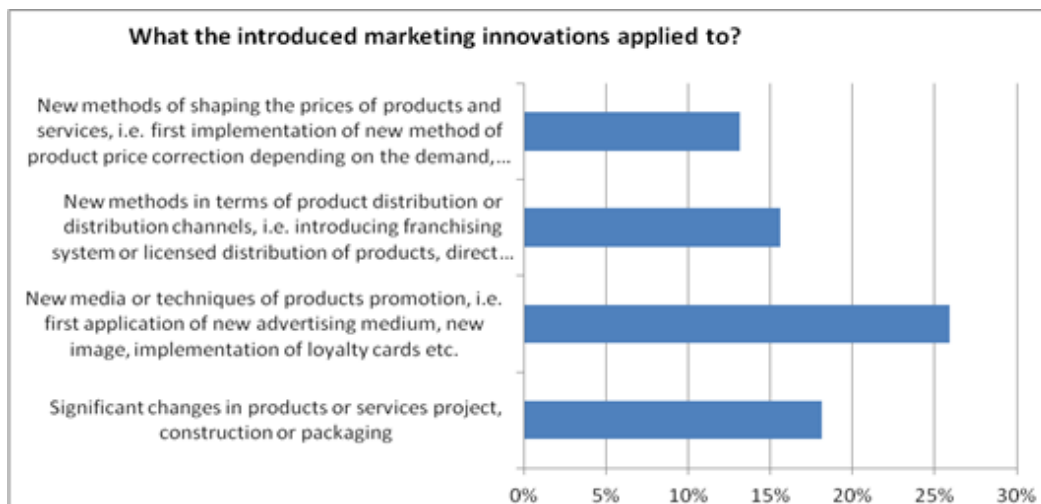

Figure 4: Answers to the question – What the introduced marketing innovations applied to? (own study based on research results)

In companies where marketing innovations were implemented, in majority (26% of responses) they applied to promotion activities i.e. the introduction of new advertising medium or the creation of a new product image. Subsequently, respondents considered changes in product packaging or services (18% of responses), new distribution methods or sales channels (16% responses), and new pricing methods (13% responses). This demonstrates a full, comprehensive approach to action in this area.

## 5. CONCLUSION

Marketing is an ever-evolving process of planning and implementing promotion concepts, price matching, advertising forms, behavioural research, changing customer needs and building new needs. Modern marketing supported by technological innovations, market research, new distribution channels is a key form of marketing support for any contemporary organization. The growing role of the SME sector and the need to meet the requirements of competition from domestic and foreign companies indicate the need to implement innovations in the marketing sphere. These innovations are an important source of growth in the functioning and development of many small and medium-sized enterprises and the possibility of competing for large units. Research conducted under the Enterprise Innovation Barometer indicates that although these innovations are rarely implemented companies see the need for such innovations. The task of modern companies is to keep pace with the constantly evolving market and the emerging needs of customers. These needs can be met and often triggered by new marketing efforts, such as the introduction of new methods for product distribution or sales channels, such as the introduction of a franchise system or product distribution license, direct sales, exclusive retail sales, new concept of product exposure. The second element of marketing mix - the promotion is also reflected in marketing innovations, among others, new media or promotion techniques of products, such as the first use of a new advertising medium, new image, introduction of loyalty cards, etc. Noteworthy for customers are changes to the new method of product price adjustment depending on market demand or the discount scheme, as well as changes in the design, construction or packaging of the goods or services. Thus, marketing innovations fit in with all the elements of mix marketing. Research indicates that although marketing innovations are rarely implemented companies see the need for such innovations. The task of modern companies is to keep pace with the constantly evolving market and the emerging needs of customers. These needs can be met and often triggered by new marketing efforts. Polish SME businesses offer relatively inexpensive workforce and can easily fulfill market niche rather than provide product quality and innovation. Companies existing in such a dynamic and technically advanced environment must incorporate offensive innovation in order to avoid being perceived as defensive innovators or imitators.

## LITERATURE:

1. Aksoy, H. (2017). How do innovation culture, marketing innovation and product innovation affect the market performance of small and medium-sized enterprises (SMEs)? *Technology in Society* No 51, (pp. 133-141).
2. Altkorn, J. (2000). *Podstawy marketingu*. Kraków: Instytut Marketingu.
3. Bhaskaran, S. (2006). Incremental innovation and business performance. Small and medium-size food enterprises in a concentrated industry environment, *Journal of Small Business Management*, Vol. 44, No 1 (pp. 64-80).
4. Chen, Y. (2006). Marketing innovation, *Journal of Economics and Management Strategy*, Vol. 15, No 1 (pp. 101-123).
5. Cho, H.J., Pucik, V. (2005). Relationship between innovativeness, quality, growth, profitability, and market value. *Strategic Management Journal*, No 26 (pp. 555-575).
6. Cohen, W. M., Levinthal, D. A. (1989). Innovation and learning: The two faces of R&D. *The Economic Journal*, Vol. 99, No 397 (pp. 569 – 596).
7. Crossan, M.M., Apaydin, M. (2010). A multi-dimensional framework of organizational innovation: A systematic review of the literature, *Journal of Management Studies*, Vol 47, No 6 (pp. 1154-1191).
8. Guerrieri, P., Meliciani, V. (2005). Technology and international competitiveness: The interdependence between manufacturing and producer services. *Structural Change and Economic Dynamics*, Vol. 16, No 4, (pp. 489–502).

9. Gupta, S., Malhotra, N.K., Czinkota, M., Foroudi, P. (2016). Marketing innovation: A consequence of competitiveness. *Journal of Business Research*, Vol. 69, (pp. 5671-5681).
10. *Jak wdrażać innowacje technologiczne w firmie*. (2005). Warszawa: Poradnik dla przedsiębiorców, Polska Agencja Rozwoju Przedsiębiorczości.
11. Jones, R., Suoranta, M., Rowley, J. (2013). Strategic network marketing in technology SMEs. *Journal of Marketing Management*, Vol. 29, No 5– 6, (pp. 671 – 697).
12. Kamp. B., Parry. G. (2017). Servitization and advanced business services as levers for competitiveness, *Industrial Marketing Management*, Vol. 60 (pp. 11-16).
13. Kask, T. (2011). Strategic decisions as drivers of innovation: The case of micro link. *Baltic Journal of Management*, Vol. 6 (3), (pp. 300 –319).
14. Kotler, Ph. (2005). *Marketing*. Poznań: Dom Wydawniczy Rebis.
15. Kovács, G., Kot, S. (2016). New logistics and production trends as the effect of global economy changes, *Polish Journal of Management Studies*, 14(2) (pp. 115-126).
16. Liczmańska-Kopcewicz, K. (2018). Redefining the role of the consumer in the process of creating marketing innovations. *Economic and social development: 33rd International Scientific Conference on Economic and Social Development "Managerial issues in modern business"* (pp. 561-570).
17. Luo, Y., Tung, R. L. (2007). International expansion of emerging market enterprises: A springboard perspective. *Journal of International Business Studies*, Vol. 38, No 4, (pp. 481– 498).
18. Łobos, K., Pyplacz, P. (2015). *Funkcje i narzędzia zarządzania dla małych i średnich przedsiębiorstw*. Warszawa Wyd. CeDeWu, p. 62
19. Łobos, K., Szewczyk, M. (2014). The Level and Determinants of Organizational and Marketing Innovativeness in Industrial Enterprises Functioning in the Polish Market on the Basis of Data for the Years 2010-2012, *Littera Scripta*, Nr 2, p. 21-33
20. Mahmud, M., Aryanto, V.D., Hasyim, H. (2017). The effect of innovation capability and new product development of marketing performance of batik SMEs, *Polish Journal of Management Studies*, 15(2) (pp. 132-142).
21. Medrano, N., Olarte-Pascual, C. (2015). An empirical approach to marketing innovation in small and medium retailers: an application to the Spanish sector, *Contemporary Economics*, Vol 10, No 3 (pp. 205-214).
22. Naidoo, V. (2010). Firm survival through crisis: the influence of market orientation, marketing innovation and business strategy, *Industrial Marketing Management*, No 39, (pp. 1311-1320).
23. OECD (2005), *Business Clusters: Promoting Enterprise in Central and Eastern Europe*, OECD Publishing.
24. Ozkaya E., Droge C., Hult M., Calantone R., Ozkaya E. (2015). Market orientation, knowledge competence, and innovation, *International Journal of Research in Marketing*, No 32, (pp. 309-318).
25. Pilarczyk, B. (2011). *Innowacje w komunikacji marketingowej*. Kraków: PTE, Zeszyty Naukowe nr 9.
26. Pomykański, A. (2001). *Zarządzanie innowacjami*. Warszawa: PWN.
27. Pyplacz, P., Liczmańska-Kopcewicz, K. (2018). Process innovation as a factor for the development of small enterprises in Poland. *Innovation management and education excellence through Vision 2020: proceedings of the 31st International Business Information Management Association Conference (IBIMA)* (pp. 3156-3165).



28. Pypłacz, P., Liczmańska-Kopcewicz, K. (2018). Relationship between pro-innovation organizational culture with realizing goals concerning product and marketing innovations in companies from FMCG sector. *Leadership, innovativeness and entrepreneurship in a sustainable economy: ICoM 2018: 8th International Conference on Management*, (pp. 511-515).
29. Pypłacz, P., Mizera, K. (2014). *CRM a zarządzanie relacjami z klientami w małej organizacji*. Wrocław: Zeszyty Naukowe Wyższej Szkoły Bankowej we Wrocławiu.
30. Rajapathirana, R.P.J., Hui, Y. (2017). Relationship between innovation capability, innovation type, and firm performance. *Journal of Innovation & Knowledge* (article in press).
31. Ren, L., Xie, G., Krabbendam, K. (2010). Sustainable competitive advantage and marketing innovation within firms, a pragmatic approach for Chinese firms, *Management Research Review*, 33 (1), (pp. 79– 89).
32. Rubera, G., Kirca, A.H. (2012). Firm innovativeness and its performance outcomes: A meta-analytic review and theoretical integration, *Journal of Marketing*, 73(3) (pp. 130-147).
33. Simpson, P.M., Siguaw, J A. and Enz, C A. (2006). Innovation orientation outcomes: The good and bad, *Journal of Business Research*, Vol 59 (pp. 1133-1141).
34. Singh, R. K., Garg, S. K., & Deshmukh, S. G. (2008). Strategy development by SMEs for competitiveness: A review. *Benchmarking: An International Journal*, Vol. 15, No 5, (pp. 525–547).
35. Sivadas, E., Dwyer, R. (2000). An examination of organizational factors influencing new product development in internal and alliance-based processes, *Journal of Marketing*, No 64, (pp. 31-40).
36. Sood, A., Tellis, G. J. (2009). Do innovations really pay off? Total stock market returns to innovation. *Marketing Science*, Vol. 28, No 3, (pp. 442 – 456).
37. Trunfio, M., Petruzzellis, L., Nigro, C. (2006). Tour operators and alternative tourism in Italy: Exploiting niche markets to increase international competitiveness. *International Journal of Contemporary Hospitality Management*, Vol. 18, No 5, (pp. 426– 438).
38. Ungerman, O., Dedkova, J., Gurinova, K. (2018). The impact of marketing innovation on the competitiveness of enterprises in the context of industry 4.0. *Journal of Competitiveness*, Vol. 10/2 (pp. 132-148).
39. Zastempowski, M. (2014). The innovative potential of Polish enterprises. *Acta Universitatis Nicolai Copernici Zarządzanie*, No 1 (pp. 27-37).
40. Zhou, K.Z., Yim, C.K., Tse, D.K. (2000). The effects of strategic orientations on technology – and market-based breakthrough innovations, *Journal of Marketing*, No 69 (pp. 42-60).

# FORECASTING CORRECTNESS OF INCURRING CREDIT WITH THE AID OF E.I. ALTMAN'S, J. GAJDKA'S AND D. STOS'S DISCRIMINANT ANALYSIS MODELS ON THE EXAMPLE OF 200 STUDIED COMPANIES FROM OPOLE AND POMORSKIE PROVINCES WITHIN 2010-2018

**Rafal Parvi**

*WSB University in Wroclaw, Faculty of Economics in Opole, Wroclaw, Poland  
rafalp4@o2.pl*

## **ABSTRACT**

*The credit risk related to issuing credit for a company is mostly the result of too high amount of the incurred credit, wrong prediction of future periods and repayment of the incurred liability. In order to minimize risk, as part of information about a credited company, there should be technical and economical information enabling to conduct "collective evaluation of the company's activity" with the use of E.I. Altman's, J. Gajdka's and D. Stos's models. Both models were used in the group of the studied companies of Opole and Pomorskie provinces. The research showed that incurred credit contributed to improvement of the financial liquidity in both groups. However, credits of greater worth led to the lessened increase of net profit and contributed to the small decrease of companies showing net loss. On the other hand, the group of companies, in which credits of lower worth were incurred, could decrease the number of companies suffering from net loss.*

**Keywords:** *company, financial liquidity, credit, discriminant analysis, net profit*

## **1. INTRODUCTION**

Using the J. Gajdka's and D. Stos's model in practice, it should be noted that the model proves to be perfect for Polish conditions because it reflects the realities of the Polish market, and demonstrates correctness of incurred credit of studied companies. The E.I. Altman's model was also used in research because the research results had to be compared in terms of a difference from the Polish market because this ratio was created for the American market and its needs. 200 micro, small and medium-sized companies were studied in the research, including 100 companies from the Opole province and 100 companies from the Pomorskie province. Such a big group of the studied companies was used to indicate correctness of the company's decision on incurring credit. The goal was to indicate that the company, which did not have the financial liquidity, or was operating on the border of its maintenance, could improve or regain the financial liquidity after incurring credit (Gabrusiewicz, 2014, pp. 245-261; Jaworski, 2001, pp. 638-641; pp. Nowak, 2014, pp. 185-194; Rutkowski, 2007, pp. 420-429). However, the amount of properly incurred credit and the period of its duration were additionally taken into account because they had significant influence on the company's financial liquidity. Used models also enabled to indicate that the incurred credit influenced development of the subject's running a business positively, and even contributed to improve its financial condition. Nevertheless, it had to be incurred in a proper amount and for a proper period.

## **2. J. GAJDKA'S, D. STOS'S AND E.I. ALTMAN'S DISCRIMINANT MODELS**

The J. Gajdka's and D. Stos's model reflects the best research results because it was developed in Poland, where Polish companies underwent discriminant analysis. The J. Gajdka's, D. Stos's and E.I. Altman's models are comparable, but were developed for different economic realities. When both models were compared, differences between them were indicated (Parvi, 2015, pp. 141-149; Zarzecki, 2003, pp. 173-181).

The E.I. Altman's model has been used for dozens of years. It may distort a picture and a result of the research because it was used as early as in the 1970s. The credit risk related to issuing credit for investments is mostly the result of the credited company's wrong prediction of its realization (Czekaj, 2008, pp. 10-17; Dowgiałło, 2002, pp. 122-124), and as it can also be noticed in the conducted research, the wrong credit amount, either too low, or too high, and the time period, for which it was incurred. The E.I. Altman's model enables to forecast the course of economic events happening in the company within subsequent two years of its operation. The "Z" value, calculated on the basis of 5 economic and financial ratios, is the basis of this model (Czerwiński, 1980, pp. 44-55; Rutkowski, 2007, pp. 420-429):

*Table 1: E.I. Altman's guidelines for the company's classification (Source: E.I. Altman).*

<b>The "Z" ratio's value</b>	<b>The chance of the company's bankruptcy</b>
$Z \leq 1.8$	Very high
$1.8 < Z < 3$	Indefinite, but significant
$Z \geq 3$	Low

$$Z = 1.2 x_1 + 1.4 x_2 + 3.3 x_3 + 0.6 x_4 + 0,999 x_5$$

where:

X1 - working capital / assets in total

X2 – net income / assets in total

X3 – EBIT / assets in total

X4 – net market value of the company/liabilities in total

X5 – trade (net sale) / assets in total

These ratios are statistical assessment of performance of not only the manufacturing company, but also other kinds of the company. If the result of "Z" value's calculations is below three, it means that credit ratings of the company's need to be examined and assessed thoroughly because the indefinite or low chance of the company's bankruptcy, or its ability to overcome such situation, should be expected. In calculations of the E.I. Altman's "Z" ratio, attention should be paid on the X<sub>5</sub> ratio's value, which is trade (net sale) to assets in total, if the denominator shows low value in relation to the numerator. It may mean that the company is underfunded. That is why values not exceeding three that is  $X_5 \leq 3$  are considered to be the proper level of this ratio because, otherwise, the general assessment may be distorted. By the use of the "Z" ratio, we can predict c. 80-90% of accurate forecasts of the companies' bankruptcy, or occurring problems with companies' maintenance of the financial liquidity. It concerns both one- and two-year periods. E.I. Altman, in his original model, took a sample consisting of 66 companies operating in the same period and sector of economy. Half of these companies was insolvent. At the beginning, he estimated values of 22 financial ratios. Later, the number of these ratios, after conducting statistical tests and verification of their meanings (values), was lessened to 5. These 5 ratios reflect economic and financial situation and predicted credit rating best. The cut-off point in the E.I. Altman's model amounts to 2.675. It is the discriminatory line separating the set of companies into two groups that is companies with high (below 2.675) and low likelihood of insolvency (above the cut-off point). According to E.I. Altman's research, the error of wrong companies' qualification to the set was then the smallest – as many as 94% of companies, which bankrupted in the previous year, reached the "Z" function's value below 2.675. In the same period, the studied value of 97% of solvent companies was above the cut-off point.

Correctness of the classification a year prior to bankruptcy amounted to 95%, and, by analogy, results of the whole sample amounted to 82% two years prior to insolvency. In Poland, D. Zarzecki undertook verification of discriminant analysis's models in 2003. The result of the analysis of these models conducted by D. Zarzecki shows that the J. Gajdek's and D. Stos's model brings the best research results (Parvi, 2015, pp. 141-149; Zarzecki, 2003, pp. 173-181):

$$Z = 0,7732059 - 0,0856425 \times X_1 + 0,0007747 \times X_2 + 0,9220985 \times X_3 + 0,6535995 \times X_4 - 0,594687 \times X_5$$

where:

- X1 – revenues from the sale/assets in total,
- X2 – (short-term liabilities/cost of production sold) x 360,
- X3 – net profit/assets in total,
- X4 – gross profit from the sale/net revenues,
- X5 – liabilities in total/assets in total.

In this model, the cut-off point is 0.45, which means that a studied company is not endangered with bankruptcy, if the above value is reached. This cut-off point is different from the one given by E.I. Altman, but it is related to the used ratios, which are different in particular models. A comparison of these two research methods by E.I. Altman, J. Gajdka and D. Stos leads to clear conclusions and gives an opportunity to consider both studied methods – the one developed and functioning in the world, and the one used in Polish companies and adjusted to the Polish market's conditions. The other method is a little bit more correlated with Polish companies. However, ratios show that both methods are close to each other, and comply in indicating these companies, which can be included either to the group of companies endangered with bankruptcy, or the one, in which there are successful companies able to compete on the market with incurring credit. Strengths of the discriminant analysis are:

- the system's easy functioning,
- the assessment's objectivity, in which measurable financial information is the basis,
- effectiveness measured with the forecasts' regularities scale,
- providing early warnings about credit risk.

Weaknesses are:

- effectiveness dependent on the quality of financial data set necessary to estimate values of particular ratios,
- only selected, not complex, quantitative information is taken into account in the model's construction,
- quantitative information is static.

During the study of companies with the use of both models, the method enabling to compare them in a way presenting their financial capabilities unambiguously was constructed. Depicted values of the "Z" ratios were present in conjunction with several variables presenting what differences occur at the chosen amount of contracted credit and its period (Antonowicz, 2013, pp. 11-20; Parvi, 2015, pp. 141-149). Used models are very useful in assessment of the companies' crediting and are often used in practice (Czerwiński, 1980, pp. 44-55). Nonetheless, conducted analyses are not attempts to estimate specific worth of credit and the period for which the company should go in debt, but the credit's maximum worth and period. It may lead to issuing credit to a company, which may not be able to repay it in future.

### 3. THE USE OF E.I. ALTMAN'S, J. GAJDKAS'S AND D. STOS'S DISCRIMINANT ANALYSIS MODELS IN ORDER TO INDICATE CORRECTNESS OF A DECISION ON INCURRING CREDIT ON THE EXAMPLE OF 200 STUDIED COMPANIES FROM OPOLE AND POMORSKIE PROVINCES WITHIN 2010-2018

In the Opole province, companies were studied with a comparison of the net profit in following years: a year prior to issuing credit, in the year of issuing credit and two years after issuing credit. The net income (division into following groups: from PLN 0 to PLN 100,000, from PLN 100,100 to PLN 200,000, from PLN 200,100 to PLN 500,000, and from PLN 501,000 to 1,000,000) and net loss were taken into account. The goal of such an analysis was to study range and opportunities of the obtained credit's amount in relation to the net profit and owned capital. The net profit, or net loss, indicated whether credit contributed to maintenance and improvement of the companies' financial liquidity, or it led to their bankruptcy. In 2010-2018, in the Opole province, companies of lower net profit (from PLN 0 to PLN 100,000 and from PLN 100,100 to PLN 200,000) were the most numerous – there were 80 such companies. In the Pomorskie province, ranges between PLN 0 and PLN 100,000, and between PLN 100,100 and PLN 200,000 were dominant – there were 55 such companies. It should be noted that the studied companies tended to maintain net profit.

*Table 2: Profit or loss of studied companies of the Opole province examined, 100 examined companies (Source: own development based on 100 studied companies of the Opole province)*

Year	Profit 0-100,000	Profit 100,100 – 200,000	Profit 200,100 – 500,000	Profit 500,100 – 1,000,000	Net loss
2010	28	33	15	4	20
2011	33	35	11	3	18
2012	35	37	10	3	15
2013	38	42	10	3	7
2014	37	41	12	5	5
2015	35	43	11	6	5
2016	36	44	11	5	4
2017	37	43	11	6	3
2018	37	44	10	6	3

*Table 3: Profit or loss of studied companies of the Pomorskie province examined, 100 examined companies (Source: own development based on 100 studied companies of the Pomorskie province)*

Year	Profit 0-100,000	Profit 100,100 – 200,000	Profit 200,100 – 500,000	Profit 500,100 – 1,000,000	Loss
2010	19	26	22	5	28
2011	17	26	24	6	27
2012	17	27	20	6	30
2013	17	30	21	6	26
2014	20	27	21	7	25
2015	24	30	20	6	20
2016	24	31	21	6	18
2017	24	31	22	6	17
2018	24	29	22	6	19

Moreover, incurring credit even led to decrease of the number of companies, in which the loss occurred – from 20 to 3 in the Opole province, and from 28 to 19 in the Pomorskie province. It proves that the decision on incurring credit, which contributed to improvement of the financial liquidity, was correct. These data were summarized in tables 2 and 3.

*Table 4: Average net profit in relation to value of long-term and current assets of studied companies of the Opole province in PLN thousands (Source: own development based on 100 studied companies of the Opole province)*

Year	Average Net profit	Average value of Long-term assets	Average value of Current assets	Average value of assets in total	Average value of the issued credit	Average Loss
Before issuing credit						
2010	199,875 (80 companies)	450,456	658,475	1,108,931	X	225,154 (20 companies)
The year of issuing credit						
2011	205,895 (82 companies)	552,326	798,459	1,350,785	251,425	289,478 (18 companies)
After issuing credit						
2012	245,425 (85 companies)	582,954	821,258	1,404,212	X	198,487 (15 companies)
2013	263,125 (93 companies)	623,745	836,547	1,460,292	X	125,158 (7 companies)
2014	266,254 (95 companies)	639,532	840,128	1,479,660	X	134,578 (5 companies)
2015	295,365 (95 companies)	644,588	855,655	1,500,243	X	132,472 (5 companies)
2016	301,431 (96 companies)	668,602	884,286	1,552,888	X	130,884 (4 companies)
2017	301,431 (97 companies)	695,632	880,025	1,575,657	X	133,295 (3 companies)
2018	301,431 (97 companies)	722,548	888,365	1,610,913	X	132,654 (3 companies)

In tables 4 and 5, the average net profit, average long-term and current assets, average worth of issued credit, and average loss of the companies that do not have the financial liquidity were presented. In the table 4, it should be noted that the average value of issued credit amounts to PLN 251,425. It is the working capital facility, revolving in subsequent years, and issued in 2011. The value of credit constitutes c. 1/3 of average values of current assets that is c. 33%. It is the evidence that credit, which is c. 30% of current assets, causes maintenance of the financial liquidity, and does not cause financial destabilization.

*Table 5: Average net profit in relation to value of long-term and current assets of studied companies of the Pomorskie province in PLN thousands (Source: own development based on 100 studied companies of the Pomorskie province)*

Year	Average Net profit	Average value of Long-term assets	Average value of Current assets	Average value of assets in total	Average value of the issued credit	Average Loss
Before issuing credit						
2010	223,114 (72 companies)	501,694	574,112	1,075,806	X	284,697 (28 companies)
The year of issuing credit						
2011	243,632 (73 companies)	509,332	589,362	1,098,694	428,951	294,563 (27 companies)
After issuing credit						
2012	257,896 (70 companies)	497,851	641,369	1,139,220	X	324,521 (30 companies)
2013	260,845 (74 companies)	515,687	658,562	1,174,249	X	336,459 (26 companies)
2014	263,451 (75 companies)	520,678	664,654	1,185,332	X	340,569 (25 companies)
2015	269,663 (80 companies)	526,772	676,512	1,203,284	X	342,754 (20 companies)
2016	285,981 (82 companies)	554,563	692,442	1,247,005	X	340,682 (18 companies)
2017	285,981 (83 companies)	565,942	712,697	1,278,639	X	344,562 (17 companies)
2018	285,981 (81 companies)	585,634	735,882	1,321,516	X	345,964 (19 companies)

While analysing the table 5, it should be noted that the average value of issued credit amounts to PLN 428,951. It is the working capital facility, revolving in subsequent years, and issued in 2011 as well. However, in case of companies of the Pomorskie province, its worth in relation to current assets is c. 7/10, so it is 69% of the credit's worth in relation to current assets. In this case, it can be seen clearly that companies maintain the financial liquidity harder with such debts. Moreover, the group of companies suffering loss reduced only from 28 to 27 in the year of incurring credit. As late as in 2012-2016, the group decreased to 18 companies. But in the Opole province, the number of companies suffering loss decreased four times – from 20 to 4 with 30% relation of incurred credit to current assets, while in the Pomorskie province, the number of such companies decreased from 28 to 18 with c. 68% relation of incurred credit to current assets. In conclusion, too heavy burden with debt and relying on foreign capital (over 68% of the current assets' value) leads to disturbance of the company's financial liquidity because the company is not able to pay such debt and use obtained funds properly and sensibly. Only these companies where foreign capital is 30% of current assets will use them sensibly and in accordance with their financial opportunities. The credit risk taken by a bank due to granting funds was minimal in case of companies with less credit. It is demonstrated by another calculations and use of E.I. Altman's, J. Gajdka's and D. Stos's methods. Nevertheless, granting funds constituting c. 50% of the company's current assets was too dangerous both for the bank and the company. Analysing course of economical events since the moment preceding issuing credit (Pomykalska, 2007, pp. 178-189) and subsequent years of the activity's duration, five selected ratios corresponding to particular models were used. The cut-off points for two chosen discriminant analysis models were obtained.

*Table 6: The use of E.I. Altman's, J. Gajdka's and D. Stos's discriminant analysis models on the example of 100 studied companies from the Opole province (Source: Own development on the basis of data of 100 selected companies from the Opole province)*

<b>E.I. Altman's model</b>	<b>2010</b>	<b>2011</b>	<b>2012</b>	<b>2013</b>	<b>2014</b>
The number of companies showing profit	80	82	85	93	95
The average "Z" ratio for companies	<b>3.12</b>	<b>3.45</b>	<b>3.32</b>	<b>4.11</b>	<b>4.15</b>
Absence of risk, values close to and above 3.0	low	absence	absence	absence	absence
The number of companies showing loss	20	18	15	7	5
The average "Z" ratio for companies	<b>1.98</b>	<b>2.36</b>	<b>1.95</b>	<b>1.72</b>	<b>1.80</b>
Absence of risk, values close to and above 3.0	<b>high</b>	<b>medium</b>	<b>high</b>	<b>high</b>	<b>high</b>
<b>The J. Gajdka and D. Stos's model</b>	<b>2010</b>	<b>2011</b>	<b>2012</b>	<b>2013</b>	<b>2014</b>
The number of companies showing profit	80	82	85	93	95
The average "Z" ratio for companies	<b>0.79</b>	<b>0.93</b>	<b>0.88</b>	<b>1.02</b>	<b>1.05</b>
Absence of risk, values close to and above 0.45	absence	absence	absence	absence	absence
The number of companies showing loss	20	18	15	7	5
The average "Z" ratio for companies	<b>0.31</b>	<b>0.39</b>	<b>0.37</b>	<b>0.34</b>	<b>0.33</b>
Absence of risk, values close to and above 0.45	<b>high</b>	<b>medium</b>	<b>high</b>	<b>high</b>	<b>high</b>

*Table 7: The use of E.I. Altman's, J. Gajdka's and D. Stos's discriminant analysis models on the example of 100 studied companies from the Opole province (Source: Own development on the basis of data of 100 selected companies from the Opole province)*

<b>E.I. Altman's model</b>	<b>2015</b>	<b>2016</b>	<b>2017</b>	<b>2018</b>
The number of companies showing profit	95	96	97	97
The average "Z" ratio for companies	<b>4.17</b>	<b>4.20</b>	<b>4.21</b>	<b>4.25</b>
Absence of risk, values close to and above 3.0	absence	absence	absence	absence
The number of companies showing loss	5	4	3	3
The average "Z" ratio for companies	<b>1.83</b>	<b>1.95</b>	<b>1.96</b>	<b>1.97</b>
Absence of risk, values close to and above 3.0	<b>high</b>	<b>high</b>	<b>high</b>	<b>high</b>
<b>The J. Gajdka and D. Stos's model</b>	<b>2015</b>	<b>2016</b>	<b>2017</b>	<b>2018</b>
The number of companies showing profit	95	96	97	97
The average "Z" ratio for companies	<b>1.06</b>	<b>1.12</b>	<b>1.13</b>	<b>1.15</b>
Absence of risk, values close to and above 0.45	absence	absence	absence	absence
The number of companies showing loss	5	4	3	3
The average "Z" ratio for companies	<b>0.35</b>	<b>0.38</b>	<b>0.39</b>	<b>0.39</b>
Absence of risk, values close to and above 0.45	<b>high</b>	<b>high</b>	<b>high</b>	<b>high</b>

*Table 8: The use of E.I. Altman's, J. Gajdka's and D. Stos's discriminant analysis models on the example of 100 studied companies from the Pomorskie province (Source: Own development on the basis of data of 100 selected companies from the Pomorskie province)*

<b>E.I. Altman's model</b>	<b>2010</b>	<b>2011</b>	<b>2012</b>	<b>2013</b>	<b>2014</b>
The number of companies showing profit	72	73	70	74	75
The average "Z" ratio for companies	<b>2.85</b>	<b>2.99</b>	<b>3.01</b>	<b>3.05</b>	<b>3.09</b>
Absence of risk, values close to and above 3.0	absence	absence	absence	absence	absence
The number of companies showing loss	28	27	30	26	25
The average "Z" ratio for companies	<b>0.88</b>	<b>0.89</b>	<b>0.97</b>	<b>1.03</b>	<b>1.07</b>
Absence of risk, values close to and above 3.0	<b>high</b>	<b>high</b>	<b>high</b>	<b>high</b>	<b>high</b>
<b>The J. Gajdka's and D. Stos's model</b>	<b>2010</b>	<b>2011</b>	<b>2012</b>	<b>2013</b>	<b>2014</b>
The number of companies showing profit	72	73	70	74	75
The average "Z" ratio for companies	<b>0.55</b>	<b>0.57</b>	<b>0.60</b>	<b>0.63</b>	<b>0.68</b>
Absence of risk, values close to and above 0.45	absence	absence	absence	absence	absence
The number of companies showing loss	28	27	30	26	25
The average "Z" ratio for companies	<b>0.35</b>	<b>0.36</b>	<b>0.38</b>	<b>0.40</b>	<b>0.42</b>
Absence of risk, values close to and above 0.45	<b>high</b>	<b>high</b>	<b>high</b>	<b>medium</b>	<b>medium</b>

*Table following on the next page*



*Table 9: The use of E.I. Altman's, J. Gajdka's and D. Stos's discriminant analysis models on the example of 100 studied companies from the Pomorskie province (Source: Own development on the basis of data of 100 selected companies from the Pomorskie province)*

<b>E.I. Altman's model</b>	<b>2015</b>	<b>2016</b>	<b>2017</b>	<b>2018</b>
The number of companies showing profit	80	82	83	81
The average "Z" ratio for companies	<b>3.10</b>	<b>3.11</b>	<b>3.12</b>	<b>3.11</b>
Absence of risk, values close to and above 3.0	absence	absence	absence	absence
The number of companies showing loss	20	18	17	19
The average "Z" ratio for companies	<b>1.09</b>	<b>1.13</b>	<b>1.15</b>	<b>1.14</b>
Absence of risk, values close to and above 3.0	<b>high</b>	<b>high</b>	<b>high</b>	<b>high</b>
<b>The J. Gajdka's and D. Stos's model</b>	<b>2015</b>	<b>2016</b>	<b>2017</b>	<b>2018</b>
The number of companies showing profit	80	82	83	81
The average "Z" ratio for companies	<b>0.72</b>	<b>0.74</b>	<b>0.77</b>	<b>0.75</b>
Absence of risk, values close to and above 0.45	absence	absence	absence	absence
The number of companies showing loss	20	18	17	19
The average "Z" ratio for companies	<b>0.40</b>	<b>0.42</b>	<b>0.40</b>	<b>0.38</b>
Absence of risk, values close to and above 0.45	<b>medium</b>	<b>medium</b>	<b>medium</b>	<b>medium</b>

On the example of the studied companies of the Opole province, the Altman's model shows significant improvement of the ratio in 2011 (3.45), when companies incurred credit, in relation to 2010 (3.12). Improvement of the selected companies' financial condition proves the above. In subsequent years, this value is the same, and in 2018, increases to 4.25. The J. Gajdka's and D. Stos's model also indicates values above the cut-off point from 0.79 to 1.15 in 2010-2018. Only in companies suffering from loss the cut-off's ratio tends to deteriorate with the use of both methods, which proves that even properly selected credit does not improve the companies' financial liquidity. The values described above present research included in the table 6-7. In turn, in the table 8-9, E.I. Altman's, J. Gajdka's and D. Stos's models were also used during research of companies of the Pomorskie province. The above research shows that companies, which maintained the financial liquidity with incurring credit, improved their financial condition, but their cut-off point's ratio are different from ones noted in the Opole province. In the E.I. Altman's model, improvement can be seen in 2010-2018 – ratio's value increased from 2.85 to 3.11. Whereas in the J. Gajdka's and D. Stos's model, the ratio's values increased from 0.55 to 0.75. It means that credit's worth constituting 69% of the current assets' worth is too heavy burden, and prevents from significant improvement of the financial liquidity. Moreover, it does not show the ratio similar to the one obtained in research in the Opole province.

*Figure following on the next page*

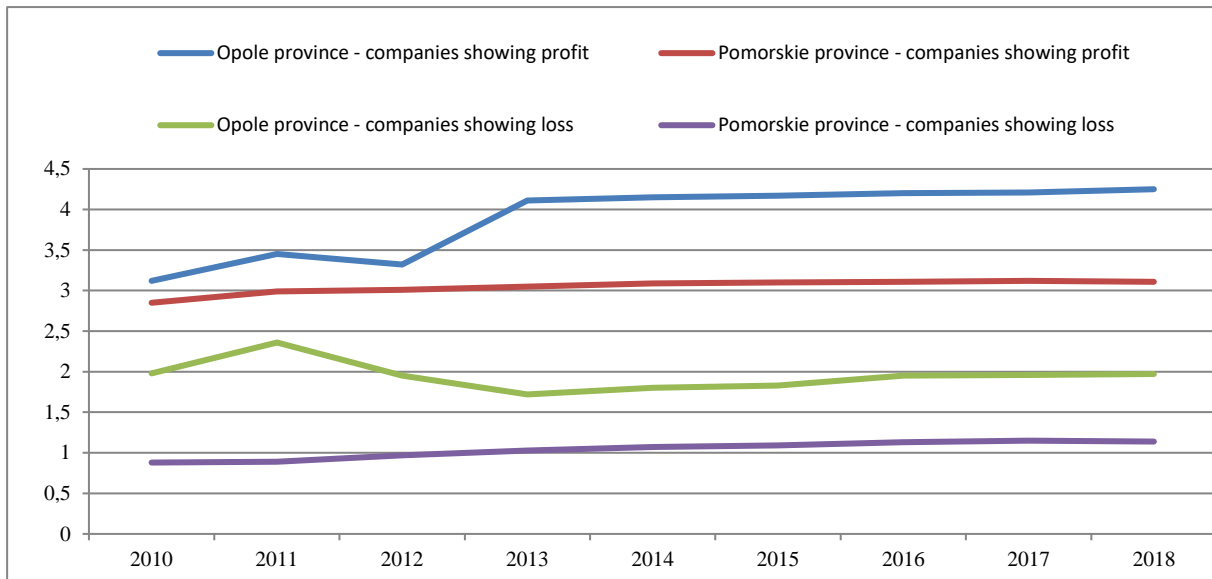

Figure 1: The use of E.I. Altman's model in the analysis of 200 companies of Opole and Pomorskie provinces showing profit and loss in 2010-2018 (Source: own development on the basis of data of selected companies from Opole and Pomorskie provinces).

Furthermore, the cut-off points' values of the companies showing net loss in the Pomorskie province do not show significant improvement of the financial liquidity, but they slightly vary in 2010-2018. In the E.I. Altman's method, they vary from 0.88 to 1.14, and in the J. Gajdka's and D. Stos's method – from 0.35 to 0.38. It evidences that greater worth of credit could not ensure companies satisfactory improvement of the financial liquidity, but worsened their situation.

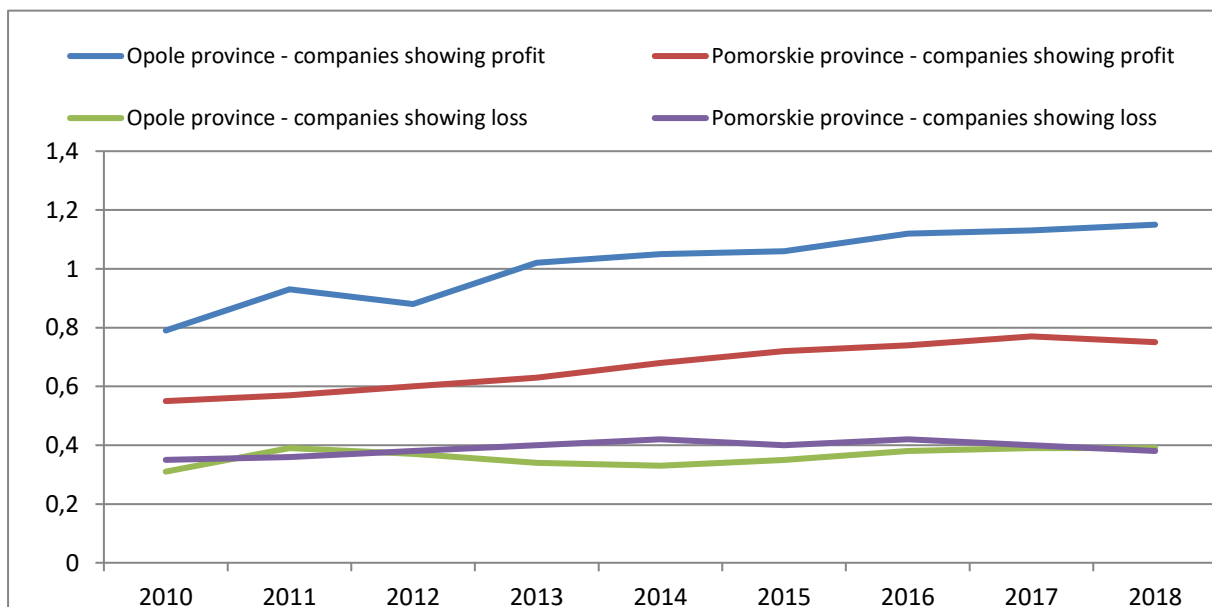

Figure 2: The use of the J. Gajdka's and D. Stos's model in the analysis of 200 companies of Opole and Pomorskie provinces showing profit and loss in 2010-2018 (Source: own development on the basis of data of selected companies from Opole and Pomorskie provinces).

Analysing net profit of the companies, it can be noted that issued credit influenced their development positively. There, its huge influence on the companies' net income can be seen.

Thanks to opportunity to incur credit, companies could develop dynamically and as they planned in their assumptions with credit constituting 30% of the current assets' worth. Only credit constituting 69% of the current assets' worth did not cause major changes in many companies and did not lead to improvement of the financial liquidity of the greater number of companies showing net loss. The sensibly selected credit resulted in the greater increase of net profit and contributed to the increase of net income and profit, without which the company could not develop and reach significant results.

#### 4. CONCLUSION

It should be emphasised that contracted credit in studied companies contributed to improvement of the financial liquidity. However, it was mostly in case of companies, whose credits were c. 30% of the current assets' worth. Furthermore, in case of companies of the Pomorskie province, whose credits were 69% of the current assets' worth, the financial liquidity was not improved as much as in case of lower credits incurred by the studied companies of the Opole province. Nevertheless, credits enabled companies to settle current liabilities, which is proven by lessened number of companies suffering from net loss because such a phenomenon occurred in the group of 100 studied companies in 2010-2018. Therefore, companies maintained good financial condition after issuing credit. It should be stated clearly that the decision on incurring credit was, indeed, correct. But it should be borne in mind that the amount of incurred credit must not exceed specific worth preventing from repaying incurred credit and settling liabilities, which could lead to the company's inability to debt service. That is why c. 30% of the company's current assets' value, resulting from research of the companies, is the optimal amount. The period, for which credit was incurred, is highly significant, but the studied companies contracted the working capital facility for one year with the possibility to renew it in subsequent years, which did not affect research and cause its distortion. The companies that had unevenly balanced liquidity or needed additional financial resources for the functioning on the market, and that took up a credit above the value exceeding 69% of the external funds in relation to their current assets, did not maintain the liquidity, and only 9 companies improved it in relation to 28 companies that were at risk of bankruptcy, which was reported in the Pomorskie Voivodeship. While the number of companies in Opole Voivodeship, which improved their liquidity, is 17, that is several times more than in Pomorskie Voivodeship, but the improvement occurred thanks to a taken credit, however the debt amounted only to 30% of the external funds in relation to their current assets. Therefore, there must be a firm answer that the credits that are incurred in the form of cash and account for more than 69% of the external funds in respect of current assets will not have a good impact on the financial condition of the studied companies, since such a capital obligation and interest liability constitutes a major burden for the company, which must within next months, after a credit was incurred, pay it back to the bank.

#### LITERATURE:

1. Antonowicz P. (2013). „*Własności wskaźnika rentowności sprzedaży brutto oraz produktywności majątku w prognozowaniu i ocenie zagrożenia upadłością przedsiębiorstw*”, w: "Czas na pieniądź. Zarządzanie Finansami. Mierzenie wyników przedsiębiorstw i ocena efektywności inwestycji", Zeszyty Naukowe Uniwersytetu Szczecińskiego nr 760, Finanse, Rynki Finansowe, Ubezpieczenia nr 59, pp. 11-20.
2. Czekaj J. (2008). „*Rynki, instrumenty i instytucje finansowe*”. Praca zbiorowa pod redakcją J. Czekaj, Warszawa, PWN, pp. 10-17.
3. Czerwiński S., Spiak J. Nietupski T. (1980). “*Calculation parametres de la regulation dans l'entreprises agricole*”. Nimes, CIOSTA, pp. 44 - 55.

4. Dowgiałło Z. (2002). „*Upadłość małych i średnich przedsiębiorstw w świetle badań*”, Szczecin, „Firma i rynek” Zachodniopomorska Szkoła Biznesu Szczecin nr 2/3, pp. 122 - 124.
5. Gabrusiewicz W. (2014). „*Analiza finansowa przedsiębiorstwa, teoria i zastosowanie*”, PWE, Warszawa, pp. 245-261
6. Jaworski, W. L. (2001). „*Bankowość*”. Praca zbiorowa pod redakcją W.L. Jaworskiego i Z. Zawadzkiej, Warszawa, Poltext, pp. 638-641.
7. Nowak E. (2014). „*Analiza sprawozdań finansowych*”, PWE, Warszawa, pp. 185-194.
8. Parvi R., (2015) „*Forecasting correctness of incurring credit with the aid of E.I. Altman's, J. Gajdka's and D. Stos's discriminant analysis models on the example of 200 studied companies from Opole and Podkarpackie provinces*”, Czech Technical University in Prague, pp. 141-149.
9. Pomykalska B., Pomykalski P. (2007). „*Analiza finansowa przedsiębiorstwa*”, Warszawa, PWN, pp. 178-189.
10. Rutkowski A. (2007) „*Zarządzanie finansami*”, PWE, Warszawa, pp. 420-429.
11. Zarzecki D. (2003). „*Analiza dyskryminacyjna jako metoda oceny zagrożenia bankructwem*”. W: Zarządzanie finansami. Mierzenie wyników i wycena przedsiębiorstw. Szczecin, Uniwersytet Szczeciński, pp. 173-181.

## **BUSINESS INTELLIGENCE SYSTEM FOR MANAGING NATURAL GAS CONSUMPTION OF PUBLIC BUILDINGS**

**Zlatko Tonkovic**

*University of Josip Juraj Strossmayer in Osijek,  
Faculty of Mechanical Engineering Slavonski Brod,  
Trg Ivane Brlić Mažuranić 2, 35000 Slavonski Brod, Croatia  
zlatko.tonkovic@hep.hr*

**Sasa Mitrovic**

*University of Zagreb, Faculty of Organization and Informatics,  
Pavlinska 2, 42000 Varaždin, Croatia  
smitrovic@foi.hr*

**Marijana Zekic-Susac**

*University of Josip Juraj Strossmayer in Osijek, Faculty of Economics in Osijek,  
Trg Lj. Gaja 7, 31000 Osijek, Croatia  
marijana@efos.hr*

### **ABSTRACT**

*The objective of this paper is to develop an intelligent model for managing natural gas consumption of public buildings using machine learning methods. The model is able to identify key predictors of natural gas consumption and while incorporated into a business intelligence system could provide an effective decision support for managers in public sector. Several machine learning methods based on decision trees were tested and the best model is suggested. The outcomes of this paper are expected to assist decision makers in Croatia in reducing natural gas consumption in public sector which is very important for the objectives of policy processes: strategies of energy development and national plans of energy efficiency in Croatia. Such intelligent system can be a powerful tool in decreasing expenditures of public sector and improving its efficiency.*

**Keywords:** *intelligent model, machine learning methods, natural gas consumption, public buildings*

### **1. INTRODUCTION**

There is a general consensus in European Union on importance of energy efficiency which is emphasized in legislation by European Parliament and European Council. On 19 May 2010 European Parliament and Council amended directive 002/91/EC for a new directive 2010/31/EU on the energy performance of buildings. In directive 2010/31/EU the European Parliament and the Council of the European Union stated that buildings account for 40% of all energy consumption in the European Union with building sector constantly expanding which leads to further increase of buildings energy consumption. Stated reasons represented a need for reduction of energy consumption in the buildings sector. In the need of reduction and increasing energy efficiency European Council emphasized objective of reducing by 20 % the European Union's energy consumption by the year 2020 in their in the Commission Communication entitled "Action plan for energy efficiency: realizing the potential". That action plan identified the potential for cost-effective energy savings. In spite of action plan European Parliament and European Council emphasized energy demand management as an important tool for European Union security of energy supply and influence in energy market in medium and long term (Union, 2010). In accordance with directive 2010/31/EU and European Union Commission Energy Efficiency Directive, Croatia has passed the Energy Efficiency Legislative

Act (Government, 2014) and, also, implemented National Energy Efficiency Action Plan entitled “The fourth national energy efficiency action plan for the Republic of Croatia for the period 2017 - 2019”(Energy, 2017). For monitoring the public buildings sector there is an Agency for Legal Affairs and Real Estate Brokerage (APN) that through its web application (ISGE) collects public sector buildings energy and water consumption data in centralized database. However, the web application lacks intelligent models that could identify energy consumption key predictors and provide effective decision support for managers in public sector. This paper uses ISGE data for natural gas and will be focused on developing a tool with integrated intelligent model for managing natural gas consumption of public buildings using machine learning methods that will help decision makers in Croatia in reducing natural gas consumption in public sector which is in accordance with directive 2010/31/EU on the energy performance of buildings by European Parliament and European Council. Aforementioned intelligent model can be a powerful tool for cost-effective natural gas savings and increasing energy efficiency in the public buildings sector. The aim of this paper is on creating an intelligent system that predicts natural gas consumption of public buildings using machine learning methods based on decision trees: classification and regression trees (CART), conditional inference trees (CTREE), random forest (RF), and gradient boosted trees (GBT) on the public buildings data from ISGE application database. The aim is to find best suited decision tree method on the ISGE dataset of Croatia public buildings and can be important tool for managing natural gas consumption.

## 2. PREVIOUS RESEARCH

Predicting energy consumption and decreasing cost while improving energy efficiency is gaining universal attention among researches in order to maintain the global temperature rise and reducing overall greenhouse gas emissions and CO<sub>2</sub> levels. Bouabaz et al. establish models for forecasting energy consumption of natural gas for heating buildings using artificial neural network (ANN) where the average percentage error was 3.2% (Bouabaz, Mordjaoui, Bouleknafet, & Belghoul, 2015). Williams & Gomez developed models using linear regression (LR), regression trees (RT) and multivariate adaptive regression splines (MARS) methods for predicting monthly natural gas and electricity consumption using building attributes and climate data where RT outperformed other methods when predicting energy consumption for large groups of homes and MARS predicted better at the house hold level (Williams & Gomez, 2016). The 2 year dataset from United Kingdom’s Department for International Development (DFID) was used by Fagiani et al. for measuring the preformance of: support vector regression (SVR), extreme learning machine (ELM), genetic programming (GP), artificial neural networks (ANNs), echo state networks (ESNs), and deep belief networks (DBNs). Best results for natural gas forecasting are achieved with SVR (Fagiani, Squartini, Bonfigli, & Piazza, 2015). Integrated Decision Support Systems (DSS) that uses machine learning methods for predicting building natural gas consumption on state level was proposed by Kokkinos, Papageorgiou, Dafopoulos, and Adritsos (2017). Kontokosta and Tull (2017) used linear regression (OLS), random forest, and support vector regression (SVM) to predict electric energy and natural gas consumption of 1.1 million buildings in New York by using b using the physical and spatial building attributes, and their energy use. Aforementioned authors discovered that attached buildings have lower usage intensity of natural gas. Zekic-Susac (2017) provided an overview of prediction models and methods in modelling public buildings energy consumption and grouped them into: (1) individual statistical methods such as linear regression, time series analysis, probability density functions, or similar methods, (2) comparative usage of statistical methods and machine learning methods, and (3) simulation modelling. Mitrovic and Zekic-Susac (2017) provided a systematic review of algorithms used in prediction models and methods in this domain for developing more efficient intelligent models in public buildings

sector. Zekić-Sušac, Has, and Mitrović (2018) have tested decision tree methods in predicting electricity consumption, and found that this group of methods has a potential in revealing important relationships within the variables that influence electricity consumption. Based on the previous research, it can be concluded that, although some machine learning methods were used in this area, authors didn't use decision tree methods sufficiently in natural gas prediction. Therefore, this paper will put more focus on machine learning methods that are based on decision tree algorithms. Another advantage of this paper is in the scope of ISGE dataset, which includes a larger number of attributes comparing to datasets used in previous research.

### **3. METHODOLOGY**

#### **3.1. Dataset and data preprocessing**

Agency for Legal Trade and Real Estate Brokerage (APN) in Croatia has a web application with centralized database for collecting and monitoring energy, natural gas and water consumption in public buildings. The first stage of data pre-processing included removing buildings that did not use natural gas as energy resource, and removing records with missing data, the dataset used in this research consisted of 1039 public buildings that are state-owned or operated by a government and use natural gas as the main energy resource for heating. The input space consisted of 143 attributes describing the usage of a building, a building's energy coefficients, geo-spatial, construction and heating data. The next step in data pre-processing was exclusion of attributes that were irrelevant for natural gas consumption. Evaluating the substantial contribution of attributes for natural gas consumption, attribute reduction was conducted. The relevance of attributes for natural gas consumption was evaluated on the basis of heuristics of a human expert, and attribute reduction was conducted. The total of 119 attributes was removed from the dataset, thus leaving only 29 attributes as relevant. The attribute names are shown in Table 1. After variable reduction, the third step was to detect and remove outliers from the dataset, after which the final dataset used for modeling consisted of 939 cases.

*Table following on the next page*

*Table 5: Attributes describing public buildings*

Attribute group	Attribute label	Attribute description
Geo-spatial data	V71	County
Construction data	V7	Flat gross floor area of building
	V8	Total surface of the net floor area of the heated part of the building
	V9	Surface area of the heated building section A
	V10	Gross volume of the heated part of the building surface area A
	V11	Number of level parts
	V17	Building shape factor
	V51	Heat transfer coefficient of the constructs, the heated ceiling
	V52	Thickness of thermal insulation layer to a heated ceiling
	V84	Building category (1 = independent building, 2 = complex building, 3 = complex, 4 = part of the building)
Heating data	V19	Total number of heat exchangers - radiators
	V20	Total installed capacity of heat exchangers - radiators
	V24	Total installed capacity of other heat exchangers
	V25	Total installed heat capacity of heat exchangers
	V37	Annual required energy use for heating
	V80	PTV energy source 1 code (0 = missing data, 1 = sun, 2 = electric energy, 3 = extra light oil, 4 = heat energy, 5 = light oil, 6 = LPG gas, 7 = LUS II, 8 = natural gas, 9 = other, 10 = steam-water, 11 = wood)
	V81	PTV energy source 2 code (0 = missing data, 1 = sun, 2 = electric energy, 3 = extra light oil, 4 = heat energy, 5 = light oil, 6 = LPG gas, 7 = LUS II, 8 = natural gas, 9 = other, 10 = steam-water, 11 = wood)
	V82	PTV preparation code (0 = nothing, 1 = central, 2 = combined, 3 = individual)
Data on the use of the building	V3	Number of employees
	V4	Number of users
	V5	Number of operating days in a week
	V6	Number of operating days in a year
	V13	Number of operating hours in the working day
Building energy coefficients data	V35	Maximum permissible transmission heat loss coefficient per unit of surface area of heated building part
	V39	Heat transfer coefficient of building components (roof)
	V42	Thickness of building components (roof)
	V46	Thickness of building components (floor)
	V50	Thickness of building components (windows)
	V64	Thickness of thermal insulation of the door



In order to train and test decision trees, it was necessary to normalize data (due to a wide range of attribute values), and to divide the sample into the training and validation subsamples. The training subsample was used to estimate the decision tree and consisted of 657 randomly selected cases (70%), while the validation subsample was used to test the saved tree on the hold-out data and consisted of 282 randomly selected cases (30%). To assure the possibility of comparison, all four methods were trained on the same training set, and validated on the same validation set.

### 3.2. Decision tree methods

The four decision tree methods were used in R software: classification and regression trees (CART), random forest (RF), conditional inference trees (CTREE), and gradient boosted trees (GBT). Regression variant of classification and regression tree (CART) as described by Breiman et al. is used in this research, which produces a continuous number in the output instead of a class probability. It builds a binary tree as a set of nested logical if-then conditions by separating input predictor variables into two pieces at every node and repeat separating step until each partition in binary tree contains only one data point or defined rule for stopping is satisfied (Breiman, Friedman, Olshen, & Stone, 1984). The algorithm for growing a full tree is the Gini index defined by Apte and Weiss (Apté & Weiss, 1997). Parameters used for CART in this research were: Gini index,  $cp = 0.01$ ,  $minsplit = 20$ ,  $cp = 0.01$ ,  $maxcompete = 4$ ,  $maxsurrogate = 5$ ,  $usesurrogate = 2$ , no. of cross-validation = 10,  $maxdepth = 30$ . In our research, the prune of misclassification error was used as the stopping rule in the training phase, while the minimum number of cases in a node  $n$  was 5. Random Forests (RF) method was developed by Breiman (1999). This method generates a collection of tree-structured classifiers where each tree vote for the most popular tree class (Breiman, 1999). Random forest based on classification and regression tree (RF-CART) algorithm was used in this paper for data analysis. Complexity parameter  $cp=0.01$  with ANOVA was used to save computing time in pruning trees. In this scenario the overall R-squared must increase by  $cp$  value at each step. The maximum depth parameter of all nodes was set to 30. The conditional inference tree (CTREE) was proposed by Hothorn et al. as an unified framework for recursive tree partitioning with unbiased variable selection which does not use pruning (Hothorn, Hornik, & Zeileis, 2006). To determine the separation of variable selection as a split variable the smallest  $p$ -value is used. We have used the following parameters for CTREE in our research: 19 terminal nodes,  $teststat = c("quad", "max")$ ,  $testtype=c("Bonferroni", "MonteCarlo", "Univariate", "Teststatistic")$ ,  $mincriterion=0.95$ ,  $minsplit=20$ ,  $minbucket=7$ ,  $stump=FALSE$ ,  $nresample=9999$ ,  $maxsurrogate = 0$ ,  $mtry = 10$ ,  $savesplitstats = TRUE$ ,  $maxdepth = 0$ . Gradient boosted tree (GBT) ensembles trees based on boosting process. It starts from a single node and iteratively adds splits to the tree using computed formula for evaluating the split candidates (Chen & Guestrin, 2016):

$$\mathcal{L}_{split} = \frac{1}{2} \left[ \frac{(\sum_{i \in I_L} g_i)^2}{\sum_{i \in I_L} h_i + \lambda} + \frac{(\sum_{i \in I_R} g_i)^2}{\sum_{i \in I_R} h_i + \lambda} + \frac{(\sum_{i \in I} g_i)^2}{\sum_{i \in I} h_i + \lambda} \right] - \gamma \quad (1)$$

In aforementioned formula  $I_L$  and  $I_R$  are sets of the left and right nodes after split. In this paper scalable end-to-end tree gradient boosting system XGBoost was implemented (Chen & Guestrin, 2016). Package XGBoost in each round of 10 cross-validation steps resamples observations and columns with  $Lambda$  of 0.01 for splitting nodes was used in this research.

### 3.3. Evaluating the accuracy of models

Each decision tree method has produced a model for predicting natural gas consumption. For determining the final splitting in regression trees, the mean square error (MSE) was used. To compare the efficiency of decision tree methods a variation of the MAPE formula was used to

provide symmetry suggested by Tofallis (Tofallis, 2015). This formula is known as symmetric mean average percentage error (SMAPE) and Armstrong introduced it in 1978 (Armstrong, 1978). The formula was computed according to (Zekić-Sušac et al., 2018):

$$SMAPE = 100 \frac{1}{n} \sum_{i=1}^n \frac{|y_t - y_c|}{|y_t| + |y_c|} \quad (2)$$

where  $y_t$  is the actual and  $y_c$  the forecast value, and  $n$  is total number of cases in dataset.

#### 4. RESULTS

The problem of predicting natural gas consumption is tested by decision tree methods and the research results are presented in this section of the paper. The CART produced final tree shown in Figure 1, with 9 nodes and 7 splitting variables. It can be seen from Figure 1 that the first variable used for split was V8 (Total surface of the net floor area of the heated part of the building), followed by V25 (Total installed heat capacity of heat exchangers), V80 (PTV energy source 1 code), V11 (Number of level parts), V50 (Thickness of building components (windows)), V84 (Building category), and V35 (Maximum permissible transmission heat loss coefficient per unit of surface area of heated building part). The SMAPE of the CART decision tree model was 28.06%.

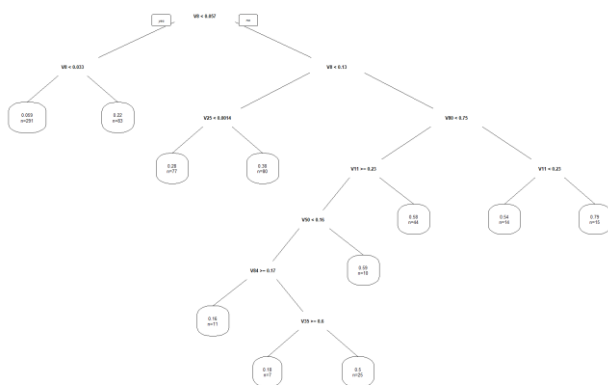

Figure 1: CART decision tree for predicting natural gas consumption

The random forest method has created an ensemble of maximum 500 trees, while the number of variables tried at each split was 8. Error conversion of random forest was relatively persistent after 300 generated trees. The accuracy of RF was lower than the accuracy of CART, since it has produced SMAPE of 52.18%. The CTREE decision tree model has produced a smaller number of splits with only 6 nodes and 3 selected predictors as important. The graphical presentation of CTREE is shown in Figure 3.

Figure following on the next page

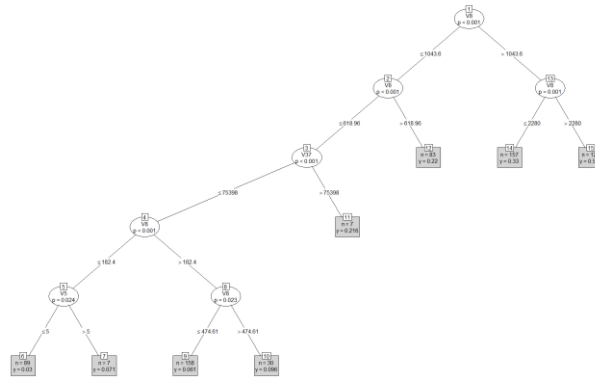

Figure 2: Conditional inference tree for predicting natural gas consumption

The accuracy of CTREE was significantly higher than the accuracy of RF, and slightly higher than CART since it has produced SMAPE of 26.79% which represented the most accurate model. The gradient boosted tree produced the SMAPE of 29.54% which is slightly lower in accuracy than CART and CTREE. In order to test if the difference among the accuracy of all four models is statistically significant, the t-test of difference in means was conducted for each pair of the models. The results of four decision tree methods are shown in Table 2.

Table 2: SMAPE error of the tested decision tree models

Decision tree method used for modeling	SMAPE (%)	No. of selected predictors	t-test of difference in means
CART	28.06	7	CART vs. RF: p=0.0000 CART vs. CTREE: p=0.5341 CART vs. GBT: p=0.4800
RF	52.18	8	RF vs. CTREE: p=0.0000 RF vs. GBT: p=0.0000
CTREE	26.79	3	CTREE vs. GBT: p= 0.6214
GBT	29.54	15	-

The t-test has shown that the difference between the mean errors of the RF model and other three models is significant on the 5% level, while the difference between other models is not statistically significant. It revealed that the RF is significantly worse in performance than other three models. Due to the fact that CTREE method has produced the most accurate model with the lowest error of 26.79%, the variable importance in that model was furtherly analyzed by information gain for regression trees calculated as suggested in (Hartshorn, 2016). The procedure has extracted five important predictors as shown in Table 3.

Table 3. First five predictors extracted by CTREE method

Rank	Attribute label	Attribute description
1	V4	Number of users
2	V19	Total number of heat exchangers - radiators
3	V11	Number of level parts
4	V24	Total installed capacity of other heat exchangers
5	V39	Heat transfer coefficient of building components (roof)

It can be seen in Table 3 that the most accurate decision tree model has extracted the Number of users as the most important attribute for natural gas prediction, implying that the occupation of a buildings plays a crucial role in energy consumption of a public building. The second important attribute is the Total number of heat exchangers - radiators, which was expected regarding the fact that the natural gas is mainly used for heating. Two other important attributes also belong to a group of heating variables, namely Total installed capacity of other heat exchangers and Heat transfer coefficient of building components (roof) which shows that heating and occupation groups of variables play important role in predicting natural gas consumption.

## **5. POTENTIALS FOR MODEL IMPLEMENTATION INTO A BUSINESS INTELLIGENCE SYSTEM FOR MANAGERS IN PUBLIC SECTOR**

Establishing a strong business intelligence strategy for natural gas consumption in Croatia's public sector is vital for reduction of all energy consumption. Energy consumption and administration plays a significant role in Croatia's public building due to the fact that public buildings are the largest natural gas consumers. The state government did establish central data source for energy consumption in the form of central Information system of energy management (ISGE). However, the system lacks advanced forward looking predictive analytics. The model proposed in this research can contribute the reduction of energy consumption by using decision tree methods if incorporated into a business intelligence system that could provide effective decision support for managers in public sector. Such model should be implemented in existing information system to produce forecasting models and identify key predictors, allowing managers in public sector to allocate resources in reconstruction of buildings that are the most critical for reducing natural gas consumption. The most convenient way of creating such business intelligence system for energy management includes the following steps: (1) to create web service upon the developed machine learning models, and (2) to incorporate web service into a web application which will serve as a new modul of the existing information system. The technology requirements for such implementation are not too demanding, since the created decision tree model can be exported as a web service in most machine learning software packages, which can be incorporated into a web application as an extension to the existing information system. Web service will allow machine learning models to be implemented in existing information system hosted services and only result data will be moved from existing information system server to one or more locations on the world wide web. Such business intelligence system should allow managers in public sector to have a decision support in allocating resources in reconstruction of public buildings, therefore to achieve higher economic efficiency and return on investment in public sector, as well as its higher energy efficiency.

## **6. DISCUSSION AND CONCLUSION**

The research paper compares the accuracy, variable selection and importance across four decision tree methods: classification and regression tree (CART), random forest (RF), conditional inference tree (CTREE), and gradient boosted tree (GBT) in modelling natural gas consumption of buildings in public sector. The most accurate model was obtained by the CTREE method with symmetric mean average percentage error (SMAPE) of 26.79%. The CTREE method had slightly higher accuracy than CART and GBT. The CTREE, CART and GBT methods significantly outperformed RF method. The contribution of the paper is also in identifying key predictors of natural gas consumption that can be used as an effective decision support for managers in public sector. Variable importance measurement showed that important predictors are generally related to heating data and occupation data. The created model can be implemented into a business intelligence system as an extension of the existing information

system for energy management in Croatia, and could directly decrease expenditures of public sector and improve its efficiency. The future research could be focused to testing more machine learning methods in predicting natural gas and other energy resources, such as support vector machines and deep learning and in analyzing the return on investment in developing the business intelligence system for energy management in public sector.

**ACKNOWLEDGEMENT:** *This work has been fully supported by Croatian Science Foundation under Grant No. IP-2016-06-8350 "Methodological Framework for Efficient Energy Management by Intelligent Data Analytics" (MERIDA).*

#### **LITERATURE:**

1. Apté, C., & Weiss, S. (1997). Data mining with decision trees and decision rules. *Future Generation Computer Systems*, 13(2-3), 197-210.
2. Armstrong, J. S. (1978). *Long-range forecasting: from crystal ball to computer*: John Wiley & Sons Inc
3. Bouabaz, M., Mordjaoui, M., Bouleknafet, N., & Belghoul, B. (2015). Forecasting the energy consumption using neural network approach. In *Progress in Clean Energy, Volume 1: Analysis and Modeling* (pp. 311-320): Springer International Publishing.
4. Breiman, L. (1999). *Using adaptive bagging to debias regressions* (547). Retrieved from Berkeley, CA 94720:
5. Breiman, L., Friedman, J. H., Olshen, R. A., & Stone, C. J. (1984). *Classification and Regression Trees*: Chapman & Hall/CRC.
6. Chen, T., & Guestrin, C. (2016). *XGBoost: A scalable tree boosting system*. Paper presented at the 22nd ACM SIGKDD International Conference on Knowledge Discovery and Data Mining, KDD 2016.
7. Energy, M. f. p. o. t. E. a. (2017). *The fourth national energy efficiency action plan for the Republic of Croatia for the period 2017 - 2019*. Zagreb, Croatia: Croatian Government Retrieved from [https://ec.europa.eu/energy/sites/ener/files/documents/hr\\_neeap\\_2017\\_hr.pdf](https://ec.europa.eu/energy/sites/ener/files/documents/hr_neeap_2017_hr.pdf).
8. Fagiani, M., Squartini, S., Bonfigli, R., & Piazza, F. (2015). *Short-term load forecasting for smart water and gas grids: A comparative evaluation*. Paper presented at the 15th IEEE International Conference on Environment and Electrical Engineering, IEEEIC 2015.
9. Energy Efficiency Legislative Act (2014).
10. Hartshorn, S. (2016). *Machine Learning With Random Forests And Decision Trees: A Visual Guide For Beginners*. In (pp. 74).
11. Hothorn, T., Hornik, K., & Zeileis, A. (2006). Unbiased Recursive Partitioning: A Conditional Inference Framework. *Journal of Computational and Graphical Statistics*, 15(3), 651-674. doi:10.1198/106186006X133933
12. Kokkinos, K., Papageorgiou, E., Dafopoulos, V., & Adritsos, I. (2017) Efficiency in energy decision support systems using soft computing techniques. In: *Vol. 705. Studies in Computational Intelligence* (pp. 33-52): Springer Verlag.
13. Kontokosta, C. E., & Tull, C. (2017). A data-driven predictive model of city-scale energy use in buildings. *Applied Energy*, 197, 303-317. doi:10.1016/j.apenergy.2017.04.005
14. Mitrovic, S., & Zekic-Susac, M. (2017). *A systematic literature review of machine learning algorithms in modeling buildings energy efficiency*. Paper presented at the International Conference on Energy, Environment and Economics, Heriot-Watt University, Edinburgh, UK.
15. Tofallis, C. (2015). A better measure of relative prediction accuracy for model selection and model estimation. *Journal of the Operational Research Society*, 66(8), 1352-1362. doi:10.1057/jors.2014.103

16. Union, E. (2010). Directive 2010/31/EU of the European Parliament and of the Council of 19 May 2010 on the energy performance of buildings *Official Journal of the European Union, L 153, 53*. doi:doi:10.3000/17252555.L\_2010.153.eng
17. Williams, K. T., & Gomez, J. D. (2016). Predicting future monthly residential energy consumption using building characteristics and climate data: A statistical learning approach. *Energy and Buildings, 128*, 1-11. doi:10.1016/j.enbuild.2016.06.076
18. Zekic-Susac, M. (2017, 25.05. - 27.05.2017.). *Overview of prediction models for buildings energy efficiency*. Paper presented at the 6th International Scientific Symposium Economy of Eastern Croatia – Vision and Growth, Faculty of Economics in Osijek.
19. Zekić-Sušac, M., Has, A., & Mitrović, S. (2018). *Recursive Partitioning in Predicting Energy Consumption of Public Buildings* Paper presented at the Central European Conference on Information and Intelligent Systems, Varazdin, Croatia.

## CRITICAL ANALYSIS OF THE MEASUREMENT OF POVERTY: THE CASE OF EMERGING COUNTRIES

**Abdelhamid Nechad**  
ESCA EM, Morocco  
nechad22@yahoo.fr

### ABSTRACT

*Inventors of quantitative estimation of national income, which received much attention, attempted to explain that their ultimate and main interest was the wealth of human existence, although what impressed were their indices, rather than their motivations. Yet, such deep and underlying motivation has often been ignored in economic analysis where means of existence are the centre and fruit of research. It is, however, important not to confuse the means and ends. Therefore, one should not focus on the intrinsic importance of income, but rather assess it depending on what it builds, particularly lives that are worthy of living. Having a decent income helps to avoid early death. Such an enterprise depends also on other characteristics, namely the organization of society, including public health, medical care, the nature of education and educational system, the scope of social cohesion and harmony, etc. Considering only means of existence or directly observing the type of life people lead constitutes a real difference.<sup>1</sup> These observations and findings reveal a contrast between the approaches based on utility and resources and the approach based on capabilities, of which the initiator is Amartya Sen (Nobel Prize of economics in 1998). The capabilities approach, therefore, attempts to put things right by focusing on the possibility of effective ends concrete freedom of attaining reasoned ends, rather than focusing on means. The present paper falls into two parts. The first part will try to highlight the imperfection of traditional monetary indicators as well as the difficulties to measure the different dimensions of poverty, particularly in emerging countries, such as Morocco. We argue that poverty is not merely an idea of inadequacy of economic means of an individual, but rather a fundamental shortage that deprivation entails\_ minimum adequate capability. The second part deals with a reorientation towards capabilities in order to explain the extent to which the latter (the capabilities approach) could serve as a basis for the assessment of the level of deprivation and not that of resources, which focuses on income and wealth. The nature of real existence has always been of interest to social thinkers over the centuries. If the current criteria of economic progress, reflected by a swarm of “turnkey” statistics, focused on growth of inanimate “comfort objects” (such as GNP and GDP at the heart of innumerable economic studies on development), this focus can only be justified, if at all, by the impact of the said objects on human lives that they directly or indirectly affect.. The interest of replacing them by direct indicators of the quality of life, wellness and freedom that human lives enjoy is more and more recognized. Even inventors of quantitative estimation of national income which attracted much attention and adherence tried to make it clear that the ultimate interest was the richness of human existence, although it is their indices, rather than their motivations which had a great impact. William Petty, for example, the pioneer of the measure of national income in 17th Century (He suggested means to assess it so much through the ‘income’ method as through that of expenses, as is said today) formulated his intention as follows: to examine whether « the subjects of the kind » lived « in as bad a condition as that of discontented people ». Based on this, he explained the different determinants of people’s conditions, including « common safety» and « the particular happiness of every man»<sup>2</sup>. This underlying motivation was often ignored in economic analysis where means of existence were*

---

<sup>1</sup> SUDHIR A. and RAVALLION M (1993), “Human Development in poor countries: On the Role of Private Incomes and Public Services” *Journal of Economic Perspectives*, vol. 7.

<sup>2</sup>HUL C.H. (1899), *The Economic Writings of Sir William Petty*, Cambridge, Cambridge University Press,

*the centre and fruit of research. It is, however, important not to confuse the means and ends. Therefore, one should not focus on the intrinsic importance of income, but rather assess it depending on what it builds, particularly lives that are worthy of living. Having a decent income helps to avoid early death. Such an enterprise depends also on other characteristics, namely the organization of society, including public health, medical care, the nature of education and educational system, the scope of social cohesion and harmony, etc. Considering only means of existence or directly observing the type of life people lead constitutes a real difference. These observations and findings reveal a contrast between the approaches based on utility and resources and the approach based on capabilities, of which the initiator is Amartya Sen (Nobel Prize of economics in 1998). In his work entitled « A New Economic Model», Sen suggests that focus on means of existence should be abandoned in favor of concrete possibilities to live. This also results in a change with regard to means-oriented assessment methods, namely those laying emphasis on what John Rawls refers to as the « primary goods », which are general means, such as income, wealth, powers and prerogatives of functions, social bases for self-respect., etc. The capabilities approach, therefore, attempts to put things right by focusing on the possibility of effective ends and on concrete freedom of attaining reasoned ends, rather than focusing on means. Thus, the present paper is divided into two parts. The first part will try to highlight the imperfection of traditional monetary indicators as well as the difficulties to measure the different dimensions of poverty, particularly in emerging countries, such as Morocco. We argue that poverty is not merely an idea of inadequacy of economic means of an individual, but rather a fundamental shortage that deprivation entails\_ minimum adequate capability. The second part deals with a reorientation towards capabilities in order to explain the extent to which the latter (the capabilities approach) could serve as a basis for the assessment of the level of deprivation and not that of resources, which focuses on income and wealth.*

**Keywords:** *Critical Analysis, Emerging countries, Measurement of poverty, National income, Wealth*

## **1. ANTINOMIES OF TRADITIONAL INDICATORS**

After World War II, economic growth was the centre in the fight against poverty. In fact, growth was considered as a means to achieve development. Thus, the growth of the GDP per capita became the only measure of poverty. Pigou was the first to rely on income to measure prosperity and welfare. He described economic prosperity as the measurable part of human wellness, the part that can be compared to money standard or benchmark. However, the production and distribution process impacts the income of individuals and households. Income is, then, is also an indicator of economic activity. Income nationwide, GNP, as it was referred to, was transformed into a measure of the activity of the total mass of produced goods and services, weighted by their respective quantities and prices, rather than a measure of individual welfare. GNP per capita is obtained by dividing GNP by the country's number of inhabitants. Consequently, a country's GNP may increase from one year to another, and its GNP per capita may decrease if the population of this country increases more rapidly than its production. For OECD ( Organisation for Economic Cooperation and Development) countries, international trade relations are such that it was necessary to replace GNP by GDP, which is the sum of added values created within the borders, whatever the nationality of the people who create them. It is the criteria of residence that is prioritized. It should be noted that GNP or GDP indicate a « production» and not « a living standard ». According to certain stakeholders, in order to obtain a country's standard of living depending on its GNP, it is necessary to apply coefficients ranging from minus three to five as per the weight of capital in accumulated in the past, the country's political and economic systems, its geographical and climatic elements, the value of the currency and the weight of the informal sector.



In any event, there exists a certain correlation between poverty and low income. Income is the source of purchasing or spending power, access to consumption and saving. In societies where market values are dominant, « a low income restricts access to the market and can determine a less valorized social status; it is a factor of a more or less marked exclusion»<sup>3</sup>. Nevertheless, one cannot put forward that there exists a high causality between a low GNP per capita and poverty. One cannot claim that that a person dependent on a low income is automatically considered poor. On the one hand, income is but the monetary element of the allocation of each individual's resources. Various elements can intensify or attenuate the consequences of low income: self-subsistence, reciprocal counter-services, existence of property, constitution of family or extra-family solidarity networks, etc. On the other hand, income is not a necessarily determining component of a poverty condition. From the « resources», point of view, income level at a given time has no indication as to prospects of future income, which would undoubtedly be more legitimate. Moreover, as Amartya Sen, in his book « A New Economic Model» shows, the same income can have different meanings depending on age, status, aspirations, etc. The calculation of GNP per capita is subject to many statistical difficulties. In his work «Towards a new measuring system», elaborated jointly with Sen and Jean Paul Fitoussi, Joseph Stiglitz raises asks the following question: « What significance does the the calculation of the importance of a physical production flow take on if account is taken of the conditions of its production and distribution between the concerned persons?»<sup>4</sup>. It is , thus, necessary to underline the problem of distribution of national wealth poses major difficulties. In fact, a growth rate of the GNP per capita can give a flattering image on effective development and ultimately on the poverty combatting strategies. Added to this is the fact that the contradicton between national health and human wellness is very striking. It is apparent in countires where income arising from exports increased significantly due to the rise in oil prices since 2003. For many Arab countires, GNP abruptly increases to levels superior to those of the richest of Western States. However, these same countires sometimes have the poorest communities worldwide. For Joan Robinson, « Economic growth, when it ocured, rarely solved urgent social problems and , most often, did not cover mass population of emerging countries. By making economic inequalities worse and not solving problems, such as unemployment, malnutrition, diseases and housing dificiency, economic growth always excerbated social problems and tensions»<sup>5</sup>. In their work, « Ruins of development » Wolfgang Sachs and Gustavo Esteva support the same point of view. According to them, « Since the rise of prolitariat and, later in the welfare state, poverty was interpreted as lack in purchasing power, which should be eliminated by economic growth. Under the banner of combatting poverty, forcible transformation into moeny economies can be conducted as a moral crusade, which could give way to a so justified appeal to economic expansion»<sup>6</sup>. Besides inequalities concealed by measuring poverty based on GNP per capita, the latter includes all the goods and services produced and marketed, including harmful and noxious products that pollute the atmosphere and affect health. GNP per capita measures production, but provides little information on populations. If deterioration of the environment causes deseases, thus leading to an increase in health expenses and, subsequently, in GNP, such a GNP decrease will be interpreted as a sign of growth and, therefore a drop in poverty, when in fact the population's real conditions and their environment have detriorated. According to the 2010 world report on human development, there were many attempts to recalculate the figures of national income taking into account the natural capital deprciation. One of the first studies carried out to this effect, in Costa Rica, shows that from 1970 to 1990, cumulative depreciation of its forests and oil reserves amounted to over

---

<sup>3</sup> MILANO S. (1988), *La pauvreté absolue*, Paris, Hachette.

<sup>4</sup> STIGLITZ J., SEN A., FITOUSSI J-P. (2009), *Vers un nouveaux système de mesure*, Paris, Odile Jacob.

<sup>5</sup> ROBINSON J. (1980), *Development and underdevelopment* Paris, Economica.

<sup>6</sup> WOLFGANG S. and GUSTAVO E. (1996), *Ruins of development*, Montréal, Ecosociété.

\$ 5billion. , i.e., about 6% of Costa Rica's total GNP for that period. In the case of Indonesia, the same report shows that during the period between 1971 and 1984, cumulative depreciation of forests, soils and oil resources amounted to \$96 billion, i.e., 9% of its GNP for the same period. It is, therefore, commonly accepted that the income-based monetary approach to poverty rests on a narrow idea of welfare or wellness and, because it is indirect, limits our understanding of this phenomenon to what individuals have and what they do not have. Poverty is a larger phenomenon that is apparent in different domains as various forms of deprivation and unsatisfied needs that prevent individuals from leading a normal and decent life or take part in the ordinary activities of society. (Dickes, 1989 ; Alcock, 2006 ; UNDP, 1997). For this reason, it was concluded that adopting multidimensional and direct approaches can prove more satisfactory as to how to perceive poverty, for they have a much broader objective. At this level, it is necessary to distinguish two approaches. First, the approach of situated poverty, which focuses on the prevalence of social construction of poverty since, contrary to what utilitarians pretend, we cannot isolate a phenomenon, such as deprivation, of the environment in which it occurred and developed. This broader concept, which is applied, as a priority, to developing countries, makes it possible to integrate certain dimensions that are not used by Townsend (1979) in the assessment of poverty, such as culture, beliefs and social capital. The second trend derives from the works of Amartya Sen (1980) on the capabilities approach, and which served as the basis for the elaboration by the UNDP of concepts of human development and human poverty. In this case, poverty is defined as a shortfall or deficiency in terms of basic capabilities likely to make it possible for a person to reach what Sen has called fulfilment or achievements. Amartya Sen's aim is to question the relevance of the « *income* » variable in the assessment of poverty. This critical examination holds true for all the different measures which, sharing this vision, perceive poverty in terms of weak or low income.

## 2. SITUATED POVERTY

In order to better understand situations like that of deprivation, we first of all want to better understand situations like that of deprivation, we started with the following questions: Can we limit ourselves to the standard market model to understand the underlying nature of poverty ?

Several times, the determinism of Bretton-Wood's strategies of institutions met with the complexity of the studied fields and facts, a fact which translates into wide poverty in the poorest countries of the globe. Suffice it to remember that Amartya Sen's works confirm the reductionism of the utilitarian idea of the market as to the way of dealing of the nature and causes of the prosperity of nations. Initially, all development policies had as slogan the following slogan: « in the name of combatting poverty as slogan »<sup>7</sup>. For Hassan Zaoual, poverty is understood in a simplistic way. For experts of Bretton-Woods' institutions, the concern is a simple « economic category » that can be calculated from the « income » parameter ». However, in an investigation we conducted in the region of Sefrou (Morocco), we came up with the conclusion that poverty is multidimensional by its very nature. The assessment and analysis of poverty requires adaptation to the diversity of the studied individuals and populations. This is incidentally the reason why we have introduced the concept of « situated poverty ». Amartya Sen paid special attention to the principle of diversity, as is clear from its recurrence in his arguments. He began his work « Rethinking Inequality » by the following formula: « Human beings are different from each other. We are distinguished from each other by characteristics that are not only external ( inherited wealth, the natural and social environment where we live), but also personal (age, gender, vulnerability to diseases, physical and intellectual aptitudes).

---

<sup>7</sup> ZAOUAL H. (2000), « La pensée économique plurielle : une révolution scientifique en marche », *Séminaire de culture de développement*, DEA Changement social, Université des Sciences et Technologies de Lille.

To determine what equality requires, it is necessary to take into account this human diversity»<sup>8</sup>. The remarks of Ibn Khaldoun, « the father of history», clarify this point. This great historian of the 14th century, through a comparative analysis between the eating habits of the populations of Hijaz ( Saudi Arabia) and those of Shanhajas, veiled people of the South of the Maghreb, puts forward that famine is a blessing for the life of the former so much from the physical as on the mental point of view. According to Majid Rahnema « In general, Ibn Khaldoun argues, people who lack grains and condiments and live in the deserts are in better health than the inhabitants of the plains and heights who lead an easy life : their complexions are purer, their bodies healthier, their humours better proportioned and more beautiful, their behaviour not disproportionate, their faculties more receptive and more perceptive in knowledge. It is a remark that has been confirmed for generations»<sup>9</sup>. This justifies the point of view of the sitology approach to poverty, according to which, poverty cannot come down to a general and universal formula where only the « income» variable intervenes, to be later interpreted as a sign of deprivation. It is the individual's life and environment that should be taken into consideration. It is, therefore, necessary to adapt economic analysis of poverty to the context of each location. According to its « soft relativism» principle, the situated poverty approach states that each location or site, while open to changes, exhibits peculiarities that impregnate people's individual and collective behavior within a given location.. « Development policies made numerous « site errors» in so far as they tend to be dropped on from the summit to the base instead of favouring listening to and free participation of concerned populations »<sup>10</sup>. The 2010 world report on human development stresses that: « the sectors of media, information and leisure, which, thanks to their considerable means, are present worldwide, can powerfully help eradicate or, at least, reduce poverty. They shape not only information, but also new culture and values. We need values that tolerate cultural diversity and respect dignity of the poor so as to reinforce their solidarity and mobilize individuals and communities, companies and others against poverty»<sup>11</sup>. It equally stipulates that « Well-focused strategies are necessary so that the growth model could be beneficial for the poor and so that generated resources could be invested in human potentials. Growth is not enough. La croissance ne suffit pas. On its own, it can be without regards (the losers find themselves in grinding poverty), without jobs (almost no job is created), without participation (individuals are not associated to decision-making processes), with no future (the environment of future generations is destroyed) and without roots (history and cultural traditions die out ». Like Amartya Sen, Hassan Zaoual assumes that it is necessary that the poor have an area of freedom so that they can better act, since the crowding out (l'effet d'éviction) will sooner or later end up recurring in the form of non participation which is detrimental to economic performance and local accumulation of skills through economic projects meant to respond to the causes of poverty. According to the same author, the assumed skills of « experts » sustain the site stakeholders' unskilfulness. The poor, thus, are not citizens, but rather customers of institutions and social security. The latter use their expertise without solving the problems that justify their existence. Therefore, there is a new tendency based on the awareness of the role that local cultures and beliefs can play in combatting poverty, a fact which proves to be a first step towards a new concept of combatting poverty and which claims to be situated and therefore open on new anthropological and cultural dimensions of the concerned location. This confirms the contributions of the capabilities for which a better analysis of deprivation assumes a better understanding of the area and populations studied.

---

<sup>8</sup> SEN A. (2000), *Repenser l'inégalité*, Paris, Seuil.

<sup>9</sup> RAHNEMA M. (1991), La pauvreté globale: Une invention qui s'en prend aux pauvres, *Revue Interculture*, Volume XXIV, N° 2.

<sup>10</sup> ZAOUAL H. (2002), « La pensée économique peut-elle être flexible », in Granier R. et Robert R (sous la dir.), *Culture et structures économiques. Vers une économie de la diversité ?*, Paris, Economica.

<sup>11</sup> PNUD (2011), *Rapport mondial sur le développement humain 2010*, Paris, Economica.

### 3. CAPABILITIES APPROACH

During the last few years, there has emerged a growing interest in the idea of « *capabilities* » introduced by Amartya Sen (1980, 1985, 2000, and 2003). If the Nobel Prize that Sen obtained in 1998 is a symbolic proof, it is certainly the more and more widespread use of this approach among researchers and institutions in their understanding of questions related to wellness, poverty and inequalities that is better evidence for this. The capabilities approach is based on ethical concerns related to social equity. In fact, at the beginning of his reasoning, Amartya Sen poses the question of what attribute a society should equalize to achieve social equity. Starting from a thorough and well-founded criticism to the proposals of the two dominating ethical approaches at the time, i.e., utilitarianism (Bentham, 1789) and Rawlsian theory of equity (Rawls, 1971), he suggested a space of functionings and capabilities, such as adequate assessment of questions related to welfare, poverty and inequalities. Thus, in the field of social equity, this approach constitutes a new paradigm and a real alternative to utilitarian orthodoxy. The capabilities approach is an expanded and normative framework for the assessment of issues related to individuals' welfare, social arrangements, policy implementation and societal changes based on individuals' actual ability to do or to be something and the scope of freedom they enjoy to promote and achieve their objectives. This approach starts from the simple remark that an individual's living standard is directly related to the different states and acts they can accomplish or achieve. Sen makes use of the term "functionings" or achievements to refer to these states and acts that individuals effectively attain. For Sen, « the thesis is that functionings are constituents of the person's existence and that the assessment of their welfare should necessarily be a judgment of these components »<sup>12</sup>. The ability to function constitutes all the real opportunities the individual is offered and represents the various combinations of functionings (states and actions) that the individual can accomplish. Capability is, therefore, a set of vectors of functionings which indicate that an individual is free to lead this or that type of life. Thus, on the conceptual level, the main innovation of the capabilities approach is the adoption of an expanded informational space, wider than that of the traditional approach, to deal with a set of normative questions (Farvaque, 2003). As is stressed by Robeyns (2005), the two focal points of this approach are the focus on the distinctions between means and ends, on the one hand, and between real freedom (capabilities) and functionings (outcomes), on the other. Resources are goods and services (commodities), be they mercantile or not, that the individual has at their disposal, as, for instance, food or a bike. These goods have an instrumental value rather than an intrinsic or inherent value, for what really matters is the way we can use them. Also, like Gorman (1956) and Lancaster (1966), Sen (1985a) draws a line between resources and their characteristics which constitute their desirable properties and determine the uses to which the good can be put. It is these functionings that constitute the intrinsic value. A bike enables its owner to move; food does not only make it possible to satisfy hunger, but also brings the pleasure to eat and to create a social support through the organization of meals (Sen 1985). Therefore, the characteristics of goods (bike) provide individuals with the possibility to implement the related functioning (movement). However, Sen (2003, 150) points out that there is nothing automatic, permanent or inevitable about the relationship between income (and other resources), on the one hand, and individual achievements and freedoms, on the other. In fact, owning a good is different from the ability to benefit from its characteristics. It is not enough to know the quantity of food an individual has to judge the way they are fed. Sen's well-known example is that of an individual suffering from a parasitic disease that makes the digestion of food difficult. This person can suffer from malnutrition, even if they have at their disposal a quantity of food that would enable an individual without such disease to be well fed.

---

<sup>12</sup> Sen A. (1999), *L'économie est une science morale*, Paris, La Découverte.

Thus, information of goods ownership proves insufficient to judge someone's living standard or welfare, for it does not take into account of the relationship between goods and functionings. To be able to take account of such contingent relationship, Sen introduces, at the heart of his approach, a set of internal and external conversion factors, which determine the possibility to convert the characteristics of resources into functionings. First of all, such transformation will be influenced by personal conversion factors related to the individual's internal characteristics (physical, intellectual aptitudes, metabolism, etc.). A person suffering from physical disability will not be able to achieve the characteristic « movement » that the good has « bike ». In the case of food, metabolism, age, gender, activity level or health conditions are conditions that will influence the way the individual will indeed convert resources (food) into functionings (to be well-fed). Besides, age and gender determine specific needs that income does not take account of (young children, old people, maternity, family obligations). The other conversion factors are external and highlight the influence of social characteristics (politics, social norms, power relationships) and environmental characteristics (climates, infrastructures, public goods) may exert. A country's social rules and traditions may constrain women's behavior, thus reducing all their potential functionings. Likewise, riding a bike may depend on climatic conditions and usability of a country's roads, the ability to be well-fed may depend on drought or flood problems and the ability to be in good health depends on risks of contagious diseases in the region of residence. Therefore, taking account of these different conversion factors will make it possible to consider interpersonal variations, which enables individuals with identical resources may have two different living standards. This last point is particularly important within the framework of the elaboration and assessment of public policies aiming at reducing poverty (Sen, 2003). In the course of Sen's reasoning, it is important to understand the distinction between functioning and capabilities. Functionings are individuals' different states and acts. They form what a person, given a set of conversion factors, can do or be. They can be elementary (i.e., to be well-fed and in good health) or complex, such as the ability to take part in community life, take a rest, be respected, have self-esteem, etc. Assessment of welfare, therefore, takes the form of an assessment of functioning vectors (i.e., individuals' valued states and acts). Reference to functionings makes Sen's approach a direct and multidimensional one. Indeed, although he considers that an individual's welfare should depend deeply on the nature of their existence, that (i.e., accomplished functionings), at the heart of his approach, he places capabilities rather than functionings. As is highlighted by Robeyns (2003), while a functioning is an achievement, a capability represents the possibility of achievement and refers to all potential functionings. Consequently, Sen's emphasis is not on what people have or do, but on what they have the choice to do or do not have the choice to do. Based on all the characteristics of the resources at their disposal and on the conversion factors, an individual can determine vectors of potential functionings that represent the different combinations of potential functionings they can achieve. This set represents all the individual's capabilities and gives an image of the scope of the choices at their disposal. It, therefore, precedes all functionings which constitute all the states and acts that an individual achieves. Moving from the space of capabilities to that of functionings is shown by the individual's real choice, which, in turn, depends on the individual's history as well as on the mechanisms of preferences; these mechanisms themselves depend on the social context. In Sen's view, functionings are more related to living standards, whereas capabilities result in a dimension of freedom and choice. In fact, capabilities refer to an individual's real freedom and real opportunities, and the freedom, in the positive sense of the term, which an individual has to promote or achieve a functioning they would like to enhance. To illustrate the importance of the difference between capability and functioning, we can cite the example of two people who cannot sufficiently provide for their needs in terms of food. However, one is a person suffering from famine whereas the other is a person who has chosen to be on hunger strike as a sign of protest. Regarding the good

“food”, both people realize the functioning of being “malnourished”, but not through the same path.; while one of them was forced into such a situation, the other one has made a choice. The notion of choice is not easy to understand. One finds the same questions asked in works on deprivation in which involve determining whether choices are forced or deliberate. Based on these considerations, Sen suggests a distinction between living standard, welfare and « agency». For him, the living standard is the broadest notion and is connected with information related solely to the individual. The difference between the living standard and welfare emerges from the possible influence of external sources on a person’s welfare. Thus, pain (joy) caused by sorrow (happiness) of a relative reduces (increases) welfare, but does not affect the living standard. Agency is much broader and rests on the idea that an individual can have objectives and values other than the search of their personal comfort. An example is a person’s commitment towards the issues of their community through the participation to anti-globalization protests, being persuaded that this globalization has harmful effects (Robeyns, 2003). These various concepts constitute the backbone of the capabilities approach, of which the use, as a framework of thought, is very wide and is confined to studies of poverty. The capabilities approach to poverty constitutes a way to move from the analysis of means to the analysis of ends. In this context, Sen (2003, 36) considers that « it is just to consider poverty as deprivation of the basic capabilities, rather than merely a low of income». This definition of poverty refers to a shortfall or deficiency of basic capabilities. The latter constitute a subset of the set of “capabilities” and refer to the freedom to achieve basic things that are necessary to survive and to avoid or escape poverty. Thus, while capabilities can cover a vast and varied field, basic capabilities refer precisely to the real possibility to avoid poverty. They concern the ability to satisfy minimum and adequate levels of certain crucial functionings. The identification of these minimum and acceptable levels constitutes the basis of Sen’s approach to poverty. For Robeyns (2005, 101), basic capabilities are crucial to analyze poverty and, in more generally, to study the welfare of the majority of the population in a developing country, whereas in rich countries, welfare focuses rather on capabilities that are more or less necessary for physical survival. Therefore, from the outset, this definition is broader than given by....., but it is more subtle and delicate to make operating. The capabilities approach is the development paradigm that is underlying the concepts of human development and poverty introduced by the UNDP (1990, 1997). One of the major changes that this new paradigm offers is the possibility of analyzing the different questions regarding poor countries and individuals within a flexible framework, rather than imposing political or other prescriptions in the name of a rigid neoliberal orthodoxy (Fukuda-Parr, 2003). Within the framework of this approach, human development is geared towards the expansion of capabilities, whereas human poverty reduction involves ensuring that individuals who should have to primary resources have a set of basic capabilities likely to help them achieve these resources. The main difference between the concepts of human development and human poverty is that the former focuses on the living conditions of all individuals in society while the latter lays emphasis on those of poor individuals. Thus, as part of the overall view of human development, the disadvantages of the poorest people can, in an aggregated level, be made up for by the gains of the well-to-do ones. The concept of human poverty and poverty indices were introduced in order to focus on the situation of the most underprivileged people. In this case, lack of progress in the reduction of disadvantages of people in deprivation cannot be made up for by the significant progress of the well-to-do. Subsequently, Anand and Sen (1997) consider that the two approaches are useful for understanding the development process, and that they are not exchangeable. The human poverty approach was introduced by the UNDP’s 1997 Human Development Report. This report seeks to focus on the challenges of poverty eradication in the world with a view towards human development.. For this purpose, it does not simply focus on poverty, in the monetary sense of the term, but rather on a multidimensional approach to poverty. (Anand and Sen, 1997).

It draws its inspiration, to a large extent, from Sen's capabilities approach, as is shown by the introductory phrase of the first chapter of the 1997 Human Development Report., which stipulates that « It is the deprivation lives that people may lead that poverty can be seen. Poverty implies not only low income or deficiency in elements necessary to well being, but also denial of and deprivation in opportunities and basic choices for living a tolerable life». These choices and opportunities refer to basic capabilities. This means that, in this approach, poverty is not merely a state of deprivation currently lived by an individual, but also the absence of real opportunities, due to social constraints or to personal characteristics, for living a life that they reasons to valorize. Nevertheless, with poverty being a state that everyone one wishes to avoid, it may be said that its study can disregard this notion of freedom and focus on the individual's real functionings. This approach largely exceeds the physiological model of deprivation, for « capabilities » mean, « to be in good health, have access to knowledge, have access to resources necessary to have a decent standard of living and be able to take part in the community's social life » (PNUD, 2001). From a political point of view, the objective is, therefore, the « removal of obstacles in what one can do in life, obstacles such as illiteracy, diseases, insufficient access to resources, or insufficient political and civic rights » (Fukuda-Parr, 2003). Fukuda-Parr (2003) evokes a five-point strategy for development and poverty reduction: (1) give priority to social development with a spread of opportunities of education and health care., (2) economic growth creating resources for multidimensional human development, (3) social and political reforms in view of establishing a democratic governance to secure all people's rights, (4) foster equality in the three preceding points, namely for the poorest people (5) global political and institutional reforms to create an economic environment where access to markets, technology and information would be easier for poor countries. Within these diverse components, one can notice the rise of the concept of empowerment (World bank, 2000 ; Narayan, 2002) and the increasingly accrued taking into account of questions related to gender equality. The capabilities approach has led to clear conceptual advances in the field of poverty studies, both as to the debate on the absolute or relative aspect of poverty and as to its role in the appearance of the concept of human poverty. These conceptual advances are nevertheless are confronted with important operationalization problems, which are partly due to the scope of this approach.

#### **4. OPERATIONALIZATION OF THE CAPABILITIES APPROACH**

The great riches and complexity of Sen's approach are not easy to express empirically, for the capabilities approach is much more demanding on the informational and methodological level than on the monetary level of poverty. If for some people, the problems facing this approach seem to be insuperable, for others they are simply a reflection of the intrinsic and irreducible complexity of the concepts it makes possible to understand. Such is Chiappero Marinetti's (2000) point of view, who stresses that the empirical applications of the capabilities approach require an adequate space for the evaluation of capabilities (or functioning), a pertinent list of capabilities and functionings, a set of indicators for each of the dimensions of wellness taken into account, the way, if necessary, to combine the elementary indicators to obtain an assessment on each dimension of wellness and the way to add information on the different dimensions and achieve a comprehensive assessment of wellness. Assessment of capabilities requires that, on the one hand, valuable items be selected and, on the other hand, the value of these items be determined (Sen, 2000). In fact, beyond the preceding, there emerges the problem of the list of elements to consider and their relative importance. This question is related to the horizontal imprecision of the capabilities approach. Sen's reference to the different states and acts, which a person has reasons to valorize suggests that this approach is inherently multidimensional and refers to a multitude of functionings/ capabilities, which can impact individuals' wellness.

In the case of the study of poverty, confining oneself to a set of basic functionings makes it possible to limit their number. However, even at the level of basic functionings, Sen's capabilities approach does not provide a list of functionings/ dimensions, nor does it provide a clearly defined selection method. This question is of paramount importance and is recursively at the heart of the current debates on the operationalization of this approach (Robeyns, 2005). Indeed, although Sen's theory is theoretically attractive, as long as one does not have clearly defined criteria for the selection of value functionings, one will face a series of criticisms. In particular, the absence of a list makes Sen's approach is not fully specified. Absence of a list makes Sen's approach not completely specified. For some researchers, this incompleteness poses a problem. Nussbaum (2003) considers that as long as Sen has not explicitly determined a list, his approach will lack percussion. Alkire (2001, 2002) shares the same point of view. She considers that lack of a procedure for the identification of pertinent capabilities (dimensions) makes the implementation of this approach difficult. These two authors agree that, in this case, the approach may be not understood and may give free reins to all sorts of deviations. In fact, without a list or a transparent selection method, numerous works aligning themselves with this theory may adopt different approaches or steps, which will lead to more confusion than clarity. Other authors leveled stronger criticisms. Townsend (1985, 667), for instance, argues that the absence of scientific criteria for the selection of dimensions is « scientifically unacceptable ». For him, « one should consider the question of knowing how capabilities are selected and in what way they are absolute ». In the same vein, Sugden (1993) raises the following question: «given the large number of functioning that Sen considers as pertinent, given the scope of disagreement between reasonable people as to the nature of what is a descent life and given the unsolved problem of the way in which sets should be assessed, it is natural to raise the question of knowing the extent to which Sen's framework of analysis is operational ». In reply to these criticisms, Sen admitted that it is necessary not only to identify the capabilities and classify them into the most central ones and the most trivial ones, but also to assess their relative weight. However, he thinks that any subsequent specification on his part would be controversial. In fact, while he is not averse to the idea of determining that, in some specific cases, certain capabilities are more important than others, he refuses to endorse the a predetermined and definite list of capabilities. The reason for this is that the capabilities approach is not confined to a sole objective. It was elaborated as abroad framework of thought. Consequently, Sen believes that each application necessarily depends on its context and it for this reason that his approach was deliberately incomplete. The selection of capabilities should therefore be geographically contextualized. Thus, from a methodological point of view, « they are applications to specific questions, context-sensitive and limited by data, which can give birth to a pertinent list » (Farvaque, 2003). Besides, the elaboration of the list pertains to a value judgment that should be explicitly made through a democratic and participative method. It is not the work of a theorist. It is, therefore, clear that if the malleability of this approach makes it evasive in the eyes of certain people, Sen considers it as an asset and thinks that this approach cannot be made more specific without carrying out a universal assessment, which will make it possible to choose the valuable items and their relative weight. Thus, while this incompleteness is the point which leaves this approach wide open to the most ferocious criticisms, it is one of the reasons of its success. If he refuses to give a list of basic functionings, Sen nevertheless lays tracks that will help understand the scope he intends to give to his approach. These tracks are in the form of domains that one can take into consideration and the form of two selection criteria, based on consensus, which will make it possible to select the set of pertinent, basic capabilities without having recourse to value judgments.



## 5. CONCLUSION

In spite of incompleteness that Ammatya Sen's approach exhibits, it should be nevertheless admitted that any poverty reduction policy that does not take into consideration the capabilities of individuals or groups of population increases deprivation. In other words, any person's emancipation and « well being» depends on their capability to change their situation. Increase in income does not automatically lead to the improvement of « well being» when the individual as well as their environment are not able to develop relying on their endogenous capabilities. Therefore, the problem lies in the inadequacy and not the lowness of income. Having an adequate income does not mean having an income that is inferior to a poverty threshold set from outside. Instead, it is having an income lower to what a person should have to ensure a specific level of capability. This means that, to analyse poverty, one should not confine oneself to data on income<sup>13</sup>; it is necessary to pay particular attention to the diversity of environments and social phenomena. According to Sen, « An analysis of poverty based solely on income will only say half the truth».

## LITERATURE:

1. Abdelmalki L. et Courlet C. (1996), *Les nouvelles logiques du développement*, Paris, L'Harmattan.
2. Amin S. (1973), *Le développement inégal*, Paris, Les éditions de minuit.
3. Assidon E (1990), *les théories économiques de développement*, Paris, La Découverte.
4. Benabdellali N. (1999), *Le Don et l'anti-économique dans la société arabo-musulmane*, Rabat, Eddif.
5. Bneatham J. (1789), *The principales of morales and legislation*, Hafiner Press, Londres.
6. D'Autume A., et Cartelier J. (1995), *L'économie devient-elle une science dure?*, Paris, Economica.
7. Dickes (1989), *Pratique de l'échelonnement multidimensionnel, de l'observation à l'interprétation*, Paris, De Boek,.
8. Esteva G. et Sachs W. (1996), « *Des ruines du développement*», Bruxelles, Ecosociété.
9. Farvaque E. (2009), *Economie de la démocratie*, Paris, De Boeck.
10. Ferreol G. (1992), (sous dir.), *Intégration et exclusion dans la société française contemporaine*, Presses Universitaires de Lille.
11. Ibn Khaldoun (1956), *Al-Muqaddima*, Beyrouth, Tome I, Dar al-Kitab al-lubnani.
12. Milano S. (1988), *La pauvreté absolue*, Paris, Hachette.
13. Milano S. (1992), *La pauvreté dans les pays riches : du constat à l'analyse*, Paris, Nathan.
14. Parr F. (2003), *Capacity for development : New Solutions to old problems*, New-York, Taylor and Francis.
15. Rahnema M. (2003), *Quand la misère chasse la pauvreté*, Paris, Fayard.
16. Rawls J. (1971), *Théorie de la justice*, Paris, Essai.
17. Robinson J. (1980), *Développement et sous-développement*, Paris, Economica.
18. Salama P. et Valier J. (1994), *Pauvreté et inégalité dans le Tiers-Monde*, Paris, Edition La découverte.
19. Salama P. et Destremau B. (2002), *Mesure et démesure de la pauvreté*, Paris, PUF.
20. Sen A. (1993), *Ethique et économie*, Paris, PUF.
21. Sen A. (1993), *L'économie est une science morale*, Paris, La Découverte.
22. Sen. A. (1998), *un nouveau modèle économique: Justice, démocratie, liberté*, Paris, Economica.
23. Sen A. (2000), *Repenser l'inégalité*, Paris, Seuil.

---

<sup>13</sup> Instead of measuring poverty based on income, Sen suggests calculating one can achieve with this income, while taking into account the fact that these achievements can vary from one individual to another and from one place to another. Otherwise, how can we explain that there exist poverty pockets inside middle classes in rich countries?

24. Sen A. (2000), *Un nouveau modèle économique : Développement, justice, liberté*, Paris, Odile Jacob.
25. Stiglitz J. (2002), *La Grande désillusion*, Paris, Fayard.
26. Townsend P. (1979), *The concept of poverty*, Heinmann, Londres.
27. Wolfgang S. et Gustavo E. (1996), *Des ruines du développement*, Montréal, Ecosociété.
28. Zaoual H. (2002), *Du rôle des croyances dans le développement économique*, Paris, L'Harmattan.

## EU INTRA-MOBILITY CAPACITY OF RESILIENCE

**Solange Maslowski**

*Center for Comparative Law,  
Faculty of Law, Charles University, Czech Republic*

### **ABSTRACT**

*EU-intra mobility is under numerous challenges, that endanger its current features and future. To face political, economic and social challenges, EU intra-mobility legislation needs more resilience. Trials often put on the spotlight weaknesses and gaps that should be filled. The incompleteness of EU citizenship and the discordance between EU legislation and Member States' practises have to be dealt with. Resilience also requires a set of properties such as flexibility, legal certainty, consensus on core institutes, coherence and solidarity. The article will explore each of these properties in relation to current challenges and propose potential paths. It will also address the benefits of a better resilience for EU citizens, EU Member States and the European project in general.*

**Keywords:** *EU Citizens, Free movement, Gaps, Legal certainty, Resilience*

### **1. INTRODUCTION**

EU-intra mobility, one of the best success of European integration, has been under numerous challenges since a decade, following the occurrence of political, economic and social changes. Unfortunately, its past achievements and its current shape seem not sufficient to face the new trials. For this reason, EU intra-mobility needs a better resilience to face multi-faceted challenges. The first trial is linked with the intensification of the migration of EU citizens, rather poor after the enlargement of the EU to CEECs (from East to West) and the global financial crisis (from South and East to North). Until then in favor of freedom of movement of EU citizens, some Member States started to fear for their national budget and for a potential abuse of their social security system. The refugee crisis, which is putting Member States under pressure, just increased these fears. Besides these economic threats, there is a second and more serious threat, the questioning of the European project by attempts of backward steps like the Brexit or the rise of anti-European populist movements in different Member States. These different challenges also conducted to a questioning of the current shape of the free movement principle. Core elements of EU-intra mobility legislation have been at issue and further deepening do not seem up-to-date. Indeed, even the core and old rights of EU mobile workers have been under discussion (debates around the Brexit referendum). It is not then surprising that the rights of the economically inactive EU citizens are also questioned. There are indeed requirements of a stricter punishment of abusers of social assistance by some Member States (Joint Letter, 2013) and the Court of Justice of the EU is lastly favoring a stricter access to social assistance for economically inactive EU citizens on the move (Dano, 2014; Alimanovic, 2015; Nieto, 2015; Commission v. UK, 2016). Of course, some threats are founded while other are just mere myths but all of them have to be taken seriously as they could cause serious damages to the fundamental right of freedom of movement. In order to avoid a backward step, EU intra-mobility has to overcome its current weaknesses and get new tools to overcome growing global challenges. The first chapter will address current shortcomings of the EU intra-mobility legislation and the second chapter will propose some tools that could help Freedom of movement of persons to be more resilient.

### **2. EU INTRA-MOBILITY SHORTCOMINGS AND GAPS**

Since the beginning of the European project, EU intra-mobility has developed towards more rights and protection for the EU citizen on the move.

But similarly to other fields of European integration and despite of its successful steps, freedom of movement of EU citizens is not yet totally achieved. It is still in progress as the EU citizen moving to the territory of another Member is still facing many difficulties. But it seems that the time of consolidation of rights or of acquisition of new rights is over. We moved recently towards a restrictive approach of the use of the rights of the EU migrant, shown by the recent jurisprudence of the Court of Justice of the EU and the increase of national legislations restricting access to social assistance. This new dynamic is worrisome as there are still gaps that should be filled in the field of freedom of movement. Indeed, despite far-reaching progresses, there are still differential treatments for EU citizens on the move. And their EU citizenship seems not to be able to fill the gaps as it was the case before. Moreover, some Member States, not satisfied with the EU intra-mobility legislation, go further and don't hesitate to expell EU citizens without regard to procedural and material safeguards provided by Articles 28, 30 and 31 of Directive 2004/38/EC.

## **2.1. Differential treatments for EU citizens on the move**

Freedom of movement of EU citizens does not provide yet for total equality of treatment between EU migrants and nationals of the hosting Member State. This differentiation of treatment has a legal ground. But there are also States' practises against a certain category of migrants, which are not legally founded.

### *2.1.1. Economically active and inactive migrants*

Indeed, if the first provision of Article 24 of Directive 2004/38/EC declares that all Union citizens residing in the territory of the host Member State shall enjoy equal treatment with the nationals of that Member State, the second provision adds derogations for economically inactive EU citizens. Only EU mobile citizens, who are workers or long-term residents can enjoy equal treatment. Economically inactive migrants like students, retired persons and job-seekers don't have entitlement to social assistance during the first three months of residence or, where appropriate, a longer period (provided for in Article 14(4)(b)), or prior to acquisition of the right of permanent residence. The restrictive nature of EU legislation towards EU citizens economically inactive is consolidated by some Member States' preventive measures. So, in 2016, the German government has adopted a draft bill restricting access to social assistance for EU job-seekers, who will have to wait 5 years of residency (Le Monde, 2016).

### *2.1.2. EU migrants from Roma origin*

There is also, in practise, another differential treatment towards EU mobile citizens from Roma origin. Roma EU citizens cumulate indeed different parameters, that make them less well treated than other EU mobile citizens. As economically inactive, most of them already don't benefit from equality of treatment and have a restricted access to social assistance. But they also belong to the poorest category of economically inactive EU citizens, of those who are not self-sufficient. This category of EU migrants is the most feared by Member States, which are scared of welfare tourism and of unreasonable burden on their social security system. Roma EU citizens are also viewed by some Member States as a threat to their public order because of their specific way of living, often due to their extreme poverty. So, petty crimes like illegal occupation of public premises, prostitution or begging will lead easily to their expulsion. For these reasons, EU citizens from Roma origin are often perceived as under-class (Lhernoud, 2011)/ illegitimate (Lafleur, Stanek, 2017) /bad (Phoa, 2015) /abnormal (Carrera, 2014) EU migrants despite measures taken by the EU Commission to better integrate the Roma (EU Commission, 2017). Here, there is clearly still work to do towards the achievement of EU values such as solidarity, fight against social cohesion and discrimination, ever closer union amongst the people of Europe.

## **2.2. Uncomplete EU citizenship**

EU citizenship established by the Maastricht treaty and conferring a number of rights to nationals of the Member States has been considered as their fundamental status ( Case Grzezyk, 2001). So, the Court of Justice of the EU relied upon this status to confer social assistance to economically inactive EU citizens while EU legislation was restricting such access. Such approach let believe to an increasing empowerment of the status of EU citizenship. Unfortunately, EU citizenship lacked of resilience in front of growing fears of EU Member States for their national budget. Nowadays, EU citizenship has lost its significance and is not anymore able to thwart EU european and national restrictive measures. This shows that the use of EU citizenship can vary from one period to another, with possibilities of regression. EU citizenship could have grown up towards more protection for the EU citizen on the move, especially in matters of expulsions. It could allow the application of a *droit pénal de l'ami* to EU citizens (D'Ambrosio, 2011) instead of a *droit pénal de l'étranger*. Indeed, while national citizenship prevents States to expel their own citizens, EU citizenship is not yet able to prevent the expulsion of EU citizens from their hosting Member State. At a time when Europe is equated with sovereign debt and political powerlessness, one should not forget that the foundations for a European citizenship have already been laid. Its potential for democracy needs to be interrogated, as do the cultural resources that it can rely on (Guénard, 2011).

## **2.3. Discordance between EU migration law and Member States' practises**

Last decade has shown that some Member States don't hesitate to go beyond EU internal migration law. Cases of abuses of expulsion powers are numerous, much more than abuses of social assistance by EU citizens on the move. It was the case of collective expulsion of Romanian and Bulgarian citizens from Roma origin in France in 2010, of non-self sufficient EU citizens from Belgium in 2013 or current expulsions of EU citizens from the UK. Statistics on the numbers of expulsions of EU citizens on the move is worrismatic: in 2016, 1918 EU citizens have been expelled from Belgium among them were Romanian, Bulgarian, Dutch, Italian and Spanish citizens and in the UK, 1000 expulsions were recorded just for the very beginning of 2017.

## **3. TOOLS TOWARDS MORE RESILIENCE**

The shortcomings and the incompleteness of the freedom of movement make it difficult for this fundamental right to be resilient in front of current trials. To face political, economic and social challenges, EU intra-mobility legislation needs more resilience. This resilience requires a set of properties such as flexibility, legal certainty, consensus on core institutes, coherence and solidarity. While in some fields more flexibility is required, in others more normativity is needed.

### **3.1. Flexibility through the individual approach**

Flexibility is needed especially to take into account the diversity and the economic disbalances between the 28th Member States. As an example, the requirement of self-sufficiency from Article 7 of Directive 2004/38/EC is based upon the level of the threshold under which a minimum subsistence benefit is granted in the host Member State. It does take into account the level of the country of origin of the EU migrant while an EU migrant from a poorer Member State has learnt to live with a much lower amount of money than those of richer Member States. The individual capacity of managing his or her personal budget by a migrant should be taken into account as far as there is no unreasonable burden. In fact, only the individual approach recommended by the EU Commission and the CJEU allows to include such considerations. This approach requires to take into account the personal situation of each individual. It is clearly illustrated by Article 28 that states that the host Member State shall take account of

considerations such as how long the individual concerned has resided on its territory, his/her age, state of health, family and economic situation, social and cultural integration into the host Member State and the extent of his/her links with the country of origin.

### **3.2. Legal certainty and more consensus on core institutes**

In the field of freedom of movement of persons, legal certainty is certainly endangered by the absence of definition of core legal institutes, leaving a too important margin of appreciation to Member States. These institutes which are legal grounds limiting the fundamental right of freedom of movement are, in fact, very sensitive matters for Member States and the symbol of their sovereignty. Hence, their reluctance to agree on common criteria. This is the case for the institutes of »threat to public policy and threat to public security«. Member States retain indeed the freedom to determine the requirements of public policy and public security in accordance with their needs, which can vary from one Member State to another and from one period to another (Case 36/75 Rutili, para 27). It means that an EU citizen can be expelled in one Member State for begging, considered as a threat to public policy in a given country while he would not be expelled in another Member State not considering this act as a threat. In the field of abuse of social assistance, the institute of unreasonable burden is also unclear. It is in opposition with the individual approach that should be used while examining the case of each migrant. Indeed, it is difficult to imagine that one individual abusing social assistance is able to endanger the whole state budget (Hailbronner, 2006).

### **3.3. Solidarity**

The questioning of freedom of movement of EU citizens is nowadays mainly based upon the calling into question of the conferral of social assistance to economically inactive EU citizens. Some Member States are fearing that an important number of applications to social assistance will become an unreasonable burden on their social security system. Times of financial solidarity between Member States supported in the past by the Court of Justice of the EU is over (Cases Martinez Sala, 1998 and Grzeczyk, 2001). Indeed, the relationship between freedom of movement and access to social benefits is becoming increasingly contested in a number of large EU member states (Guild, 2013). It has been proved already that there is no abuse of social assistance in a large scale and only a few use of this right by EU citizens on the move. But it might happen that, temporarily, some region or municipalities can be burdened by a large number of applications (EurActiv, 2014). In this case, a preventive solution should be found. Member States should agree on a mechanism allowing the temporary conferral of European funds to overburdened national administrations. Different solutions have been proposed regarding the source of these funds: the European Social Fund (Fernandez, 2016) or the creation of a »mobility fund«- inspired by the »European Globalisation Adjustment fund« which would allocate European financial assistance to municipalities under particular pressure as the result of a high influx of EU citizens (Sorensen, 2014).

### **3.4. More public evidence and transparency**

There is a clear need for more objective evidence backed with figure and data proving the existence or absence of abuse of their rights (mainly social assistance) by EU citizens on the move. Fears are sometimes born from a lack of knowledge on the true scale of a given issue. For example, different national surveys ordered by the European Commission (DG Employment, Social affairs and Inclusion, 2013) and the European Parliament (European Parliamentary Research Service, 2014) had proved that EU citizens on the move apply less to social assistance than nationals of the hosting State and than third-country migrants. It has been showed that EU migrants on the move are rather net contributors to the budget of the hosting State and not likely to abuse social assistance.

Such surveys should be more regular and shared to the larger public to prevent any unfounded claim. And when unfounded fears are voluntarily used to deceive local population in order to restrict migration, more statistical evidence can also help. These evidence should not be left to a circle of experts but shared with a larger public to avoid any manipulation.

### **3.5. Make a clear distinction between abusers of rights and normal users of rights**

Member States are allowed to refuse, terminate or withdraw any right conferred by Directive 2004/38/EC in case of abuse of rights or fraud (Article 35). This provision should be used against any abuser or fraudster as it breaks the image of European mobility, since it reflects dishonest practises (Morin-Chartier, 2017). But it should not be used against EU citizens who are just using their fundamental right to move. States' practises have shown that non-self-sufficient EU mobile citizens who have not applied for social assistance have been accused of becoming an unreasonable burden. However, only receipt of social assistance benefits can be considered relevant to determining whether the person concerned is a burden on the social assistance system (European Commission, 2009). The individual approach (case by case) is very important in presumed cases of abuse of rights. It guarantees to the migrant the examination of his/her personal circumstances. For example, the integration link between the migrant and its hosting State has to be examined in concreto for economically inactive EU citizen who stays between three months and five years (Carlier, 2013).

### **3.6. Keeping in mind the spirit of Directive 2004/38/EC**

When implementing Directive 2004/38/EC, national administrations often forget the spirit, the light of Directive 2004/38/EC which should be considered as a priority. Indeed, EU intra-mobility aims to facilitate free-movement. Consequently derogations from that principle must be interpreted strictly (C-33/07 Jipa-para 23). Of course, the right of freedom of movement is not unconditional. But as far as the limits provided for in Directive 2004/38/EC (threat to public policy, public security, public health, abuse of law and fraud, unreasonable burden, non-respect of entry and residence conditions) are not touched, the spirit of the Directive should be privileged. This means that when a Member State has to examine the personal situation of a non-self-sufficient EU migrant, checking its financial resources according to the criteria of the hosting country, it should keep in mind economic imbalances between Member States. A Romanian or a Bulgarian citizen is able to live with a much lower amount of money than a French or German citizen. Similarly, the most severe sanction, the expulsion of the EU migrant should be used exceptionnally and should not concern EU mobile citizens who are neither a threat neither an unreasonable burden for the hosting State. Indeed, deportation is potentially harmful to the status of EU citizenship and an indication of its structural weakness (Kochenov, 2013).

## **4. CONCLUSION**

Freedom of movement of EU citizens is one of the foundations of the EU. This right has been built for nearly 70 years and is not yet completed. Since a decade, it is under pressure and it is experiencing a reverse progression. This shows clearly that this fundamental right is not granted as the membership to the EU illustrated by the Brexit. Despite the requirements for less integration, less rights for the movers, only more integration, more solidarity and more consensus can save the European project. Legal certainty is also essential as it prevents abuses from Member States and from EU mobile citizens.

**ACKNOWLEDGEMENT:** *This article has been supported by the Czech project PROGRES Q04 so called »Právo v měnicím se světě« from Charles University, Czech Republic.*

## LITERATURE:

1. Carlier, Jean-Yves. (2013). *Opérateur économique, citoyen, 'personne' : quelle liberté choisir pour la protection de ses droits ?* Et pluribus unum. In: Edouard Dubout, Alexandre Maitrot de la Motte (dir.), *L'unité des libertés de circulation In varietate concordia*, Bruylant : Bruxelles 2013, p. 233-249.
2. Carrera, S. (2014). "The Framing of the Roma as Abnormal EU Citizens: Assessing European Politics on Roma Evictions and Expulsions in France" in *The Reconceptualization of European Union Citizenship*. Edited by Guild. Leiden: Brill Nijhoff (2014), 33–63.
3. Court of Justice of the European Union. *Judgment of the Court of 20 September 2001. Rudy Grzelczyk v Centre public d'aide sociale d'Ottignies-Louvain-la-Neuve*. Retrieved 3.12.2018 from <https://eur-lex.europa.eu/legal-content/EN/TXT/?qid=1543848374393&uri=CELEX:61999CJ0184>.
4. Court of Justice of the European Union. *Judgment of the Court of 12 May 1998. María Martínez Sala v Freistaat Bayern*. Retrieved 3.12.2018 from <https://eur-lex.europa.eu/legal-content/EN/TXT/?uri=CELEX:61996CJ0085>.
5. Court of Justice of the European Union. *Judgment of the Court of 28 October 1975. Roland Rutili v Ministre de l'intérieur*. Retrieved 3.12.2018 from <https://eur-lex.europa.eu/legal-content/EN/TXT/?uri=CELEX%3A61975CJ0036>
7. D'Ambrosio, Lucas. (2011). *When immigration is a crime*. Retrieved 3.12.2018 from <https://booksandideas.net/When-Immigration-Is-a-Crime.html>.
8. Eur-lex. (2004). *Directive 2004/38/EC of the European Parliament and of the Council of 29 April 2004 on the right of citizens of the Union and their family members to move and reside freely within the territory of the Member States amending Regulation (EEC) No 1612/68 and repealing Directives 64/221/EEC, 68/360/EEC, 72/194/EEC, 73/148/EEC, 75/34/EEC, 75/35/EEC, 90/364/EEC, 90/365/EEC and 93/96/EEC (Text with EEA relevance)*. Retrieved 3.12.2018 from <https://eur-lex.europa.eu/legal-content/EN/TXT/?uri=celex%3A32004L0038>
9. European Commission, DG Employment, Social affairs and Inclusion. (2013). *A fact finding analysis on the impact on the Member States' social security systems of the entitlements of non-active intra-EU migrants to special non-contributory cash benefits and healthcare granted on the basis of residence*. Retrieved 3.12.2018 from <file:///C:/Users/User/Downloads/20131212%20GHK%20study%20web.pdf>.
10. European Commission. (2009). *Communication from the Commission to the European Parliament and the Council on guidance for better transposition and application of Directive 2004/38/EC on the right of citizens of the Union and their family members to move and reside freely within the territory of the Member States /\* COM/2009/0313 final \*/*. Retrieved 3.12.2018 from <https://eur-lex.europa.eu/legal-content/EN/TXT/?uri=CELEX:52009DC0313>.
11. European Commission. (2017). *EU Citizenship report 2017. Strengthening Citizens' Rights in a Union of Democratic Change*. Retrieved 3.12.2018 from <file:///C:/Users/User/Downloads/CitizenshipReport-Summary-EN.pdf>.
12. European Commission. (2017). *Press release: Roma inclusion: More effort needed to improve access to schooling and employment*. Retrieved 3.12.2018 from [http://europa.eu/rapid/press-release\\_IP-17-2961\\_en.htm](http://europa.eu/rapid/press-release_IP-17-2961_en.htm).
13. European Parliament, European Parliamentary Research Service. (2014). *Freedom of movement and residence of EU citizens- Access to social benefits*. Retrieved 3.12.2018 from [http://www.europarl.europa.eu/RegData/bibliotheque/briefing/2014/140808/LDM\\_BRI\(2014\)140808\\_REV1\\_EN.pdf](http://www.europarl.europa.eu/RegData/bibliotheque/briefing/2014/140808/LDM_BRI(2014)140808_REV1_EN.pdf).



14. Federal Minister of the Interior of Austria, the Federal Minister of the Interior of Germany, the Minister for Immigration of the Netherlands and the Secretary of State for the Home Department of United Kingdom. (2013). *Joint letter to Commissioners Reding, Malmstrom and Andor*. Retrieved 3.12.2018 from [http://docs.dpaq.de/3604-130415\\_letter\\_to\\_presidency\\_final\\_1\\_2.pdf](http://docs.dpaq.de/3604-130415_letter_to_presidency_final_1_2.pdf).
15. Fernandez, Sonia. (2016). *Access to social benefits for EU mobile citizens: "tourism" or myth?* Retrieved 3.12.2018 from <http://www.institutdelors.eu/wp-content/uploads/2018/01/socialbenefitseumobilecitizens-fernandes-jdi-june16.pdf?pdf=ok>.
16. Guild, Elspeth, Carrera, Sergio, Eisele, Katharina. (2013). *Social benefits and migration, A contested relationship and a policy challenge in the EU*. Retrieved 3.12.2018 from <https://www.ceps.eu/system/files/Migration%20and%20Social%20Benefits-1.pdf>.
17. Guénard, Florent. (2011). *European citizenship on the March*. Retrieved 3.11.2018 from <https://booksandideas.net/The-Foundations-of-a-European.html>.
18. Hailbronner, K. (2006). *Union citizenship and social rights*. In Carlier, J.Y., Guild, E. (Eds.). *The future of free movement of persons in the EU*.
19. Lafleur, J.M, Stanek, M. (2017). *"Five lessons From the Migration of EU Citizens in Times of Crisis in South-North Migration of EU Citizens in Times of Crisis"*. Edited by Springer.
20. Lhernould J. P. (2011). « *Prestations sociales : les Roms roumains et bulgares ne sont pas des sous-citoyens de l'Union européenne* ». In *Abécédaire des discriminations, Six ans de délibération de la Halde*. Edited by Paris: La Documentation française (2011), 115–119.
21. Le Monde. (2016). *En Allemagne, non au « tourisme social »*. Retrieved 3.12.2018 from [https://www.lemonde.fr/europe/article/2016/10/15/en-allemande-non-au-tourisme-social\\_5014319\\_3214.html](https://www.lemonde.fr/europe/article/2016/10/15/en-allemande-non-au-tourisme-social_5014319_3214.html)
22. Morin-Cartier, E. (2017). « *Quel impact de la liberté de circulation sur les systèmes de protection sociale au sein de l'Union européenne?* ». Retrieved 3.12.2018 from <https://www.robert-schuman.eu/fr/doc/questions-d-europe/qe-429-fr.pdf>.
23. Phoa, Pauline. (2015). *EU citizenship: reality or fiction? A Law & Literature approach to EU*. Retrieved 3.12.2018 from <http://beucitizen.eu/wp-content/uploads/PPHOA-Zagreb-citizenship-fact-or-fiction-August-2015-revised.pdf>.
24. Sorensen, Catharina. (2014). *Some solutions for the EU Social benefit debate*. Retrieved 3.12.2018 from <https://euobserver.com/opinion/124536>.

## A COST ANALYSIS OF ALTERNATIVE THERAPEUTIC OPTIONS FOR CHRONIC KIDNEY DISEASE: A CASE STUDY

**Sara Pinto da Silva**

*ADI Higiene - InovGrupo  
s.silva@inovgrupo.com*

**Anabela Martins Silva**

*School of Economics and Management of University of Minho, Braga, Portugal  
anabela@eeg.uminho.pt*

**Amelia Ferreira da Silva**

*CEOS of Polytechnic of Porto,  
Porto Accounting and Business School, Porto, Portugal  
acfs@iscap.ipp.pt*

**Humberto Ribeiro**

*GOVCOPP, ESTGA, University of Aveiro, Aveiro, Portugal  
hnr@ua.pt*

### **ABSTRACT**

*Chronic kidney disease is a highly complex problem. Some types of chronic kidney patients have two therapeutic alternatives: hemodialysis (hospital); or peritoneal dialysis (home). The clinical efficacy expected from each therapeutic is virtually the same. However, the economic costs and the quality of life are different. In face of the increasing expenditure of the National Healthcare System with chronic kidney disease, together with an environment of economic and financial crisis making the management function a hard challenge, health organizations and health professionals are called for real integration of clinical information and economic information in their decision-making. A longitudinal study in a central teaching hospital was designed. During the research period, it was studied which of the therapies currently provided by the hospital for chronic kidney disease is economically less costly. A deep understanding of this issue may enable policymakers and hospital top managers to implement better management models to create an organizational context within which doctors, managers and accountants may work together and share common goals toward the organizational mission.*

**Keywords:** *Management, Management Accounting, Healthcare Management, Hemodialysis, New Professionalism, Peritoneal Dialysis*

### **1. INTRODUCTION**

In a context of financial and economic crisis, such as the one Portugal is undergoing since 2008, the growth of health expenditures is a severe problem, both at the managerial, economic and political levels. So, it is imperious to rethink the management model of healthcare organizations, in order to ensure that the best practices are provided to citizens at the lowest possible cost. The perceived incomparability, immeasurability and uncontrollability of medical practice precluded the application of cost accounting to the clinical functions of hospitals (Gebreiter, 2015). Nonetheless, the standardization of medical routines and the work introduced by Evidence Based Medicine stimulates the design of cost accounting models for decision making and management control in healthcare organizations. The 2010 Global Burden of Disease study suggests that the number of deaths where chronic kidney disease (CKD) is the International Classification of Diseases (ICD) underlying cause of death increased by 82% from 1990 to 2010.

In 1990, chronic kidney disease was ranked 27th in the list of causes of the total number of global deaths but rose to the 18th place in 2010 (Lozano et al., 2012). Based on a case of a longitudinal study conducted in a Portuguese central teaching hospital, this paper aimed to examine which of the therapies currently provided by the public healthcare system for chronic kidney disease – Hemodialysis (HD) versus Peritoneal Dialysis (PD) – is economically less costly. The final intent is to provide clinical decision makers with relevant economic information, so that clinical decision can be more informed. The paper is structured in the following sections: (i) a global dimension and perspectives of CKD; (ii) the methodology applied and the identification and description of the case study; (iii) an analysis of the costs of dialysis programs; and finally, (iv) main conclusions and research limitations.

## **2. GLOBAL DIMENSION AND PERSPECTIVES OF CKD**

Chronic kidney disease is a progressive disease characterized by an increasing inability of the kidneys to filter waste products, excess water, and other impurities out of the blood. When this disease reaches the point that kidneys do not support the body, this ultimately will require dialysis (a medical procedure) to clean the blood. Hill *et al.* (2016) defined CRD as a reduced glomerular filtration rate, increased urinary albumin excretion. In the 2013 Global Burden of Disease report, CKD is pointed as the non-communicable disease with the biggest growth over the last 23 years, as a cause of death. Based on the 2013 Global Burden of Disease, Jager and Fraser (2017, p. 123) affirm that “global deaths due to all-cause CKD in 1990 were 409 000 (363 844 - 433 380) compared with 956 000 (812 896 - 1 034 491) in 2013”. Using more recent data from the 2015 Global Burden of Disease Study, Neuen, Chadban, Demasio, Johnson, and Perkovic (2017, p. 1) sustain that “kidney disease was the 12th most common cause of death, accounting for 1.1 million deaths worldwide. Overall CKD mortality has increased by 31.7% over the last 10 years, making it one of the fastest rising major causes of death, alongside diabetes and dementia. In the same study, CKD ranked as the 17th leading cause of global years lost of life, an 18.4% increase since 2005, and the third largest increase of any major cause of death”. In such a context, the need for a simple definition and classification of kidney disease in the international arena was considered of great importance by KDIGO (Kidney Disease: Improving Global Outcomes) for the development and implementation of clinical practice guidelines. This organization conducted a survey and sponsored an International Controversies Conference on “Definition and Classification of Chronic Kidney Disease in Adults”, held in Amsterdam in 2004, to develop global consensus for the adoption of a simple definition and classification system. According to Levey *et al.* (2005, p. 2092), “it is challenging for health care providers from diverse geographic regions with varying political, cultural, and economic systems to agree with all the aspects of a definition and classification for CKD”. Nonetheless, Levey *et al.* (2005, p. 2092) comment that conference attendees expressed widespread agreement about the following definition and classification of CKD:

- a) The K/DOQI definition of CKD was that it could be done by kidney damage or by level of the GFR, and was accepted with the classification shown in Table 1;
- b) Classification of CKD could be done according to severity, diagnosis, treatment, and prognosis (see Table 2).

*Table following on the next page*

*Table 1: Criteria for the definition of chronic kidney disease*

Kidney damage for  $\geq 3$  months, as defined by structural or functional abnormalities of the kidney, with or without decreased GFR, that can lead to decreased GFR, manifested by either:  
 Pathologic abnormalities; or  
 Markers of kidney damage, including abnormalities in the composition of the blood or urine, or abnormalities in imaging tests  
 GFR  $< 60$  ml/min/1.73 m<sup>2</sup> for  $\geq 3$  months, with or without kidney damage

GFR is the glomerular filtration rate. Modified and reprinted with permission by the National Kidney Foundation (2002 by referenced Levey *et al.*, 2005, p. 2093)

*Source: National Kidney Foundation (2002, referenced by Levey et al., 2005, p. 2093).*

*Table 2: Classification of chronic kidney disease (CKD)*

Stage	Description	Classification by severity		Classification by treatment
		GFR	Related terms	
1	Kidney damage with normal or $\uparrow$ GFR	$\geq 90$	Albuminuria, proteinuria, hematuria	T if kidney transplant recipient
2	Kidney damage with mild $\downarrow$ GFR	60–89	Albuminuria, proteinuria, hematuria	
3	Moderate $\downarrow$ GFR	30–59	Chronic renal insufficiency, early renal insufficiency	
4	Severe $\downarrow$ GFR	15–29	Chronic renal insufficiency, late renal insufficiency, pre-ESRD	
5	Kidney failure	$< 15$ (or dialysis)	Renal failure, uremia, end-stage renal disease	
				D if dialysis (hemodialysis, peritoneal dialysis)

Abbreviations are:

GFR, Glomerular Filtration Rate;

ESRD, End-Stage Renal Disease.

Related terms for CKD stages 3 to 5 do not have specific definitions, except ESRD

*Source: Levey et al. (2005, p. 2094).*

According to Levey et al. (2005, p. 2094), “classification systems can be simple or complex. The choice of a classification system depends on answers to several questions: (i) To whom is the classification system addressed? (ii) Can we build a system that is useful to most clinicians, with additional complexity that is useful to some? (iii) Can the classification system be linked to “Action Plans”? An action plan should be evidence-based, but modifiable based on considerations for different populations, and individualized based on patient circumstances”. Hill et al. (2016) developed a comprehensive meta-analysis of observational studies and confirmed that CKD has a high prevalence. However, Glasscock, Warnock, and Delanaye (2017, p. 104) affirm that “estimates of CKD prevalence vary widely, both within and between countries”. This point of view is shared by Schieppati and Remuzzi (2005), who argue that “there is a wide variation in prevalence rate, expressed as number of patients per million population, among countries”. Additionally, as stated by Jha et al. (2013, p. 10), “chronic kidney disease is a global public health issue with different features to take into account in different parts of the world”. Moreover, “there is a strong relationship between prevalence rate and per capita income, and governmental infrastructure, which can influence both the availability and quality of dialysis and transplantation services” (Schieppati and Remuzzi, 2005, p. 8). According to country profiles available in the IHME – Institute for Health Metrics and Evaluation’s website – an overview of findings from the Global Burden of Disease –, in Portugal, CKD is in the top 10 causes of death in 2017 and raised from the 10<sup>th</sup> to the 9<sup>th</sup> position between 2007 and 2017.

In Portugal, the integrated management of chronic kidney disease has completely redefined the way of financing and providing care to these patients. It includes the establishment of a comprehensive price, considering (i) the total cost of a patient for a specific period; (ii) the expected quality and results; (iii) a direct connection between the payment and the care services provided; and (iv) monitoring and control. The following clinical options are available: Hemodialysis (HD), Peritoneal Dialysis (PD), Renal Transplant, and no treatment. We are going to compare the two first options in terms of costs and quality of life. We assume that both treatments are clinically effective.

### 3. METHODOLOGY

In terms of the methodology used in this study, we followed the qualitative research paradigm. This case study is an in-depth empirical research in the real context of a Nephrology Unit, of a Portuguese, public, teaching, and Central Hospital. In 2014, one of the researchers spent six months (five days a week) in the hospital for data collections, interviews, observations and data analysis. Data was collected through direct observation, document analysis (information/data from the various departments and hospital services), and informal interviews with doctors, nurses, technicians, clinical directors and administrative staff.

#### 3.1. Sample

At the time of the study, the Nephrology Unit was treating about forty (40) patients with Hemodialysis (HD) and eighty-seven (87) with peritoneal dialysis (it was the most representative program in Portugal). Thus, our sample consists of one hundred and thirty-one patients. Table 3 presents its demographic characteristics:

*Table 3: Demographic characteristics of the sample*

<b>HD Hemodialysis</b>	<b>DP Peritoneal Dialysis:</b>
44 patients	87 patients
33,6% of total chronic patient	66,67% of total chronic patient
Sex:	Sex:
<ul style="list-style-type: none"> <li>▪ Male: 50%</li> <li>▪ Female: 50%</li> </ul>	<ul style="list-style-type: none"> <li>▪ Male: 44,8%</li> <li>▪ Female: 52,2%</li> </ul>
Age	Age
<ul style="list-style-type: none"> <li>▪ Less than 35 2.3%</li> <li>▪ Between 36 and 49: 27.3%</li> <li>▪ Between 50 and 64: 31.8%</li> <li>▪ Between 65 and 79: 25%</li> <li>▪ Exceeding 80: 13.6%</li> </ul>	<ul style="list-style-type: none"> <li>▪ Less than 35 2.3%</li> <li>▪ Between 36 and 49: 18.4%</li> <li>▪ Between 50 and 64: 35.6%</li> <li>▪ Between 65 and 79: 21.8%</li> <li>▪ Exceeding 80: 2.3%</li> </ul>

#### 3.2. Clinical Process

Medical professionals tend to argue that each patient is a special case. So, clinical work became difficult to standardize, measure and control. However, clinical protocols and Evidence-Based Medicine open the doors to the standardization of medical work, making cost accounting easier, although still complex. Thus, we tried to standardize clinical procedures regarding CKD. After a deep analysis of interviews, we defined the alternative trajectory of patients as depicted in Figure 1.

*Figure following on the next page*

Figure 1: Alternative trajectory of patients with CKD

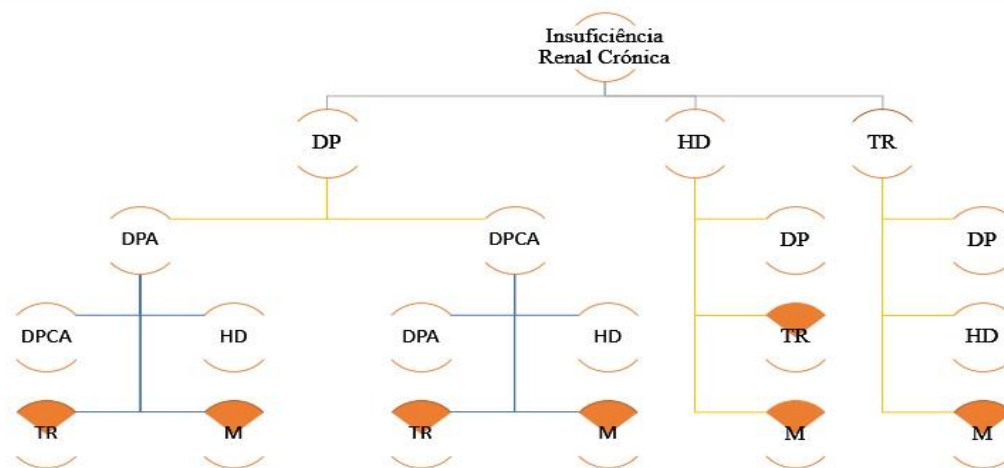

**Subtitle:**

HD - Hemodialysis

DP - Peritoneal Dialysis

TR - Renal Transplantation

M - Death

DPA - automatic DP

DPCA - DP still ambulatory

The death and renal transplantation are indicated in the figure because, in probabilistic terms, are events that should be considered, although these interactions are not included in the project analysis. It was very difficult to design this scheme because it is a simplification of reality. However, it was essential for the economic analysis. It is important to say that the Director of the DP Unit acknowledged the usefulness and relevance of the flowchart drawn. In fact, this flowchart summarizes the work processes involved in the various therapeutic responses. When these processes become intelligible to the technical management of the area, it is possible to create a communication platform between physicians and other healthcare professionals and accountants.

**3.3. Cost classification**

The normalization of cost accounting among Portuguese public hospitals started in 1996 with the application of Plan of Cost Accounting. It was a top-down and gross costing method, structured according to the French method of homogeneous sections. Although it was a mandatory model, each hospital could create its own management accounting system. According to Ferreira da Silva and Cyganska (2017, p. 79), “the aim of this system is essentially the budget control of clinical units, clinical departments and hospital as a unit. Once the cost information is aggregated by a central governmental body (ACSS), it facilitates the central control of the hospitals’ budget at a higher level”. These authors argue that the top-down and gross costing methods are used for cost calculation, although some hospitals use simultaneously the microcosting methodology in some clinical units and only concerning patient direct costs, such as drugs, clinical material and complementary diagnosis and therapeutic means. Since the demands for health care system resources arise from treating a patient’s medical condition, we assume the patient as the unit of analysis for costing purposes. So, using patients as the cost unit, and based on accounting data and interviews, we identified the direct and indirect cost related to CKD patients, as it is described in Table 4.

Table following on the next page

*Table 4: Main components of direct and indirect cost of CKD patient*

<b>Direct expenses</b>	<b>Indirect expenses</b>
Medications	Clinical sessions General support Administrative support
Transport	
Supplementary diagnostic and therapeutic	
Bags of dialysis (DPA kit / DPCA)	
Human Resources	
Consumable: clinical, accommodation administrative materials	
Equipment, maintenance and other external services	

To avoid accounting bias, we decided not to treat indirect costs. These costs are assessed according to a top-down method, as we pointed out before. In our analysis, all the structural costs at the institutional and unit levels are classified as indirect costs and, consequently, these costs are not allocated to patients. Since January 2012, public hospitals are paid a comprehensive amount of € 67.156 per patient per day (Order no. 10569/2011) by each patient they provide health care for chronic ambulatory hemodialysis and peritoneal dialysis program. These value aims to cover direct costs, such as drugs and complementary means of diagnosis. To provide a scheme of comparison between the actual costs and those established in the comprehensive price and protocol costs, we defined a model that makes it possible to calculate the costs for each of the most frequent scenarios associated with the care of patients on hemodialysis and peritoneal dialysis, as described before in Figure 1.

#### **4. RESULTS**

The concerns about the growing costs of public healthcare services have been leading to significant changes in health policies, with crucial repercussions on the system's response to chronic kidney disease. To the best of the authors' knowledge, studies about economic behavior and performance of national dialysis units (hospitals or clinics) are scarce. There is a study conducted by an international consulting company, in 2010, and commissioned by the Central Administration of Health Systems. This study pointed out important arguments that were used to diminish the practices of Peritoneal Dialysis. However, it was severely criticized by the Physicians College of Nephrologist Specialty. In Portuguese public hospitals the cost accounting models are mainly based on top-down gross costing, i.e., cost components are defined at a highly aggregated level. In this section, we propose an approximation to a bottom-up microcosting model, where all relevant cost components are defined at the most detailed level. We began with the differentiation of Direct and Indirect costs regarding CKD patients. Data about direct costs and clinical processes were extracted from the hospital's cost accounting and management control system and were treated in an annual base, as exhibited in Table 5.

*Table following on the next page*

*Table 5: Analysis and comparison of annual DP and HD spending*

	<b>DP Annual Cost</b>	<b>%</b>	<b>HD Annual cost</b>	<b>%</b>
<b>Medication</b>	203.537,87 €	12.8%	80.192,22 €	7.1%
<b>MCD</b>	16.971,25 €	1.1%	44.304,04 €	3.9%
<b>Kit treatment</b>	1.251.616,20 €	78.5%	- €	0.0%
<b>Clinical material</b>	4.342,68 €	0.3%	636.530,15 €	56.5%
<b>Hospitality Material</b>	545,23 €	0.0%	2.089,63 €	0.2%
<b>Administrative Material</b>	870,09 €	0.1%	4.930,52 €	0.4%
<b>Maintenance</b>	- €	0.0%	3.851,00 €	0.3%
<b>Overheads</b>	- €	0.0%	66.060,00 €	5.9%
<b>HR – Doctors</b>	58.599,95 €	3.7%	91.741,610 €	8.1%
<b>HR – Nurses</b>	44.020,01 €	2.8%	70.432,019 €	6.3%
<b>HR – Technical assistance</b>	4.246,31 €	0.3%	8.492,610 €	0.8%
<b>HR – Operational assistance</b>	1.453,89 €	0.1%	23.262,281 €	2.1%
<b>Transport</b>	8.069,96 €	0.5%	94.003,76 €	8.3%
<b>Total of direct costs</b>	1.594.273,44 €	100.0%	1.125.889,84 €	100.0%
<b>Indirect costs</b>	18.017,63€		162.158,69€	
<b>Total Costs</b>	1.612.291,07€		1.288.048,54€	

The list presented in the table above includes:

- Medication (at the national level this is the heaviest and rising expenditure in recent years): Patients with CKD have access to essential medication for free, since it is prescribed by the hospital doctor or supplied by the hospital pharmacy. In both programs, it was necessary to safeguard the non-inclusion of medicines in contexts such as urgency episodes, hospitalization and other sporadic situations. If we consider the sporadic situations (abnormal to the program), the costs increased by 38% in PD and 10% in HD (data collected from the hospital pharmaceutical service).
- Complementary means of diagnosis: Regarding PD, we excluded the exams and analyzes of the active patients in the context of urgency or hospitalization, and exams and analyzes required by other specialties of the hospital. In HD, the costs related to the Unit's protocol were considered.
- DP bags (kit) (DP only): It includes handbags, delivery service and nursing support. The practice of prices is differentiated by the subcontracted companies. The contract is based on the number of days of treatment (regardless of the number of daily exchanges).
- Consumables: Clinical, Hospitality and Administrative consumables are difficult to access because HD and DP share the same store of clinical and consumable materials. We considered that 15% of these costs were related to PD and the remaining 85% to HD.
- Human Resources: The costs with Doctors, Nurses, and Administrative and Clinical Assistance were calculated on the basis of the number of professionals (equivalent) working in the service, their annual costs and the hours allocated to each professional group – reviewed with the Director of Service.
- Equipment, maintenance and provision of external services (HD only). During the year under review, there was no acquisition of new equipment and all equipment existent and necessary to the programs are already fully amortized (as of 2013). The HD machines were purchased under a consumer agreement, having no acquisition value other than the consumables already considered in the MCC.
- Transport: Costs with patient's transport are reimbursed by the Regional Health Administration. The reimbursement is made to the hospital under the following conditions:
  - total reimbursement of the expense if the patient has economic insufficiency and a disability greater than 60% (chronic renal patient);
  - partial reimbursement of the expense if the patient has a disability greater than 60% and must go to hospital at least eight times



per month. Once only the patients in HD meet this last requirement, to avoid discrimination, the Nephrology Department submits, through the transport platform (automatically), a requirement for PD daily transport, although it does not happen at all. This incongruence makes it difficult to have reliable information; thus, we follow some assumptions based on interview records: - one patient in DP travels, on average, 37.6 km; - one patient in HD travels, on average, 16.1 km. Normally, patients in HD live closer to a dialysis center.

After gathering all costs, and seeking to get a more in-depth analysis, we used the same measure of time in both programs (number of days of treatment for each patient). The calculation of the Daily Cost per Patient facilitated the comparison between alternatives and with the comprehensive price. Table 5 shows the analysis and comparison of DP and HD spending for DP vs HD.

*Table 6: Analysis and comparison of daily DP and HD spending*

	<b>Cost DP/ day</b>	<b>Cost HD/day</b>
<b>Medication</b>	8,04 €	5,51 €
<b>MCDT</b>	0,67 €	3,04 €
<b>Bags</b>	49,45 €	- €
<b>MCC</b>	0,17 €	43,71 €
<b>MCH</b>	0,02 €	0,14 €
<b>MCA</b>	0,03 €	0,34 €
<b>Maintenance</b>	- €	0,26 €
<b>FSE</b>	- €	4,54 €
<b>RH – Doctors</b>	2,32 €	6,30 €
<b>RH – Nurse</b>	1,74 €	4,84 €
<b>RH – Technical assistance</b>	0,17 €	0,58 €
<b>RH – Op. Assist.</b>	0,06 €	1,60 €
<b>Transport</b>	62,67 €	70,86 €
<b>Total</b>	0,32 €	6,45 €
<b>Indirect costs</b>	62,99 €	77,31 €
<b>Total costs</b>	0,71 €	11,13 €
<b>Medication</b>	63,70 €	88,45 €

As we can observe, PD is less costly. The program involves less investment and it is more flexible to changes in demand. In every moment, we assume that PD has equal clinical efficacy to HD. This is the summary of the cost per day per patient. In this study, a proposal was made to the hospital to develop a tool that can daily record the cost per patient. Although acknowledging the limitations of the model, namely the impossibility of contemplating all possible clinical situations, the model was designed to encompass a wide range of situations and to safeguard some exceptions.

## 5. CONCLUSION

Healthcare economic and financial sustainability is a real problem that Portuguese society is facing. Management accounting in healthcare is particularly difficult. Indeed, any attempt to measure costs in healthcare organizations faces huge difficulties:

Many of these problems are the result of a huge measurement gap: only a very few providers today—physicians, clinics, and hospitals—have valid measures of the outcomes they achieve or the costs they incur to treat individual patients for specific medical conditions. The lack of valid outcome information is partly a consequence of the fragmented way in which health care is delivered, with each provider entity responsible for only a component of the patient's complete care experience. But health care is a more complex setting for measuring outcomes than are manufacturing and most other service industries, which may explain why providers

default to input and process metrics rather than patients' outcome metrics (Kaplan & Witkowski, 2014, p. 366). Compared to HD, PD has currently much more favorable conditions to increase significantly and consistently in the short-term public service. Our study concluded that PD: (i) is less costly; (ii) involves less investment; and (iii) is more flexible. Moreover, it promotes a more responsive health system and the clinical efficacy is identical to that of HD. However, we should be cautious in extrapolating results. Firstly because to make comparisons only direct spending should be used; secondly because we need cost information of a more extended period; thirdly because we need to study other hospital structures; and finally because there are some types of patients for whom PD is not too difficult. Moreover, we should be aware that each clinical unit is a different reality, both at the clinical, economic, cultural and sociological levels. With this study, we hope to contribute to the optimization of clinical and economic management of the provision of peritoneal dialysis in the Hospital (CHP). Overall, we hope to contribute to the dialogue between two areas of knowledge – management and medicine – that are essential to improve hospitals' management. Further research should consider extending this study to similar clinical units of the National Health System and portrait a national reality of the costs involved in the CDR therapeutic. Without this national perspective, it is not possible to take structural decisions based on local cost and management accounting systems.

#### **LITERATURE:**

1. Ferreira da Silva, A. C. & Cyganska, M. (2017). Comparison of Polish and Portuguese hospital cost accounting methods. *Motricidade*, 12(4), 73-82.
2. Gebreiter, F. (2015). "Comparing the incomparable": Hospital costing and the art of medicine in post-war Britain. *The British Accounting Review*, 48(2), 257-268.
3. Glasscock, R. J., Warnock, D. G., & Delanaye, P. (2017). The global burden of chronic kidney disease: Estimates, variability and pitfalls. *Nature Reviews Nephrology*, 13(2), 104-114.
4. Hill, N. R., Fatoba, S. T., Oke, J. L., Hirst, J. A., O'Callaghan, C. A., Lasserson, D. S., & Hobbs, F. R. (2016). Global prevalence of chronic kidney disease – A systematic review and meta-analysis. *PloS one*, 11(7), e0158765.
5. Jager, K. J., & Fraser, S. D. (2017). The ascending rank of chronic kidney disease in the global burden of disease study. *Nephrology Dialysis Transplantation*, 32(suppl\_2), ii121-ii128.
6. Jha, V., Garcia-Garcia, G., Iseki, K., Li, Z., Naicker, S., Plattner, B., Saran, R., Wang, A. Y., & Yang, C. W. (2013). Chronic kidney disease: global dimension and perspectives. *The Lancet*, 382(9888), 260-272.
7. Kaplan, R. S., & Witkowski, M. L. (2014). Better accounting transforms health care delivery. *Accounting Horizons*, 28(2), 365-383.
8. Levey, A. S., Eckardt, K. U., Tsukamoto, Y., Levin, A., Coresh, J., Rossert, J., Zeeuw, D.; Hostetter, T. H., Lameire, N., Eknoyan, G. & Willis, K. (2005). Definition and classification of chronic kidney disease: A position statement from Kidney Disease: Improving Global Outcomes (KDIGO). *Kidney International*, 67(6), 2089-2100.
9. Lozano, R., Naghavi, M., Foreman, K., Lim, S., Shibuya, K., Aboyans, V., ... & AlMazroa, M. A. (2012). Global and regional mortality from 235 causes of death for 20 age groups in 1990 and 2010: A systematic analysis for the Global Burden of Disease Study 2010. *The Lancet*, 380(9859), 2095-2128.
10. Neuen, B. L., Chadban, S. J., Demaio, A. R., Johnson, D. W., & Perkovic, V. (2017). Chronic kidney disease and the global NCDs agenda. *BMJ Global Health*, 2, e000380.
11. Schieppati, A., & Remuzzi, G. (2005). Chronic renal diseases as a public health problem: Epidemiology, social, and economic implications. *Kidney International*, 68, S7-S10.

# PRICE AS THE STRONGEST MARKETING MIX TOOL IN THE BUYING PROCESS FROM A CONSUMER PERSPECTIVE

**Jaroslava Gburova**

*University of Prešov in Prešov, Faculty of Management, Slovakia  
jaroslava.gburova@unipo.sk*

**Radovan Bacik**

*University of Prešov in Prešov, Faculty of Management, Slovakia  
radovan.bacik@unipo.sk*

## **ABSTRACT**

*Price and pricing policy are an important part of the buying process of both Slovak and foreign consumers. We meet with the price every day when buying goods and services. Too low prices for products can discourage consumers, as well as too high prices. Price policy and prices in the buying process have a psychological effect on the current consumer. Pricing and pricing policy is the only marketing mix that generates revenue. The changing political situation of a given country reflects very strongly on the level of the prices that most closely affect the consumers and their purchasing decisions. The objective of the contribution is the theoretical processing of the studied issue in the field of prices and pricing policy as well as the analysis of the impact of prices and price policy depending on the changing political situation in the Slovak Republic from the point of view of a Slovak consumer living in the region of Eastern Slovakia.*

**Keywords:** *Price, Consumer, Price Reductions, Political Situation, Pricing Policy*

## **1. INTRODUCTION**

The current time is full of economic and political changes that have a significant impact on the consumer and his/her decision making. Every consumer is a person with his/her own opinion. There are many different factors that has an impact on consumer behaviour. Each retail chain and unit should therefore be aware of the fact that what the target audience wants to reach and focus on and try to meet in order to obtain and maintain the most satisfied consumers. Purchasing behaviour affects a large number of factors that relate to the life of the company in which the consumer has a significant role. The current situation within the Slovak Republic is influenced by European and global processes that bring many problems and situations where solutions require a responsible approach as well as solutions in the interests of both consumers and society. Everyone decides to purchase different types of products. Consumer behaviour is therefore an integral part of the everyday life of people. We all consider buyers of any goods or services to be consumers. Every retail chain and retail store that wants to attract customers should respect the fact that the consumer is a unique person with his or her own opinion that needs to be constantly adapted (Gburová, 2012; Birknerová et al., 2017). In Slovakia, especially in shops, customers make a decision based on the price. This is evidenced by the fact that there are almost no shops that offer better food. All business chains are therefore focusing on offering the cheapest goods to customer. Price is a very often used and a very effective marketing tool when the customer's purchasing power is low (Rózsa, 2009).

## **2. LITERATURE REVIEW**

Pricing policy has and still has its merit in every economy as it is part of the state's pension policy and is geared towards guiding and implementing pricing instruments. Pricing policy also includes price regulation, which means price determination or price negotiation by pricing, local or other authorities.

The formation of a price level in the transition to a market economy, as outlined by the necessary systemic measures, was justified. The general public understood it to some extent, but it should not go beyond tolerable peace, otherwise it leads to disruption of social reconciliation, wage pressure and social consequences. For this reason, there must also be control mechanisms to prevent it and to ensure that the citizen does not pay for the non-productive traders (Oláh et al., 2009). In today's market economy, we can see the influence of the pricing mechanism in every real market situation. Prices are therefore the result of market relations. In determining prices, it is appropriate to use methods that have already been tested in more advanced economies, and their use will bring profit growth, it will increase turnover and meet target groups (Štefko, 2003; Lorincová et al., 2018). Pricing takes into account specific circumstances, e.g. cost, competition or demand. The price is part of the overall marketing strategy. The price is an element of a marketing mix, which, along with other tools, should bring the company to its marketing goals. From a marketing point of view, the price must always be judged in accordance with market requirements and satisfaction of the manufacturer's (seller's) requirements. The basic requirement for the price to function as a marketing tool is the relative freedom of the manufacturer to create it (Kita et al., 2010). In the context of market developments, especially in the times of an unsatisfied market, the price of a long period was the decisive quantity that determined the overall marketing communication. The lack of financial or exchangeable resources for the vast majority of customers created a narrow space for market relations. The amount of the price in many cases was 'the decisive quality of the offer' (Jedlička, 2003). Pricing policy is the general framework in which decisions are made about prices. It provides the guidelines and principles underlying the pricing strategy being developed and implemented. The pricing policy is designed for normal market conditions, is relatively permanent and has a repetitive character. However, in contrast, the pricing strategy is a policy designed to address the specific market situation regarding specific conditions. It is only temporary and non-repetitive (Jain, 2009). The company must set the price when it launches a new product and when it puts the already introduced product in a new distribution channel and when it receives a new offer from a new customer (Kita et al., 2005; Štefko et al., 2015). A company that decides to sell for different prices in different market segments should assume that price flexibility in these segments is diverse. Buyers on a less flexible demand market will pay higher prices. The seller takes advantage of the fact that a certain segment of the market falls under less flexible demand. By demanding higher prices from some buyers, it will increase overall sales versus the situation if companies only applied one price. Such market segments must be appropriately separated. Companies should not allow purchasers from the higher section to buy at lower prices. A range of related products is a different product and price. Its basis is to determine the correct relationship to demand or cost, or both factors (Oláh et al., 2009). Reducing the prices takes a part of the profits. Reducing the prices only by 10% forces the company to sell 50% more so that the final amount of the profits remains the same. A risky 'pricing game' raises costs and thus companies can go as far as they can go to not to lose their position on the market. Instead of reducing the prices, the question is whether there is any way to increase the value of a product or service. This 'added value' means that we can 'donate' something that does not come from profits. If we do this right, it can contribute to a positive customer experience, both on the transaction itself and on the image of our company. Good experience is the key to the customer repeating the purchase, which is, on the other hand, a way for the company to profit very well (Kotler, Armstrong, 2010). The reaction of a company to changes is also dependent on market demand. On markets characterized by high production homogeneity, an enterprise must look for a way to highlight its product (Lelková, Lorincová, 2017). If it fails to do so, it is forced to adapt to changing competing businesses. On the contrary, on the market for non-homogeneous products, the company has more opportunities to respond to the price changes of competitors.

Customer response is reflected in the relationship between the price and the quantity demanded, which is indirectly proportional, i.e., the higher the price, the lower demand and vice versa. A competition can respond equally to all price changes, or a competitor will treat each change as a new challenge and react to it in line with current interests (Kotler, Keller, 2007).

### 3. METHODS AND METHODOLOGY

The objective of the research was to analyse the influence of prices and price politics, depending on the changing political situation in the Slovak Republic from the point of view of Slovak consumers living in Eastern Slovakia. Primary information was obtained by own collection. We used a questionnaire method for data collection. The obtained primary data was then processed in the Statistica statistical program. The t-test method for independent selections was used to confirm or reject the hypothesis.

H<sub>1</sub>: We assume that there are statistically significant differences in the perception of the price and political situation in the Slovak Republic among the consumers according to their gender.

### 4. SURVEY RESULTS

The sample was made up of 108 respondents from the Prešov region. The survey sample consisted of four socio-demographic characteristics of the respondents - age, gender, education and the address of the respondent. From the 108 interviewees, 26 people were in the age category of 18-20 years (24.1%), 38 respondents aged 21 - 25 years (35.2%) and 34 respondents aged 31-35 years (5.5%). The smallest group represented consumers in the age category from 36 and over (3.7%). In order to include the following demographic question, it was compulsory to obtain information about the respondent's gender. Respondents were given the opportunity to choose one of the variants of a closed question (male-female). The results are shown in Table 1.

*Table 1: Composition of research from the point of view of the gender (output of the STATISTICA 10 statistical program)*

Category	Frequency	Percent	Valid Percent	Cumulative Percent
male	30	27.8	27.8	27.8
female	78	72.2	72.2	100.00
Σ	108	100.0	100.0	

Based on the results shown in Table 1, we can see that women represent the dominant part of the respondents, 78 (72.2%) women and 30 (27.8%) men. The composition of respondents in terms of achieved education in the Prešov region shows that 38 respondents (35.2%) completed secondary education with a school leaving examination, 30 (27.8%) respondents completed first degree university education, 26 (24%) respondents completed second degree university education and 14 (13%) respondents completed third degree of university education. The objective of the following question was to find out whether or not the price of food is rising according to respondents in the following year (2019). The media is constantly talking about higher prices. For this reason, the vast majority of Slovak consumers are sceptical and do not expect any significant improvement in this area, but rather a deterioration, increasing prices of goods and services.

Table 2: Increase in basic food prices (output of the STATISTICA 10 statistical program)

Category	Frequency	Percent	Valid Percent	Cumulative Percent
Definitely yes	36	33.3	33.1	33.3
Rather yes	54	50	50.1	83.3
I do not know	14	13	13.1	96.3
Definitely no	4	3.7	3.7	100.0
Σ	108	100.0	100.0	

36 (50%, 33.3%) of the surveyed respondents expect an increase in the prices of goods and services in the Slovak Republic in 2019. 14 (13%) of respondents did not respond to the issue and 4 (3.7%) respondents do not expect an increase in basic food prices in 2019. In the following part of the paper, the data that we used to test our hypothesis are statistically processed. When testing the statistical hypothesis, firstly we are testing the so-called zero hypothesis. According to that there is no difference between the compared groups, nor between their characteristics (averages, orders). The difference found can be attributed by coincidence and it does not actually exist. The opposite of the zero hypothesis is an alternative hypothesis, it says that differences exist and are due to group differences. The basic indicator that tells us whether to reject a zero hypothesis is p (value of statistical significance, first order error, alpha error). This tells us how likely it is to reject a hypothetical hypothesis that pays. We want to minimize the probability of error, i.e. 5% ( $p = 0.05$ ) is used as the base boundary. If  $p < 0.05$ , we reject the zero hypothesis, i.e. we accept its alternative hypothesis and the conclusion is that there is a difference between the compared groups. If  $p > 0.05$  we do not reject the zero hypothesis and we assume that there is no difference between the groups. The objective of the first research problem was to find out whether there are significant differences in the perception of the price and political situation in the Slovak Republic among consumers, depending on their gender. In connection with the above-mentioned research problem, the following alternative hypothesis is tested. The hypothesis is analyzed in Table 3.

H<sub>1</sub>: We assume that there are statistically significant differences in the perception of the price and political situation in the Slovak Republic among the consumers according to their gender.

In the second comparison, we observed differences between men and women in the surveyed items. Due to the similarity with the previous issue of urban/rural differences, the t-test for independent selections was used, the results of which are presented in Table 3.

*Table following in the next page*

*Table 3: Comparing the average male and female responses  
 (output of the STATISTICA 10 statistical program)*

Question	Gender	x	SD	t	p
In your opinion, did the global financial crisis affect the prices and the price policy of goods and services in the Slovak Republic?	male	4.00	0.91	-1.153	0.252
	female	4.21	0.80		
Do you think that the prices and the price policy in the Slovak Republic are more favourable in the light of the major signs of the crisis?	male	2.20	0.85	-0.428	0.670
Do you think that the price of basic food will rise next year?	male	4.13	0.97	0.293	0.770
	female	4.08	0.86		
If the price of bread is increased by 10%, would you still buy it?	male	4.40	0.97	-0.759	0.449
	female	4.51	0.55		
Do you prefer the good price or the quality?	male	3.00	0.83	0.750	0.455
	female	2.82	1.20		
Do you think that at your purchases you receive adequate quality for a reasonable price?	male	2.40	0.72	1.422	0.158
	female	2.13	0.94		
<b>Would you prefer to buy a more expensive Slovak product than the same but cheaper product from abroad?</b>	<b>male</b>	<b>3.87</b>	<b>1.17</b>	<b>3.475</b>	<b>0.001</b>
	<b>female</b>	<b>2.90</b>	<b>1.34</b>		
Do you feel that you would pay less money for the same goods and services in a foreign country?	male	3.80	1.06	-0.434	0.665
	female	3.90	1.04		
How much money do you spend per month on food?	male	188.00	176.17	-0.863	0.390

Based on the above-described results, only minimal differences were found between the studied groups. In most of the questions, the average score for men and women was the same, statistically significant differences were recorded in two questions. Men were more likely to prefer a purchase of a more expensive Slovak product than an identical but cheaper product from abroad. Since  $P < 0.05$  was only for two questions, then in this case we can reject the alternative hypothesis  $H_1$ . Pricing policy has and still has its merit in every economy as it is part of the state's pension policy and is geared towards guiding and implementing pricing instruments. Price and pricing policy also includes price regulation, which means price determination by pricing, local or other authorities. The formation of a price level in the transition to a market economy, as outlined by the necessary systemic measures, was justified. The general public understood it to some extent, but it should not go beyond tolerable peace, otherwise it leads to disruption of social reconciliation, wage pressure and social consequences. For this reason, there must be control mechanisms to prevent it and to ensure that the citizen does not pay for non-productive traders (Oláh et al., 2009).

## 5. CONCLUSION

It is well known that most consumers perceive prices in ways that do not have anything in common with economics. According to Kita et al. (2010) the price is based on the value the product imparts to the customer. As a result, the objective of pricing policy is to create the value the customer sees. This is an undeniably subjective factor. Therefore, the company must estimate how much the customer is willing to pay, how large the turnover will be at that price, what will be the requirements for the given production capacity, etc. Choosing a price strategy may also have a political background. This is especially true for state products or those from where the state has a decisive share. In such a case, the state maintains the employment at the cost of lowering profits by setting the price level (Oláh et al., 2009). The price is undoubtedly very important to the consumer, as it is shown by the results of our survey. However, it is also

important to forget that some consumers also prefer the value they paid for. Evaluating the products will only be a natural response at the cost they spent on buying it. Consumers often make the mistake of perceiving the value of the product. The consumer has the impression that when the price is high, the value will be high as well. Research, however, points out that consumers will save, until they have gained real evidence that the value has again improved to the required level. What does it actually mean? Consumers are simply unwilling to pay horrible amounts for what is worthless to them. We believe that only those shops and retailers who provide real value, will be successful and they will be able to set a price that their "generous" consumers will be willing to pay.

**ACKNOWLEDGEMENT:** *This article is one of the partial outputs under the scientific research grant VEGA 1/0789/17 "Research of e-commerce with relation to dominant marketing practices and important characteristics of consumer behaviour while using mobile device platforms." VEGA 1/0806/16 "Research on issues of consumer behaviour of a new generation of customers with emphasis on identifying preferences and usability of mobile platforms in the process of e-commerce of the subjects localized predominantly on the Central European Market." KEGA 0033PU-4/2017 "Implementation of interpersonal skills in the context of the Psychology of business - inovatation of contents and teaching."*

#### **LITERATURE:**

1. Birknerová, Z., Frankovský, M., Zbihlejová, L., Parova, V. (2017). Gender differences in perception of advertising in the context of expectations of advertising. *Journal of Applied Economic Sciences*. 2017. (No. 6), p.1751-1758.
2. Gburová, J. (2012). *Marketingové cenové stratégie pobočiek maloobchodných reťazcov v regióne severovýchodného Slovenska*. (1<sup>st</sup> edition). Prešov: Bookman.
3. Jain, A. (2009). *Principles of Marketing*. New Delhi: V. K. India Enterprises.
4. Jedlička, M. (2003). *Marketingový strategický manažment*. (1<sup>st</sup> edition). Trnava: Magna.
5. Kita, J. et al. (2005). *Marketing*. (5<sup>st</sup> edition). Bratislava: Iura Edition.
6. Kita, J. et al. (2010). *Marketing*. (1<sup>st</sup> edition). Bratislava: Iura Edition.
7. Kotler, P., Armstrong, G. (2010). *Principles of Marketing*. (13<sup>th</sup> edition). New Jersey: Pearson Education.
8. Kotler, P., Keller, K.L. (2007). *Marketing management*. (12<sup>th</sup> edition). Praha: Grada Publishing.
9. Lelkova, A., Lorincova, T. (2017). Prediction of manipulation as a core part of social intelligence through selected personality traits in the context of business area. *International Journal of Organizational Leadership*, 2017. 6(1), p.102-108.
10. Lorincova, T., Tomkova, A., Suhanyi, L. (2018). Prediction of Selected Personality Characteristics of Businessmen in the Context of their Potential to Work with Customer. *International Journal of Organizational Leadership*. 2018. 7(1), p. 99-105.
11. Mudřík, M., Fedorko, R. (2010). Business Via Google - New Possibilities and the Future. *Management 2010: Knowledge and Management in times of crisis and ensuing development*, ISBN 978-80-555-0257-1, 21-22 October, Prešov, Slovakia, p.448-455.
12. Oláh, M. et al. (2009). *Ceny v marketingu*. (1<sup>st</sup> edition). Bratislava: Elita.
13. Rózsa, Z. (2009). *Tvorba cien v obchodnom podnikaní*. In Oláh, M. et al. (2009). *Ceny v marketingu*. (1<sup>st</sup> edition). Bratislava: Elita.
14. Štefko, R. (2003). *Akademické marketingové inštrumentárium v marketingu vysokej školy*. (1<sup>st</sup> edition). Bratislava: R.S. Royal Service.
15. Štefko, R., Kiral'ová, A., Mudřík, M. (2015). *Strategick Marketing Communication in Pilgrimage Tourism. Conference: Proceedings of the 3rd International Conference on Strategic Innovative Marketing (IC-SIM)*, ISSN 1877-0428, 01-04 September, Madrid, Spain, p.423-430.



## GENDER PAY GAP IN THE ICT SECTOR IN POLAND IN 2010-2016

**Agata Gomolka**

Jagiellonian University,  
Faculty of Management and Social Communication,  
Kraków, Poland  
agata.gomolka@doctoral.uj.edu.pl

### **ABSTRACT**

*The ICT sector, defined by the Central Statistical Office in Poland as the branch of economy dealing with information and communication technologies, is ever more important in providing equal opportunities in the access to information. It also overcomes barriers, even geographical ones<sup>1</sup>. However, the analysis of statistical data on the structure of remuneration in the Polish ICT sector illustrates that in itself there is inequality that has not been eradicated – inequality in the remuneration of women and men who provide work at the same positions. Therefore, the aim of the presented study is to analyse the existence of the phenomenon of gender pay gap at individual positions in the ICT sector in Poland (in general and with division into voivodeships) in 2010-2016. The structure of the study is as follows: the first part of the article exemplifies the overall characteristics of the ICT sector in Poland in the analysed period and presents the structure of remuneration at individual positions, with division into gender; then, an analysis of the relationship between the profession and the gender pay gap in the studied years was depicted. For this purpose, the Pearson's correlation coefficient was used, which determined the level of linear dependence between the position held and the gender pay gap. The study is completed by a summary and the most vital conclusions from previous deliberations. The literature studies on the phenomenon of gender pay gap and the analysis of statistical data made available by the Central Statistical Office in Poland and Voivodeship Statistical Offices for the years of 2010-2016 constitute the research methods.*

**Keywords:** gender pay gap, ICT sector, remuneration structure

### **1. INTRODUCTION**

The ICT (information and communication technology) sector, due to the nature of the services, is perceived as one of the key branches of the modern economy. However, in order to provide services of the highest quality, enterprises operating in this sector must employ specialists qualified in their field and provide them with conditions to acquire new knowledge on a regular basis. At the same time, this means that the remuneration of people in specialist positions will be much higher than of those who do not require such high skills and knowledge. This relationship between investing in knowledge and received remuneration was noticed already in the 20th century, among others by J. Mincer (1958; 1974). Therefore, the employee's gender should not matter, but his knowledge and whether s/he is adequately qualified to provide services at a given position. Equality in pay has also been confirmed in the most important legal aspect in Poland, i.e. the Constitution of the Republic of Poland<sup>2</sup>. Despite the existence of legal acts and regulations regarding equal pay in remuneration, the economic reality in the Polish ICT sector depicts a different reality, i.e. women and men holding the same position are not remunerated with the same amount. Therefore, the aim of this study is to recognize the relationship between the remuneration received for performing work at a given position in the

---

<sup>1</sup>Central Statistical Office in Poland (Główny Urząd Statystyczny, GUS): <http://stat.gov.pl/>.

<sup>2</sup> Pursuant to Article 33 of the Constitution of the Republic of Poland of April 2, 1997 (Journal of Laws no. 78, item 483 as amended), a women and a man in particular have equal rights to education, employment and promotion, to equal remuneration for work of equal value, for social security and for taking positions, fulfilling functions and obtaining public dignity and decorations.

ICT industry and the occurrence of the differences in the received remuneration of women and men performing similar work. The study attempted to answer the following research questions: is there a gender pay gap at every position in the ICT industry in Poland? Does the value of the gender pay gap depend on the position held? The following research hypotheses were put forward:

- H1: There is a gender pay gap at every position.
- H2: The gender pay gap is greater in positions requiring higher qualifications.

The goal and research questions determined the structure and content of the study. The first part was devoted to the presentation of the ICT industry in Poland in 2010-2016 in general and with division into administrative units, i.e. voivodeships. The second part illustrates the structure of remuneration in the analysed period with division into remuneration for women and using diagrams it depicts the disproportion in the remuneration of women and men in individual groups of profession of the Polish ICT industry. The third part was devoted to the analysis of the relationship between the profession and the gender pay gap using the Pearson's correlation coefficient. The study ends with a summary and the most important conclusions from the author's point of view.

## **2. THE ICT SECTOR IN POLAND IN 2010-2016**

The ICT services, such as software and IT consulting activities, service activities in the field of information or related activities, have been characterized in the Polish Classification of Activities as Section J – Information and Communication (Regulation of the Council of Minister of 24 December 2007 on the Polish Classification of Activities). This section in this study has been identified with the ICT industry, mainly due to the availability of data presented by the Central Statistical Office (Witkowska, Matuszewska-Janica, Kompa, 2016, p. 5). In 2010, over 95 thousand of business entities were registered in the ICT sector, with each year this number increased so that in 2016 there were already over 140 thousand entities. The average number of business entities from the analysed period has been analysed according to section J of the Polish Classification of Activities, divided into administrative units of the highest degree, i.e. the voivodeship.

*Figure following on the next page*

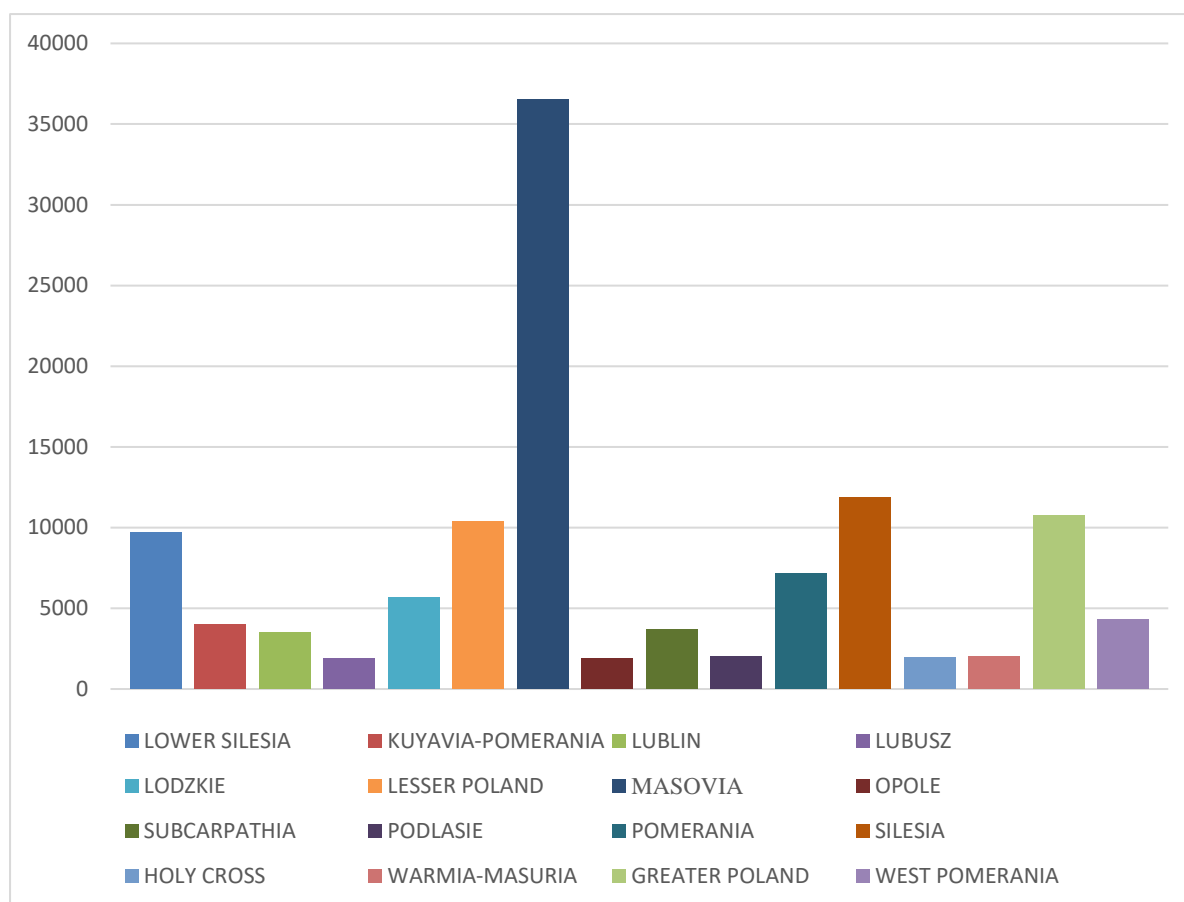

Figure 1: Average number of business entities in the ICT industry in Poland in 2010-2016 (own study based on [www.stat.gov.pl](http://www.stat.gov.pl))<sup>3</sup>.

When analysing the diagram above, it can be noticed that the greatest number of registered business entities in the analysed period was located in the Masovian voivodeship (on average over 36 thousand), on average 20 times more than in the Opole voivodeship, where the number of registered entities reached approx. 1.8 thousand entities. A large number of enterprises providing services in the ICT sector in the Masovian voivodeship is associated mainly with the capital located there (Majchrowska, Mroczek, Tokarski, 2013, pp. 70-88; Szczepaniak, Tokarski, 2018, p. 46). In the context of the Masovian voivodeship, one can also speak about the existence of the ICT industry cluster, i.e. a high level of professional activity in the ICT sector in this region (more in: Gomółka, 2018, p. 596). In the Lesser Poland, Silesian and Greater Poland voivodeships, there were over 10 thousand registered entities (respectively: 10.4 thousand, 11.9 thousand, 10.8 thousand). In other voivodeships, the number of registered entities did not exceed 10 thousand.

### 3. STRUCTURE OF REMUNERATION OF WOMEN AND MEN IN THE ICT SECTOR IN POLAND IN 2010-2016

The presentation of the pay structure of women and men in the ICT industry in Poland has been determined by the accessibility of data made available by the Central Statistical Office in Poland for the years of 2010-2016<sup>4</sup>.

<sup>3</sup> It is worth emphasizing that due to legal changes introduced from December 1, 2014 concerning the supply of the REGON register with information on entities subject to entry into the National Court Register, all legal forms of entities are not presented ([www.stat.gov.pl](http://www.stat.gov.pl), access: 20.03.2018)

<sup>4</sup>The data was collected using the Z-12 form, which should be filled out by the selected entities of the national economy, in which the number of employed persons exceeds 9 persons and apply only to those employees who worked through the whole

The study used the applicable classification of occupations and specialities, which allowed to distinguish the 8 most important groups of occupations, i.e. the representatives of public authorities, senior officials and managers (this group includes professions, such as management and commercial managers or production and service managers), specialists (this group includes such professions as specialists for economic matters and management, specialists for information and communication technology, etc.), technicians and middle personnel (this group includes professions, such as middle personnel for business and administration matters, middle personnel in the field of law, social affairs, culture and related, or the IT technicians), office workers (this group includes secretaries, office equipment operators, customer service employees, financial and statistical personnel, and material register employees), personal service employees and salespersons, industrial workers and craftsmen (this group also includes electricians and electronic engineers), machine and device operators (including drivers, vehicle operators), employees of simple tasks (this group consists of cleaners, auxiliary workers or other employees employed at simple tasks)<sup>5</sup>. In the ICT sector, employees are employed in the majority of professions distinguished by the legislator (they are only missing the groups of foresters and fishermen and street vendors and employees providing services on the streets), which allows the analysis of the occurrence of the gender pay gap phenomenon in cross-sections, both at positions requiring high qualifications, as well as those where they are not required. The diagrams below illustrate the remuneration developments for specific groups of professions in the ICT industry in Poland in 2010-2016 (real prices from 2010, PLN). For comparison, the minimum and average remunerations in Poland were also presented.

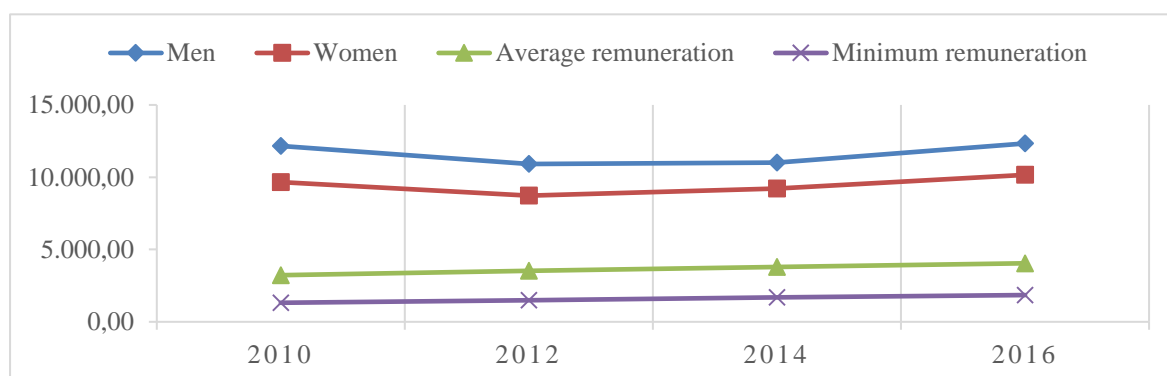

Figure 2: The representatives of public authorities, senior officials and managers, own study based on Official Gazette of the Republic of Poland Monitor Polski 2009, No 48 item 709, Journal of Laws 2011 No 192 item 1141, Journal of Laws 2013 item 1074, Journal of Laws 2015 item 1385, [www.stat.gov.pl](http://www.stat.gov.pl), [www.zus.pl](http://www.zus.pl).

Remuneration in groups of representatives of public authorities, senior officials and managers, specialists and technicians and medium personnel were several higher than the average remuneration in the Polish economy, they also significantly diverged from the minimum wage, which is related to the need to provide employees with specialist knowledge and, as a consequence, above-average remuneration (Widowicz-Giegiel, 2013, p. 538). A similar situation took place in the next group of professions, i.e. specialists, presented in Figure 3.

October. It is worth noting that the presented results do not concern, among others, persons who benefited from maternity and parental leaves during that time and people on sick leave, and that the study did not cover all entities of the national economy and the results were presented in a generalized way, however, allowing the characterization of the level of remuneration in the ICT sector in terms of gender, as well as profession, which makes them valuable in further analysis.

<sup>5</sup> The Classification of professions and specialities applied, was introduced by the Regulation of the Minister of Labour and Social Policy of April 27, 2010 on the classification of professions and specialities for the needs of the labour market and the scope of its application (Journal of Laws no. 82, item 537).

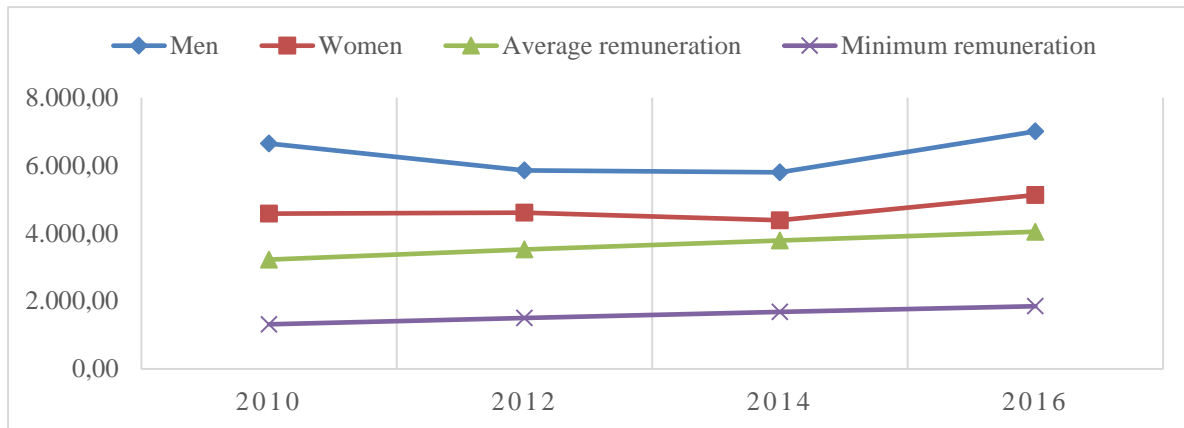

Figure 3: Specialists, own study based on Official Gazette of the Republic of Poland Monitor Polski 2009, No 48 item 709, Journal of Laws 2011 No 192 item 1141, Journal of Laws 2013 item 1074, Journal of Laws 2015 item 1385, [www.stat.gov.pl](http://www.stat.gov.pl), [www.zus.pl](http://www.zus.pl).

Analysing the remuneration of specialists, it can be noticed that the wages of men and women are still higher than the average wage in the country and much higher than the minimum wage. However, the disproportion between wages has increased in favour of men. The salaries of the technicians and middle personnel in the analysed period were lower than the salaries of specialists, but their amount was still higher than the average remuneration and much higher than the minimum wage, which was presented in Figure 4.

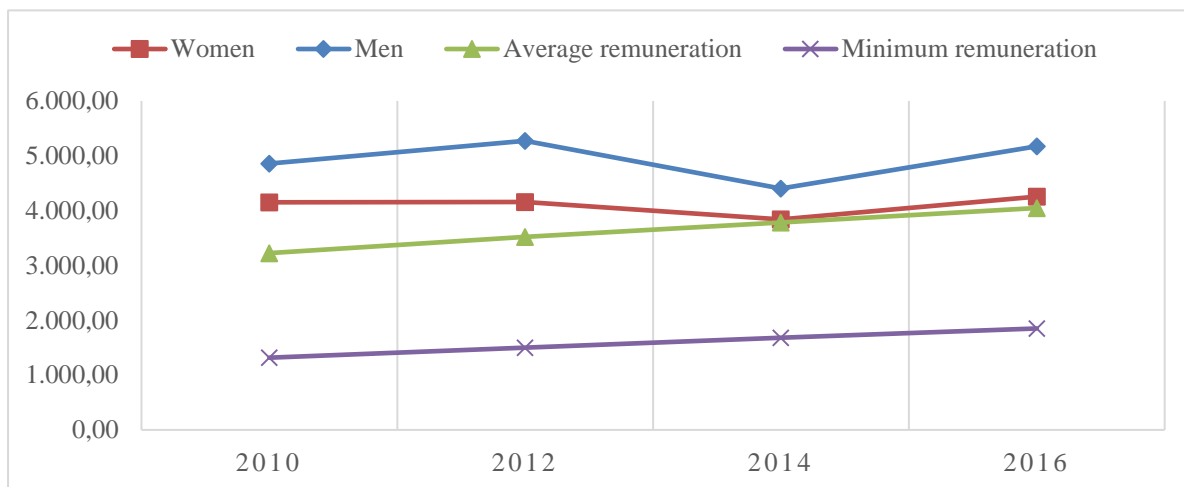

Figure 4: Technicians and middle personnel, own study based on Official Gazette of the Republic of Poland Monitor Polski 2009, No 48 item 709, Journal of Laws 2011 No 192 item 1141, Journal of Laws 2013 item 1074, Journal of Laws 2015 item 1385, [www.stat.gov.pl](http://www.stat.gov.pl), [www.zus.pl](http://www.zus.pl).

Remuneration of the next analysed group, i.e. office workers, was close to the average salary in the analysed years, which was presented in Figure 5.

Figure following on the next page

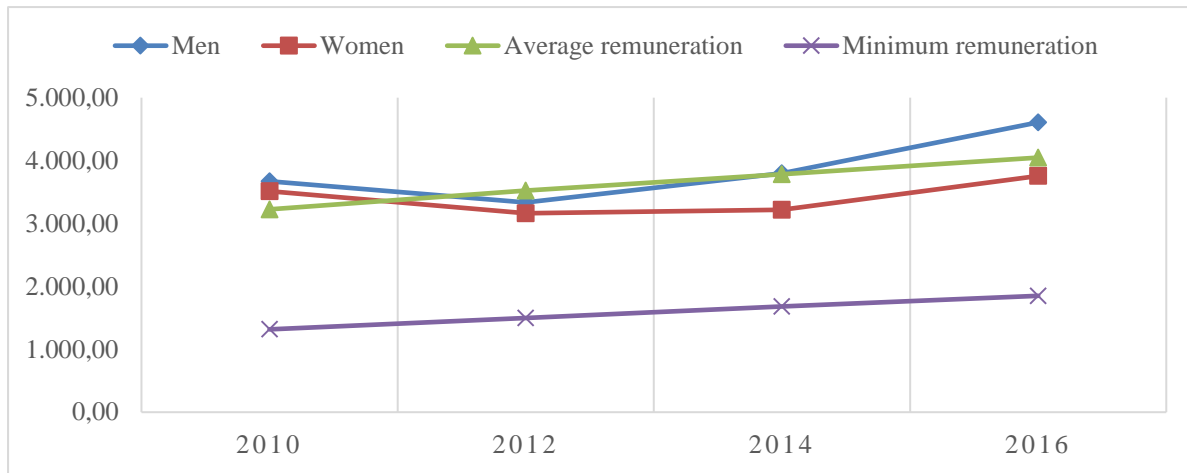

Figure 5: Office workers, own study based on Official Gazette of the Republic of Poland Monitor Polski 2009, No 48 item 709, Journal of Laws 2011 No 192 item 1141, Journal of Laws 2013 item 1074, Journal of Laws 2015 item 1385, [www.stat.gov.pl](http://www.stat.gov.pl), [www.zus.pl](http://www.zus.pl).

The remuneration of this group of employees was more than twice as high as the minimum wage, but it did not differ from the average remuneration in the Polish economy. The amount of this remuneration may be related to lower qualifications requirements. Employees employed in these positions are mostly characterized by lower education than employees employed in specialist positions (Adamczyk, Jarecki, 2008, p. 14). A similar relationship is also visible in the group of service employees and salespersons. Another group of professions, industrial workers and craftsmen, includes employees who are characterized by low qualifications (Węgrzyn, 2015, p.94). The level of remuneration in this group is presented in Figure 6.

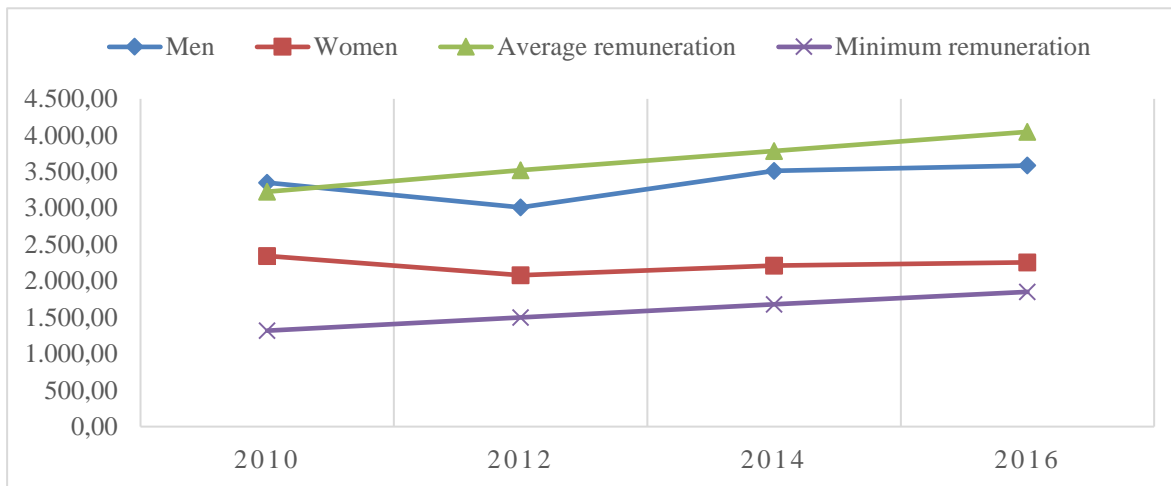

Figure 6: Industrial workers and craftsmen, own study based on Official Gazette of the Republic of Poland Monitor Polski 2009, No 48 item 709, Journal of Laws 2011 No 192 item 1141, Journal of Laws 2013 item 1074, Journal of Laws 2015 item 1385, [www.stat.gov.pl](http://www.stat.gov.pl), [www.zus.pl](http://www.zus.pl).

In this group of professions, men earned on average 50% more than women in the entire analysed period. It is worth noting that in general in this group of occupations (among others due to the nature of the profession), there were far more male employees (cf. Kwiatkowska, 2013, p.188). A similar relationship is also visible in the group of machine and device operators. The average level of remuneration of the last analysed group (employees of simple tasks) was presented in Figure 7.

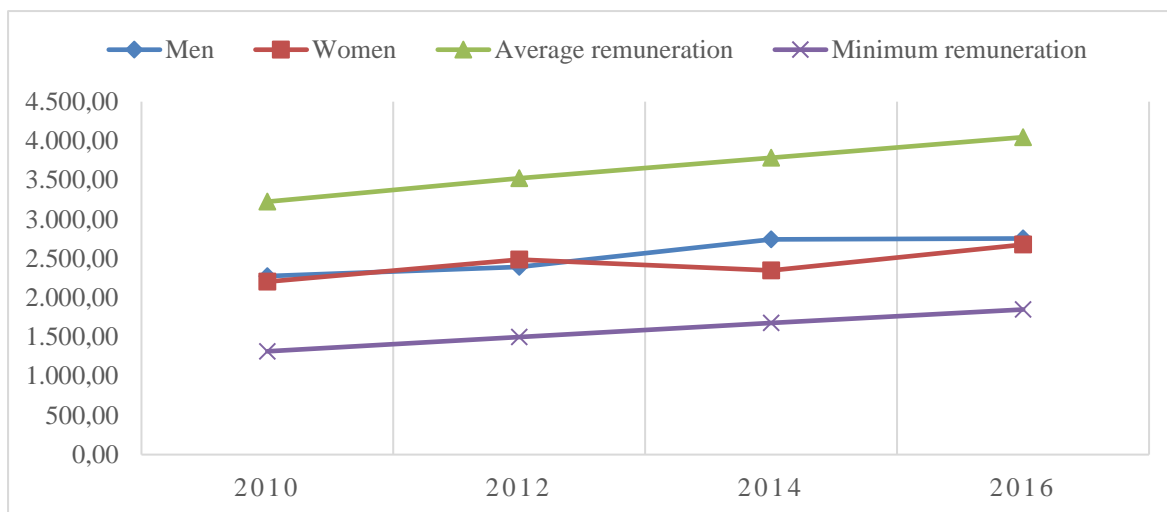

Figure 7: Employees of simple tasks, own study based on Official Gazette of the Republic of Poland Monitor Polski 2009, No 48 item 709, Journal of Laws 2011 No 192 item 1141, Journal of Laws 2013 item 1074, Journal of Laws 2015 item 1385, [www.stat.gov.pl](http://www.stat.gov.pl), [www.zus.pl](http://www.zus.pl).

Employees classified in this group most often have an elementary level of education (Roszkowska, Rogut, 2007, p.71). This group is also characterized by the lowest wages compared to all analysed groups. It is worth noting, however, that despite the lowest level of remuneration, the lowest level of the gender pay gap was recorded in this group. Taking into account all the groups of professions distinguished in the ICT sector, it can be concluded that in the analysed years, men earn more than women and the gender pay gap occurred in each group of occupations (regardless of whether the position required high or low qualifications), which has confirmed the first hypothesis set at the beginning of the study. When analysing the detailed source data, one can observe only a few cases when the women's remuneration in the analysed period is higher than men's (e.g. in 2012 and 2014 women employed in the group of professions medium personnel in the field of law, social affairs, culture and related received approx.. 40% and 8.6% higher remuneration, respectively, than men at the same positions; in 2012, women employed in a group of secretaries, office equipment operators and related earned approx.. 23% more than men at a similar position), but these were individual cases. The biggest pay disparities in favour of men in the analysed period were present in the following groups of professions (in each analysed year, men earned at least 1/5 more than women employed at a similar position: specialists in physical, mathematical and technical sciences; health specialists; specialists in economic affairs and management (group of specialists – diagram 3.); middle health personnel (group of technicians and other middle personnel – diagram 4.); craftsmen and printing workers, workers in food processing, wood processing, textile production and related (group of industrial workers and craftsmen – diagram 6.).

#### 4. ANALYSIS OF RELATIONS BETWEEN THE PERFORMED PROFESSION AND GENDER PAY GAP

When analysing the linear relations between two variables, one can use Pearson's linear correlation coefficient, which is used to identify the strength of one variable's impact on the other (cf. Roszkowska, 2013, pp. 118-119, Dykas, 2013, p. 68). This study attempts to verify whether the position on which a given employee is employed affects the disproportion in remuneration between men and women providing work of the same nature. The correlation coefficient can be written using the following formula (cf. Pearson, 1895, p. 241):

$$r = \frac{n \cdot \sum W_{it} GAP_{it} - \sum W_{it} \cdot \sum GAP_{it}}{\sqrt{[n \cdot \sum W_{it}^2 - (\sum W_{it})^2] [n \cdot \sum GAP_{it}^2 - (\sum GAP_{it})^2]}}$$

where:

n- number of observations,

GAP<sub>it</sub>- inter-gender pay gap in the *i*-th profession in the *t*-year<sup>6</sup>;

W<sub>it</sub>- total remuneration in the *i*-th profession in the *t*-year<sup>7</sup>.

From the estimation of Pearson's correlation coefficient, which amounted to 0.1464 for the examined variables, it can be concluded that on the basis of the analysed data concerning the profession and the difference of remuneration for women and men providing work at a similar position in the ICT industry in 2010-2016, the mutual dependence cannot be identified (the value of Pearson's linear correlation coefficient is very low). This means that the gender pay gap has occurred in the analysed period in every profession in the ICT industry regardless of whether the position required specialized knowledge or qualifications or not. Therefore, on the basis of the presented data, the second hypothesis formed at the beginning of the study cannot be confirmed. Lack of dependence between the profession and the level of the gender pay gap can also be seen in the graphs presenting the level of remuneration in individual occupational groups in the ICT sector in 2010-2016. The lowest level of the gender pay gap in the analysed period occurred in the group of employees of simple tasks (Figure 7.) and the highest in the group of industrial workers and craftsmen (Figure 6.) However, this does not mean that the disproportion in the remuneration of women and men in the ICT industry in Poland in the analysed period can be associated with the phenomenon of discrimination. The presented pay gap may be affected by numerous other factors, both quantitative and qualitative (Śliwicki, 2015, p. 17). However, at this point it is worth noting that the analysis presented in the study, despite its simplified nature, may become a contribution to further research, e.g. by including further variables, such as education at a given position, family status or work seniority.

## 5. CONCLUSION

The role of the information and technology service sector is gradually accentuated not only because of the impact on other sectors of the economy, improvement of the state's competitiveness against the background of the international arena, as well as enhancement of the employees' work efficiency. However, it is worth noting that when assuming the classification of similar qualifications of people performing the same profession, the work performed by men and women at a similar position is not paid equally. The presented analysis confirms the first hypothesis presented in the study that the pay gap in favour of men in the ICT industry in Poland exists and applies to each group of professions, both in terms of positions requiring specialist knowledge (representatives of public authorities, seniors officials and managers, specialists), as well as those that do not require education (employees of simple tasks). The empirical material gathered did not give grounds to confirm the second hypothesis, i.e. that the gender pay gap is greater at positions requiring higher qualifications. The analysis presented that the lowest level of the gender pay gap occurred in the group of employees of simple tasks and the highest in the group of industrial workers and craftsmen. The lack of this relationship was also confirmed by the correlation coefficient result. This means that the negative phenomenon of disproportion between the remuneration of men and women affects

---

<sup>6</sup> The gender pay gap, in accordance with the practice of the Central Statistical Office ([www.stat.gov.pl](http://www.stat.gov.pl)), has been presented as the difference between the remuneration of women and men in relation to the men's salary expressed in percentage.

<sup>7</sup> [www.stat.gov.pl](http://www.stat.gov.pl) (access 20.03.2018)



employees in each group of professions and raises the need for further analysis using additional variables, both qualitative and quantitative in nature.

**ACKNOWLEDGEMENT:** *This work was financed with funds for research or development of works and related tasks for the development of young scientists and participants of doctoral studies.*

#### **LITERATURE:**

1. Adamczyk A., Jarecki W. (2008). Szacowanie wewnętrznej stopy zwrotu inwestycji w wyższe wykształcenie, *Gospodarka Narodowa*, No 11-12/2008, pp. 77-93.
2. Announcement of the Prime Minister of 24 July 2009 on the amount of the minimum remuneration for work in 2010 (Official Gazette of the Republic of Poland Monitor Polski 2009, No 48 item 709).
3. Dykas P. (2013). Zróżnicowanie podstawowych zmiennych makroekonomicznych w województwach. W: Trojak M. *Regionalne zróżnicowanie rozwoju ekonomicznego Polski* (pp. 65-90). Kraków: Wydawnictwo Uniwersytetu Jagiellońskiego.
4. Gomółka, A. (2018). The impact of regional specialization on wages of women and men in ICT sector in Poland in 2012-2016, *Economic and Environmental Studies*, (Vol.18, No 2 (46/2018), pp. 591-609).
5. Kwiatkowska W. (2013). Zatrudnienie według grup zawodów i sektorów ekonomicznych w polskiej gospodarce, *Acta Universitatis Lodzianensis. Folia Oeconomica*, 281/2013, pp. 179-211.
6. Majchrowska A., Mroczek K., Tokarski T. (2013). Zróżnicowanie stóp bezrobocia rejestrowanego w układzie powiatowym w latach 2002-2011, *Gospodarka Narodowa*, (No 9), pp. 70-88.
7. Mincer J. (1958), Investment in Human Capital and Personal Income Distribution, *Journal of Political Economy*, (No 66), pp. 291-302.
8. Mincer J. (1974), *Schooling, Experience and Earnings*, National Bureau of Economic Research, New York.
9. Pearson K. (1895). Notes on regression and inheritance in the case of two parents. *Proceedings of the Royal Society of London*, (58/1895), pp. 240-242.
10. Regulation of the Council of Ministers of 24 December 2007 on the Polish Classification of Activities (PKD) (J.L. 251, item 1885).
11. Regulation of the Council of Ministers of September 13, 2011 regarding the amount of the minimum remuneration for work in 2012 (Journal of Laws 2011 No 192 item 1141).
12. Regulation of the Council of Ministers of September 11, 2013 regarding the minimum remuneration for work in 2014 (Journal of Laws 2013, item 1074).
13. Regulation of the Council of Ministers of September 11, 2015 regarding the minimum remuneration for work in 2016. (Journal of Laws, 2015, item 1385).
14. Regulation of the Minister of Labour and Social Policy of 7 August 2014 on the classification of professions and occupation for the labour market and on its scope (J.L. 2014, item. 1145).
15. Roszkowska S. (2013). *Kapitał ludzki a wzrost gospodarczy w Polsce*. Łódź: Wydawnictwo Uniwersytetu Łódzkiego.
16. Roszkowska S., Rogut A. (2007). Rozkład płac i kapitału ludzkiego w Polsce, *Gospodarka Narodowa*, No 11-12/2007, pp. 55-84.
17. Structure of wages and salaries by occupations in October 2010. (2012). Retrieved 19.02.2018 from <http://stat.gov.pl/>.
18. Structure of wages and salaries by occupations in October 2012. (2014). Retrieved 19.02.2018 from <http://stat.gov.pl/>.

19. Structure of wages and salaries by occupations in October 2014. (2016). Retrieved 19.02.2018 from <http://stat.gov.pl/>.
20. Structure of wages and salaries by occupations in October 2016. (2018). Retrieved 19.02.2018 from <http://stat.gov.pl/>.
21. Szczepaniak D., Tokarski T. (2018). Ekonomiczne determinanty migracji międzywojewódzkich, *Wiadomości Statystyczne*, (2(681)/2018), pp. 44-59.
22. Śliwicki D. (2015). Różnice w wynagrodzeniach mężczyzn i kobiet w województwach, *Wiadomości statystyczne*, (10/2015), pp. 17-28.
23. Węgrzyn G. (2015), Wykształcenie i kwalifikacje pracowników jako determinanta zmian w poziomie innowacyjności gospodarek, *Ekonomia XXI wieku*, No 1(5)/2015, pp. 90-100.
24. Widowicz- Giegiel A. (2013). Rentowność a zdolność konkurencyjna sektora technologii informacyjnych i komunikacyjnych w Polsce, *Zarządzanie i Finanse*, (No 2/2013), pp. 531-542.
25. Witkowska D., Matuszewska-Janica A., Kompa K. (2016). Wybrane aspekty aktywności zawodowej kobiet w sektorach turystycznym oraz ICT w krajach regionu Morza Bałtyckiego, *Kobieta i Biznes*, (No 1-4/2016), pp. 3-13.
26. The Constitution of the Republic of Poland of 2<sup>nd</sup> April, 1997 (Journal of Laws no. 78, item 483 as amended).

# THE SYMBIOTIC RELATIONSHIP BETWEEN STARTUPS AND INCUBATORS

**Joao Sousa**

*FEP, University of Porto, Portugal  
joaopedropina15@gmail.com*

**Raquel Meneses**

*FEP, University of Porto, Portugal  
raquelm@fep.up.pt*

**Humberto Ribeiro**

*GOVCOPP, ESTGA, University of Aveiro, Portugal  
hnr@ua.pt*

**Sandra Raquel Alves**

*CIC.DIGITAL, ESTG, Polytechnic Institute of Leiria, Portugal  
raquel.alves@ipleiria.pt*

## ABSTRACT

*As the number of “garage” startups that became ending very large and influential corporations continues to increase, no one can disregard them anymore. Indeed, startups are increasingly regarded as potential powerful engines of innovation and incredible fast growth, being able to change the way how society and economies operate, as they often coin new visions, coupled with the inception of new technologies. Becoming easily state-of-the-art businesses, the number of startups achieving the unicorn status is not standstill either, adding therefore further interest to this phenomenon. Nevertheless, managing a startup is often harsh, and the great majority fail soon after being founded. It is very hard for entrepreneurs to achieve success, and the star status achieved by a few of them reveals to be a mirage to barely every startup. It is therefore natural to recognise the importance of the incubators for these new, fresh, but fragile forms of businesses. Accordingly, this paper has the purpose to try to understand and evaluate the startups’ expectations and what the incubator truthfully offers for their development, as well as to verify whether such expectations match with the reality offered. Furthermore, it is expected that this paper may have practical and social implications, as it attempts to contribute to the incubators’ strategies and actions, allowing them to analyze externally and internally the needs and motivations of their incubates. Concurrently, this research presents also a valuable contribution for the startups and for the regions where they are headquartered. This work is actually based on the startups perspective, which will contribute to a more efficient and adapted relationship between startups and incubators, since it emphasizes on what they actually expect and perceive from the incubation process.*

**Keywords:** *Startups, Incubators, Management, Customer Satisfaction, Innovation, Performance, Entrepreneurship*

## 1. INTRODUCTION

As the number of “garage” startups that became ending very large and influential corporations continues to increase, no one can disregard them anymore. Indeed, startups are increasingly regarded as potential powerful engines of innovation and incredible fast growth, being able to change the way how society and economies operate, as they often coin new visions, coupled with the inception of new technologies. Becoming easily state-of-the-art businesses, the number of startups achieving the unicorn status is not standstill either, adding therefore further interest

to this phenomenon. Nevertheless, managing a startup is often harsh, and the great majority fail soon after being founded. It is very hard for entrepreneurs to achieve success, and the star status achieved by a few of them reveals to be a mirage to barely every startup. The life cycle of a company is very volatile and the first years are fundamental for the continuity of the business. Initially these types of companies may find it more difficult to approach their target audience for several reasons. Lack of knowledge on the part of the market, adversity to change by the market, size and novelty are some reasons. This need for support from new companies represents a market opportunity. Although incubators are one of the most relevant and dominant approaches to supporting emerging companies, there are other possible options for an early stage business. Thus the choice to integrate an incubation process reflects the startup's expectation of the value that an incubator can add, since this strategic decision will be decided taking into account the expectations that incubate form on the various options. It is therefore natural to recognise the importance of the incubators for these new, fresh, but fragile forms of businesses. Accordingly, this paper has the purpose to try to understand and evaluate the startups' expectations and what the incubator truthfully offers for their development, as well as to verify whether such expectations match with the reality offered. Furthermore, it is expected that this paper may have practical and social implications, as it attempts to contribute to the incubators' strategies and actions, allowing them to analyze externally and internally the needs and motivations of their incubates. Concurrently, this research presents also a valuable contribution for the startups and for the regions where they are headquartered. This work is actually based on the startups perspective, which will contribute to a more efficient and adapted relationship between startups and incubators, since it emphasizes on what they actually expect and perceive from the incubation process.

## **2. THE INTRINSIC FRAGILITY OF STARTUPS AND THE IMPORTANCE OF INCUBATORS**

Besides being considered as a fresh approach to the markets, the startups are also regarded as a tool for job creation and development in the region where they operate, contributing to their growth. For recent years in Portugal, these emerging companies accounted for 6.5% of the business fabric (Magazine, 2016) and 18% of new employment in 2014 (D & B, 2016), yet most of their leaders were undertaking for the first time what underlies the potential lack of knowledge, both at the business model level and at the level of contacts, such as the difficulty in raising financial resources. These difficulties are evidenced by the survival rate of these companies. A third of these companies do not survive the first year of activity and only half of them exceed three years (D & B, 2017c). These values arise due to the inexperience of the entrepreneurs, market dynamics, lack of awareness of the company or even the business idea that, consequently, can make it difficult to obtain financial support and contacts. In resume, it seems very important to reflect on the best technique and method of development of emerging companies since, today, they have a significant weight in our economy. The relationship between incubators and new companies has been analyzed by several authors (Al-Mubarak and Busler, 2010; Dee, Livesey, Gill, and Minshall, 2011; Mas-Verdú, Soriano, and Tierno, Chinsomboon, 2000; Grimaldi and Grandi, 2005; Mian, 1996; Theodorakopoulos, Kakabadse, and McGowan, 2014). Nevertheless, the results differ, mainly due to the different periods of analysis and the different regions, and as published by Forbes in 2014, "it has not yet been proven that a business will be more successful if it is associated with an incubator" (Forbes, 2014). However, according to the literature, incubators provide several benefits that favor the creation, growth and stability of new companies such as cheaper rents, support services, location, among others. Nonetheless, in a number of empirical studies on the relationship between an incubator and an incubator (Al-Mubarak and Busler, 2010; Bollingtoft and Ulhøi, 2005; Tötterman and Sten, 2005), these benefits have been analyzed from an incubator

perspective, not from the new companies. For the acquisition and organization of information, many studies carry out surveys targeting incubators. It is a useful but limited method since it cannot represent the point of view of the incubated ones, hindering a correct evaluation of the perspective of the new companies (Dee et al, 2011). It is important to assess the impact of incubators as their role is transversal, allowing, in principle, to suppress market failures, promote regional development, create jobs, and generate opportunities through the exchange and transfer of technology between clients and incubated enterprises. For the local and national community, incubators can still create self-esteem and an entrepreneurial culture. With regard to research institutions and universities, business incubators can help strengthen interaction and promote the commercialization of research (Al-Mubaraki and Busler, 2010). For startups, there is evidence that companies associated with business incubators present better values in terms of sales growth and employability, survival, formation of commercial and technical beneficial relationships (Scillitoe and Chakrabarti, 2010) and increase the likelihood of success (Al-Mubaraki and Busler, 2010), by modifying or accelerating the economic development process of startups (Dee et al, 2011). Prospects for survival and growth of new businesses may depend on the ability to capture external resources. Thus, one of the tasks of incubators is the transition from a resourceless company to a resource-sustainable enterprise (Zhao and Aram, 1995). Recognizing the relationship between an incubator and the startups, it is important to analyze whether the option to integrate the incubation process is the solution expected by the emerging companies for their development (Dee et al, 2011). For Buys and Mbewana (2007), business incubators help new companies to survive and grow during their initial period, however it is recognized that incubators do not always lead to better incubation results (Dee et al, 2011; Buys and Mbewana, 2007) and, given the credit and large investment given to incubators by government, universities, research institutions, there are even those who question what return the startups get (Bergek and Norrman, 2008). One issue that has arisen is that companies usually have to undergo a careful selection process to be incubated (business plan, financial budget, product rights, etc.) (Schwartz, 2010), in the However, this selection process can only be imposed if the incubators are strong enough to refuse certain applications (Dee et al, 2011), that is, "Harvard students are successful because of what Harvard does for them or because Harvard selects only students who will succeed regardless of what Harvard does for them?" (Bears, 1998, op. cit Hackett and Dilts, 2004, p.65). The selection refers to decisions about which firms to accept and which to reject (Bergek and Norrman, 2008). Selecting firms with high growth potential is an uncertain and imperfect process (Dee et al, 2011), where business incubators point to a specific group of companies (Hackett and Dilts, 2004). It is important to have a good fit between the services that the incubator is able to provide and the needs of the incubated so that the variability, the sorting and the selection of the incubated do not lead to failure (Hackett and Dilts, 2004; Dee et al., 2011). Some progress has been made to understand how incubated companies develop within an incubator (Dee et al, 2011) and an increase in the presentation of empirical evaluations demonstrating the efficiency of the incubator may be observed (Schwartz, 2010). Incubator supporters suggest that the process can protect incubators from Porter's five forces, increasing the likelihood of survival in the short term while; other authors claim that the same process may weaken the company's ability to compete and survive when it is finished and to leave the incubator (Dee et al, 2011). Many of the incubates have negative cash flow during the initial period (Burgel and Murray, 2000) and are faced with a discrepancy between the key resources needed for efficient marketing of their products or services and their resource base (Schwartz, 2010 Burgel and Murray, 2000). New organizations also have to overcome other issues such as market entry, capital increase by skeptical sources and recruitment (Aldrich and Fiol, 1994), greater uncertainty in a competitive environment (Baldwin, Gellatly, and Gaudreault, 2002) and resource constraint by (Yli-Renko, Autio, and Sapienza, 2001). In this context, in the early years after market entry, new firms face some disadvantages because their

customer relationships are not yet formed (Burgel and Murray, 2000). The first effect is dubbed "novelty susceptibility" and describes the high risk of failure because they do not yet have the resources and / or portfolio needed for their survival (Schwartz, 2010). Customer reluctance can affect product performance (Burgel and Murray, 2000). Similar arguments are made by supporters of the hypothesis of the "susceptibility of smallness", where instead of focusing on the age of enterprise; they take into account the impact of organizational size as an alternative explanation for increasing the probability of survival over time (Schwartz, 2010). In addition, new firms need time to gain market legitimacy (Aldrich and Fiol, 1994). Business incubators can be considered theoretically as an instrument of response to these "susceptibilities" (Schwartz, 2010). However, the relationship between incubators and new organizations is not homogeneous (Al-Mubarak and Busler, 2010) and their variations depend on the "resource-based view", since the distribution of resources directs business incubators to different competitive advantage in creating and developing new companies (M'Chirgui, 2012). There are a variety of services and factors provided by the incubators for their incubators from the initial stage of development of the idea to its growth (M'Chirgui, 2012), which can influence the performance and growth of startups (Silva, 2015) and their success (Theodorakopoulos et al, 2014). The key benefits of an incubator vary according to their size (Theodorakopoulos et al, 2014), with external stakeholders including community (both local / national and international), research institutes, government, business (Al-Mubarak and Busler, 2010), with the temporal space (Bergek and Norrman, 2008) and also with the new incubated companies that allow the incubator to transfer, store and channel knowledge to support other incubations in the future (Hackett and Dilts, 2004 ). The services offered by the incubator have two functions: to prevent the failure of the new companies and to ensure the success of the companies (Vanderstraeten and Matthyssens, 2012). The more extensive these factors are represented in the incubator, the greater the likelihood of incubation success (Theodorakopoulos et al, 2014). The incubation program does not provide support only from the enterprise level, such as the provision of a low-cost space, access to physical facilities and facilities, support services (Cornelius and Bhabra-Remedios, 2003), but also from the hard-to-imitate abilities incorporated into the system, helps socially, typically through intra-organizational and extra-organizational connections (Mian 1996, Lane and Lubatkin, 1998). Social capital is one such service (Adlesic and Slavec, 2012). Incubator facilities and resources minimize a number of associated challenges and facilitate networking (McAdam and McAdam, 2008). Studies suggest that business incubators can actively facilitate and support "networking" among incubator entrepreneurs as well as between these and other external stakeholders, by whom business opportunities are identified and exploited (Theodorakopoulos et al, 2014; Scillitoe and Chakrabarti, 2010). In addition to social capital, Mian (1996) points to government support and low rental costs, as other factors will have an impact on incubator development. Business incubators are linked to a number of other factors that play a role in incubator development, such as trust (Tötterman and Sten, 2005), resource sharing, laboratories, equipment (Chan and Lau, 2005), space rental (Lose, Tengeh, Maziriri and Madinga, 2016), capital funds, state concessions, incentives, low interest rates, private partnerships (Al-Mubarak and Busler, 2010), coaching, training (Bergek and Norrman, 2008), business support (Cornelius and Bhabra-Remedios, 2003), resource sharing (InfoDev and WorldBank, 2009).

### **3. THE INCUBATOR'S CONTRIBUTION FOR THRIVING STARTUPS**

Although not necessarily ensuring the success of the startups, an incubator may provide several relevant services easing their implementation process and providing some help for future growth. Some of such dimensions are now examined.

### **3.1. Space rental**

The rental of space consists of renting a physical space with favorable conditions for the incubated ones (Bergek and Norrman, 2008). Incubated companies have several benefits from economies of scale when they lease facilities together and share the resources of the incubator (Bruneel et al, 2012), since rents are one of the largest expenditures of inexperienced companies (Abduh et al, 2007). The rental of a subsidiary space in addition to giving access to infrastructure at a reduced cost (Cornelius and Bhabra-Remedios, 2003) and in flexible terms (leased space can be changed and / or terms of payment negotiated) (Abduh et al. , 2007), also translates into the reduction of general costs such as energy, water and telecommunications (Bruneel et al, 2012). In addition, the incubated do not have to spend time or resources managing complementary services, allowing the total concentration in their activities. Finally, this factor allows incubators to obtain and subsequently share with their incubators certain government benefits (Bruneel et al, 2012).

### **3.2. Financing**

The lack of financial capital impairs the development of firms and, consequently, their growth (Baldwin et al., 2002; Zhao and Aram, 1995). Access to finance is a critical point for the development and growth of startups (Silva, 2015), but their access remains one of the great challenges for small companies and many studies suggest that new companies rely on too much source to obtain financial resources to overcome the initial difficulties (Baldwin et al., 2002). Incubators must be able to raise capital and provide risk management and tax management services to these new companies (Buys and Mbewana, 2007). As capital is needed at various stages of the business development process, the incubator must act as an intermediary in order to facilitate interaction between clients and potential investors (Abduh et al, 2007). Incubators help start-ups by providing access to financial support that can be obtained from various sources, including government support, commercial banks and investment firms (Buys and Mbewana, 2007).

### **3.3. Sharing services and resources**

The supply of space is fundamental for business incubators and has been identified by the incubators as the factor that most benefits them (Bruneel et al, 2012). The "abundance" of incubator space allows startups to share the facilities and equipment they need but typically cannot afford, neglect, or ignore (Abduh et al., 2007). The sharing of facilities not only goes through the office space, but also through conference rooms, meeting rooms or even more specialized resources such as laboratories or research equipment (OECD, 1997; Grimaldi and Grandi, 2005). All this variety of facilities available for sharing offers distinct advantages, particularly when interacting with the customer (McAdam and McAdam, 2008), but also reduces costs and saves time (Abduh et al, 2007). Another advantage obtained by using the facilities is their environment. Incubators are located where access to science and technology are readily available (Buys and Mbewana, 2007).

### **3.4. Business assistance services**

The lack of teams and management capabilities can have a negative influence on the development of startups (Zhao and Aram, 1995) and these generally do not have the necessary management capacity and experience to address and respond to market changes. At the same time they do not have enough knowledge to identify and hire relevant specialties (Bruneel et al, 2012). With this, the success of an incubation may depend on the quality of the management teams operating in the incubator (Buys and Mbewana, 2007). Incubator support covers a wide range of business expansion services, including support in developing the business plan, strategic plan, product development, sales and marketing advice, government regulation

education (Abduh et al, 2007 ), human resources and accounting, financial, management and legal support (Scillitoe and Chakrabarti, 2010). In addition, incubators benefit from learning elements with active coaching and training (Bruneel et al, 2012; Mian, 1996). Coaching consists of individual support initiatives determined to accelerate the learning and skills of development processes, usually from a mentor's assignment, for a certain fee or free of charge (Scillitoe and Chakrabarti, 2010) and enables entrepreneurs to maintain the latest advances and developments (McAdam and McAdam, 2008). Training is also often available in business incubators, playing a positive role in the development of their clients (Aerts et al, 2007). In short, the assistance services try to increase managerial capacities, fill the scarcity of technical knowledge and lack of access to technical assistance (Abduh et al, 2007).

### **3.5. Notoriety and credibility**

One of the great benefits of positioning in an incubator is the credibility of the address (McAdam and McAdam, 2008). The lack of a business address at an early stage of business can be a tricky problem if we relate the credibility, professionalism and durability of a company (McAdam and McAdam, 2008). The credibility and visibility of the incubator for the clients can also be transferred from the word-of-mouth communication between individuals that belong to the contacts and networks of the incubators (Abduh et al, 2007). However, for McAdam and McAdam (2008), as the company grows and "grows older" the concept of incubation may negatively affect the company's credibility as these will be continuously associated with immaturity.

### **3.6. Share capital**

"It is difficult to work alone. It is necessary to be in an environment with different people. You have to be able to join a network, so at least you know what is happening "(McAdam and McAdam 2008: 284). The social context presents entrepreneurs with several constraints, however, it also offers a set of favorable conditions (Aldrich and Fiol, 1994). Social capital is considered an important factor for innovation, organizational advantage and value creation (Adlesic and Slavec, 2012). Tötterman and Sten (2005) even suggest that the development of the social capital of an incubator is a crucial element to incubators. The concept of social capital has a long history (Adlesic and Slavec, 2012) and was originally used to describe the relational resources obtained from personal connections of a community, but is currently also applied in studies on intra- and inter-organizational relationships (Yli-Renko et al, 2001). In an incubator, social capital is extremely relevant and can be exploited from trust (Tötterman and Sten, 2005), networking opportunities, contacts, counselling and support by other incubators (Adlesic and Slavec, 2012). The networking factor consists of a set of individual links that together form the structure of a network (Witt, 2004) and offers a variety of advantages to new companies (Larson, 1992). Partnering with other organizations also offers the opportunity to acquire new knowledge, develop new skills (Yli-Renko et al, 2001) and maximize adaptability to the environment (Larson, 1992). Increasing knowledge and skills from inter-organizational relationships is faster than developing knowledge and skills in the company itself (Bruneel, Yli-Renko and Clarysse, 2010). These relationships include customers, suppliers, investors, governments and research institutions (Larson, 1992) and provide the company with greater market legitimacy (Aldrich and Fiol, 1994). The incubator, in addition to external relations, also creates an environment that enables incubators to obtain synergies among themselves, share experience and learn from each other (Abduh et al, 2007). This diversity of internal sources accentuates the acquisition of knowledge (Yli-Renko et al, 2001). It is also useful for building relationships that can be developed in formal or informal partnerships, joint ventures, buyer / seller, service exchanges or products or even simple information (Tötterman and Sten, 2005).



These links bring other benefits such as discussion and problem solving among incubators (McAdam and McAdam, 2008), access to critical functions that are beyond financial capacity (Larson, 1992) and overcoming resource constraints (Zhao and Aram, 1995; Tötterman and Sten, 2005).

#### **4. CUSTOMER SATISFACTION WITH THE INCUBATING SERVICE**

Although business incubators are a strategically important program for the growth and development of new businesses in the economy, the topic related to customer satisfaction in relation to incubator support has been very limited (Abduh et al, 2007). The startups can be seen as clients of the incubators (Adlesic and Slavec, 2012) one can use research related to customer satisfaction to evaluate them. Customer satisfaction is defined as the client's overall assessment of product and / or service performance over the relationship, whether cumulative or transaction-specific (Gustaffsson, Johnson, and Roos, 2006, Anderson, Fornell, and Lehmann, 1994) and is affected by perceived quality, price and expectations (Anderson et al, 1994). Abdicating price value, it can be considered as the discrepancy between the previous expectations and perceived quality after consumption (Chen and Chen, 2010). Satisfaction to be measured needs a current experience of the product or service, but is also based on previous experiences (Anderson et al, 1994). This satisfaction is determined by the function between the expectations obtained from the beliefs attributed to the service and the perceived quality (confirmation or "disconfirmation" of the expectations) (Bearden and Teel, 1983). According to Abduh et al. (2007), the level of satisfaction depends on the importance and efficiency of the service, and the importance corresponds to the expectations of the customers about the service and the efficiency is the perceived quality and service performance.

##### **4.1. Theory of cognitive dissonance**

The theory of cognitive dissonance was developed by Festinger in 1957 (Cooper and Fazio, 1984) and occurs when two cognitions of an individual are inconsistent with each other, that is, when their actions do not coincide with their beliefs, opinions or attitudes (Bem, 1967). Dissonance is described as a psychological state of discomfort (Cooper and Fazio, 1984), once the individual experiences the pressure of a motivational state, pressure that he will seek to remove by altering one of the dissonances (Bem, 1967). Consumer confusion has become even more of an issue as consumers obtain large amounts of information relevant to decision making (Mitchell and Papavassiliou, 1999). This confusion can result in misuse of the product / service that can lead to customer dissatisfaction, loss of loyalty and a break in brand image, and therefore it is vital for companies to have a clear idea not only to not cause confusion but also to help clients to clarify decision options (Mitchell and Papavassiliou, 1999). "Disconfirmation" is defined as the client's subjective judgments that result from the comparison between expectations and perceptions of perceived performance (Szymanski and Henard, 2001). More specifically, once clients shape their expectations, they eventually compare perceptions of performance with the pre-established level of expectation, with "disconfirmation" occurring when the rating is different from the predetermined expectations (McKinney, Yoon, and Zahedi, 2002).

##### **4.2. Paradigm of the "disconfirmation" of expectations**

A more formal specification of the importance-performance analysis is the "disconfirmation" paradigm (Ennew et al, 1993). The paradigm of "disconfirmation" of expectations has become an important framework for the analysis of customer satisfaction (Yüksel and Yüksel, 2001). This theory indicates that customer satisfaction has three antecedents, expectations, "disconfirmation" and perceived quality (McKinney et al, 2002) and assumes that customer satisfaction arises from an evaluation process in which expectations created from experiences

or previous information and compared with perceptions of service performance (Thompson and Yarnold, 1995; Westbrook and Reilly, 1983). This paradigm implies that customers have a certain expectation with regard to a particular service before its use. After their use the results are compared with the expectations and the "disconfirmation" occurs if there is a difference between the expectations and the perceptions (Yüksel and Yüksel, 2001; McKinney et al., 2002). A client will be satisfied or dissatisfied if the divergence is positive or negative between the expected and the obtained (Wirtza and Bateson, 1999). Thus, when the performance of a service is higher than initially expected there is a positive "disconfirmation" that results in satisfaction (Thompson and Yarnold, 1995). On the other hand, when the service is below expectations, there is a negative "disconfirmation" that causes dissatisfaction (Yüksel and Yüksel, 2001). In the case of incubators, or in a generally long-term context, satisfaction is measured by a cumulative relationship and this will be the evaluation that will most influence the behavior of the companies since it will have an impact in terms of notoriety and recommendation (Gustafsson et al., 2006). One of the purposes of the incubators is to promote the satisfaction of the incubated ones from their services (Adlesic and Slavec, 2012). Incubations are generally dissatisfied with incubator support when the incubation process is predetermined, rather than being re-evaluated as there is a change in business needs (Dee et al., 2011). Satisfaction is important for the incubated because it reflects a positive result from the expenditure of scarce resources and / or satisfaction of unknown needs (Bearden and Teel, 1983). It is also important for incubators since it will make their clients work better and share positive word of mouth communication (Adlesic and Slavec, 2012). As the level of satisfaction acquired by incubator services from the perspective of the clients is fundamental to determining the effectiveness and efficiency of the programs, it is vital to reveal the difference between the expectations of the clients and the performance of the services of the incubators (Abduh et al., 2007). As mentioned above, customer satisfaction and service quality have quality perceived as one of their antecedents (Fornell, Johnson, Anderson, Cha, and Bryant, 1996), and providing a positive perception is essential for the success and survival of a firm in the current competitive environment (Zeithaml, Berry and Parasuraman, 1996), which has been identified as a key factor in gaining competitive advantage (Ennew et al., 1993). Perceived quality corresponds to a customer's appreciation of overall service performance (Tsiotsou, 2005), ie the perceived performance of the incubation program service (Abduh et al., 2007; Fornell et al., 1996). The perceived quality of the SERVQUAL survey is the difference between the expected service and is reflected in five dimensions: ability to fulfill the promise; responsibility of the service; inspire confidence; empathy and tangibility (Donthu and Yoo, 1998). Perceived quality is determinant for customer satisfaction and quality of service in general (Cronin, Brady and Hult, 2000). Perceived quality is different from customer satisfaction for a variety of reasons, based on the characteristics of the products or service, controlled to a certain degree and can be perceived without current consumption / use experience with the possibility of being formed or before or after use (Anderson et al., 1994; Tsiotsou, 2005). The process of quality perception is complicated. It is not only the dimensions of quality that determine whether the quality of service is good or bad (Gronroos, 1988). The impact of perceived quality will always outweigh the impact of expectations, because current experiences tend to be more salient, have more precedents than past experiences, and prevail over any other information (Anderson et al., 1994).

## 5. CONCLUSION

An in depth research was done on the existing literature, regarding initially the startups, the incubators and, later, the relation between them. Due to the relevance of the relationship between these two types of organization, we analyzed the main factors that motivate the startups to be part of the incubation process, such as rental costs, service sharing, negotiation assistance, financing support, social capital and notoriety.

Since the purpose of this paper was the study of the expectations and customer service regarding the perceptions of the startups, covering its surroundings as well. In the follow-up, we recognized the main factors that, from the point of view of existing literature, were considered fundamental for the incubation process and its desired success while effectively supporting the startups in their hard quest to thrive and conquer a place on the market. Albeit not necessarily ensuring the success of the startups, it can be concluded that an incubator may provide several relevant services easing their implementation process and providing some help for future growth of businesses. Regarding customer satisfaction with the incubating service, despite business incubators are a strategically important partner for the growth and development of new businesses in the economy, the examination of the customer satisfaction in relation to incubator support topic related to has been very limited researched (Abduh et al, 2007). Nevertheless, the startups can be regarded as clients of the incubators (Adlesic and Slavec, 2012) and therefore one can use research related to customer satisfaction to evaluate them. As recommendation of future investigations one could suggest to obtain information from both startups' and incubators' perspectives, since it is relevant to compare and analyze them both together in order to obtain an even more in depth view of the relationship between them. Finally, the production of practical guide for the incubators could be highly beneficial. That could include an orientation on how incubators could effectively support the startups, from the selection process to the validation of the incubations, mentioning the main needs and motivations of the incubated ones. Such guide would allow a greater adjustment of incubator support, leading to greater efficiency, increased quality and overall satisfaction.

#### LITERATURE:

1. Abduh, M., D'Souza, C., Quazi, A. and Burley, H. T. (2007), "Investigating and classifying clients' satisfaction with business incubator services", *Managing Service Quality: An International Journal*, Vol. 17, N°1, pp. 74-91.
2. Adlesic, R. V. and Slavec, A. (2012), "Social Capital and business incubators performance: testing the structural model", *Economic and business review*, Vol. 14, N°3, pp. 201-222.
3. Aerts, K., Matthyssens, P. and Vandenbempt, K. (2007), "Critical role and screening practices of European business incubators", *Technovation*, Vol. 27, N°5, pp. 254-267.
4. Aldrich, H. E. and Fiol, C. M. (1994), "Fools Rush in? The Institutional Context of Industry Creation", *The Academy of Management Review*, Vol. 19, N°4, pp. 645-670.
5. Al-Mubarak, H. M. and Busler, M. (2010), "Business incubators models of USA and UK: A swot analysis", *World Journal of Enterprenuership*, Vol. 6, N°4, pp. 335-354.
6. Anderson E. W., Fornell, C. and Lehmann, D. R. (1994), "Customer satisfaction, market share, and profitability: Findings from Sweden", *Journal of Marketing*, Vol. 58, N°3, pp. 53-66.
7. Baldwin, J. R., Gellatly, G. and Gaudreault, V. (2002), *Financing innovation in new small firms: New evidence from Canada*. Ottawa. Statistics Canada, Micro-Economic Analysis Division.
8. Bearden, W. O. and Teel, J. E. (1983), "Selected determinants of consumer satisfaction and complaint reports", *Journal of Marketing Research*, Vol. 20, N°1, pp. 21-28.
9. Bem, D. J. (1967), "Self-perception: An alternative interpretation of cognitive dissonance phenomena", *Psychological Review*, Vol. 74, N°3, pp. 183-200.
10. Bergek, A. and Norrman, C. (2008), "Incubator best practice: A framework. *Technovation*", Vol. 28, N°1, pp. 20-28.
11. Bollingtoft, A. and Ulhoi, J. P. (2005), "The networked business incubator - leveraging entrepreneurial agency?", *Journal of Business Venturing*, Vol. 20, N°2, pp. 265-290.

12. Bruneel, J., Ratinho, T., Clarysse, B. and Groen, A. (2012), "The Evolution of Business Incubators: Comparing demand and supply of business incubation services across different incubator generations", *Technovation*, Vol. 32, N°2, pp. 110-121.
13. Bruneel, J., Yli-Renko, H. and Clarysse, B. (2010), "Learning from experience and learning from others: How congenital and interorganizational learning substitute for experiential learning in young firm internationalization", *Strategic Entrepreneurship Journal*, Vol. 4, N°2, pp. 164-182.
14. Burgel, O. and Murray, G. C. (2000), "The International Market Entry Choices of Start-Up Companies in High-Technology Industries", *Journal of International Marketing*, Vol. 8, N°2, pp. 33-62.
15. Buys, A. J. and Mbewana, P. N. (2007), "Key success factors for business incubation in South Africa: the Godisa case study", *South African Journal of Science*, Vol. 103, N°9, pp. 356-358.
16. Chan, K. F. and Lau, T. (2005), "Assessing technology incubator programs in the science park: the good, the bad and the ugly", *Technovation*, Vol. 25, N°10, pp. 1215–1228.
17. Chen, Ching-Fu, and Chen, Fu-Shian. (2010), "Experience quality, perceived value, satisfaction and behavioral intentions for heritage tourists", *Tourism Management*, Vol. 31, N°1, pp. 29-35.
18. Cooper, J. and Fazio, R. H. (1984), "A new look at dissonance theory", *Advances in experimental social psychology*, Vol. 17, pp. 229-266.
19. Cornelius, B. and Bhabra-Remedios, R. (2003), Cracks in the egg: improving performance measures in business incubator research, *16th Annual Conference of Small Enterprise Association of Australia and New Zealand* (pp. 1-19), Ballarat, 28 September-1 October.
20. Cronin, J. J., Brady, M. K. and Hult, G. T. (2000), "Assessing the effects of quality, value, and customer satisfaction on consumer behavioral intentions in service environments", *Journal of Retailing*, Vol. 76, N°2, pp. 193-218.
21. D&B, I. (2016), *Onde nasce o novo emprego? Criação de emprego em Portugal 2007-2014*. Lisboa: Informa.
22. Dee, J. N., Livesey, F., Gill, D. and Minshall, T. (2011), *Incubation for Growth. A review of the impact of business incubation on new ventures with high growth potencial*, Londres: NESTA.
23. Donthu, N. and Yoo, B. (1998), "Cultural influences on service quality", *Journal of Service Research*, Vol. 1, N°2, pp. 178-186.
24. Ennew, C. T., Reed, G. V. and Binks, M. R. (1993), Importance - Performance Analysis and the Measurement of Service Quality, *European Journal of Marketing*, Vol. 27, N°2, pp. 59-70.
25. Forbes. (2014), *Is a Startup or Accelerator right for you*. Forbes:  
<http://www.forbes.com/sites/georgedeeb/2014/08/28/is-a-startup-incubator-or-accelerator-right-for-you/#225a74b03386> Acedido a 12 de Agosto de 2016.
26. Fornell, C., Johnson, M. D., Anderson AND. W., Cha, J. and Bryant, B. E. (1996), "The American Customer Satisfaction Index: Nature, purpose, and findings", *Journal of Marketing*, Vol. 60, N°4, pp. 7-18.
27. Grimaldi, R. and Grandi, A. (2005), Business incubators and new venture creation: an assessment of incubating models. *Technovation*, Vol. 25, N°2, pp. 111-121.
28. Gronroos, C. (1988), "Service quality: The six criteria of good perceived service", *Review of Business*, Vol. 9, N°3, pp. 10-13.
29. Gustafsson, A., Johnson, M. D. and Roos, I. (2006), The effects of customer satisfaction, relationship commitment dimensions, and triggers on customer retention. *Journal of Marketing*, Vol. 69, N°4, pp. 210-218.

30. Hackett, S. M. and Dilts, D. M. (2004), "A systematic review of business incubation research". *Journal of Technology Transfer*, Vol. 29, N°1, pp. 55-82.
31. InfoDev and WorldBank. (2009), *Mixed-use incubator handbook: A Start-up guide for incubator developers*. Accra, BusyInternet.
32. Lane, P. J. and Lubatkin, M. (1998), "Relative absorptive capacity and interorganizational learning", *Strategic Management Journal*, Vol. 19, N°5, pp. 461-477.
33. Larson, A. (1992), "Network Dyads in Entrepreneurial Settings: A Study of the Governance of Exchange Relationships", *Administrative Science Quarterly*, Vol. 37, N°1, pp. 76-104.
34. Lose, T., Tengeh, R. K., Maziriri and. T. and Madinga, N. W. (2016), "Exploring the critical factors that hinder the growth of incubatees in South Africa", *Problems and Perspectives in Management*, Vol. 14, N°3, pp. 698-714.
35. Magazine, i. (2016), *Proteger e Rentabilizar a Inovação*, de i9 Magazine.  
<http://portal.i9magazine.pt/proteger-rentabilizar-inovacao/>. Acedido a 12 de Janeiro de 2017
36. Mas-Verdú, F., Soriano, D. R. and Tierno, N. R. (2015), "Firm survival: The role of incubators and business characteristics" *Journal of Business Research*, Vol. 68, N°4, pp. 793-796.
37. McAdam, M. and McAdam, R. (2008), "High tech start-ups in University Science Park incubators: The relationship between the start-up's lifecycle progression and use of the incubator's resources" *Technovation*, Vol. 28, N°5, pp. 277-290.
38. M'Chirgui, Z. (2012), "Assessing the performance of business incubators: recent France evidence", *Business and Management Research*, Vol. 1, N°1, pp., 62-76.
39. McKinney, V., Yoon, K. and Zahedi, F. M. (2002), "The Measurement of Web-Customer Satisfaction: An Expectation and Disconfirmation Approach", *Information Systems Research*, Vol. 13, N°3, pp. 296-315.
40. Mian, S. A. (1996), "Assessing value-added contributions of university technology business incubators to tenant firms", *Research Policy*, Vol. 25, N°3, pp. 325-335.
41. Mitchell, VW. and Papavassiliou, V. (1999), "Marketing causes and implications of consumer confusion. *Journal of Product and Brand Management*", Vol. 8, N°4, pp. 319-342.
42. OCDE. (1997), *Technology incubators: Nurturing small firms*. Organisation for economic Co-operation and Development. Paris. Committee for Scientific and Technological Policy
43. Schwartz, M. (2010). A control group study of incubators impact to promote firm survival. *The Journal of Technology Transfer*, Vol. 38, N°3, pp. 302–331.
44. Scillitoe, J. L. and Chakrabarti, A. K. (2010), The role of incubator interactions in assisting ew ventures. *Technovation*, Vol. 30, N°3, pp. 155-167.
45. Silva, F. M. (2015), *The impact of capital structure on startup's growth*. Porto. Universidade do Porto. Master dissertation in Finance.
46. Szymanski, D. M. and Henard, D. H. (2001), "Customer Satisfaction: A Meta-Analysis of the Empirical Evidence", *Journal of the Academy of Marketing Science*, Vol. 29, N°1, pp. 16-35.
47. Theodorakopoulos, N., Kakabadse, N. K. and McGowan, C. (2014), "What matters in business incubation? A literature review and a suggestion for situated theorising", *Journal of Small Business and Enterprise Development*, Vol. 21, N°4, pp. 602-622.
48. Thompson, D. A. and Yarnold, P. R. (1995), "Relating Patient Satisfaction to Waiting Time Perceptions and Expectations: The Disconfirmation Paradigm", *Academic emergency medicine*, Vol. 12, N°2, pp. 1057-1062.
49. Tötterman, H. and Sten, J. (2005), "Start-ups. Business incubation and social capital", *International Small Business Journal*, Vol. 23, N°5, pp. 487-511.

50. Tsiotsou, R. (2005), "Perceived Quality Levels and their Relation to Involvement, Satisfaction, and Purchase Intentions", *Marketing Bulletin*, Vol. 16, N°4, pp., 1-10.
51. Vanderstraeten, J. and Matthyssens, P. (2012), "Service-based differentiation strategies for business incubators: Exploring external and internal alignment", *Technovation*, Vol. 32, N°12, pp. 656-670.
52. Wirtza, J. and Bateson, J. E. (1999), "Consumer Satisfaction with Services: Integrating the Environment Perspective in Services Marketing into the Traditional Disconfirmation Paradigm", *Journal of Business Research*, Vol. 44, N°1, pp. 55-66.
53. Yli-Renko, H., Autio E. and Sapienza, H. J. (2001), "Social Capital, Knowledge Acquisition, and Knowledge Exploitation in Young technology-based firms", *Strategic Management Journal*, Vol. 22, N°6, pp. 587-613.
54. Yüksel, A. and Yüksel, F. (2001), "The expectancy-disconfirmation paradigm: a critique", *Journal of Hospitality e Tourism Research*, Vol. 25, N°2, pp. 17-131.
55. Zeithaml, V. A., Berry, L. L. and Parasuraman, A. (1996), "The Behavioral Consequences of Service Quality", *Journal of Marketing*, Vol. 60, N°2, pp. 31-46.
56. Zhao, L. and Aram, J. D. (1995), Networking and growth of young technology-intensive ventures in China. *Journal of Business Venturing*, Vol. 10, N°5, pp. 349-370.

# MAINTAINING UNION REGULATIONS IN THE FORM OF SECTOR EXCLUSIONS WITH THE DETERMINANT OF THE DEVELOPMENT OF COMPETITIVENESS OF THE EUROPEAN AND EUROPE AUTOMOTIVE MARKET

**Wojciech Lewicki**

*West Pomeranian University of Technology Szczecin,  
Faculty of Economics  
Wojciech.Lewicki@zut.edu.pl*

## **ABSTRACT**

*Body The aim of the article is to draw attention to the essence of research issues regarding the need to maintain legal regulations in the form of sectoral exemptions as determinants of competitiveness development on the European and Polish market of automotive services and products. The verification of the following research hypothesis was used to achieve this goal. Sectoral exclusions are a basic tool that protects this market from the influence of producers of given vehicle brands on the structure of production and sales of cars and spare parts in the European Union and there is a need to extend the regulation after 2023. Achieving this task required the use of appropriate research methods and techniques, such as: analysis of available literature sources, methods of induction and deduction, and observation in order to assess the benefits of this regulation for both the demand and supply side. On the other hand, direct recipients of the presented research results may be both legislative and executive bodies in Poland and the European Union, which in the near future are considering changes in legal regulations in relation to the automotive products and services market.*

**Keywords:** *competitiveness, European Union regulations, sectoral exclusions, services and products, consumer, automotive market*

## **1. INTRODUCTION**

The available literature indicates that the automotive sector is one of the major and larger industries in the European Union (Automotive 2017 pp.4). Strong competition on the automotive market, prompts car concerns to look for the most effective forms of car sales, spare parts and the provision of maintenance services (Lademann 2001 pp. 45). Many years of practice, market knowledge and specific properties of these products (technical complexity, relatively high purchase price) indicate that one of the most effective ways of reaching the consumer is the distribution of these goods and servicing vehicles by distributors (dealers) as part of independent, authorized networks by manufacturers of various car brands or domestic importers. Distribution networks in the automotive sector in the European Union are usually created through a series of distribution agreements (contracts), in particular, contracts on selective or exclusive distribution, belonging to the so-called categories of vertical agreements that constitute an institutionalized form of a qualified network distribution system (Creutzig 2003 p.22). Introduced Regulation no. 1400/2002 in 2002 (Commission 1400/2002), led to significant modifications both in terms of the distribution of passenger cars themselves, maintenance services, but also primarily in the distribution of spare parts. The main purpose of these changes was:

- to support market in the prices of products and services between the Member States of the European Union,
- strengthening the independence of dealers, promoting multi-brand distribution, prohibiting the use of so-called location clauses,

- increasing the level of intra-brand competition in the automotive sector, in particular to overcome significant differences and introducing greater flexibility in servicing vehicles, i.e. repair and sale of spare parts.

Therefore, this Regulation was a good example of interaction between objectives with a view to strengthening competition, on the one hand, and assumptions focusing on supporting market integration on the other hand, taking into account the significant benefits for consumers. Undoubtedly, all these activities had a significant impact not only on the mechanisms of the automotive market, but also related markets (Andersen 2001 pp.23). For example, the motor insurance market and the liquidation of such damages, the market repairs, suppliers or spare parts. On this basis, in 2010, under the pressure of consumers, the European Commission decided to extend the regulation until 1 June 2013, after which it would take another decision to extend the regulation until May 2023 (Commission 2010). In reference to the above presented considerations in recent years in Poland, a public discussion began among both practitioners as well as representatives of the scientific community regarding the answer to the question is there a need to extend the regulation for subsequent years and what effect does these regulations have on the automotive market and related markets? Therefore, undertaking academic considerations in this matter may be crucial, in order to understand the processes affecting the shaping of these mechanisms, both for the automotive sector and related sectors. On the basis of the above presented considerations, the author puts forward a thesis that sectoral exclusions are a basic tool that protects this market from the influence of producers of given vehicle brands on the production structure and sales of cars and spare parts in the European Union and there is a need to extend the duration of this regulation after 2023.

## **2. RESULTS AND DISCUSSION**

Competitiveness policy is one of the main and the earliest agreed community policies. The legitimacy and necessity of conducting it is directly linked to one of the main objectives of the European Communities, which was to create a common market of the Member States. Competitiveness policy is intended to ensure that barriers abolished in internal trade, within the single market, will not be replaced by other actions by enterprises or governments leading to distortion of competition (Porter 1990 pp.56). Competition policy primarily focuses on the interest of consumers and strives to provide them with easy access to goods and services offered on the single market while achieving clear economic benefits. At the same time, by creating conditions for the effective functioning of free competition, it has a positive impact on the competitiveness of EU enterprises on the global market (Porter 1991. Pp95-117). The analysis of legal acts indicates that the competition law of the European Communities takes precedence over national law, but in practice the community system and national solutions operate side by side. Community rules are designed to ensure free competitiveness in the internal market, in trade between Member States; they do not concern individual national markets ( Explanatory Brochure 2002). In the Member States of the European Union, manufacturers of motor vehicles and spare parts distribute their products through distributors' networks. For motor vehicles, these distributors are commonly referred to as dealers (Stanford 2010 p.45). Motor vehicle manufacturers and other companies also run networks of authorized repairers. Such a distribution network or repair network is based on a package of similar arrangements between the manufacturer and individual distributors or workshops (Vošta, 2015 pp.40.). For competition law purposes, these agreements are called vertical agreements because the producer and distributor or repairer operate at different levels of the production or distribution chain. Article 81 of the Treaty on European Community applies to agreements which may affect trade between Member States and which prevent, restrict or distort competitiveness. The first condition for the application of art. 81 is that the contracts concerned are capable of having a



significant effect on trade between Member States. This is usually the case when the network extends over the entire territory of Member State (Treaty 2006). When this first condition is met, art. 81 par. 1 prohibits agreements that significantly restrict or distort competition. This may be the case when vertical agreements not only determine the price and quantity for a specific sale and purchase transaction, but also contain restrictions imposed on the seller or the buyer. Article 81 paragraph 3 considers this prohibition not to be applicable to agreements, the benefits of which, such as efficiency improvements, are so great that they outweigh the anti-competitive effects. Such agreements are defined as being exempt under Art. 81 par. 3. Agreements may be exempt if consumers receive a fair share of the benefits resulting from these improvements. Whether the vertical agreement actually restricts competition and whether in such case the benefits outweigh the anti-competitive effects often depends on the market structure. As a rule, this requires an individual assessment. However, the Commission may also grant a waiver by way of regulation for entire categories of agreements. Such regulations are commonly referred to as sector exemption regulations. In the automotive sector, the 1995 Sectoral Exemption Regulation was replaced by Commission GVO Regulation 1400/2002 of 31 July 2002 on the application of Article 81 par. 3 of the Treaty on the European Community to the category of vertical agreements and concerted practices in the automotive sector. The Regulation, which entered into force on October 1, 2002, introduced a number of significant changes to the exemption of agreements on the distribution of new motor vehicles and spare parts. It also introduces important changes regarding the exemption of agreements for the provision of repair and maintenance services by authorized workshops and independent repairers or other independent entities, such as companies providing roadside assistance services, spare parts distributors and companies offering training for body and paint repairs workers. At the beginning of the considerations, it should be noted that before the introduction of sectoral exclusions in the automotive market in the European Union in 2002, there were probably restrictions in the field of competition. They concerned both the sale of new vehicles as well as spare parts or repair services. As the analysis of the available literature suggests, one of the basic premises for the introduction of sectoral exemptions on the automotive market were activities of consumer organizations aimed at limiting the decision-making and impact of manufacturers of given vehicle brands on the structure of this market (Creutzig 2003 pp.22). At the end of the 1990s, the resistance of consumer organizations grew, which felt that a protective umbrella over car manufacturers is detrimental to consumers, and in particular, causes the prices of cars, parts and services to be overstated. In defense of free competition in the European automotive industry, one side of the dispute was consumer organizations and the automotive independent sector, and on the other hand – car companies. Dealers shared opinions – stronger and more active support the modification of regulations, others were afraid of changes and the loss of a protective umbrella of corporations. The European Commission, under the pressure of consumer organizations, came to the following conclusions that it is becoming increasingly difficult to talk about free competition on the European automotive market, as 75% of the market is occupied by the six largest automotive companies, which in addition are consolidating their forces more and more. In addition, the need to maintain a close relationship between car sales and after-sales service was not recognized. Also, the approval of authorized stations from the producer of a given brand has not been approved, because in the opinion of the commission this led to inhibiting their development to a greater extent than the producer predicted. However, the huge dominance of certain producers and importers reflects adversely on customers and their rights, which is associated with too high prices for the sale of new cars. In 2000-2002, a great media and lobbying battle took place, in which the Directorate-General for Competitiveness of the European Commission under the leadership of Italian Mario Monti became the supporters of the liberalization of this sector of the market. The effect of these activities was the introduction of Regulation 1400/2002 (GVO) which was a block exemption

regulation concerning the automotive sector. These included arrangements for the distribution of new motor vehicles and spare parts as well as distribution agreements governing the provision of repair and maintenance services by authorized repairers. It also dealt with the issue of access to technical information of independent entities, directly or indirectly involved in the repair or review of motor vehicles, such as independent workshops, as well as the issue of access to spare parts. The aim of introducing sectoral exclusions was, therefore, limiting the decision-making and influence of the producer of a given brand both on the structure of the market for the production and sale of vehicles as well as services in the field of vehicle repair and sale of spare parts. The regulation considered the general policy according to which the block exemption decisions should only include restrictive agreements only to certain threshold market share levels – in this case, the threshold is 30%, although for the quantitative selective distribution of new motor vehicles it amounts to 40%. In addition, the Regulation only covers those agreements in which the general conditions are met. An important part of this Regulation focused on practices and activities that severely restricted competition from the common market and which were detrimental to consumers. For this purpose, and in line with the Commission's general approach to block exemption regulations, a list of very serious limitations, often referred to as 'black clauses' or 'basic restrictions', is provided explaining what is not normally allowed. In addition to the list of basic restrictions, the Regulation placed specific conditions for some vertical restraints, in particular non-compete obligations. Where the specific conditions mentioned are not met, the vertical restraints concerned shall be withdrawn from the block exemption. The most important changes related to the introduction of sectoral exemptions on the European Union automotive market include:

- Prohibition of combining selective distribution and exclusive distribution. Manufacturers, when assigning their distributors, had to decide whether to create a selective or exclusive distribution system.
- Strengthening the competitiveness within a single brand between dealers in EU Member States and improving market integration, in particular by maintaining distribution agreements that limit passive sales, maintain distribution agreements in selective distribution systems that limit active sales, and maintain clauses (commonly referred to as "clauses") Prohibiting dealers operating in selective distribution systems, establishing new points of sale in other places in the Common Market.
- Eradication of the sell and service obligation by the same entity. These regulations allowed dealers to commission service and repair services to authorized repairers who belong to the repair network of a given brand, and which therefore meet the manufacturer's quality standards.
- Facilitating multi-branding by eliminating restrictions on the sale of one brand of motor vehicles by one dealer. However, car suppliers may impose the obligation to display motor vehicles of different brands in different places in the same salon.
- Maintaining the "availability clause" by not freezing agreements restricting the dealer's ability to sell cars with different specifications, but being equivalent models that fall within the scope of the dealer's agreement.
- Strengthening the independence of dealers from producers, both by stimulating multi-brand sales and by strengthening minimum standards for contract securing.
- Allowing manufacturers to set criteria for the selection of authorized repairers, as long as they do not prevent the use of any of the rights enshrined in the Regulation.
- Ensure that if the supplier of new motor vehicles sets qualitative criteria for authorized garages belonging to his network, then all entities that meet these criteria can join the network.
- Facilitating the access of authorized repairers to spare parts, competitive in relation to the parts sold by the vehicle manufacturer.

- Preserving and strengthening the competitive position of independent workshops through access to technical information.
- Unification and categorization of spare parts (four categories) used for vehicle repairs, both warranty and post-warranty (Lewicki 2016).

At this stage, it is worth noting that the Regulation did not apply, *inter alia*, to vehicles which are not motor vehicles, motor vehicles that are not new, to bank loans financing the purchase of a vehicle by the ultimate user, or to products that are not spare parts within the meaning of the definition contained in this EU Regulation. The Regulation was, however, applicable to vertical agreements in the motor vehicle sector at all levels of trade – from the first stage of delivery of a new motor vehicle, through its manufacturer, to final resale to final consumers and from the first delivery of spare parts, through their manufacturer, to the provision of repair and maintenance services final consumers. At this stage of considerations, after almost sixteen years from the introduction of these legal regulations in European Union member states, the economic benefits of these changes should be summarized. The most important are:

- The prices of the original parts dropped. According to available DEKRA reports, the prices of these parts dropped by around 15% on average (it should be remembered that the margin on original parts is estimated at 30% to 50%).
- The availability of cheaper parts of comparable quality or non-original parts, which are used both during the repairs of authorized and unauthorized workshops, increased.
- The prices for automotive services declined by about 10%. DEKRA report, especially in the group of intermediate services, carried out on unauthorized services, equipped with measuring instruments and equipment with an average technological level. It is noteworthy, however, that the prices of services performed with the use of specialist equipment increased by about 20%. (The opportunity to buy a new car in a very rich equipment has increased.
- There has been a the phenomenon of guarantee extension granted by producers for new cars acquired in authorized showrooms.
- There has been a slight decrease in vehicle prices due to competitiveness between dealers of individual brands.
- The consumer has gained the opportunity to achieve a significant price discount on the selected vehicle model and brand.
- The costs of vehicle maintenance and collision repairs decreased due to access to new categories of spare parts.
- Insurance companies have introduced new insurance variants depending on the type of spare parts used during repairs.
- Vehicle dealers have introduced new forms of financing the purchase of vehicles.
- Many dealers decided to authorize another brand (the so-called multi-branding) both in the field of car sales and service – the vision of multi-dealer and diversification of services led to increased profits.
- Dealers applied much more extensive forms of marketing when selling vehicles (details depended on the type of distribution chosen by the car company for a given area). The dealers used the Internet unlimitedly, treated as so-called passive sales, accepting orders for cars from the end customer from any country and ordering in the group requested by this customer picking the car. In the competition they are not limited by the minimum price imposed by the group, they used price discounts for sale to the end customer.
- Dealers have benefited from the right to repair cars of any brands – either as authorized services of particular brands, or as independent workshops – without any restrictions from

the parent company. This solution has led to an increased income from body and paint repairs.

- Repair workshops have exercised the right to purchase original parts and parts of comparable quality from other sources and to use them for the repair of authorized brand vehicles (unless it is a warranty repair or free service repair). This regulation has broadened the possibility of competing with the cheaper sector of independent workshops to date.
- Repair workshops have gained access to specialist technical information.
- There was an increase in employment in the automotive sector.

Based on the above considerations, the authors state that either for private users, vehicle dealers, as well as for independent spare parts distributors or unauthorized workshops, the introduction of the mentioned EU regulations not only brought measurable economic benefits but also increased competitiveness on the market.

### 3. CONCLUSION

Summing up, as indicated by the observations of market reality and the analysis of available literature from experience gained by the Commission in the context of the Regulation 1400/2002, the increase in the prices of individual repairs is only partially reflected in the increased reliability of today's cars and longer intervals between subsequent service repairs. These trends result from technical development and from the increasing complexity and reliability of car components purchased by vehicle manufacturers from suppliers of original spare parts. These suppliers sell their products as spare parts on the market of after-sales goods and services, both through the network of authorized vehicle manufacturers' workshops and independent channels, thus constituting an important competitive force on the market of after-sales goods and services for motor vehicles. The average costs of motor vehicle repair and maintenance services borne by consumers in the European Union is a very high percentage of total consumer spending on motor vehicles. In the opinion of the authors of these considerations, these economic premises should become a sufficient postulate supporting the extension of the discussed legal regulations after 2023.

### LITERATURE:

1. Andersen J. (2001). *Study of the impact of possible future legislative scenarios for motor vehicle distribution on all parties concerned*, Moto Conference, Hamburg, pp.23.
2. *Automotive Industry Report in the European Union* (2017). Dekra Berlin, pp. 45-67.
3. *Automotive New Europe* (2002.,2003,2004,2005,2006 und 2007): Global Market Data Book. Crain Communications Inc. Detroit und Oberpfaffenhofen 2002, 2003, 2004, 2005, 2006 und 2008.
4. *Bozon L und das ICDP Team* (2009), *New Vehicle Supply in a Fast Falling Market ICDP Resarch Report 01/2009 Solihull ( UK),2009*. pp.34-35
5. *Commission Regulation (EC) No 1475/95 of 28 June 1995 on the application of Article 81 par. 3 of the Treaty on the European Community to certain categories of agreements on the distribution and servicing of motor vehicles* (OJ L 145, of 29/06/1995, p. 25).
6. *Commission Regulation (EC) No. 1400/2002 of the Commission of July 31, 2002 on the application of art. 81 par. 3 of the Treaty to vertical groups of agreements and concerted practices in the motor vehicle sector* (Official Journal EC No. 203/30).
7. *Commission Regulation (EC) No 461/2010 of 27 May 2010 on the application of Article 101 par. 3 of the Treaty on the Functioning of the European Union to the category of vertical agreements and concerted practices in the motor vehicle sector*.
8. Creutzig J. (2003), *EG-Gruppenfreistellungs-Verordnung (GVO) für den Kraftfahrzeugsektor*. Wettbewerb in Recht und Praxis, Berlin.

9. *Explanatory Brochure to the Commission Regulation (EC) NO 1400/2002 OF 31 July 2002*, (2002) Distribution and Servicing of Motor Vehicles in the European Union- European Commission – Directorate General of Competition, p. 28
10. Lademann J. (2001), *Consumer preferences towards existing and potential sales and servicing alternatives in automobile distribution*, Marketing und Vertrieb, Hamburg.
11. Lewicki W. (2016), *The implications of regulation of sector exclusions in the European Union practice for the establishing Communications compensations by insurance companies and liquidation of damages communication* European Journal of Service Management vol 19.
12. Porter M.E (1990) *The Competitive Advantage of Nations*. New York 1990.
13. Porter M.E (1991) *Towards a dynamic theory of strategy*. In. *Strategic Management Journal*, Nr.12 Winter Special Issue 1991, pp. 95-117.
14. Stanford J (2010) *The geography of auto globalization and the politics of auto bailouts* Cambridge Journal of Regions, Economy and Society vol.3 pp. 45.
15. *Treaty Establishing the European Community*. Consolidated version U.C. 321E from December 29, 2006.
16. Vošta, M Kocourek, A (2015): *Automobile Industry in the European Union and its Competitiveness in the World*, ACC Journal, volume 11, number 2, pp. 40–51.

## THE IMPACT OF NEW TECHNOLOGY ADOPTATION IN BUSSINES

**Ivana Martincevic**

*University North, Croatia  
ivana.martincevic@unin.hr*

**Goran Kozina**

*University North, Croatia  
gokozina@unin.hr*

### **ABSTRACT**

*Trends in globalization change market rules on a daily basis, which faces everyday companies with sudden, unexpected and unpredictable changes, where companies need promptly and accurately to respond on market and make business decisions in order to achieve market competitiveness. It is precisely technology and its sudden and everyday development that are one of the key factors that today make the company recognizable on market and focused on achieving business goals. Nowadays technologically-motivated companies find new ways to communicate with existing and new consumers and, in order to gain competitive advantage, are embedded and ready to accept new technologies in their strategy. The main aim of this paper is to explore the impact and the importance of new technology and its adaptation and application in business.*

**Keywords:** *Business, Globalization, New Technologies*

### **1. INTRODUCTION**

Today, businesses can hardly defend themselves from the influence of global competition that is becoming more intense. In order to achieve market expansion and market growth, locally and globally, companies need to find new ways how to operate on the market to ensure a continuous process of sustaining economic growth and to ensure their own development and growth in a competitive environment. Being competitive in the market and achieving positive business results is one of the main tasks of the company today if they want to survive on the market. Trends are changing, technology is increasingly progressing in all segments, so companies have new ways to increase the volume of their business to become competitive and to survive on the market. The business environment in which different organizations are operating today with the dynamics of change is characterized by the growing influence of new technological solutions that require rapid adaptation in accordance with new technological and development - communication trends. New technologies imply the usage of social media applications that are supported by various social media tools and technologies. With development of Web 2.0, social media has opened new opportunities for business activities and by achieving the set goals to increase the efficiency and efficiency of the business while ensuring competitiveness. This points to the fact that it is almost impossible for organizations to successfully operate without the application of new technologies such as social media tools and technologies. With the help of today's technology, the companies that applies the Internet platform for day-to-day business can choose small groups or even individual consumers, personalize the offer in view of their special needs and desires, and advertise such offer via direct communication. Likewise, their consumers may ask questions and give their opinion. The Internet and other electronic channels provide additional benefits such as cost reduction and increased speed and efficiency

### **2. ADOPTATION OF NEW TECHNOLOGY IN BUSSINES**

Trends in globalization change market rules on a daily basis, which faces everyday companies with sudden, unexpected and unpredictable changes, where companies need promptly and

accurately to respond on market and make business decisions in order to achieve market competitiveness. It is precisely technology and its sudden and everyday development that are one of the key factors that today make the company recognizable on market and focused on achieving business goals. Digitization enables businesses to build and maintain relationships with a significantly larger number of consumers in a more efficient manner by collecting and analyzing increasingly complex consumer behavior information, while digitalization enables consumers effectively information access about products and services. By properly formatting and establishing an appropriate communication and sales channel, the company can achieve a competitive advantage. For example, through the possibility of lower costs compared to competitors, better market coverage, better quality services and more, company can increase satisfaction of consumers and increase number of loyal consumers, which can affect to business success and its financial result. Being more and more widespread with the adaptation and application of new technology and usage of Internet and social networks as one of them, companies must adapt sales methods in line with new technological requirements and development of communication trends. Therefore, we can say that Internet is today the fastest growing communication and sales channel. Nowadays, internet communication is focuses on targeted audiences through specific sales channels such as new social media tools and technologies (email, blog, social networking, and so on). Technologically-motivated companies find new ways to communicate with existing and new consumers and, in order to gain competitive advantage, are embedded and ready to accept new technologies in their strategy. Technology and its sudden and everyday development is one of the key factors that today make the company recognizable and focused on achieving business goals. The digital world has changed communication within the organization, between organizations and their public and enables two-way communication as before (Caywood, 2013). The Internet, as a media and channel of communication, and the sales channel, is an important tool of communication with consumers precisely because of its interactivity, giving it the advantage before traditional mass media, and enables companies to develop long-term relationships, ie long-term partnerships with consumers, while its interactivity facilitates promotion and product distribution. The digital revolution, the digitalization we know today, the way that it is involved in everyday business, has proven to have changed the company's daily operations and is necessary for the normal functioning of the company and gaining market advantage. (Hoffman et al., 2011; Gordon et al., 2013; Bharadway et al., 2013; Mithas et al., 2013). The Internet has changed the way we communicate, how we operate and do business. The internet is valuable tool for sharing information, it speeds up the globalization development and internet connectivity creates new opportunities on market. Many researches prove that the use of internet has a positive impact on economic growth of various countries of the world. ( Hoon and Choi 2005., Meijers and Version 2010., Meah 2012., Salahuddin and Alam 2012., Rahman et al., 2013.) Digital revolution has changed today's business from the ground up (Hoffman et al., 2011; Eshet, 2012; Gordon et al., 2013; Bharadway et al., 2013; Mithas et al., 2013). Businesses do not need a lot of physical space, they can be virtual and they can be anywhere and do business without physical contact (Zuber and Mandić, 2013). One of the most advanced tools related to the application of information technology in today's development – communication business trends are social networks that are increasingly used in business. The business environment in which various organizations are operating today with the dynamics of change is characterized by the growing influence of new technological solutions that require rapid adaptation in accordance with new technological and development - communication trends. This points to the fact that it is almost impossible for organizations to work successfully without the application of new technologies, which with achieved goals are reflecting on its efficiency and efficiency while ensuring competitiveness. Nowadays new technology and social media as one tool of new technology is unavoidable and key factor that exist and it is used on daily based, whether on

private on companies level of usage. This platform of new technology has numerous of tools and its benefits are spreading on global level. For this reason it is necessary to understand the determinantes of acceptance of technology in the business of a company, ie the models of accepting information technology. Significant, and through research literature author's Olivera and Martins list of prominent models and theories of technology acceptance in the company are the technology acceptance model TAM (Davis 1986, Davis 1989, Davis et al. 1989), theory of planned behavior TPB) (Ajzen 1985, Ajzen 1991), unified theory of acceptance and use of technology (Venkatesh et al., 2003), theory of spreading innovation (Rogers 1995), and TOE framework, framework of technology, organization, and environment (Tornatzky and Fleischer, 1990). DOI and TOE models are at company level while TAM, TPB and UTAUT models are on an individual level. For this reason, in order to understand certain technological acceptance in the company, it is important to review the following theories: TAM, DOI and TOE. Social media tools and its technology are still in the initial phase of customization to use in business, but in some cases begins to affect the company and their organization business and hierarchy by creating networks of people, information and data, encouraging collaboration between departments and individuals, aimed at achieving business goals. Acceptance of new technology is something that management of company should incorporate into business. For that reason nowadays some companies have create "enterprise social software". "Enterprise social software" is typically used to enhance social networks, both within the enterprise and across key members of the enterprise's supply and distribution chains. Implementers view social networks as an important method for enhancing communication, coordination and collaboration for business purposes.<sup>1</sup>

### **3. SOCIAL MEDIA TOOLS AND TECHNOLOGY**

Today, businesses can't function without modern technology, so technology today is an inevitable tool that provides companies competitive edge on the market. For this reason, we can argue that companies increase their productivity and efficiency by applying the latest technology. The Internet and various of internet products made it easier for companies to enter new markets and to improve productivity. New technology imply the usage of social media applications that are supported allowing customers and companies to interact by creating, sharing, or exchanging information (Kaplan and Haenlein 2010). Social media nowadays gives a lot of new opportunities and different values to companies such as enhanced brand popularity (de Vries, Gensler &c Leeflang 2012), facilitating word-of-mouth communication (Chen et al. 2011b), increasing sales (Agnihotri et al. 2012), sharing information in a business context (Lu & Hsiao 2010) and generating social support for consumers (Ali 2011; Ballantine & Stephenson 2011).

*Table following on the next page*

---

<sup>1</sup> <https://www.gartner.com/it-glossary/enterprise-social-software> (06.11.2018.)



*Table 1: Definition of social media*

<b>Author</b>	<b>Term</b>	<b>Definition</b>
Zolkepli & Kamarulzaman (2015:190)	Social media	A group of internet-based applications that are built on the ideological and technological foundations of Web 2.0.
Carr et al. (2014: 1)	Social media	An array of platforms that allow people to interact, create, share, and/or exchange information and ideas in virtual communities and networks
Daj (2013: 16)	Social media	The term commonly given to websites, online tools, and other interactive communication technologies which allow users to interact with each other in some way, either by sharing information, opinions, knowledge, or interest
Strokes (2009: 350)	Social media	The media that is published, created, and shared by individuals on the internet, such as blogs, images, video and others.

*Adapted from: Kriangsak Chanthinok, Mahasarakham University, Thailand Phaprukbaramee Ussahawanitichakit, Mahasarakham University, Thailand Prathanporn Jhundra-indra, Mahasarakham University, Thailand: Proceedings of the Academy of Marketing Studies: Social media marketing strategy and marketing outcomes: a conceptual framework, 2015.*

To analyze and to research area of social media we must know that it would not function without existence of “Web 2.0”. The term “Web 2.0” was defined by Tom O'Reilly (2004) to refer to the type of web site where people can retrieve, share, write, and store data as desired. Web 2.0 technology basics includes basic Web technologies for publishing static web pages in the first phase of the World Wide Web (www) (for example, HTML and server side programming languages) and additional tools and technologies to create a dynamic Web environment to facilitate interaction with user and to created collaboration (eg, Adobe Flash, RSS and AJAX). In recent years the significance of the concept has been blurred by the proliferation of various web technology terminologies (Ngai et al., 2015).

Ngai et al. (2015) lists the following social media tools and technology:

- sites for sharing content (eng. media sharing sites, for example. Youtube, Instagram), allows users to transfer, organize and share multimedia content
- The blog / microblogging (eg Twitter) allows users to publish their texts and information on the web
- Web sites for social bookmarking (eng. Social bookmarking sites, npr. Pinterest), allows customers to use a common label for the purpose of recording and categorizing web content that are considered interesting
- Virtual / online communities (eg Lonely Planet, Yahoo Answers) allow users to share certain information and interests through interactive tools on the website
- Social networking sites (eg Facebook, LinkedIn, Google Plus +) make it easier and easier for individuals to build social relationships between friends and acquaintances
- virtual worlds (eg. Secon Life, Active World) provide environments that are simulated on computer web sites where people can live in a virtual world.

As said above there is a lot of social media tools and technology nowadays. One of social media tool and new technology is Social Network. Social network is the term for the form of human interaction where new people are introduced to existing contacts through social contacts or business contacts.

Social networks can be defined as web services that allow individuals to create public (all users have access) or limited (only certain users have access to) a personal profile in the system, create a list of contacts, browse and search their own list of acquaintances and other content. The most popular social networks according to number of users are Facebook, Twitter, Instagram, LinkedIn, YouTube. Social network is free to use, and earns from advertising. Users of social networks create their own small world, a society of friends that link common interests. Social networks have recently been used by Croatian advertisers who carefully created their advertising campaigns to promote their products and services to a targeted audience. The trend of using more and more social networks is more intense nowadays, so we can argue that the impact of digitization is visible in this area as well, and that companies have also recognized the importance and benefits of using social media. To use social networks, it is essential to develop a well-designed strategy and one of the steps of this strategy is the coordinated use of all major social networks. The usage of social networks in the business world is unstoppable and growing daily and new ways and opportunities to improve business are found on daily basis. Technology development and social networking tools are finding are very quickly new ways how to be applied in modern business company. All the opportunities that social networks provide and bring in relationships with individuals and societies, in the same way affect the company and their business. Companies that recognize usage of it earlier, will be in great market advantage, as opposed to those that are or are afraid to apply social networking opportunities to business, or simply not ready to invest in new technology.

#### **4. PREVIOUS RESEARCH AND LITERATURE REVIEW**

The area of social media has been elaborated and described through numerous of scientific researches that broadly handle different social media themes. There are numerous researches that deal with social media tools and technology and how nowadays such tool affects on companies business. With internet advances and with the emergence of Web 2.0. connection with individuals and with companies has expanded on internet and gained a lot of advantages for companies business. Based on recent research, it can be argued that existence social media is a research topic done by many authors who have acknowledged that social media has benefits for business. Information technology (IT) is universally regarded as an essential tool in enhancing the competitiveness of the economy of a country. How much the technology is important and unavoidable testify the numerous of articles that deal and investigate this area.. The adaptation of information technology and how its system will be embraced in organization remains the high priority research issue. Many companies have seen that acceptance of new technology have many benefits for improving its business performance. To understand such complexed area many authors explore the importance of adaptation of new technology in business. Venkatesh et al. (2000) research user acceptance of information technology in the workplace using technology acceptance model (TAM). From 2000. up till now a lot of changes are visible on the progress of adaptation of new technology and benefits of it. Oliveira et al. (2011.) gave literature review of information technology adoption models at firm level to understand the determinants of IT adoption. Liang (2007.) research the role of top management in mediating the effect of institutional pressures on IT assimilation. Nagai et al. (2015.) explains and research how social media applications are supported by various social media tools and technologies and are applied in diverse business areas. Charoensukmongkol et al. (2017.) research the implication of social media usage in CRM and business performance satisfaction. The research was conducted on 217 owners of the small shops at major marketplaces in Thailand. The results from partial least square regression analysis showed that the entrepreneurs who used social media intensively for CRM tended to report higher satisfaction with their business performance. Survey that was carried out by the author Hajli (2014.) proves the advances on the internet and the development of social media have facilitated the

interconnectivity of consumers. Maecker et al. (2016.) explore the role of interactions through corporate social media channels, such as Facebook brand pages, in customer relationship management and the results indicate that social media interactions indeed ease the upselling efforts and reduce the risk of churn. In the Republic of Croatia an interesting survey was conducted by Kovač et al (2016.) that explores the significance and the role of social networks in retailing business and they show which set of promotional activities retail business use and how they use social networks as promotional media. Grbavac and Grbavac (2014) also explore social networks as a promotional tool and media where they see social networks as a socially responsible and extremely ecological because neither paper nor plastic is used, and there is no waste that pollutes the environment in process of promotion. The scope of the promotion, sale and use of the Web site and the general usage of Internet as a media are explored in the territory of Croatia by several authors (Bosilj Vukšić and Pejić Bach, 1999, pp. 804-816). On the sample of 400 largest revenue-generating companies and websites of banks, where they compare the content of the Web site and analyze the basic functions: customer communication, marketing activities, sales on the Web and customer support. Chanthinok et al (2015) are investigating the relationship of social media marketing strategy and marketing outcomes. Many paper researches have been done in the area that connects social media and marketing, showing that it has an effect on business performance by cost reduction in marketing and customer service operations ((Barker et al., 2013; Evans, 2010). Due to research in 2015. by Beqiri it is proven and are given result that show importance of social media for business purposes and a positive trend of usage of social media tools and techniques in period of 2010 – 2015.. Not only that technology is something nowadays as “must have” research in 2014 by Zamora-Torres takes out that technology plus innovation are main sources of gaining competitiveness on market.

## 5. CONCLUSION

Due to globalization and digitalization in the contemporary global market, the use of social media and social networks as one of social media tools is one of the ways of recognizing and ranking companies, but also of achieving competitive advantage. The advantage of communicating through social networks is reflected through the ability to get product feedback in a very short time, or almost instantaneously, if it is online. Given that this information can be obtained in the short term, companies are able to react quickly. Due to development of internet technology companies can gain competitive advantage in the global marketplace, where technological and communication innovations move business boundaries on a daily basis, and it can not simply be created or maintained.

## LITERATURE:

1. Agnihotri, R., Kothandaraman, P., Kashyap, R. & Singh, R. (2012) Bringing ‘social’ into sales: the impact of salespeople’s social media use on service behaviors and value creation. *Journal of Personal Selling & Sales Management*, 32, 3, pp. 333-348.
2. Ali, H. (2011) Exchanging value within individuals’ networks: social support implications for health marketers. *Journal of Marketing Management*, 27, 3/4, pp. 316-335.
3. Ballantine, RW & Stephenson, R.J. (2011) Help me, I’m fat! Social support in online weight loss networks. *Journal of Consumer Behaviour*, 10, 6, pp. 332-337.
4. Barker, M. S., Donald L. B., Nicholas F. B. & Krista E. N. (2013). *Social media marketing : A strategic approach*. Mason, OH : South-Western, Cengage Learning
5. Beqiri, G., *Marketers and social media marketing*, Proceedings of the Multidisciplinary Academic Conference;2015, p91-98
6. Bharadwaj, A., El Sawy, O. A., Pavlou, P. A., & Venkatraman, N. (2013). Digital business strategy: toward a next generation of insights. *MIS Quarterly*, 37(2), 471-482.

7. Bosilj Vukšić, V., Pejić-Bach, M. : WWW mjesta poduzeća i banaka u Hrvatskoj, *Ekonomski pregled*, 50 (1999), No. 7-8; 804-816
8. Caywood, C. L. (2013). of Integrated Marketing Communications, *The Handbook of Communication and Corporate Reputation*, 49, 94.
9. Chen, Y., Fay, S. & Wang, Q. (2011b) The role of marketing in social media: how online consumer reviews evolve. *Journal of Interactive Marketing*, 25, 2, pp. 85-94.
10. Choi, C. and Yi, M.H. (2004). The effect of the internet on inflation: Panel data evidence. *Journal of Policy Modeling*, 27(7), 885–889.
11. De Vries, L., Gensler, S., Leeflang, E.S.H. (2012) Popularity of brand posts on brand fan pages: an investigation of the effects of social media marketing. *Journal of Interactive Marketing*, 26, 2, pp. 83-91.
12. Evans, D. (2010). *Social media marketing : The next generation of business engagement*. Sybex : Wiley Publishing.
13. Gordon, E., Baldwin-Philippi, J., & Balestra, M. (2013). Why we engage: How theories of human behavior contribute to our understanding of civic engagement in a digital era. Berkman Center Research Publication, (21)
14. Grbavac, J., Grbavac, V.: Pojava društvenih mreža kao globalnog komunikacijskog fenomena, *Media, culture and public relations*, 5, 2014, 2, 206-219
15. Hoffman, D. L., & Novak, T. P. (2011). Marketing communication in a digital era, *Marketing Management*, 20(3), 36-43.
16. Kaplan, Andreas M., and Michael Haenlein. 2010. Users of the world, unite! The challenges and opportunities of social media. *Business Horizons* 53(1): 59–68.
17. Kriangsak Chanthinok, Mahasarakham University, Thailand Phaprukbaramee Ussahawanitichakit, Mahasarakham University, Thailand Prathanporn Jhundra-indra, Mahasarakham University, Thailand: *Proceedings of the Academy of Marketing Studies: Social media marketing strategy and marketing outcomes: a conceptual framework*, 2015.
18. Lu, H.-P & Hsiao, K.-L. (2010) The influence of extro/introversion on the intention to pay for social networking sites. *Information & Management*, 47, 3, pp. 150-157.
19. Meah, M. (2012). The impact of internet on economic growth in Bangladesh. <https://dspace.cuny.edu/bitstream/handle/11049/24131/2012SpSs13.pdf?sequence=1>
20. Mithas, S., Tafti, A., & Mitchell, W. (2013). How a firm's competitive environment and digital strategic posture influence digital business strategy. *MIS Quarterly*, 37(2), 511-536.
21. Ngai, E.W.T., Moon, Ka-lenug, K., Lam, S.S., Chin, E.S.K., Tao S., S.C., (2015.) Social media models, technologies, and applications, *Industrial Management & Data Systems*, Vol.115 No.5, 2015., pp.769-802
22. Olivera, T., Martins, M.F., (2011) Literature Review of Information Technology Adoption Models at Firm Level, *The Electronic Journal Information Systems Evaluation*, Vol.14, Issue 1, pp 110-121
23. Rahman, A. Nayeem, M. Haroon, A. Tooheen, R. (2013). ICT impact on socio-economic conditions of rural Bangladesh. *Journal of World Economic Research*. 1-8. Retrieved from <http://www.sciencepublishinggroup.com/j/jwer>
24. Salahuddin, M. (2013). Internet usage and economic growth in Australia: An ARDL bounds testing approach. University of Southern Queensland, Australia Khorshed Alam University of Southern Queensland, Australia. Retrieved from [https://editorialexpress.com/cgi-bin/conference/download.cgi?db\\_name=ESAMAC E2014&paper\\_id=263](https://editorialexpress.com/cgi-bin/conference/download.cgi?db_name=ESAMAC E2014&paper_id=263)  
[www.mckinsey.com/insights/high\\_tech...internet/the\\_great\\_transformer](http://www.mckinsey.com/insights/high_tech...internet/the_great_transformer)
25. Zamora-Torres, A.I., Countries' competitiveness on innovation and technology, *Global Journal of Business Research*, Vol. 8, No. 5, 2014, pp. 73-83



كلية العلوم القانونية والاقتصادية والاجتماعية - سلا  
Fakultet pravnih, ekonomskih i društvenih nauka  
**Faculté des sciences juridiques  
économiques et sociales-salé**